



PIC16C55X(A)

EPROM-Based 8-Bit CMOS Microcontroller

Devices included in this data sheet:

Referred to collectively as PIC16C55X(A).

- PIC16C554 PIC16C554A
- PIC16C556A
- PIC16C558 PIC16C558A

High Performance RISC CPU:

- Only 35 instructions to learn
- All single-cycle instructions (200 ns), except for program branches which are two-cycle
- Operating speed:
 - DC - 20 MHz clock input
 - DC - 200 ns instruction cycle

| Device | Program Memory | Data Memory |
|------------|----------------|-------------|
| PIC16C554 | 512 | 80 |
| PIC16C554A | 512 | 80 |
| PIC16C556A | 1K | 80 |
| PIC16C558 | 2K | 128 |
| PIC16C558A | 2K | 128 |

- Interrupt capability
- 16 special function hardware registers
- 8-level deep hardware stack
- Direct, Indirect and Relative addressing modes

Peripheral Features:

- 13 I/O pins with individual direction control
- High current sink/source for direct LED drive
- Timer0: 8-bit timer/counter with 8-bit programmable prescaler

Special Microcontroller Features:

- Power-on Reset (POR)
- Power-up Timer (PWRT) and Oscillator Start-up Timer (OST)
- Watchdog Timer (WDT) with its own on-chip RC oscillator for reliable operation

Pin Diagram

PDIP, SOIC, Windowed Cerdip

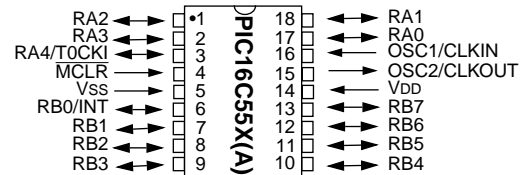

SSOP

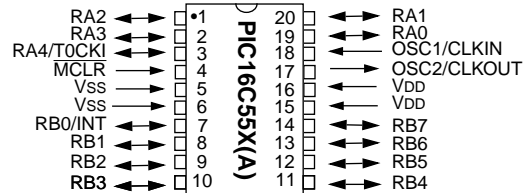

Special Microcontroller Features (cont'd)

- Programmable code protection
- Power saving SLEEP mode
- Selectable oscillator options
- Serial in-circuit programming (via two pins)
- Four user programmable ID locations

CMOS Technology:

- Low-power, high-speed CMOS EPROM technology
- Fully static design
- Wide operating voltage range
 - 2.5V to 5.5V PIC16C55X
 - 3.0 to 5.5V PIC16C55XA
- Commercial, industrial and extended temperature range
- Low power consumption
 - < 2.0 mA @ 5.0V, 4.0 MHz
 - 15 μ A typical @ 3.0V, 32 kHz
 - < 1.0 μ A typical standby current @ 3.0V

PIC16C55X(A)

Device Differences

| Device | Voltage Range | Oscillator | Process Technology (Microns) |
|------------|---------------|------------|------------------------------|
| PIC16C554 | 2.5 - 5.5 | See Note 1 | 0.9 |
| PIC16C554A | 3.0 - 5.5 | See Note 1 | 0.7 |
| PIC16C556A | 3.0 - 5.5 | See Note 1 | 0.7 |
| PIC16C558 | 2.5 - 5.5 | See Note 1 | 0.9 |
| PIC16C558A | 3.0 - 5.5 | See Note 1 | 0.7 |

Note 1: If you change from this device to another device, please verify oscillator characteristics in your application.

Table of Contents

| | | |
|---|------------------------------------|----|
| 1.0 | General Description..... | 5 |
| 2.0 | PIC16C55X(A) Device Varieties..... | 7 |
| 3.0 | Architectural Overview | 9 |
| 4.0 | Memory Organization | 13 |
| 5.0 | I/O Ports | 23 |
| 6.0 | Timer0 Module | 29 |
| 7.0 | Special Features of the CPU | 35 |
| 8.0 | Instruction Set Summary | 51 |
| 9.0 | Development Support..... | 63 |
| 10.0 | Electrical Specifications..... | 67 |
| 11.0 | Packaging Information..... | 79 |
| Appendix A: | Enhancements..... | 87 |
| Appendix B: | Compatibility | 87 |
| INDEX..... | | 89 |
| PIC16C55X(A) Product Identification System..... | | 95 |

To Our Valued Customers

We constantly strive to improve the quality of all our products and documentation. To this end, we recently converted to a new publishing software package which we believe will enhance our entire documentation process and product. As in any conversion process, information may have accidentally been altered or deleted. We have spent an exceptional amount of time to ensure that these documents are correct. However, we realize that we may have missed a few things. If you find any information that is missing or appears in error from the previous version of this data sheet (PIC16C55X(A) Data Sheet, Literature Number DS40143B), please use the reader response form in the back of this data sheet to inform us. We appreciate your assistance in making this a better document.

PIC16C55X(A)

NOTES:

1.0 GENERAL DESCRIPTION

The PIC16C55X(A) are 18 and 20-Pin EPROM-based members of the versatile PIC16CXX family of low-cost, high-performance, CMOS, fully-static, 8-bit microcontrollers.

All PICmicro™ microcontrollers employ an advanced RISC architecture. The PIC16C55X(A) have enhanced core features, eight-level deep stack, and multiple internal and external interrupt sources. The separate instruction and data buses of the Harvard architecture allow a 14-bit wide instruction word with the separate 8-bit wide data. The two-stage instruction pipeline allows all instructions to execute in a single-cycle, except for program branches (which require two cycles). A total of 35 instructions (reduced instruction set) are available. Additionally, a large register set gives some of the architectural innovations used to achieve a very high performance.

PIC16C55X(A) microcontrollers typically achieve a 2:1 code compression and a 4:1 speed improvement over other 8-bit microcontrollers in their class.

The PIC16C554(A) and PIC16C556A have 80 bytes of RAM. The PIC16C558(A) has 128 bytes of RAM. Each device has 13 I/O pins and an 8-bit timer/counter with an 8-bit programmable prescaler.

PIC16C55X(A) devices have special features to reduce external components, thus reducing cost, enhancing system reliability and reducing power consumption. There are four oscillator options, of which the single pin RC oscillator provides a low-cost solution, the LP oscillator minimizes power consumption, XT is a standard crystal, and the HS is for High Speed crystals. The SLEEP (power-down) mode offers power saving. The user can wake up the chip from SLEEP through several external and internal interrupts and reset.

A highly reliable Watchdog Timer with its own on-chip RC oscillator provides protection against software lock-up.

A UV-erasable CERDIP-packaged version is ideal for code development while the cost-effective One-Time Programmable (OTP) version is suitable for production in any volume.

Table 1-1 shows the features of the PIC16C55X(A) mid-range microcontroller families.

A simplified block diagram of the PIC16C55X(A) is shown in Figure 3-1.

The PIC16C55X(A) series fit perfectly in applications ranging from motor control to low-power remote sensors. The EPROM technology makes customization of application programs (detection levels, pulse generation, timers, etc.) extremely fast and convenient. The small footprint packages make this microcontroller series perfect for all applications with space limitations. Low-cost, low-power, high-performance, ease of use and I/O flexibility make the PIC16C55X(A) very versatile.

1.1 Family and Upward Compatibility

Those users familiar with the PIC16C5X family of microcontrollers will realize that this is an enhanced version of the PIC16C5X architecture. Please refer to Appendix A for a detailed list of enhancements. Code written for PIC16C5X can be easily ported to PIC16C55X(A) family of devices (Appendix B).

The PIC16C55X(A) family fills the niche for users wanting to migrate up from the PIC16C5X family and not needing various peripheral features of other members of the PIC16XX mid-range microcontroller family.

1.2 Development Support

The PIC16C55X(A) family is supported by a full-featured macro assembler, a software simulator, an in-circuit emulator, a low-cost development programmer and a full-featured programmer. A "C" compiler and fuzzy logic support tools are also available.

PIC16C55X(A)

TABLE 1-1: PIC16C55X(A) FAMILY OF DEVICES

| | | PIC16C554 | PIC16C554A | PIC16C556A | PIC16C558 | PIC16C558A |
|---|--------------------------------------|-------------------------------------|-------------------------------------|-------------------------------------|-------------------------------------|-------------------------------------|
| Clock | Maximum Frequency of Operation (MHz) | 20 | 20 | 20 | 20 | 20 |
| Memory | EPROM Program Memory (x14 words) | 512 | 512 | 1K | 2K | 2K |
| | Data Memory (bytes) | 80 | 80 | 80 | 128 | 128 |
| Peripherals | Timer Module(s) | TMR0 | TMR0 | TMR0 | TMR0 | TMR0 |
| Features | Interrupt Sources | 3 | 3 | 3 | 3 | 3 |
| | I/O Pins | 13 | 13 | 13 | 13 | 13 |
| | Voltage Range (Volts) | 2.5-5.5 | 3.0-5.5 | 3.0-5.5 | 2.5-5.5 | 3.0-5.5 |
| | Brown-out Reset | — | — | — | — | — |
| | Packages | 18-pin DIP, SOIC; 20-pin SSOP | 18-pin DIP, SOIC; 20-pin SSOP | 18-pin DIP, SOIC; 20-pin SSOP | 18-pin DIP, SOIC; 20-pin SSOP | 18-pin DIP, SOIC; 20-pin SSOP |
| All PICmicro™ Family devices have Power-on Reset, selectable Watchdog Timer, selectable code protect and high I/O current capability. All PIC16C55X(A) Family devices use serial programming with clock pin RB6 and data pin RB7. | | | | | | |

2.0 PIC16C55X(A) DEVICE VARIETIES

A variety of frequency ranges and packaging options are available. Depending on application and production requirements the proper device option can be selected using the information in the PIC16C55X(A) Product Identification System section at the end of this data sheet. When placing orders, please use this page of the data sheet to specify the correct part number.

2.1 UV Erasable Devices

The UV erasable version, offered in CERDIP package is optimal for prototype development and pilot programs. This version can be erased and reprogrammed to any of the oscillator modes.

Microchip's PICSTART[®] and PROMATE[®] programmers both support programming of the PIC16C55X(A).

2.2 One-Time-Programmable (OTP) Devices

The availability of OTP devices is especially useful for customers who need the flexibility for frequent code updates and small volume applications. In addition to the program memory, the configuration bits must also be programmed.

2.3 Quick-Turnaround-Production (QTP) Devices

Microchip offers a QTP Programming Service for factory production orders. This service is made available for users who choose not to program a medium to high quantity of units and whose code patterns have stabilized. The devices are identical to the OTP devices but with all EPROM locations and configuration options already programmed by the factory. Certain code and prototype verification procedures apply before production shipments are available. Please contact your Microchip Technology sales office for more details.

2.4 Serialized Quick-Turnaround-Production (SQTPSM) Devices

Microchip offers a unique programming service where a few user-defined locations in each device are programmed with different serial numbers. The serial numbers may be random, pseudo-random or sequential.

Serial programming allows each device to have a unique number which can serve as an entry-code, password or ID number.

PIC16C55X(A)

NOTES:

3.0 ARCHITECTURAL OVERVIEW

The high performance of the PIC16C55X(A) family can be attributed to a number of architectural features commonly found in RISC microprocessors. To begin with, the PIC16C55X(A) uses a Harvard architecture, in which, program and data are accessed from separate memories using separate busses. This improves bandwidth over traditional von Neumann architecture where program and data are fetched from the same memory. Separating program and data memory further allows instructions to be sized differently than 8-bit wide data words. Instruction opcodes are 14-bits wide making it possible to have all single word instructions. A 14-bit wide program memory access bus fetches a 14-bit instruction in a single cycle. A two-stage pipeline overlaps fetch and execution of instructions. Consequently, all instructions (35) execute in a single-cycle (200 ns @ 20 MHz) except for program branches.

The PIC16C554(A) addresses 512 x 14 on-chip program memory. The PIC16C556A addresses 1K x 14 program memory. The PIC16C558(A) addresses 2K x 14 program memory. All program memory is internal.

The PIC16C55X(A) can directly or indirectly address its register files or data memory. All special function registers including the program counter are mapped into the data memory. The PIC16C55X(A) have an orthogonal (symmetrical) instruction set that makes it possible to carry out any operation on any register using any addressing mode. This symmetrical nature and lack of 'special optimal situations' make programming with the PIC16C55X(A) simple yet efficient. In addition, the learning curve is reduced significantly.

The PIC16C55X(A) devices contain an 8-bit ALU and working register. The ALU is a general purpose arithmetic unit. It performs arithmetic and Boolean functions between data in the working register and any register file.

The ALU is 8-bits wide and capable of addition, subtraction, shift and logical operations. Unless otherwise mentioned, arithmetic operations are two's complement in nature. In two-operand instructions, typically one operand is the working register (W register). The other operand is a file register or an immediate constant. In single operand instructions, the operand is either the W register or a file register.

The W register is an 8-bit working register used for ALU operations. It is not an addressable register.

Depending on the instruction executed, the ALU may affect the values of the Carry (C), Digit Carry (DC), and Zero (Z) bits in the STATUS register. The C and DC bits operate as a Borrow and Digit Borrow out bit, respectively, in subtraction. See the SUBLW and SUBWF instructions for examples.

A simplified block diagram is shown in Figure 3-1, with a description of the device pins in Table 3-1.

PIC16C55X(A)

FIGURE 3-1: BLOCK DIAGRAM

| Device | Program Memory | Data Memory (RAM) |
|------------|----------------|-------------------|
| PIC16C554 | 512 x 14 | 80 x 8 |
| PIC16C554A | 512 x 14 | 80 x 8 |
| PIC16C556A | 1K x 14 | 80 x 8 |
| PIC16C558 | 2K x 14 | 128 x 8 |
| PIC16C558A | 2K x 14 | 128 x 8 |

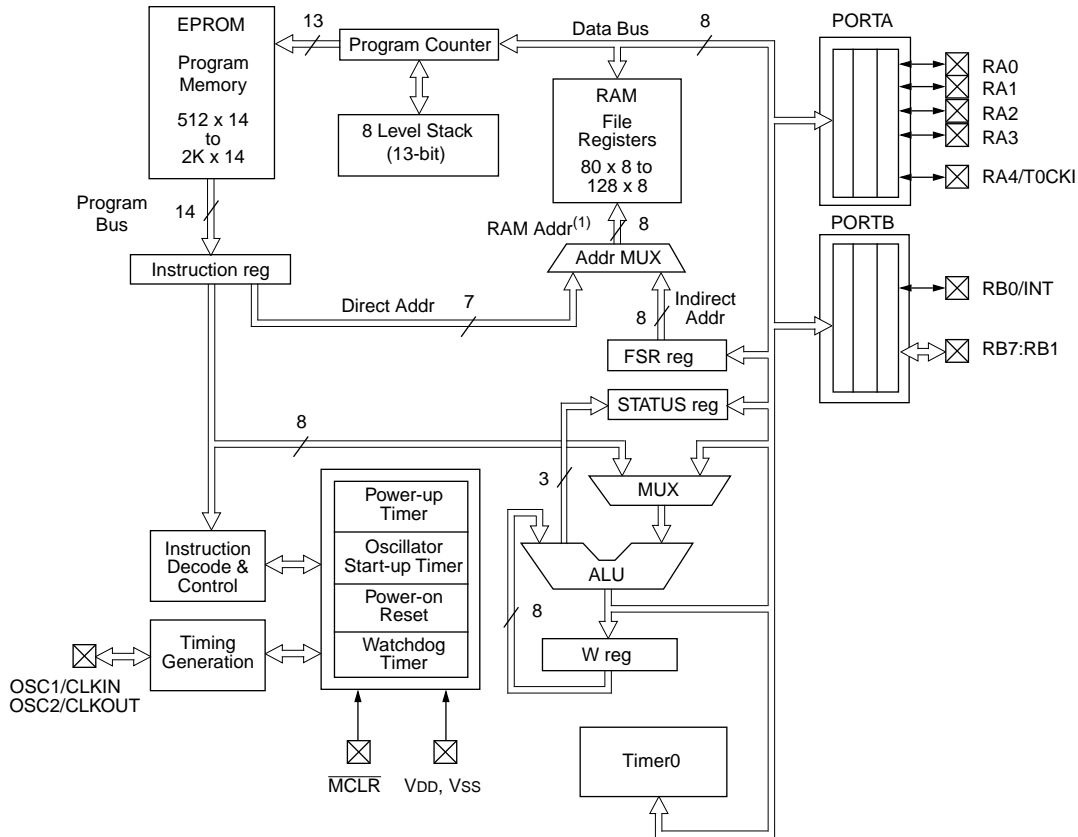

Note 1: Higher order bits are from the status register.

TABLE 3-1: PIC16C55X(A) PINOUT DESCRIPTION

| Name | DIP SOIC Pin # | SSOP Pin # | I/O/P Type | Buffer Type | Description |
|-------------|----------------|------------|------------|-----------------------|--|
| OSC1/CLKIN | 16 | 18 | I | ST/CMOS | Oscillator crystal input/external clock source input. |
| OSC2/CLKOUT | 15 | 17 | O | — | Oscillator crystal output. Connects to crystal or resonator in crystal oscillator mode. In RC mode, OSC2 pin outputs CLKOUT which has 1/4 the frequency of OSC1, and denotes the instruction cycle rate. |
| MCLR/VPP | 4 | 4 | I/P | ST | Master clear (reset) input/programming voltage input. This pin is an active low reset to the device. |
| RA0 | 17 | 19 | I/O | ST | PORTA is a bi-directional I/O port. Can be selected to be the clock input to the Timer0 timer/counter. Output is open drain type. |
| RA1 | 18 | 20 | I/O | ST | |
| RA2 | 1 | 1 | I/O | ST | |
| RA3 | 2 | 2 | I/O | ST | |
| RA4/T0CKI | 3 | 3 | I/O | ST | |
| RB0/INT | 6 | 7 | I/O | TTL/ST ⁽¹⁾ | PORTB is a bi-directional I/O port. PORTB can be software programmed for internal weak pull-up on all inputs. RB0/INT can also be selected as an external interrupt pin. Interrupt on change pin. Interrupt on change pin. Interrupt on change pin. Serial programming clock. Interrupt on change pin. Serial programming data. |
| RB1 | 7 | 8 | I/O | TTL | |
| RB2 | 8 | 9 | I/O | TTL | |
| RB3 | 9 | 10 | I/O | TTL | |
| RB4 | 10 | 11 | I/O | TTL | |
| RB5 | 11 | 12 | I/O | TTL | |
| RB6 | 12 | 13 | I/O | TTL/ST ⁽²⁾ | |
| RB7 | 13 | 14 | I/O | TTL/ST ⁽²⁾ | |
| VSS | 5 | 5,6 | P | — | Ground reference for logic and I/O pins. |
| VDD | 14 | 15,16 | P | — | Positive supply for logic and I/O pins. |

Legend: O = output I/O = input/output P = power
 — = Not used I = Input ST = Schmitt Trigger input
 TTL = TTL input

Note 1: This buffer is a Schmitt Trigger input when configured as the external interrupt.

Note 2: This buffer is a Schmitt Trigger input when used in serial programming mode.

PIC16C55X(A)

3.1 Clocking Scheme/Instruction Cycle

The clock input (OSC1/CLKIN pin) is internally divided by four to generate four non-overlapping quadrature clocks namely Q1, Q2, Q3 and Q4. Internally, the program counter (PC) is incremented every Q1, the instruction is fetched from the program memory and latched into the instruction register in Q4. The instruction is decoded and executed during the following Q1 through Q4. The clocks and instruction execution flow are shown in Figure 3-2.

3.2 Instruction Flow/Pipelining

An "Instruction Cycle" consists of four Q cycles (Q1, Q2, Q3 and Q4). The instruction fetch and execute are pipelined such that fetch takes one instruction cycle while decode and execute takes another instruction cycle. However, due to the pipelining, each instruction effectively executes in one cycle. If an instruction causes the program counter to change (e.g., GOTO) then two cycles are required to complete the instruction (Example 3-1).

A fetch cycle begins with the program counter (PC) incrementing in Q1.

In the execution cycle, the fetched instruction is latched into the "Instruction Register (IR)" in cycle Q1. This instruction is then decoded and executed during the Q2, Q3, and Q4 cycles. Data memory is read during Q2 (operand read) and written during Q4 (destination write).

FIGURE 3-2: CLOCK/INSTRUCTION CYCLE

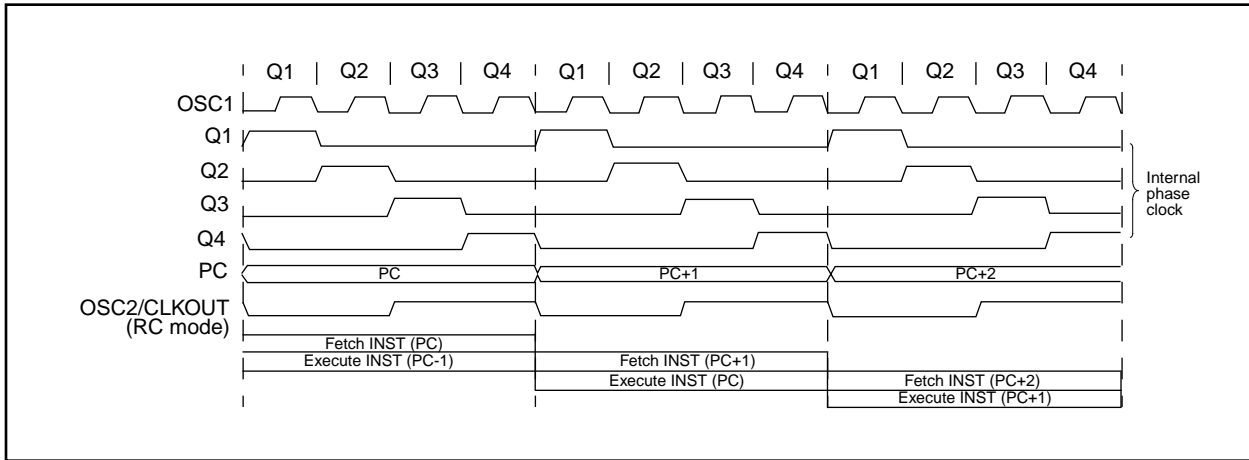

EXAMPLE 3-1: INSTRUCTION PIPELINE FLOW

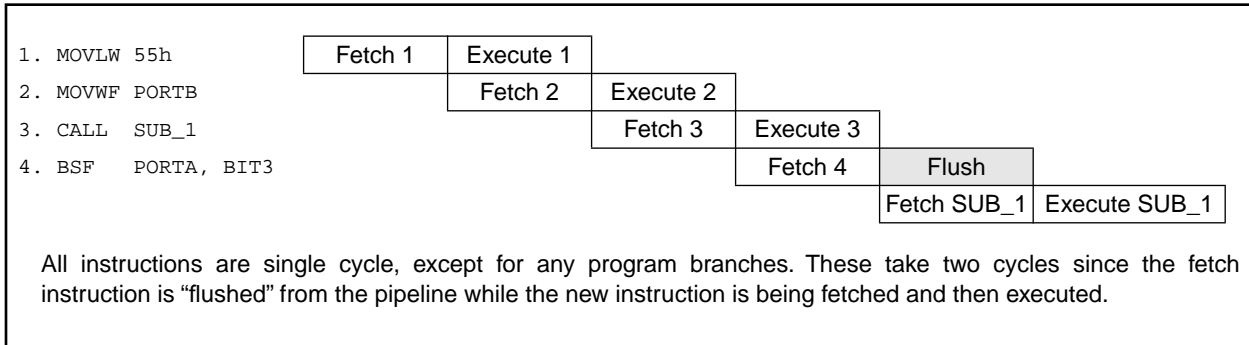

4.0 MEMORY ORGANIZATION

4.1 Program Memory Organization

The PIC16C55X(A) has a 13-bit program counter capable of addressing an 8K x 14 program memory space. Only the first 512 x 14 (0000h - 01FFh) for the PIC16C554(A), 1K x 14 (0000h - 03FFh) for the PIC16C556A and 2K x 14 (0000h - 07FFh) for the PIC16C558(A) are physically implemented. Accessing a location above these boundaries will cause a wrap-around within the first 512 x 14 space PIC16C554(A) or 1K x 14 space PIC16C556A or 2K x 14 space PIC16C558(A). The reset vector is at 0000h and the interrupt vector is at 0004h (Figure 4-1, Figure 4-2, Figure 4-3).

FIGURE 4-1: PROGRAM MEMORY MAP AND STACK FOR THE PIC16C554/PIC16C554A

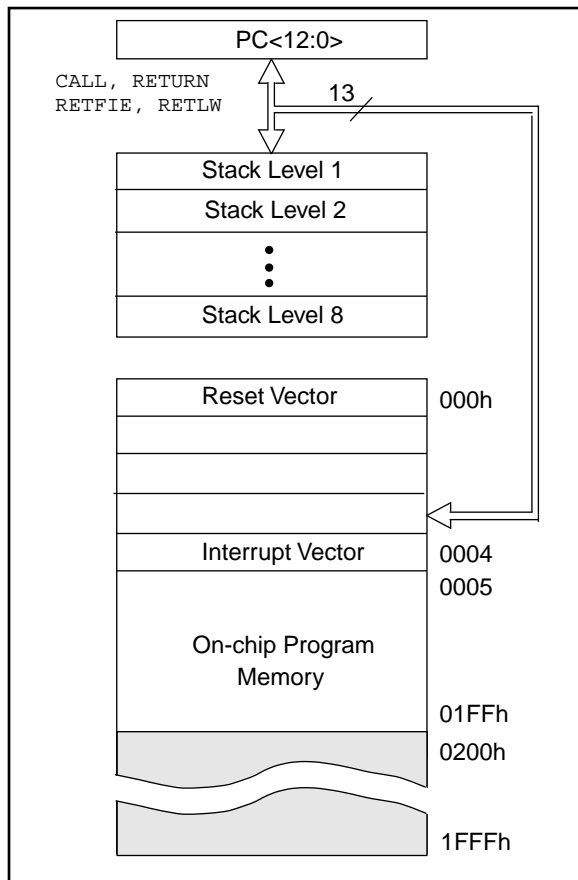

FIGURE 4-2: PROGRAM MEMORY MAP AND STACK FOR THE PIC16C556A

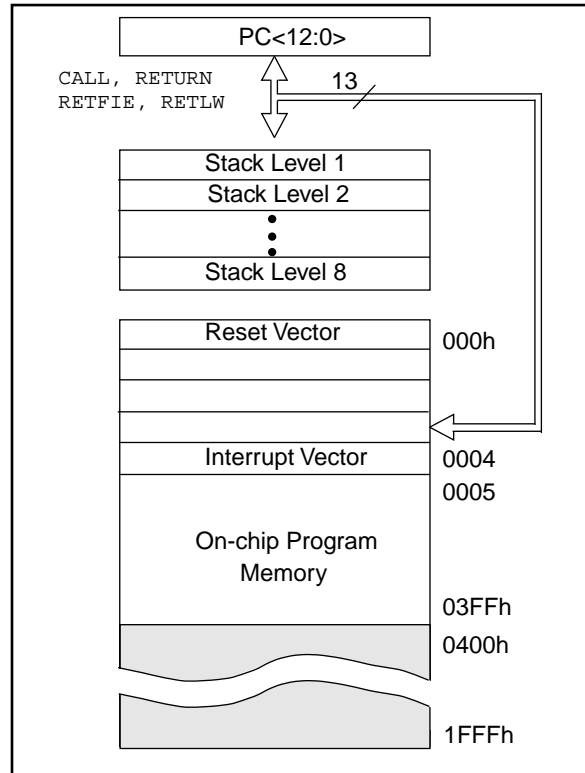
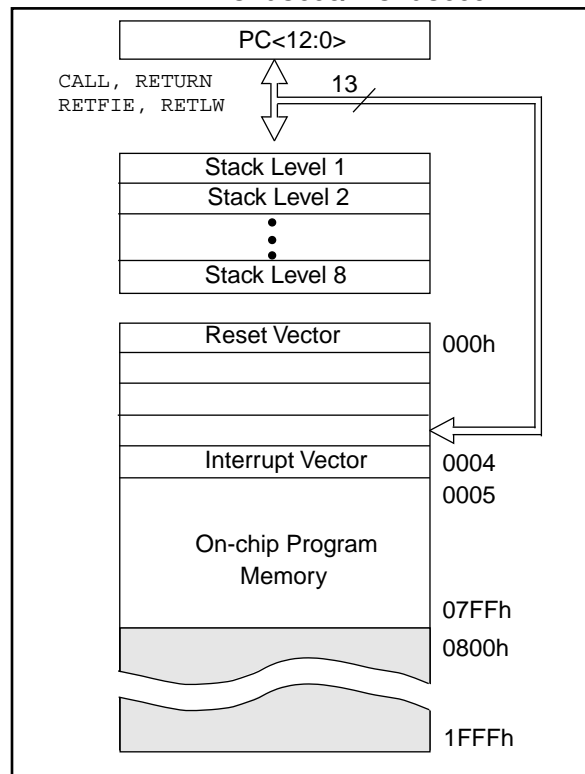

FIGURE 4-3: PROGRAM MEMORY MAP AND STACK FOR THE PIC16C558/PIC16C558A



PIC16C55X(A)

4.2 Data Memory Organization

The data memory (Figure 4-4 and Figure 4-5) is partitioned into two Banks which contain the general purpose registers and the special function registers. Bank 0 is selected when the RP0 bit is cleared. Bank 1 is selected when the RP0 bit (STATUS <5>) is set. The Special Function Registers are located in the first 32 locations of each Bank. Register locations 20-6Fh (Bank0) on the PIC16C554(A)/556A and 20-7Fh (Bank0) and A0-BFh (Bank1) on the PIC16C558(A) are general purpose registers implemented as static RAM. Some special purpose registers are mapped in Bank 1.

4.2.1 GENERAL PURPOSE REGISTER FILE

The register file is organized as 80 x 8 in the PIC16C554(A)/556A and 128 x 8 in the PIC16C558(A). Each is accessed either directly or indirectly through the File Select Register, FSR (Section 4.4).

FIGURE 4-4: DATA MEMORY MAP FOR THE PIC16C554(A)/556A

| File Address | | | File Address |
|--------------|--------------------------|---------------------|--------------|
| 00h | INDF ⁽¹⁾ | INDF ⁽¹⁾ | 80h |
| 01h | TMR0 | OPTION | 81h |
| 02h | PCL | PCL | 82h |
| 03h | STATUS | STATUS | 83h |
| 04h | FSR | FSR | 84h |
| 05h | PORTA | TRISA | 85h |
| 06h | PORTB | TRISB | 86h |
| 07h | | | 87h |
| 08h | | | 88h |
| 09h | | | 89h |
| 0Ah | PCLATH | PCLATH | 8Ah |
| 0Bh | INTCON | INTCON | 8Bh |
| 0Ch | | | 8Ch |
| 0Dh | | | 8Dh |
| 0Eh | | PCON | 8Eh |
| 0Fh | | | 8Fh |
| 10h | | | 90h |
| 11h | | | 91h |
| 12h | | | 92h |
| 13h | | | 93h |
| 14h | | | 94h |
| 15h | | | 95h |
| 16h | | | 96h |
| 17h | | | 97h |
| 18h | | | 98h |
| 19h | | | 99h |
| 1Ah | | | 9Ah |
| 1Bh | | | 9Bh |
| 1Ch | | | 9Ch |
| 1Dh | | | 9Dh |
| 1Eh | | | 9Eh |
| 1Fh | | | 9Fh |
| 20h | | | A0h |
| | General Purpose Register | | |
| 6Fh | | | |
| 70h | | | |
| | | | |
| | | | |
| 7Fh | | | FFh |
| | Bank 0 | Bank 1 | |

Unimplemented data memory locations, read as '0'.
 Note 1: Not a physical register.

FIGURE 4-5: DATA MEMORY MAP FOR THE PIC16C558(A)

| File Address | | | File Address |
|--------------|--------------------------|--------------------------|--------------|
| 00h | INDF ⁽¹⁾ | INDF ⁽¹⁾ | 80h |
| 01h | TMR0 | OPTION | 81h |
| 02h | PCL | PCL | 82h |
| 03h | STATUS | STATUS | 83h |
| 04h | FSR | FSR | 84h |
| 05h | PORTA | TRISA | 85h |
| 06h | PORTB | TRISB | 86h |
| 07h | | | 87h |
| 08h | | | 88h |
| 09h | | | 89h |
| 0Ah | PCLATH | PCLATH | 8Ah |
| 0Bh | INTCON | INTCON | 8Bh |
| 0Ch | | | 8Ch |
| 0Dh | | | 8Dh |
| 0Eh | | PCON | 8Eh |
| 0Fh | | | 8Fh |
| 10h | | | 90h |
| 11h | | | 91h |
| 12h | | | 92h |
| 13h | | | 93h |
| 14h | | | 94h |
| 15h | | | 95h |
| 16h | | | 96h |
| 17h | | | 97h |
| 18h | | | 98h |
| 19h | | | 99h |
| 1Ah | | | 9Ah |
| 1Bh | | | 9Bh |
| 1Ch | | | 9Ch |
| 1Dh | | | 9Dh |
| 1Eh | | | 9Eh |
| 1Fh | | | 9Fh |
| 20h | | | A0h |
| | General Purpose Register | General Purpose Register | |
| | | | BFh |
| | | | C0h |
| | | | |
| | | | |
| 7Fh | | | FFh |
| | Bank 0 | Bank 1 | |

Unimplemented data memory locations, read as '0'.
 Note 1: Not a physical register.

PIC16C55X(A)

4.2.2 SPECIAL FUNCTION REGISTERS

The special function registers are registers used by the CPU and Peripheral functions for controlling the desired operation of the device (Table 4-1). These registers are static RAM.

The special function registers can be classified into two sets (core and peripheral). The special function registers associated with the “core” functions are described in this section. Those related to the operation of the peripheral features are described in the section of that peripheral feature.

TABLE 4-1: SPECIAL REGISTERS FOR THE PIC16C55X(A)

| Address | Name | Bit 7 | Bit 6 | Bit 5 | Bit 4 | Bit 3 | Bit 2 | Bit 1 | Bit 0 | Value on POR Reset | Value on all other resets ⁽¹⁾ |
|---------------|---------------|--|--------------------|--------|--|--------|--------|--------|--------|--------------------|--|
| Bank 0 | | | | | | | | | | | |
| 00h | INDF | Addressing this location uses contents of FSR to address data memory (not a physical register) | | | | | | | | xxxx xxxx | xxxx xxxx |
| 01h | TMR0 | Timer0 Module's Register | | | | | | | | xxxx xxxx | uuuu uuuu |
| 02h | PCL | Program Counter's (PC) Least Significant Byte | | | | | | | | 0000 0000 | 0000 0000 |
| 03h | STATUS | IRP ⁽²⁾ | RP1 ⁽²⁾ | RP0 | T0 | PD | Z | DC | C | 0001 1xxx | 000q quuu |
| 04h | FSR | Indirect data memory address pointer | | | | | | | | xxxx xxxx | uuuu uuuu |
| 05h | PORTA | — | — | — | RA4 | RA3 | RA2 | RA1 | RA0 | ---x xxxx | ---u uuuu |
| 06h | PORTB | RB7 | RB6 | RB5 | RB4 | RB3 | RB2 | RB1 | RB0 | xxxx xxxx | uuuu uuuu |
| 07h | Unimplemented | | | | | | | | | — | — |
| 08h | Unimplemented | | | | | | | | | — | — |
| 09h | Unimplemented | | | | | | | | | — | — |
| 0Ah | PCLATH | — | — | — | Write buffer for upper 5 bits of program counter | | | | | ---0 0000 | ---0 0000 |
| 0Bh | INTCON | GIE | (3) | TOIE | INTE | RBIE | TOIF | INTF | RBIF | 0000 000x | 0000 000x |
| 0Ch | Unimplemented | | | | | | | | | — | — |
| 0Dh-1Eh | Unimplemented | | | | | | | | | — | — |
| 1Fh | Unimplemented | | | | | | | | | — | — |
| Bank 1 | | | | | | | | | | | |
| 80h | INDF | Addressing this location uses contents of FSR to address data memory (not a physical register) | | | | | | | | xxxx xxxx | xxxx xxxx |
| 81h | OPTION | RBPU | INTEDG | T0CS | T0SE | PSA | PS2 | PS1 | PS0 | 1111 1111 | 1111 1111 |
| 82h | PCL | Program Counter's (PC) Least Significant Byte | | | | | | | | 0000 0000 | 0000 0000 |
| 83h | STATUS | — | — | RP0 | T0 | PD | Z | DC | C | 0001 1xxx | 000q quuu |
| 84h | FSR | Indirect data memory address pointer | | | | | | | | xxxx xxxx | uuuu uuuu |
| 85h | TRISA | — | — | — | TRISA4 | TRISA3 | TRISA2 | TRISA1 | TRISA0 | ---1 1111 | ---1 1111 |
| 86h | TRISB | TRISB7 | TRISB6 | TRISB5 | TRISB4 | TRISB3 | TRISB2 | TRISB1 | TRISB0 | 1111 1111 | 1111 1111 |
| 87h | Unimplemented | | | | | | | | | — | — |
| 88h | Unimplemented | | | | | | | | | — | — |
| 89h | Unimplemented | | | | | | | | | — | — |
| 8Ah | PCLATH | — | — | — | Write buffer for upper 5 bits of program counter | | | | | ---0 0000 | ---0 0000 |
| 8Bh | INTCON | GIE | (3) | TOIE | INTE | RBIE | TOIF | INTF | RBIF | 0000 000x | 0000 000x |
| 8Ch | Unimplemented | | | | | | | | | — | — |
| 8Dh | Unimplemented | | | | | | | | | — | — |
| 8Eh | PCON | — | — | — | — | — | — | POR | — | ---- --0- | ---- --u- |
| 8Fh-9Eh | Unimplemented | | | | | | | | | — | — |
| 9Fh | Unimplemented | | | | | | | | | — | — |

Legend: — = Unimplemented locations read as '0', u = unchanged, x = unknown, q = value depends on condition, shaded = unimplemented

Note 1: Other (non power-up) resets include MCLR reset and Watchdog Timer reset during normal operation.

Note 2: IRP & RPI bits are reserved, always maintain these bits clear.

Note 3: Bit 6 of INTCON register is reserved for future use. Always maintain this bit as clear.

4.2.2.1 STATUS REGISTER

The STATUS register, shown in Figure 4-6, contains the arithmetic status of the ALU, the RESET status and the bank select bits for data memory.

The STATUS register can be the destination for any instruction, like any other register. If the STATUS register is the destination for an instruction that affects the Z, DC or C bits, then the write to these three bits is disabled. These bits are set or cleared according to the device logic. Furthermore, the \overline{TO} and \overline{PD} bits are not writable. Therefore, the result of an instruction with the STATUS register as the destination may be different than intended.

For example, `CLRF STATUS` will clear the upper-three bits and set the Z bit. This leaves the status register as `000uu1uu` (where `u` = unchanged).

It is recommended, therefore, that only `BCF`, `BSF`, `SWAPF` and `MOVWF` instructions be used to alter the STATUS register because these instructions do not affect any status bits. For other instructions, not affecting any status bits, see the "Instruction Set Summary".

Note 1: The IRP and RP1 bits (STATUS<7:6>) are not used by the PIC16C55X(A) and should be programmed as '0'. Use of these bits as general purpose R/W bits is NOT recommended, since this may affect upward compatibility with future products.

Note 2: The C and DC bits operate as a Borrow and Digit Borrow out bit, respectively, in subtraction. See the `SUBLW` and `SUBWF` instructions for examples.

FIGURE 4-6: STATUS REGISTER (ADDRESS 03H OR 83H)

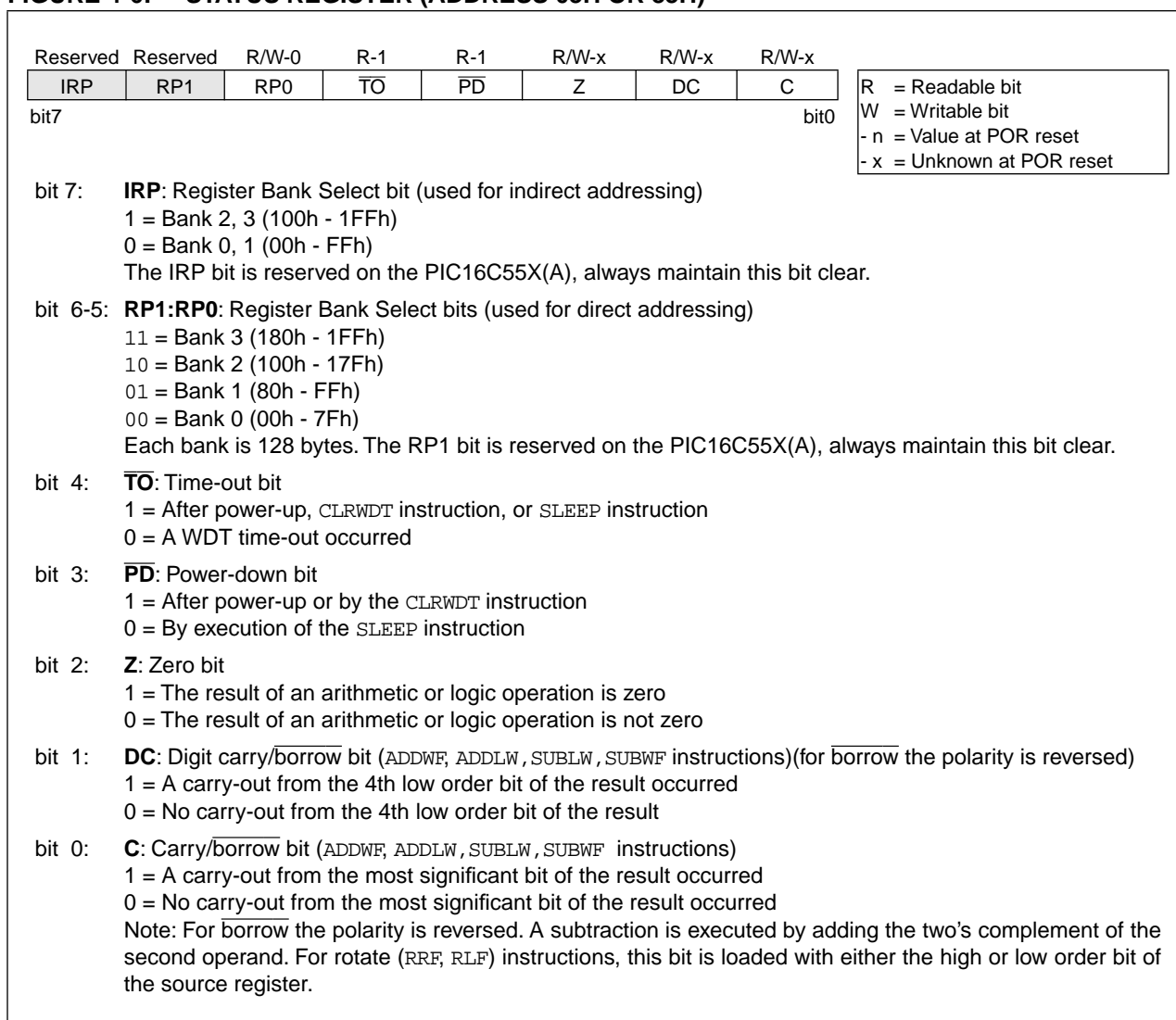

PIC16C55X(A)

4.2.2.2 OPTION REGISTER

The OPTION register is a readable and writable register which contains various control bits to configure the TMR0/WDT prescaler, the external RB0/INT interrupt, TMR0 and the weak pull-ups on PORTB.

Note: To achieve a 1:1 prescaler assignment for TMR0, assign the prescaler to the WDT (PSA = 1).

FIGURE 4-7: OPTION REGISTER (ADDRESS 81H)

| | R/W-1 | R/W-1 | R/W-1 | R/W-1 | R/W-1 | R/W-1 | R/W-1 | | |
|----------|--|-----------|-------|-------|-------|-------|-------|--|----------|
| bit7 | RBPŪ | INTEDG | T0CS | T0SE | PSA | PS2 | PS1 | PS0 bit0 | |
| | | | | | | | | R = Readable bit W = Writable bit - n = Value at POR reset | |
| bit 7: | RBPŪ: PORTB Pull-up Enable bit 1 = PORTB pull-ups are disabled 0 = PORTB pull-ups are enabled by individual port latch values | | | | | | | | |
| bit 6: | INTEDG: Interrupt Edge Select bit 1 = Interrupt on rising edge of RB0/INT pin 0 = Interrupt on falling edge of RB0/INT pin | | | | | | | | |
| bit 5: | T0CS: TMR0 Clock Source Select bit 1 = Transition on RA4/T0CKI pin 0 = Internal instruction cycle clock (CLKOUT) | | | | | | | | |
| bit 4: | T0SE: TMR0 Source Edge Select bit 1 = Increment on high-to-low transition on RA4/T0CKI pin 0 = Increment on low-to-high transition on RA4/T0CKI pin | | | | | | | | |
| bit 3: | PSA: Prescaler Assignment bit 1 = Prescaler is assigned to the WDT 0 = Prescaler is assigned to the Timer0 module | | | | | | | | |
| bit 2-0: | PS2:PS0: Prescaler Rate Select bits | | | | | | | | |
| | Bit Value | TMR0 Rate | | | | | | | WDT Rate |
| | 000 | 1 : 2 | | | | | | | 1 : 1 |
| | 001 | 1 : 4 | | | | | | | 1 : 2 |
| | 010 | 1 : 8 | | | | | | | 1 : 4 |
| | 011 | 1 : 16 | | | | | | | 1 : 8 |
| | 100 | 1 : 32 | | | | | | | 1 : 16 |
| | 101 | 1 : 64 | | | | | | | 1 : 32 |
| | 110 | 1 : 128 | | | | | | | 1 : 64 |
| | 111 | 1 : 256 | | | | | | | 1 : 128 |

4.2.2.3 INTCON REGISTER

The INTCON register is a readable and writable register which contains the various enable and flag bits for all interrupt sources.

Note: Interrupt flag bits get set when an interrupt condition occurs regardless of the state of its corresponding enable bit or the global enable bit, GIE (INTCON<7>).

FIGURE 4-8: INTCON REGISTER (ADDRESS 0BH OR 8BH)

| | R/W-0 | Reserved | R/W-0 | R/W-0 | R/W-0 | R/W-0 | R/W-0 | R/W-x | | | | |
|---|--|----------|-------|-------|-------|-------|-------|-------|------------------|------------------|--------------------------|----------------------------|
| | GIE | — | TOIE | INTE | RBIE | TOIF | INTF | RBIF | | | | |
| bit7 | | | | | | | | bit0 | | | | |
| <p>bit 7: GIE: Global Interrupt Enable bit 1 = Enables all un-masked interrupts 0 = Disables all interrupts</p> <p>bit 6: — = Reserved for future use. Always maintain this bit clear.</p> <p>bit 5: TOIE: TMR0 Overflow Interrupt Enable bit 1 = Enables the TMR0 interrupt 0 = Disables the TMR0 interrupt</p> <p>bit 4: INTE: RB0/INT External Interrupt Enable bit 1 = Enables the RB0/INT external interrupt 0 = Disables the RB0/INT external interrupt</p> <p>bit 3: RBIE: RB Port Change Interrupt Enable bit 1 = Enables the RB port change interrupt 0 = Disables the RB port change interrupt</p> <p>bit 2: TOIF: TMR0 Overflow Interrupt Flag bit 1 = TMR0 register has overflowed (must be cleared in software) 0 = TMR0 register did not overflow</p> <p>bit 1: INTF: RB0/INT External Interrupt Flag bit 1 = The RB0/INT external interrupt occurred (must be cleared in software) 0 = The RB0/INT external interrupt did not occur</p> <p>bit 0: RBIF: RB Port Change Interrupt Flag bit 1 = When at least one of the RB7:RB4 pins changed state (must be cleared in software) 0 = None of the RB7:RB4 pins have changed state</p> | <table border="1" style="border-collapse: collapse;"> <tr> <td>R = Readable bit</td> </tr> <tr> <td>W = Writable bit</td> </tr> <tr> <td>- n = Value at POR reset</td> </tr> <tr> <td>- x = Unknown at POR reset</td> </tr> </table> | | | | | | | | R = Readable bit | W = Writable bit | - n = Value at POR reset | - x = Unknown at POR reset |
| R = Readable bit | | | | | | | | | | | | |
| W = Writable bit | | | | | | | | | | | | |
| - n = Value at POR reset | | | | | | | | | | | | |
| - x = Unknown at POR reset | | | | | | | | | | | | |

PIC16C55X(A)

4.2.2.4 PCON REGISTER

The PCON register contains flag bits to differentiate between a Power-on Reset, an external MCLR reset or WDT reset. See Section 7.3 and Section 7.4 for detailed reset operation.

FIGURE 4-9: PCON REGISTER (ADDRESS 8Eh)

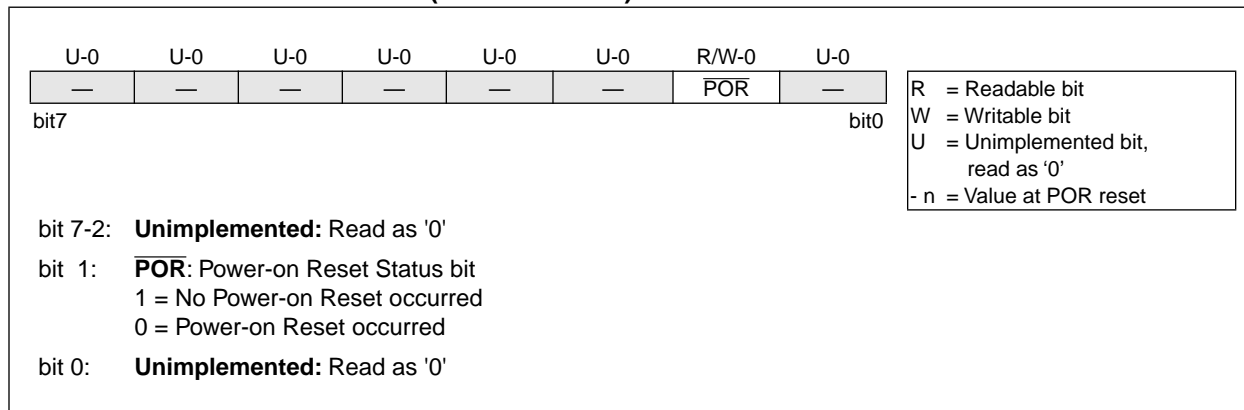

4.3 PCL and PCLATH

The program counter (PC) is 13-bits wide. The low byte comes from the PCL register, which is a readable and writable register. The high bits (PC<12:8>) are not directly readable or writable and come from PCLATH. On any reset, the PC is cleared. Figure 4-10 shows the two situations for the loading of the PC. The upper example in the figure shows how the PC is loaded on a write to PCL (PCLATH<4:0> → PCH). The lower example in the figure shows how the PC is loaded during a CALL or GOTO instruction execution (PCLATH<4:3> → PCH).

FIGURE 4-10: LOADING OF PC IN DIFFERENT SITUATIONS

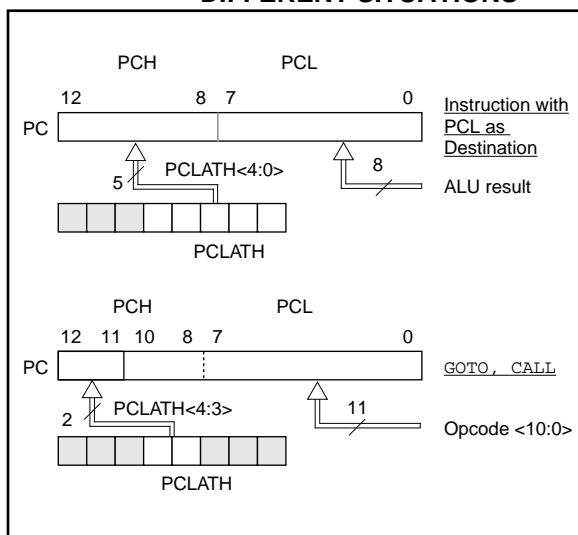

4.3.1 COMPUTED GOTO

A computed GOTO is accomplished by adding an offset to the program counter (`ADDWF PCL`). When doing a table read using a computed GOTO method, care should be exercised if the table location crosses a PCL memory boundary (each 256 byte block). Refer to the application note "Implementing a Table Read" (AN556).

4.3.2 STACK

The PIC16C55X(A) family has an 8 level deep x 13-bit wide hardware stack (Figure 4-1, Figure 4-2 and Figure 4-3). The stack space is not part of either program or data space and the stack pointer is not readable or writable. The PC is PUSHed onto the stack when a CALL instruction is executed or an interrupt causes a branch. The stack is POPed in the event of a RETURN, RETLW or a RETFIE instruction execution. PCLATH is not affected by a PUSH or POP operation.

The stack operates as a circular buffer. This means that after the stack has been PUSHed eight times, the ninth push overwrites the value that was stored from the first push. The tenth push overwrites the second push (and so on).

Note 1: There are no STATUS bits to indicate stack overflow or stack underflow conditions.

Note 2: There are no instructions mnemonics called PUSH or POP. These are actions that occur from the execution of the CALL, RETURN, RETLW and RETFIE instructions, or vectoring to an interrupt address.

PIC16C55X(A)

4.4 Indirect Addressing, INDF and FSR Registers

The INDF register is not a physical register. Addressing the INDF register will cause indirect addressing.

Indirect addressing is possible by using the INDF register. Any instruction using the INDF register actually accesses data pointed to by the file select register (FSR). Reading INDF itself indirectly will produce 00h. Writing to the INDF register indirectly results in a no-operation (although status bits may be affected). An effective 9-bit address is obtained by concatenating the 8-bit FSR register and the IRP bit (STATUS<7>), as shown in Figure 4-11. However, IRP is not used in the PIC16C55X(A).

A simple program to clear RAM locations 20h-2Fh using indirect addressing is shown in Example 4-1.

EXAMPLE 4-1: INDIRECT ADDRESSING

```

movlw 0x20 ;initialize pointer
movwf FSR ;to RAM
NEXT   clrf  INDF ;clear INDF register
       incf  FSR ;inc pointer
       btfss FSR,4 ;all done?
       goto  NEXT ;no clear next
                               ;yes continue
CONTINUE:

```

FIGURE 4-11: DIRECT/INDIRECT ADDRESSING PIC16C55X(A)

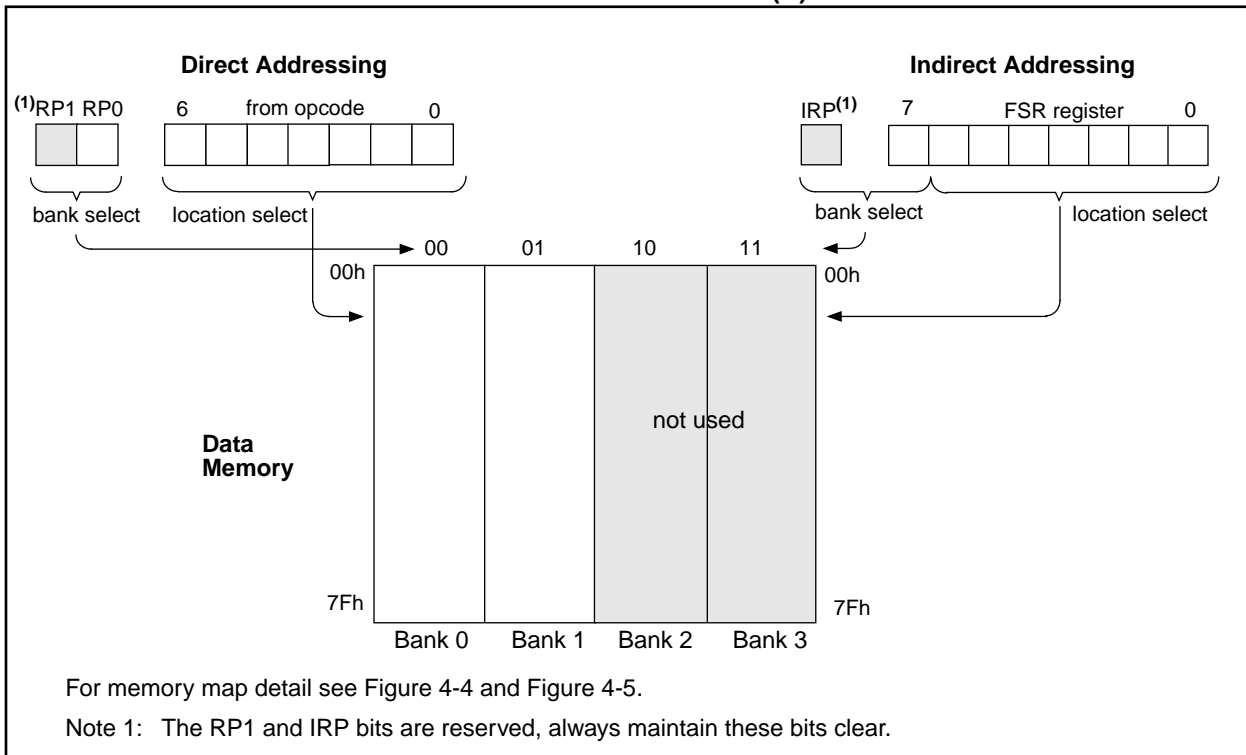

5.0 I/O PORTS

The PIC16C55X(A) have two ports, PORTA and PORTB.

5.1 PORTA and TRISA Registers

PORTA is a 5-bit wide latch. RA4 is a Schmitt Trigger input and an open drain output. Port RA4 is multiplexed with the T0CKI clock input. All other RA port pins have Schmitt Trigger input levels and full CMOS output drivers. All pins have data direction bits (TRISA registers) which can configure these pins as input or output.

A '1' in the TRISA register puts the corresponding output driver in a hi-impedance mode. A '0' in the TRISA register puts the contents of the output latch on the selected pin(s).

Reading the PORTA register reads the status of the pins, whereas writing to it will write to the port latch. All write operations are read-modify-write operations. So a write to a port implies that the port pins are first read, then this value is modified and written to the port data latch.

Note: On reset, the TRISA register is set to all inputs.

FIGURE 5-1: BLOCK DIAGRAM OF PORT PINS RA<3:0>

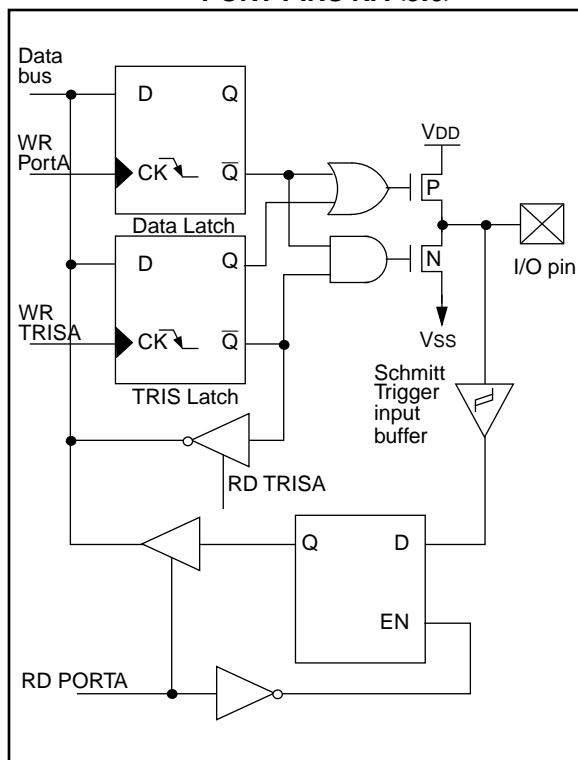
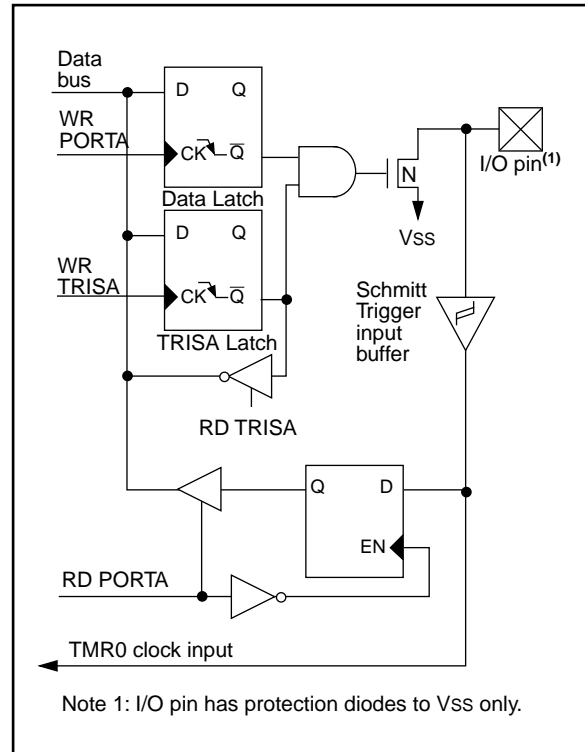

FIGURE 5-2: BLOCK DIAGRAM OF RA4 PIN



PIC16C55X(A)

TABLE 5-1: PORTA FUNCTIONS

| Name | Bit # | Buffer Type | Function |
|-----------|-------|-------------|---|
| RA0 | bit0 | ST | Input/output |
| RA1 | bit1 | ST | Input/output |
| RA2 | bit2 | ST | Input/output |
| RA3 | bit3 | ST | Input/output |
| RA4/T0CKI | bit4 | ST | Input/output or external clock input for TMR0. Output is open drain type. |

Legend: ST = Schmitt Trigger input

TABLE 5-2: SUMMARY OF REGISTERS ASSOCIATED WITH PORTA

| Address | Name | Bit 7 | Bit 6 | Bit 5 | Bit 4 | Bit 3 | Bit 2 | Bit 1 | Bit 0 | Value on POR | Value on All Other Resets |
|---------|-------|-------|-------|-------|--------|--------|--------|--------|--------|--------------|---------------------------|
| 05h | PORTA | — | — | — | RA4 | RA3 | RA2 | RA1 | RA0 | ---x xxxx | ---u uuuu |
| 85h | TRISA | — | — | — | TRISA4 | TRISA3 | TRISA2 | TRISA1 | TRISA0 | ---1 1111 | ---1 1111 |

Legend: — = Unimplemented locations, read as '0'

Note: Note: Shaded bits are not used by PORTA.

PIC16C55X(A)

TABLE 5-3: PORTB FUNCTIONS

| Name | Bit # | Buffer Type | Function |
|---------|-------|-----------------------|---|
| RB0/INT | bit0 | TTL/ST ⁽¹⁾ | Input/output or external interrupt input. Internal software programmable weak pull-up. |
| RB1 | bit1 | TTL | Input/output pin. Internal software programmable weak pull-up. |
| RB2 | bit2 | TTL | Input/output pin. Internal software programmable weak pull-up. |
| RB3 | bit3 | TTL | Input/output pin. Internal software programmable weak pull-up. |
| RB4 | bit4 | TTL | Input/output pin (with interrupt on change). Internal software programmable weak pull-up. |
| RB5 | bit5 | TTL | Input/output pin (with interrupt on change). Internal software programmable weak pull-up. |
| RB6 | bit6 | TTL/ST ⁽²⁾ | Input/output pin (with interrupt on change). Internal software programmable weak pull-up. Serial programming clock pin. |
| RB7 | bit7 | TTL/ST ⁽²⁾ | Input/output pin (with interrupt on change). Internal software programmable weak pull-up. Serial programming data pin. |

Legend: ST = Schmitt Trigger, TTL = TTL input

Note 1: This buffer is a Schmitt Trigger input when configured as the external interrupt.

Note 2: This buffer is a Schmitt Trigger input when used in serial programming mode.

TABLE 5-4: SUMMARY OF REGISTERS ASSOCIATED WITH PORTB

| Address | Name | Bit 7 | Bit 6 | Bit 5 | Bit 4 | Bit 3 | Bit 2 | Bit 1 | Bit 0 | Value on POR | Value on All Other Rests |
|---------|--------|--------|--------|--------|--------|--------|--------|--------|--------|--------------|--------------------------|
| 06h | PORTB | RB7 | RB6 | RB5 | RB4 | RB3 | RB2 | RB1 | RB0 | uuuu uuuu | xxxx xxxx |
| 86h | TRISB | TRISB7 | TRISB6 | TRISB5 | TRISB4 | TRISB3 | TRISB2 | TRISB1 | TRISB0 | 1111 1111 | 1111 1111 |
| 81h | OPTION | RBPU | INTEDG | T0CS | T0SE | PSA | PS2 | PS1 | PS0 | 1111 1111 | 1111 1111 |

Note: Shaded bits are not used by PORTB.

5.3 I/O Programming Considerations

5.3.1 BI-DIRECTIONAL I/O PORTS

Any instruction which writes, operates internally as a read followed by a write operation. The `BCF` and `BSF` instructions, for example, read the register into the CPU, execute the bit operation and write the result back to the register. Caution must be used when these instructions are applied to a port with both inputs and outputs defined. For example, a `BSF` operation on bit5 of `PORTB` will cause all eight bits of `PORTB` to be read into the CPU. Then the `BSF` operation takes place on bit5 and `PORTB` is written to the output latches. If another bit of `PORTB` is used as a bidirectional I/O pin (e.g., bit0) and it is defined as an input at this time, the input signal present on the pin itself would be read into the CPU and re-written to the data latch of this particular pin, overwriting the previous content. As long as the pin stays in the input mode, no problem occurs. However, if bit0 is switched into output mode later on, the content of the data latch may now be unknown.

Reading the port register, reads the values of the port pins. Writing to the port register writes the value to the port latch. When using read modify write instructions (ex. `BCF`, `BSF`, etc.) on a port, the value of the port pins is read, the desired operation is done to this value, and this value is then written to the port latch.

Example 5-1 shows the effect of two sequential read-modify-write instructions (ex., `BCF`, `BSF`, etc.) on an I/O port

A pin actively outputting a Low or High should not be driven from external devices at the same time in order to change the level on this pin ("wired-or", "wired-and"). The resulting high output currents may damage the chip.

EXAMPLE 5-1: READ-MODIFY-WRITE INSTRUCTIONS ON AN I/O PORT

```

; Initial PORT settings:  PORTB<7:4> Inputs
;
;                          PORTB<3:0> Outputs
; PORTB<7:6> have external pull-up and are not
; connected to other circuitry
;
;                          PORT latch  PORT pins
;                          -----  -----

BCF PORTB, 7      ; 01pp pppp  11pp pppp
BCF PORTB, 6      ; 10pp pppp  11pp pppp
BSF STATUS,RP0    ;
BCF TRISB, 7      ; 10pp pppp  11pp pppp
BCF TRISB, 6      ; 10pp pppp  10pp pppp
;
; Note that the user may have expected the pin
; values to be 00pp pppp. The 2nd BCF caused
; RB7 to be latched as the pin value (High).
    
```

5.3.2 SUCCESSIVE OPERATIONS ON I/O PORTS

The actual write to an I/O port happens at the end of an instruction cycle, whereas for reading, the data must be valid at the beginning of the instruction cycle (Figure 5-5). Therefore, care must be exercised if a write followed by a read operation is carried out on the same I/O port. The sequence of instructions should be such to allow the pin voltage to stabilize (load dependent) before the next instruction which causes that file to be read into the CPU is executed. Otherwise, the previous state of that pin may be read into the CPU rather than the new state. When in doubt, it is better to separate these instructions with an `NOP` or another instruction not accessing this I/O port.

FIGURE 5-5: SUCCESSIVE I/O OPERATION

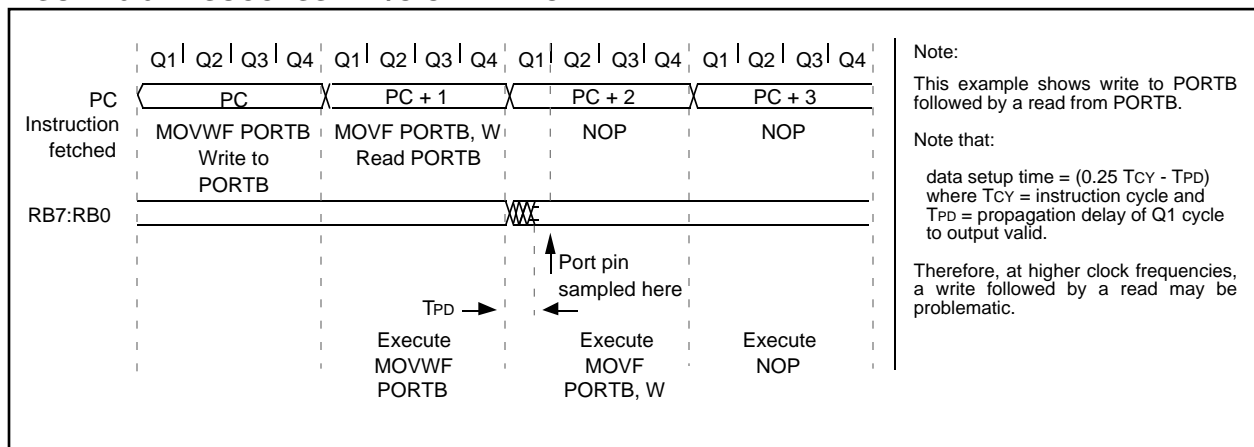

PIC16C55X(A)

NOTES:

6.0 TIMER0 MODULE

The Timer0 module timer/counter has the following features:

- 8-bit timer/counter
- Readable and writable
- 8-bit software programmable prescaler
- Internal or external clock select
- Interrupt on overflow from FFh to 00h
- Edge select for external clock

Figure 6-1 is a simplified block diagram of the Timer0 module.

Timer mode is selected by clearing the T0CS bit (OPTION<5>). In timer mode, the TMR0 will increment every instruction cycle (without prescaler). If Timer0 is written, the increment is inhibited for the following two cycles (Figure 6-2 and Figure 6-3). The user can work around this by writing an adjusted value to TMR0.

Counter mode is selected by setting the T0CS bit. In this mode Timer0 will increment either on every rising or falling edge of pin RA4/T0CKI. The incrementing edge is determined by the source edge (T0SE) control

bit (OPTION<4>). Clearing the T0SE bit selects the rising edge. Restrictions on the external clock input are discussed in detail in Section 6.2.

The prescaler is shared between the Timer0 module and the WatchdogTimer. The prescaler assignment is controlled in software by the control bit PSA (OPTION<3>). Clearing the PSA bit will assign the prescaler to Timer0. The prescaler is not readable or writable. When the prescaler is assigned to the Timer0 module, prescale value of 1:2, 1:4, ..., 1:256 are selectable. Section 6.3 details the operation of the prescaler.

6.1 TIMER0 Interrupt

Timer0 interrupt is generated when the TMR0 register timer/counter overflows from FFh to 00h. This overflow sets the TOIF bit. The interrupt can be masked by clearing the TOIE bit (INTCON<5>). The TOIF bit (INTCON<2>) must be cleared in software by the Timer0 module interrupt service routine before re-enabling this interrupt. The Timer0 interrupt cannot wake the processor from SLEEP since the timer is shut off during SLEEP. See Figure 6-4 for Timer0 interrupt timing.

FIGURE 6-1: TIMER0 BLOCK DIAGRAM

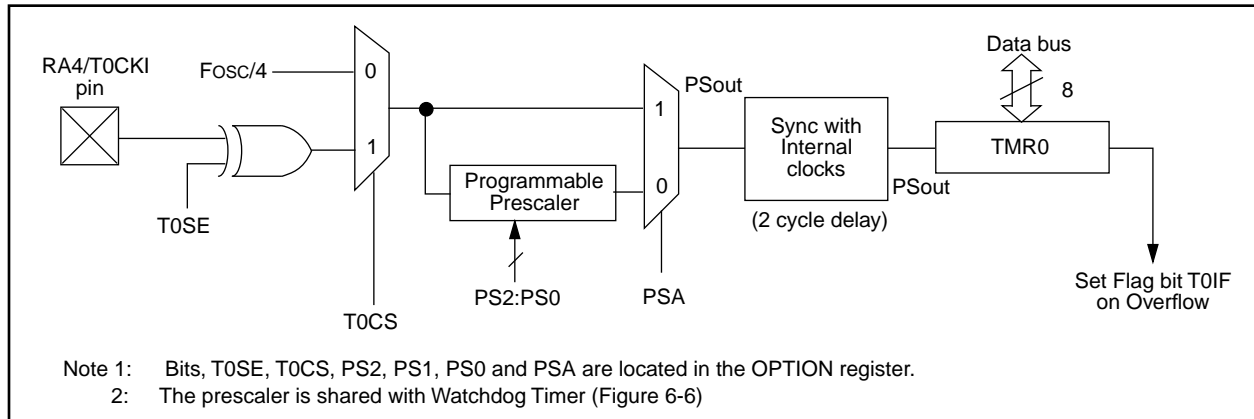
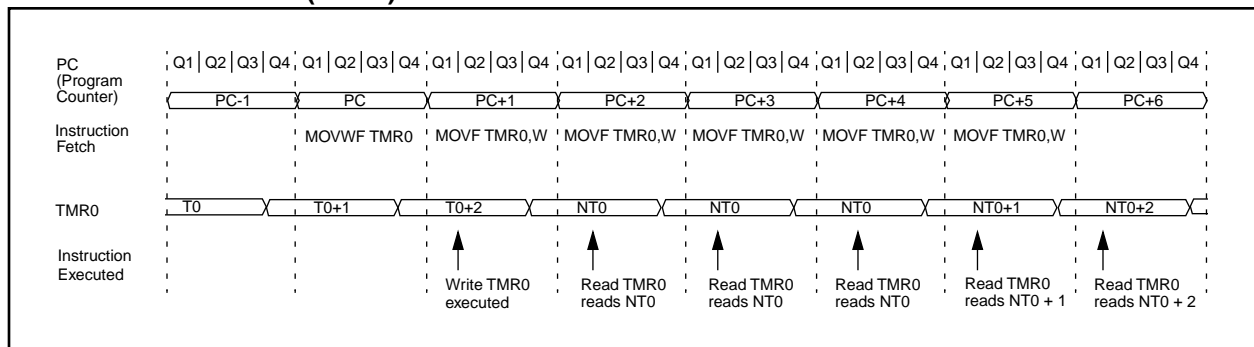

FIGURE 6-2: TIMER0 (TMR0) TIMING: INTERNAL CLOCK/NO PRESCALER



PIC16C55X(A)

FIGURE 6-3: TIMER0 TIMING: INTERNAL CLOCK/PRESCALE 1:2

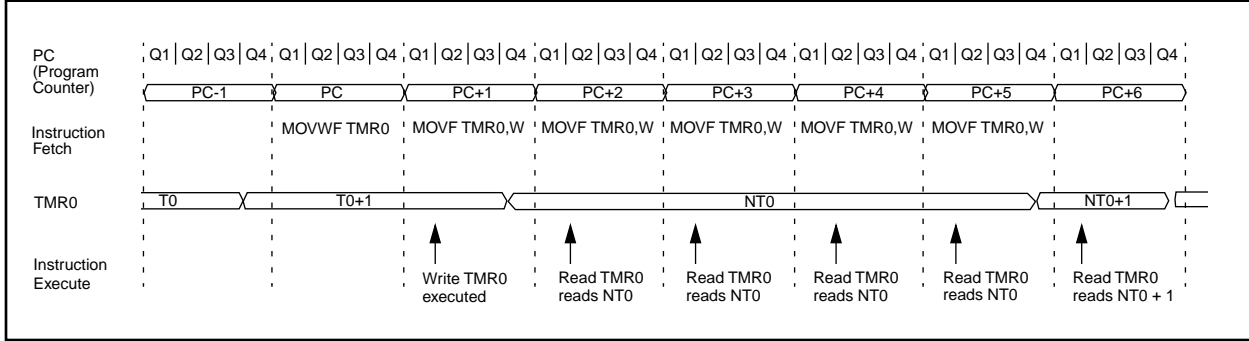
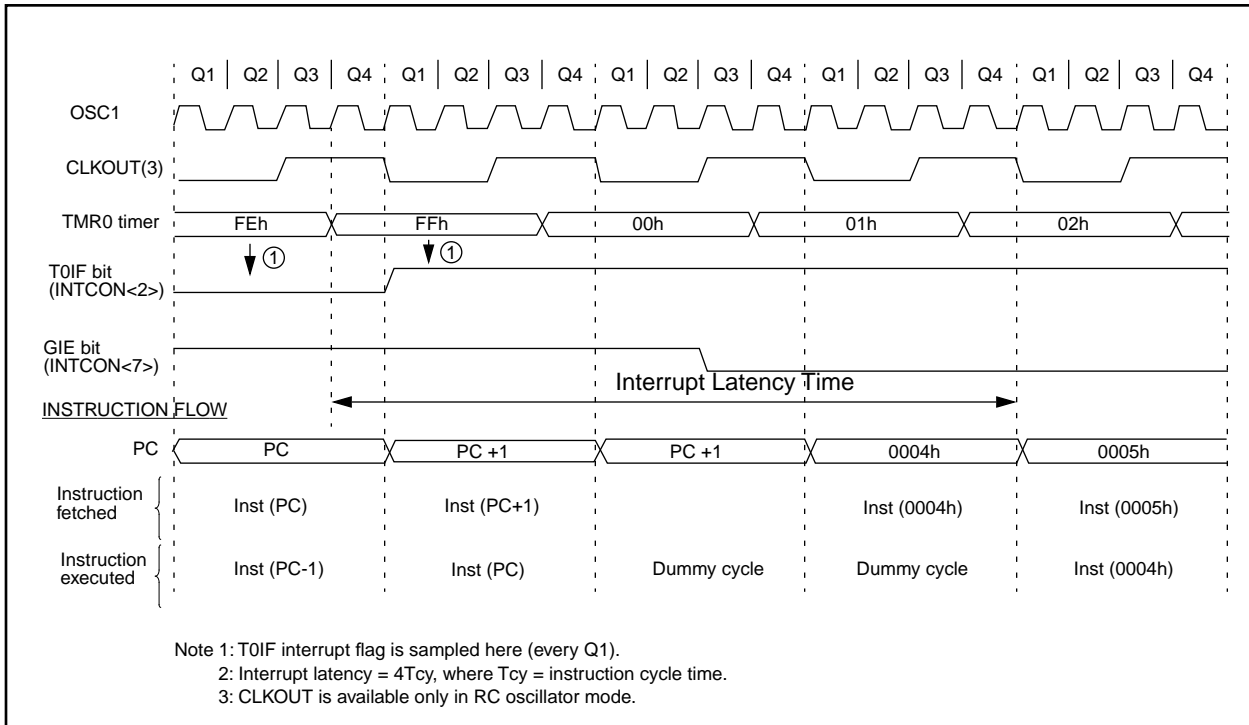

FIGURE 6-4: TIMER0 INTERRUPT TIMING



6.2 Using Timer0 with External Clock

When an external clock input is used for Timer0, it must meet certain requirements. The external clock requirement is due to internal phase clock (TOSC) synchronization. Also, there is a delay in the actual incrementing of Timer0 after synchronization.

6.2.1 EXTERNAL CLOCK SYNCHRONIZATION

When no prescaler is used, the external clock input is the same as the prescaler output. The synchronization of T0CKI with the internal phase clocks is accomplished by sampling the prescaler output on the Q2 and Q4 cycles of the internal phase clocks (Figure 6-5). Therefore, it is necessary for T0CKI to be high for at least $2T_{OSC}$ (and a small RC delay of 20 ns) and low for at least $2T_{OSC}$ (and a small RC delay of 20 ns). Refer to the electrical specification of the desired device.

When a prescaler is used, the external clock input is divided by the asynchronous ripple-counter type prescaler so that the prescaler output is symmetrical. For the external clock to meet the sampling requirement, the ripple-counter must be taken into account. Therefore, it is necessary for T0CKI to have a period of at least $4T_{OSC}$ (and a small RC delay of 40 ns) divided by the prescaler value. The only requirement on T0CKI high and low time is that they do not violate the minimum pulse width requirement of 10 ns. Refer to parameters 40, 41 and 42 in the electrical specification of the desired device.

6.2.2 TIMER0 INCREMENT DELAY

Since the prescaler output is synchronized with the internal clocks, there is a small delay from the time the external clock edge occurs to the time the TMR0 is actually incremented. Figure 6-5 shows the delay from the external clock edge to the timer incrementing.

FIGURE 6-5: TIMER0 TIMING WITH EXTERNAL CLOCK

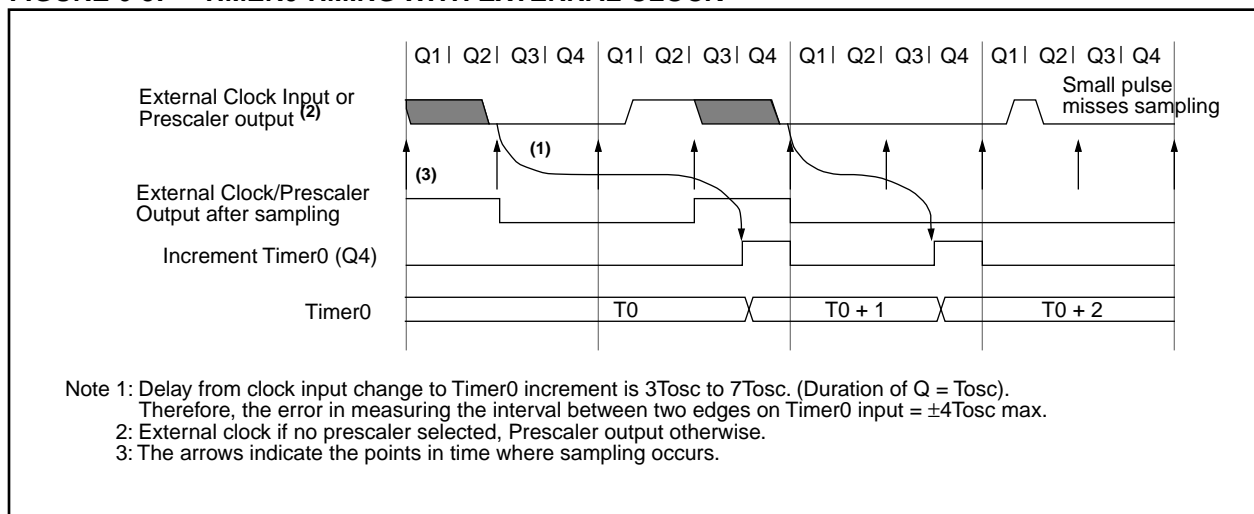

PIC16C55X(A)

6.3 Prescaler

An 8-bit counter is available as a prescaler for the Timer0 module, or as a postscaler for the Watchdog Timer, respectively (Figure 6-6). For simplicity, this counter is being referred to as “prescaler” throughout this data sheet. Note that there is only one prescaler available which is mutually exclusive between the Timer0 module and the Watchdog Timer. Thus, a prescaler assignment for the Timer0 module means that there is no prescaler for the Watchdog Timer, and vice-versa.

The PSA and PS2:PS0 bits (OPTION<3:0>) determine the prescaler assignment and prescale ratio.

When assigned to the Timer0 module, all instructions writing to the TMR0 register (e.g., CLRF 1, MOVWF 1, BSF 1,x,...etc.) will clear the prescaler. When assigned to WDT, a CLRWDT instruction will clear the prescaler along with the Watchdog Timer. The prescaler is not readable or writable.

FIGURE 6-6: BLOCK DIAGRAM OF THE TIMER0/WDT PRESCALER

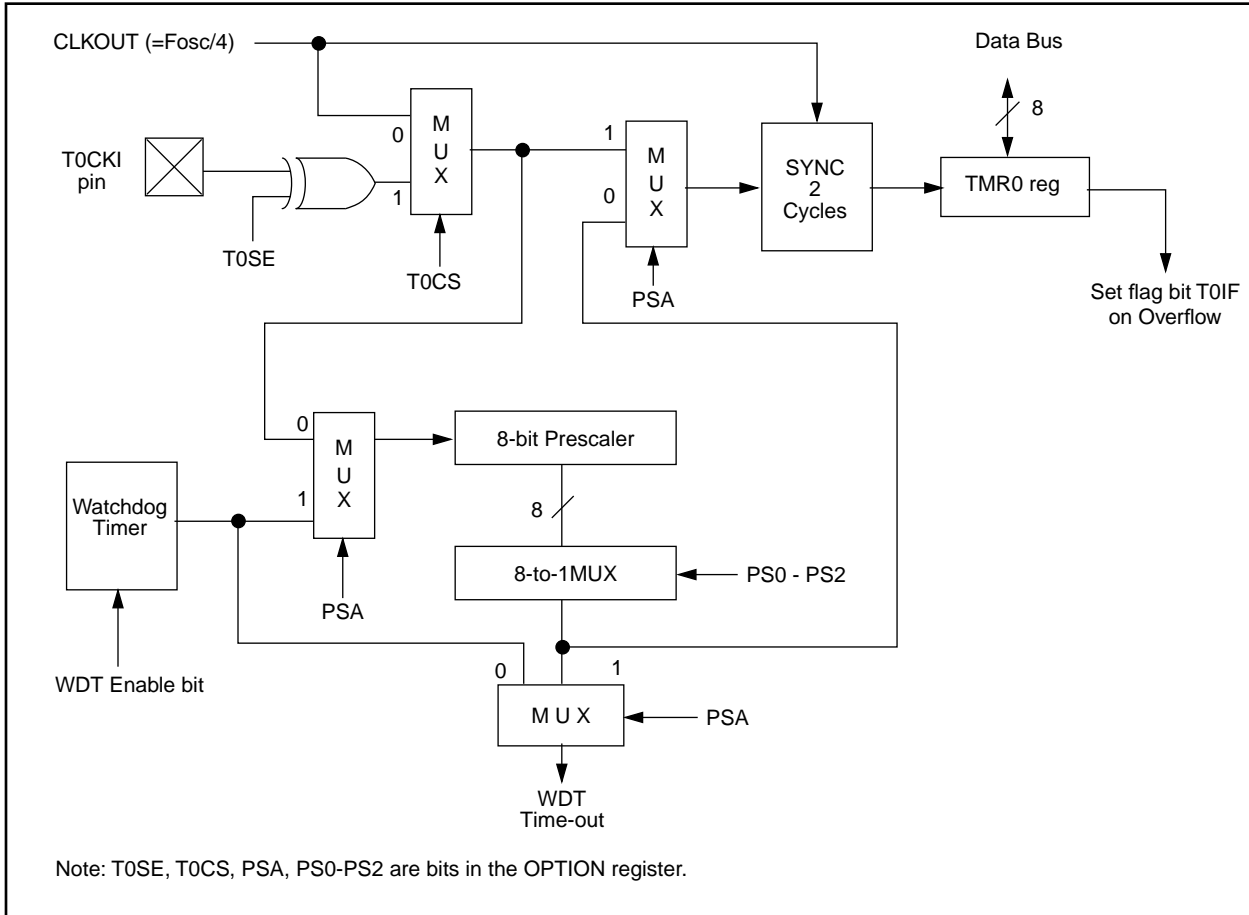

6.3.1 SWITCHING PRESCALER ASSIGNMENT

The prescaler assignment is fully under software control (i.e., it can be changed “on the fly” during program execution). To avoid an unintended device RESET, the following instruction sequence (Example 6-1) must be executed when changing the prescaler assignment from Timer0 to WDT. Lines 5-7 are required only if the desired postscaler rate is 1:1 (PS<2:0> = 000) or 1:2 (PS<2:0> = 001).

EXAMPLE 6-1: CHANGING PRESCALER (TIMER0→WDT)

```

1.BCF STATUS, RP0 ;Skip if already in
   ; Bank 0
2.CLRWDT ;Clear WDT
3.CLRF TMR0 ;Clear TMR0 & Prescaler
4.BSF STATUS, RP0 ;Bank 1
5.MOVLW '00101111'b; ;These 3 lines (5, 6, 7)
6.MOVWF OPTION ; are required only if
   ; desired PS<2:0> are
7.CLRWDT ; 000 or 001
8.MOVLW '00101xxx'b ;Set Postscaler to
9.MOVWF OPTION ; desired WDT rate
10.BCF STATUS, RP0 ;Return to Bank 0
    
```

To change prescaler from the WDT to the TMR0 module use the sequence shown in Example 6-2. This precaution must be taken even if the WDT is disabled.

EXAMPLE 6-2: CHANGING PRESCALER (WDT→TIMER0)

```

CLRWDT ;Clear WDT and
   ;prescaler
BSF STATUS, RP0
MOVLW b'xxxx0xxx' ;Select TMR0, new
   ;prescale value and
   ;clock source

MOVWF OPTION
BCF STATUS, RP0
    
```

TABLE 6-1: REGISTERS ASSOCIATED WITH TIMER0

| Address | Name | Bit 7 | Bit 6 | Bit 5 | Bit 4 | Bit 3 | Bit 2 | Bit 1 | Bit 0 | Value on POR | Value on All Other Resets |
|---------|--------|--------------------------|--------|-------|--------|--------|--------|--------|--------|--------------|---------------------------|
| 01h | TMR0 | Timer0 module's register | | | | | | | | uuuu uuuu | xxxx xxxx |
| 0Bh/8Bh | INTCON | GIE | + | TOIE | INTE | RBIE | T0IF | INTF | RBIF | 0000 000x | 0000 000x |
| 81h | OPTION | RBPU | INTEDG | T0CS | T0SE | PSA | PS2 | PS1 | PS0 | 1111 1111 | 1111 1111 |
| 85h | TRISA | — | — | — | TRISA4 | TRISA3 | TRISA2 | TRISA1 | TRISA0 | ---1 1111 | ---1 1111 |

Legend: — = Unimplemented locations, read as '0'.

+ = Reserved for future use.

Note: Shaded bits are not used by TMR0 module.

PIC16C55X(A)

NOTES:

7.0 SPECIAL FEATURES OF THE CPU

What sets a microcontroller apart from other processors are special circuits to deal with the needs of real time applications. The PIC16C55X(A) family has a host of such features intended to maximize system reliability, minimize cost through elimination of external components, provide power saving operating modes and offer code protection.

These are:

1. OSC selection
2. Reset
 - Power-on Reset (POR)
 - Power-up Timer (PWRT)
 - Oscillator Start-Up Timer (OST)
3. Interrupts
4. Watchdog Timer (WDT)
5. SLEEP
6. Code protection
7. ID Locations
8. In-circuit serial programming™

The PIC16C55X(A) has a Watchdog Timer which is controlled by configuration bits. It runs off its own RC oscillator for added reliability. There are two timers that offer necessary delays on power-up. One is the Oscillator Start-up Timer (OST), intended to keep the chip in reset until the crystal oscillator is stable. The other is the Power-up Timer (PWRT), which provides a fixed delay of 72 ms (nominal) on power-up only, designed to keep the part in reset while the power supply stabilizes. With these two functions on-chip, most applications need no external reset circuitry.

The SLEEP mode is designed to offer a very low current power-down mode. The user can wake-up from SLEEP through external reset, Watchdog Timer wake-up or through an interrupt. Several oscillator options are also made available to allow the part to fit the application. The RC oscillator option saves system cost while the LP crystal option saves power. A set of configuration bits are used to select various options.

PIC16C55X(A)

7.1 Configuration Bits

The configuration bits can be programmed (read as '0') or left unprogrammed (read as '1') to select various device configurations. These bits are mapped in program memory location 2007h.

The user will note that address 2007h is beyond the user program memory space. In fact, it belongs to the special test/configuration memory space (2000h – 3FFFh), which can be accessed only during programming.

FIGURE 7-1: CONFIGURATION WORD

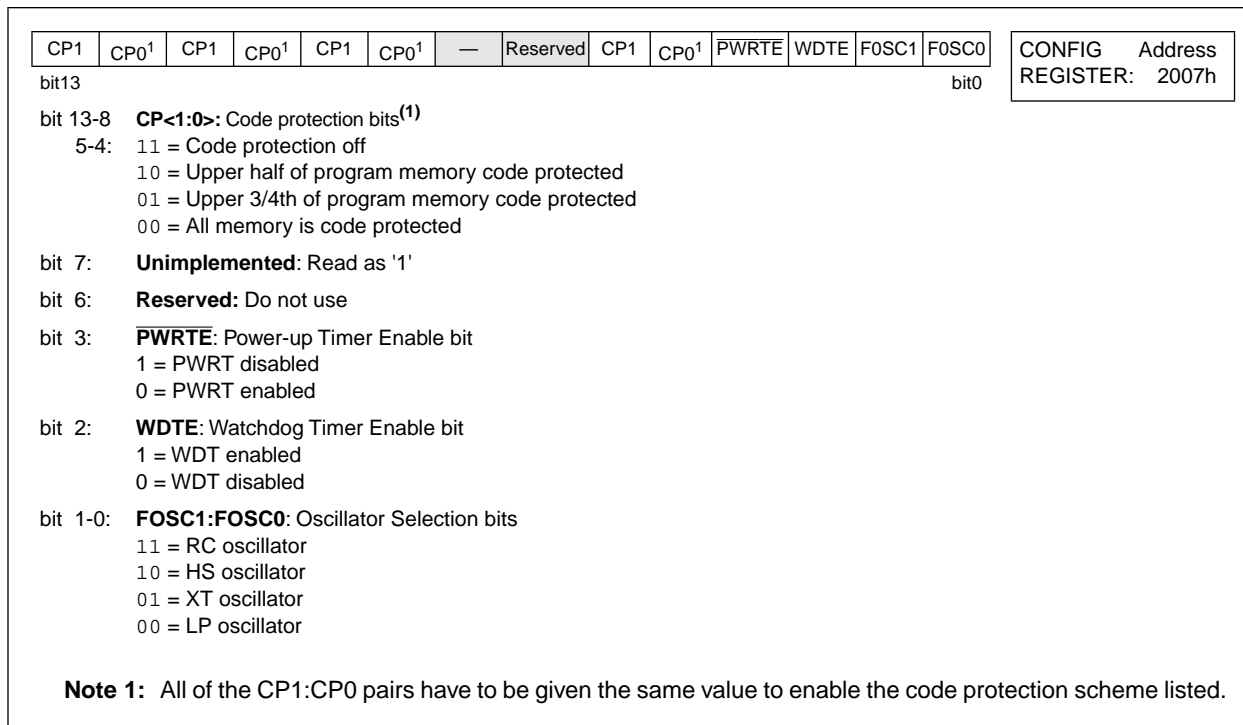

7.2 Oscillator Configurations

7.2.1 OSCILLATOR TYPES

The PIC16C55X(A) can be operated in four different oscillator options. The user can program two configuration bits (FOSC1 and FOSC0) to select one of these four modes:

- LP Low Power Crystal
- XT Crystal/Resonator
- HS High Speed Crystal/Resonator
- RC Resistor/Capacitor

7.2.2 CRYSTAL OSCILLATOR / CERAMIC RESONATORS

In XT, LP or HS modes a crystal or ceramic resonator is connected to the OSC1 and OSC2 pins to establish oscillation (Figure 7-2). The PIC16C55X(A) oscillator design requires the use of a parallel cut crystal. Use of a series cut crystal may give a frequency out of the crystal manufacturers specifications. When in XT, LP or HS modes, the device can have an external clock source to drive the OSC1 pin (Figure 7-3).

FIGURE 7-2: CRYSTAL OPERATION (OR CERAMIC RESONATOR) (HS, XT OR LP OSC CONFIGURATION)

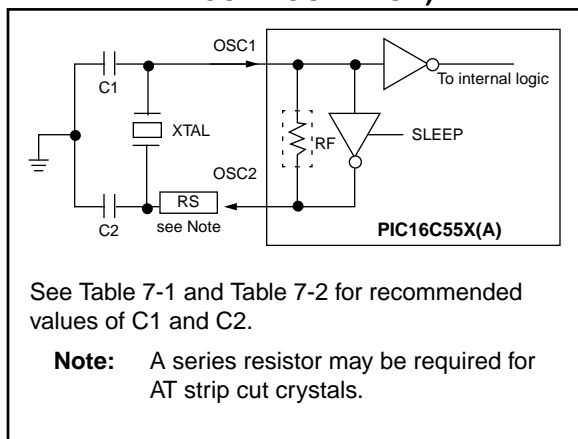

FIGURE 7-3: EXTERNAL CLOCK INPUT OPERATION (HS, XT OR LP OSC CONFIGURATION)

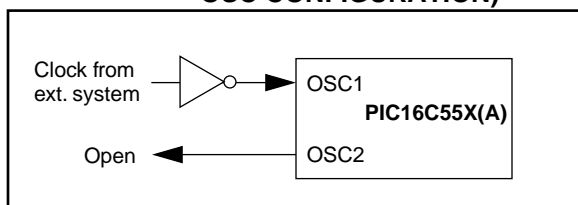

TABLE 7-1: CAPACITOR SELECTION FOR CERAMIC RESONATORS (PRELIMINARY)

| Ranges Characterized: | | | |
|-----------------------|----------|-------------|-------------|
| Mode | Freq | OSC1(C1) | OSC2(C2) |
| XT | 455 kHz | 22 - 100 pF | 22 - 100 pF |
| | 2.0 MHz | 15 - 68 pF | 15 - 68 pF |
| | 4.0 MHz | 15 - 68 pF | 15 - 68 pF |
| HS | 8.0 MHz | 10 - 68 pF | 10 - 68 pF |
| | 16.0 MHz | 10 - 22 pF | 10 - 22 pF |

Higher capacitance increases the stability of the oscillator but also increases the start-up time. These values are for design guidance only. Since each resonator has its own characteristics, the user should consult the resonator manufacturer for appropriate values of external components.

| Resonators to be Characterized: | | |
|---------------------------------|------------------------|-------|
| 455 kHz | Panasonic EFO-A455K04B | ±0.3% |
| 2.0 MHz | Murata Erie CSA2.00MG | ±0.5% |
| 4.0 MHz | Murata Erie CSA4.00MG | ±0.5% |
| 8.0 MHz | Murata Erie CSA8.00MT | ±0.5% |
| 16.0 MHz | Murata Erie CSA16.00MX | ±0.5% |

All resonators used did not have built-in capacitors.

TABLE 7-2: CAPACITOR SELECTION FOR CRYSTAL OSCILLATOR (PRELIMINARY)

| Mode | Freq | OSC1(C1) | OSC2(C2) |
|------|---------|-------------|--------------|
| LP | 32 kHz | 68 - 100 pF | 68 - 100 pF |
| | 200 kHz | 15 - 30 pF | 15 - 30 pF |
| XT | 100 kHz | 68 - 150 pF | 150 - 200 pF |
| | 2 MHz | 15 - 30 pF | 15 - 30 pF |
| | 4 MHz | 15 - 30 pF | 15 - 30 pF |
| HS | 8 MHz | 15 - 30 pF | 15 - 30 pF |
| | 10 MHz | 15 - 30 pF | 15 - 30 pF |
| | 20 MHz | 15 - 30 pF | 15 - 30 pF |

Higher capacitance increases the stability of the oscillator but also increases the start-up time. These values are for design guidance only. Rs may be required in HS mode as well as XT mode to avoid overdriving crystals with low drive level specification. Since each crystal has its own characteristics, the user should consult the crystal manufacturer for appropriate values of external components.

| Crystals to be Characterized: | | |
|-------------------------------|-----------------------|----------|
| 32.768 kHz | Epson C-001R32.768K-A | ± 20 PPM |
| 100 kHz | Epson C-2 100.00 KC-P | ± 20 PPM |
| 200 kHz | STD XTL 200.000 kHz | ± 20 PPM |
| 2.0 MHz | ECS ECS-20-S-2 | ± 50 PPM |
| 4.0 MHz | ECS ECS-40-S-4 | ± 50 PPM |
| 10.0 MHz | ECS ECS-100-S-4 | ± 50 PPM |
| 20.0 MHz | ECS ECS-200-S-4 | ± 50 PPM |

PIC16C55X(A)

7.2.3 EXTERNAL CRYSTAL OSCILLATOR CIRCUIT

Either a pre-packaged oscillator can be used or a simple oscillator circuit with TTL gates can be built. Prepackaged oscillators provide a wide operating range and better stability. A well-designed crystal oscillator will provide good performance with TTL gates. Two types of crystal oscillator circuits can be used; one with series resonance, or one with parallel resonance.

Figure 7-4 shows implementation of a parallel resonant oscillator circuit. The circuit is designed to use the fundamental frequency of the crystal. The 74AS04 inverter performs the 180° phase shift that a parallel oscillator requires. The 4.7 kΩ resistor provides the negative feedback for stability. The 10 kΩ potentiometers bias the 74AS04 in the linear region. This could be used for external oscillator designs.

FIGURE 7-4: EXTERNAL PARALLEL RESONANT CRYSTAL OSCILLATOR CIRCUIT

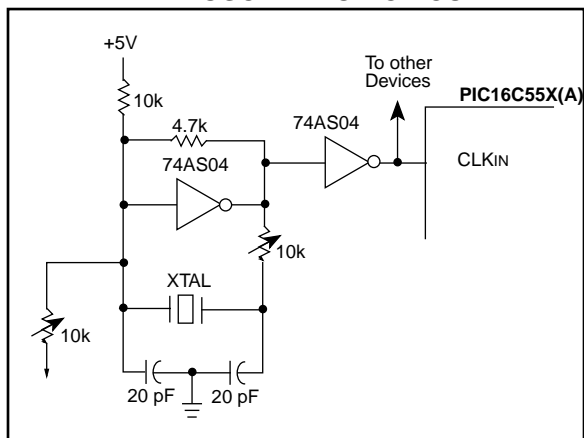
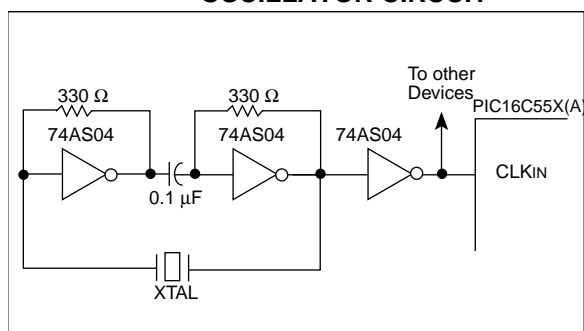

Figure 7-5 shows a series resonant oscillator circuit. This circuit is also designed to use the fundamental frequency of the crystal. The inverter performs a 180° phase shift in a series resonant oscillator circuit. The 330 Ω resistors provide the negative feedback to bias the inverters in their linear region.

FIGURE 7-5: EXTERNAL SERIES RESONANT CRYSTAL OSCILLATOR CIRCUIT



7.2.4 RC OSCILLATOR

For timing insensitive applications the “RC” device option offers additional cost savings. The RC oscillator frequency is a function of the supply voltage, the resistor (R_{ext}) and capacitor (C_{ext}) values, and the operating temperature. In addition to this, the oscillator frequency will vary from unit to unit due to normal process parameter variation. Furthermore, the difference in lead frame capacitance between package types will also affect the oscillation frequency, especially for low C_{ext} values. The user also needs to take into account variation due to tolerance of external R and C components used. Figure 7-6 shows how the R/C combination is connected to the PIC16C55X. For R_{ext} values below 2.2 kΩ, the oscillator operation may become unstable, or stop completely. For very high R_{ext} values (e.g., 1 MΩ), the oscillator becomes sensitive to noise, humidity and leakage. Thus, we recommend to keep R_{ext} between 3 kΩ and 100 kΩ.

Although the oscillator will operate with no external capacitor ($C_{ext} = 0$ pF), we recommend using values above 20 pF for noise and stability reasons. With no or small external capacitance, the oscillation frequency can vary dramatically due to changes in external capacitances, such as PCB trace capacitance or package lead frame capacitance.

The oscillator frequency, divided by 4, is available on the OSC2/CLKOUT pin, and can be used for test purposes or to synchronize other logic (Figure 3-2 for waveform).

FIGURE 7-6: RC OSCILLATOR MODE

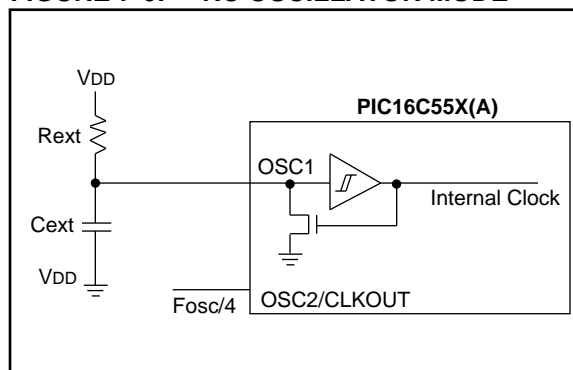

7.3 Reset

The PIC16C55X(A) differentiates between various kinds of reset:

- Power-on reset (POR)
- $\overline{\text{MCLR}}$ reset during normal operation
- $\overline{\text{MCLR}}$ reset during SLEEP
- WDT reset (normal operation)
- WDT wake-up (SLEEP)

Some registers are not affected in any reset condition; their status is unknown on POR and unchanged in any other reset. Most other registers are reset to a "reset state" on Power-on reset, on $\overline{\text{MCLR}}$ or WDT reset and

on $\overline{\text{MCLR}}$ reset during SLEEP. They are not affected by a WDT wake-up, since this is viewed as the resumption of normal operation. TO and PD bits are set or cleared differently in different reset situations as indicated in Table 7-4. These bits are used in software to determine the nature of the reset. See Table 7-6 for a full description of reset states of all registers.

A simplified block diagram of the on-chip reset circuit is shown in Figure 7-7.

The $\overline{\text{MCLR}}$ reset path has a noise filter to detect and ignore small pulses. See Table 10-4 for pulse width specification.

FIGURE 7-7: SIMPLIFIED BLOCK DIAGRAM OF ON-CHIP RESET CIRCUIT

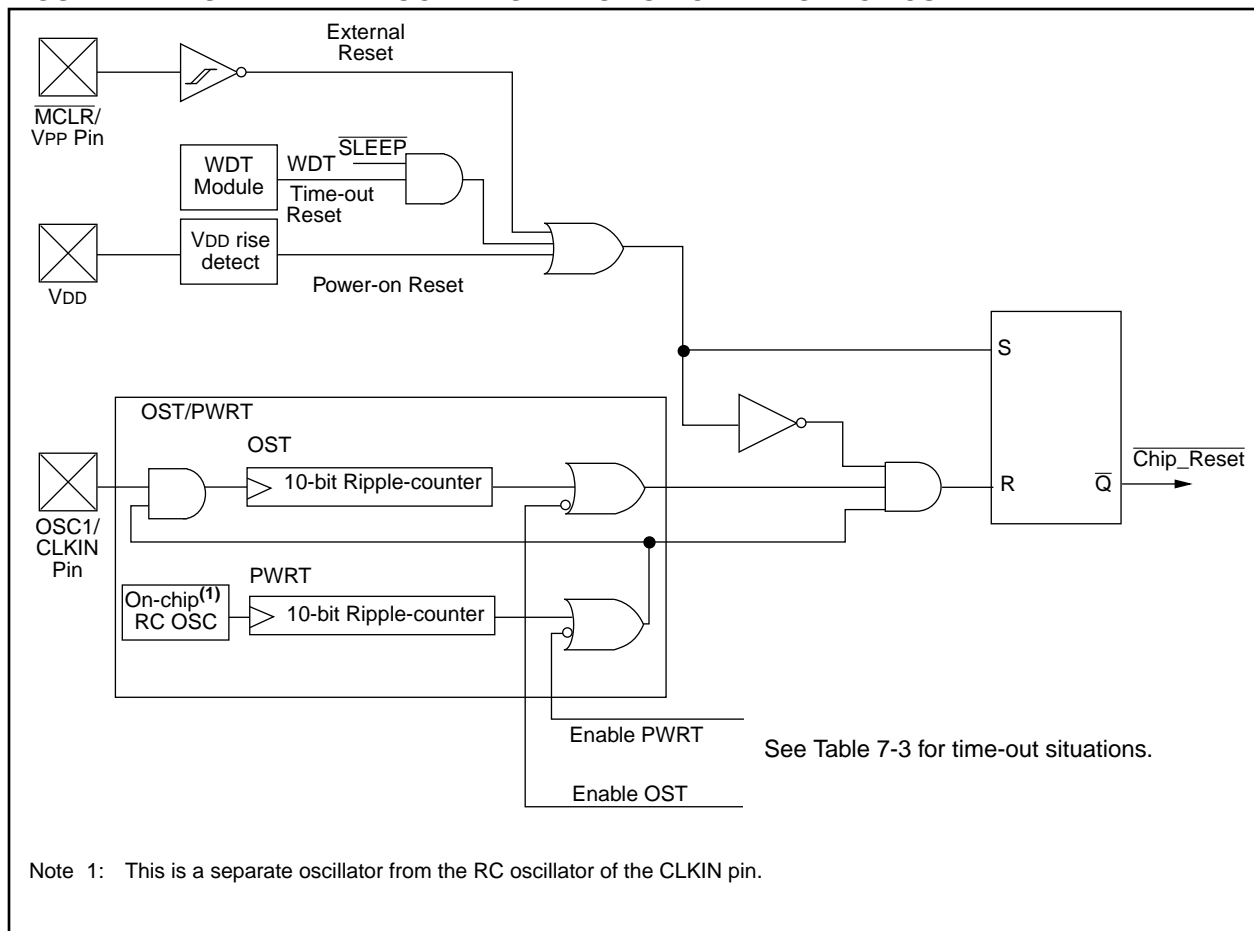

PIC16C55X(A)

7.4 Power-on Reset (POR), Power-up Timer (PWRT), Oscillator Start-up Timer (OST)

7.4.1 POWER-ON RESET (POR)

A Power-on Reset pulse is generated on-chip when VDD rise is detected (in the range of 1.6 V – 1.8 V). To take advantage of the POR, just tie the $\overline{\text{MCLR}}$ pin directly (or through a resistor) to VDD. This will eliminate external RC components usually needed to create Power-on Reset. A maximum rise time for VDD is required. See Electrical Specifications for details.

The POR circuit does not produce internal reset when VDD declines.

When the device starts normal operation (exits the reset condition), device operating parameters (voltage, frequency, temperature, etc.) must be met to ensure operation. If these conditions are not met, the device must be held in reset until the operating conditions are met.

For additional information, refer to Application Note AN607 "Power-up Trouble Shooting".

7.4.2 POWER-UP TIMER (PWRT)

The Power-up Timer provides a fixed 72 ms (nominal) time-out on power-up only, from POR. The Power-up Timer operates on an internal RC oscillator. The chip is kept in reset as long as PWRT is active. The PWRT delay allows the VDD to rise to an acceptable level. A configuration bit, $\overline{\text{PWRTE}}$ can disable (if set) or enable (if cleared or programmed) the Power-up Timer. The Power-Up Time delay will vary from chip to chip and due to VDD, temperature and process variation. See DC parameters for details.

7.4.3 OSCILLATOR START-UP TIMER (OST)

The Oscillator Start-Up Timer (OST) provides a 1024 oscillator cycle (from OSC1 input) delay after the PWRT delay is over. This ensures that the crystal oscillator or resonator has started and stabilized.

The OST time-out is invoked only for XT, LP and HS modes and only on power-on reset or wake-up from SLEEP.

7.4.4 TIME-OUT SEQUENCE

On power-up, the time-out sequence is as follows: First PWRT time-out is invoked after POR has expired, then OST is activated. The total time-out will vary based on oscillator configuration and $\overline{\text{PWRTE}}$ bit status. For example, in RC mode with $\overline{\text{PWRTE}}$ bit erased (PWRT disabled), there will be no time-out at all. Figure 7-8, Figure 7-9 and Figure 7-10 depict time-out sequences.

Since the time-outs occur from the POR pulse, if $\overline{\text{MCLR}}$ is kept low long enough, the time-outs will expire. Then bringing $\overline{\text{MCLR}}$ high will begin execution immediately (see Figure 7-9). This is useful for testing purposes or to synchronize more than one PIC16C55X device operating in parallel.

Table 7-5 shows the reset conditions for some special registers, while Table 7-6 shows the reset conditions for all the registers.

7.4.5 POWER CONTROL/STATUS REGISTER (PCON)

Bit1 is $\overline{\text{POR}}$ (Power-on-reset). It is a '0' on power-on-reset and unaffected otherwise. The user must write a '1' to this bit following a power-on-reset. On a subsequent reset if $\overline{\text{POR}}$ is '0', it will indicate that a power-on-reset must have occurred (V_{DD} may have gone too low).

TABLE 7-3: TIME-OUT IN VARIOUS SITUATIONS

| Oscillator Configuration | Power-up | | Wake-up from SLEEP |
|--------------------------|------------------------------|------------------------------|--------------------|
| | $\overline{\text{PWRT}} = 0$ | $\overline{\text{PWRT}} = 1$ | |
| XT, HS, LP | 72 ms + 1024 Tosc | 1024 Tosc | 1024 Tosc |
| RC | 72 ms | — | — |

TABLE 7-4: STATUS BITS AND THEIR SIGNIFICANCE

| $\overline{\text{POR}}$ | $\overline{\text{TO}}$ | $\overline{\text{PD}}$ | |
|-------------------------|------------------------|------------------------|---|
| 0 | 1 | 1 | Power-on-reset |
| 0 | 0 | X | Illegal, $\overline{\text{TO}}$ is set on $\overline{\text{POR}}$ |
| 0 | X | 0 | Illegal, $\overline{\text{PD}}$ is set on $\overline{\text{POR}}$ |
| 1 | 0 | 1 | WDT Reset |
| 1 | 0 | 0 | WDT Wake-up |
| 1 | 1 | 1 | $\overline{\text{MCLR}}$ reset during normal operation |
| 1 | 1 | 0 | $\overline{\text{MCLR}}$ reset during SLEEP |

PIC16C55X(A)

TABLE 7-5: INITIALIZATION CONDITION FOR SPECIAL REGISTERS

| Condition | Program Counter | STATUS Register | PCON Register |
|------------------------------------|-----------------------|-----------------|---------------|
| Power-on Reset | 000h | 0001 1xxx | ---- --0- |
| MCLR reset during normal operation | 000h | 0001 1uuu | ---- --u- |
| MCLR reset during SLEEP | 000h | 0001 0uuu | ---- --u- |
| WDT reset | 000h | 0000 1uuu | ---- --u- |
| WDT Wake-up | PC + 1 | uuu0 0uuu | ---- --u- |
| Interrupt Wake-up from SLEEP | PC + 1 ⁽¹⁾ | uuu1 0uuu | ---- --u- |

Legend: u = unchanged, x = unknown, - = unimplemented bit, reads as '0'.

Note 1: When the wake-up is due to an interrupt and global enable bit, GIE is set, the PC is loaded with the interrupt vector (0004h) after execution of PC+1.

TABLE 7-6: INITIALIZATION CONDITION FOR REGISTERS

| Register | Address | Power-on Reset | <ul style="list-style-type: none"> • MCLR Reset during normal operation • MCLR Reset during SLEEP • WDT Reset | <ul style="list-style-type: none"> • Wake up from SLEEP through interrupt • Wake up from SLEEP through WDT time-out |
|----------|---------|----------------|--|---|
| W | - | xxxx xxxx | uuuu uuuu | uuuu uuuu |
| INDF | 00h | - | - | - |
| TMRO | 01h | xxxx xxxx | uuuu uuuu | uuuu uuuu |
| PCL | 02h | 0000 0000 | 0000 0000 | PC + 1 ⁽²⁾ |
| STATUS | 03h | 0001 1xxx | 000q quuu ⁽³⁾ | uuuq quuu ⁽³⁾ |
| FSR | 04h | xxxx xxxx | uuuu uuuu | uuuu uuuu |
| PORTA | 05h | ---x xxxx | ---u uuuu | ---u uuuu |
| PORTB | 06h | xxxx xxxx | uuuu uuuu | uuuu uuuu |
| PCLATH | 0Ah | ---0 0000 | ---0 0000 | ---u uuuu |
| INTCON | 0Bh | 0000 000x | 0000 000x | uuuu uuuu ⁽¹⁾ |
| OPTION | 81h | 1111 1111 | 1111 1111 | uuuu uuuu |
| TRISA | 85h | ---1 1111 | ---1 1111 | ---u uuuu |
| TRISB | 86h | 1111 1111 | 1111 1111 | uuuu uuuu |
| PCON | 8Eh | ---- --0- | ---- --u- | ---- --u- |

Legend: u = unchanged, x = unknown, - = unimplemented bit, reads as '0', q = value depends on condition.

Note 1: One or more bits in INTCON will be affected (to cause wake-up).

2: When the wake-up is due to an interrupt and the GIE bit is set, the PC is loaded with the interrupt vector (0004h).

3: See Table 7-5 for reset value for specific condition.

FIGURE 7-8: TIME-OUT SEQUENCE ON POWER-UP ($\overline{\text{MCLR}}$ NOT TIED TO V_{DD}): CASE 1

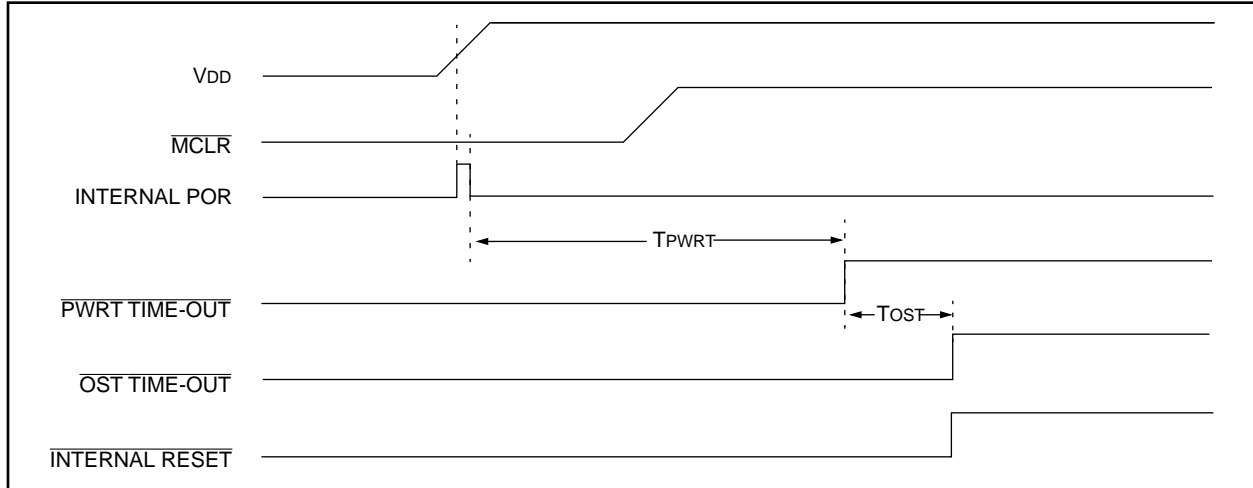

FIGURE 7-9: TIME-OUT SEQUENCE ON POWER-UP ($\overline{\text{MCLR}}$ NOT TIED TO V_{DD}): CASE 2

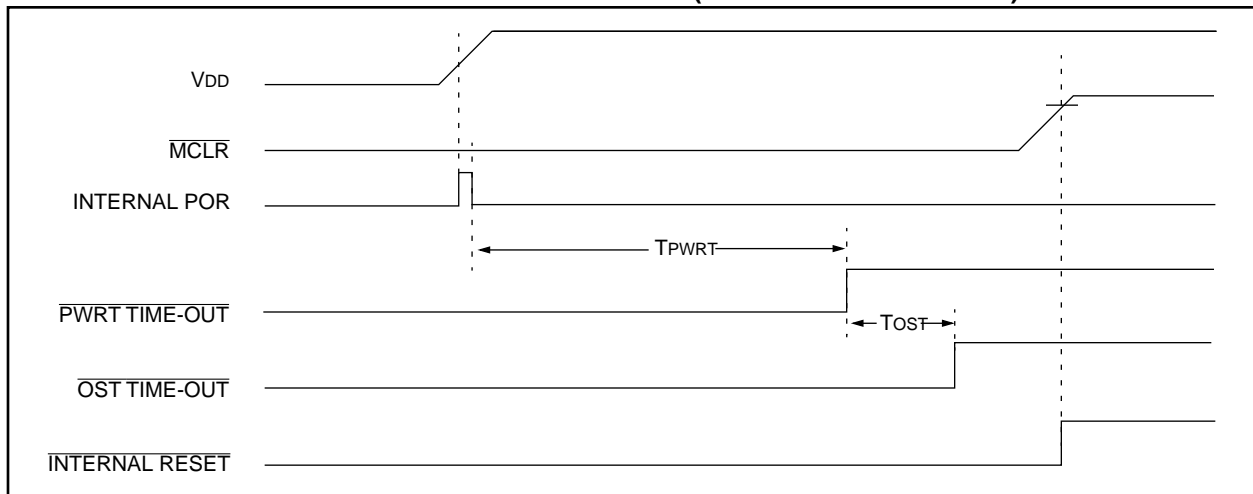
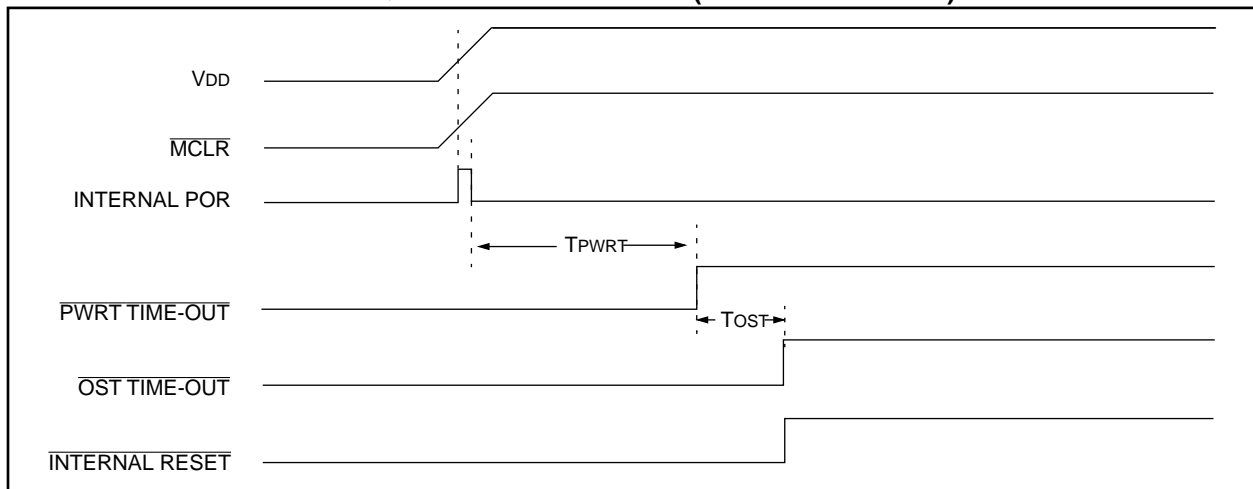
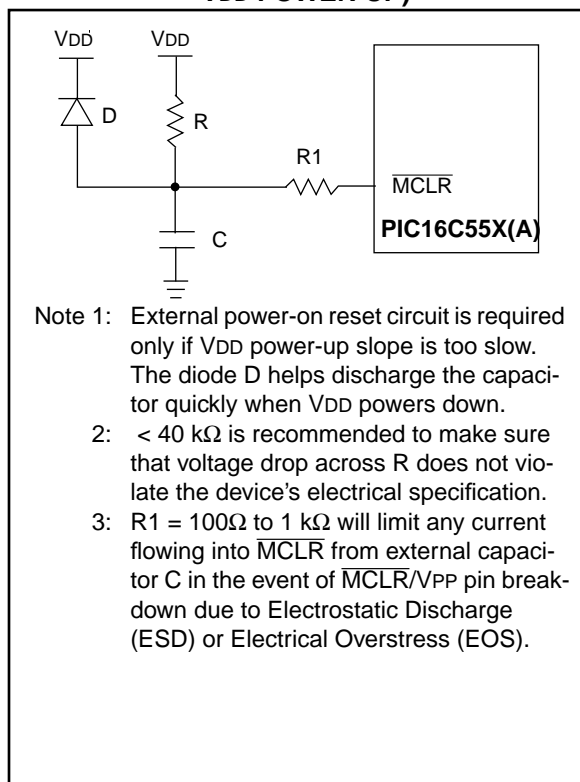

FIGURE 7-10: TIME-OUT SEQUENCE ON POWER-UP ($\overline{\text{MCLR}}$ TIED TO V_{DD}): CASE 3



PIC16C55X(A)

**FIGURE 7-11: EXTERNAL POWER-ON
RESET CIRCUIT (FOR SLOW
V_{DD} POWER-UP)**



7.5 Interrupts

The PIC16C55X(A) has 3 sources of interrupt:

- External interrupt RB0/INT
- TMR0 overflow interrupt
- PortB change interrupts (pins RB7:RB4)

The interrupt control register (INTCON) records individual interrupt requests in flag bits. It also has individual and global interrupt enable bits.

A global interrupt enable bit, GIE (INTCON<7>) enables (if set) all un-masked interrupts or disables (if cleared) all interrupts. Individual interrupts can be disabled through their corresponding enable bits in INTCON register. GIE is cleared on reset.

The “return from interrupt” instruction, RETFIE, exits the interrupt routine as well as sets the GIE bit, which re-enables RB0/INT interrupts.

The INT pin interrupt, the RB port change interrupt and the TMR0 overflow interrupt flags are contained in the INTCON register.

When an interrupt is responded to, the GIE is cleared to disable any further interrupt, the return address is pushed into the stack and the PC is loaded with 0004h. Once in the interrupt service routine the source(s) of the interrupt can be determined by polling the interrupt flag bits. The interrupt flag bit(s) must be cleared in software before re-enabling interrupts to avoid RB0/INT recursive interrupts.

For external interrupt events, such as the INT pin or PORTB change interrupt, the interrupt latency will be three or four instruction cycles. The exact latency depends when the interrupt event occurs (Figure 7-13). The latency is the same for one or two cycle instructions. Once in the interrupt service routine the source(s) of the interrupt can be determined by polling the interrupt flag bits. The interrupt flag bit(s) must be cleared in software before re-enabling interrupts to avoid multiple interrupt requests. Individual interrupt flag bits are set regardless of the status of their corresponding mask bit or the GIE bit.

Note 1: Individual interrupt flag bits are set regardless of the status of their corresponding mask bit or the GIE bit.

2: When an instruction that clears the GIE bit is executed, any interrupts that were pending for execution in the next cycle are ignored. The CPU will execute a NOP in the cycle immediately following the instruction which clears the GIE bit. The interrupts which were ignored are still pending to be serviced when the GIE bit is set again.

FIGURE 7-12: INTERRUPT LOGIC

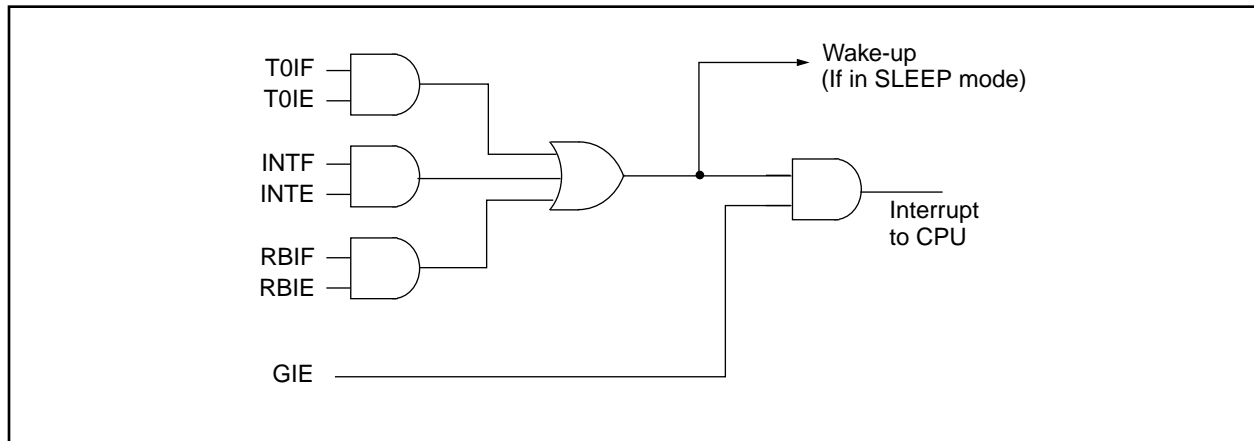

PIC16C55X(A)

7.5.1 RB0/INT INTERRUPT

An external interrupt on RB0/INT pin is edge triggered: either rising if INTEDG bit (OPTION<6>) is set, or falling if INTEDG bit is clear. When a valid edge appears on the RB0/INT pin, the INTF bit (INTCON<1>) is set. This interrupt can be disabled by clearing the INTE control bit (INTCON<4>). The INTF bit must be cleared in software in the interrupt service routine before re-enabling this interrupt. The RB0/INT interrupt can wake-up the processor from SLEEP, if the INTE bit was set prior to going into SLEEP. The status of the GIE bit decides whether or not the processor branches to the interrupt vector following wake-up. See Section 7.8 for details on SLEEP and Figure 7-16 for timing of wake-up from SLEEP through RB0/INT interrupt.

7.5.2 TMR0 INTERRUPT

An overflow (FFh → 00h) in the TMR0 register will set the T0IF (INTCON<2>) bit. The interrupt can be enabled/disabled by setting/clearing T0IE (INTCON<5>) bit. For operation of the Timer0 module, see Section 6.0.

7.5.3 PORTB INTERRUPT

An input change on PORTB <7:4> sets the RBIF (INTCON<0>) bit. The interrupt can be enabled/disabled by setting/clearing the RBIE (INTCON<4>) bit. For operation of PORTB (Section 5.2).

Note: If a change on the I/O pin should occur when the read operation is being executed (start of the Q2 cycle), then the RBIF interrupt flag may get set.

FIGURE 7-13: INT PIN INTERRUPT TIMING

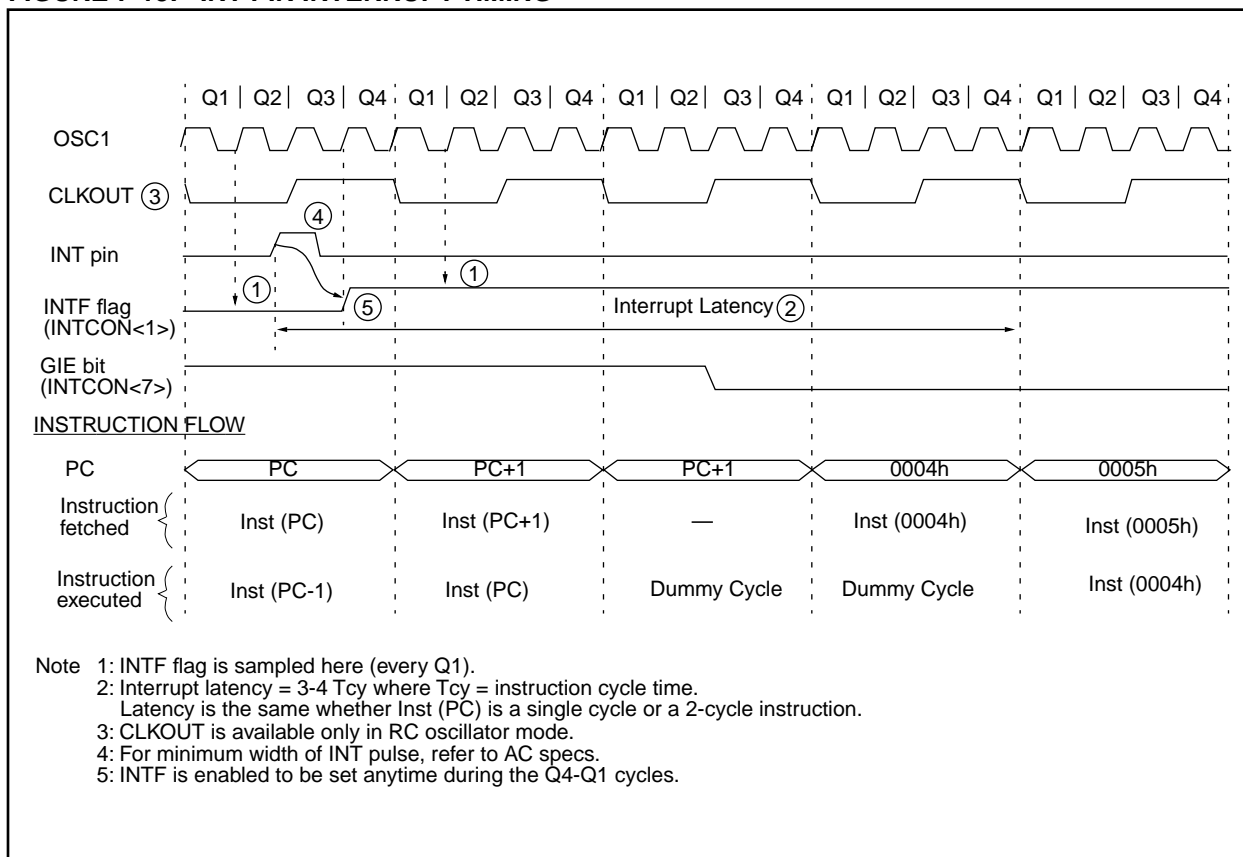

7.6 Context Saving During Interrupts

During an interrupt, only the return PC value is saved on the stack. Typically, users may wish to save key registers during an interrupt, e.g. W register and STATUS register. This will have to be implemented in software.

Example 7-1 stores and restores the STATUS and W registers. The user register, W_TEMP, must be defined in both banks and must be defined at the same offset from the bank base address (i.e., W_TEMP is defined at 0x20 in Bank 0 and it must also be defined at 0xA0 in Bank 1). The user register, STATUS_TEMP, must be defined in Bank 0. The Example 7-1:

- Stores the W register
- Stores the STATUS register in Bank 0
- Executes the ISR code
- Restores the STATUS (and bank select bit register)
- Restores the W register

EXAMPLE 7-1: SAVING THE STATUS AND W REGISTERS IN RAM

```

MOVWF    W_TEMP        ;copy W to temp register,
                       ;could be in either bank

SWAPF    STATUS,W      ;swap status to be saved into W

BCF      STATUS,RP0    ;change to bank 0 regardless
                       ;of current bank

MOVWF    STATUS_TEMP   ;save status to bank 0
                       ;register

:
:   (ISR)
:

SWAPF    STATUS_TEMP,W ;swap STATUS_TEMP register
                       ;into W, sets bank to original
                       ;state

MOVWF    STATUS        ;move W into STATUS register

SWAPF    W_TEMP,F      ;swap W_TEMP

SWAPF    W_TEMP,W      ;swap W_TEMP into W
    
```

7.7 Watchdog Timer (WDT)

The watchdog timer is a free running on-chip RC oscillator which does not require any external components. This RC oscillator is separate from the RC oscillator of the CLKIN pin. That means that the WDT will run, even if the clock on the OSC1 and OSC2 pins of the device has been stopped, for example, by execution of a SLEEP instruction. During normal operation, a WDT time-out generates a device RESET. If the device is in SLEEP mode, a WDT time-out causes the device to wake-up and continue with normal operation. The WDT can be permanently disabled by programming the configuration bit WDTE as clear (Section 7.1).

7.7.1 WDT PERIOD

The WDT has a nominal time-out period of 18 ms, (with no prescaler). The time-out periods vary with temperature, VDD and process variations from part to part (see DC specs). If longer time-out periods are desired, a prescaler with a division ratio of up to 1:128 can be assigned to the WDT under software control by writing to the OPTION register. Thus, time-out periods up to 2.3 seconds can be realized.

The CLRWDT and SLEEP instructions clear the WDT and the postscaler, if assigned to the WDT, and prevent it from timing out and generating a device RESET.

The \overline{TO} bit in the STATUS register will be cleared upon a Watchdog Timer time-out.

7.7.2 WDT PROGRAMMING CONSIDERATIONS

It should also be taken in account that under worst case conditions (VDD = Min., Temperature = Max., max. WDT prescaler) it may take several seconds before a WDT time-out occurs.

PIC16C55X(A)

FIGURE 7-14: WATCHDOG TIMER BLOCK DIAGRAM

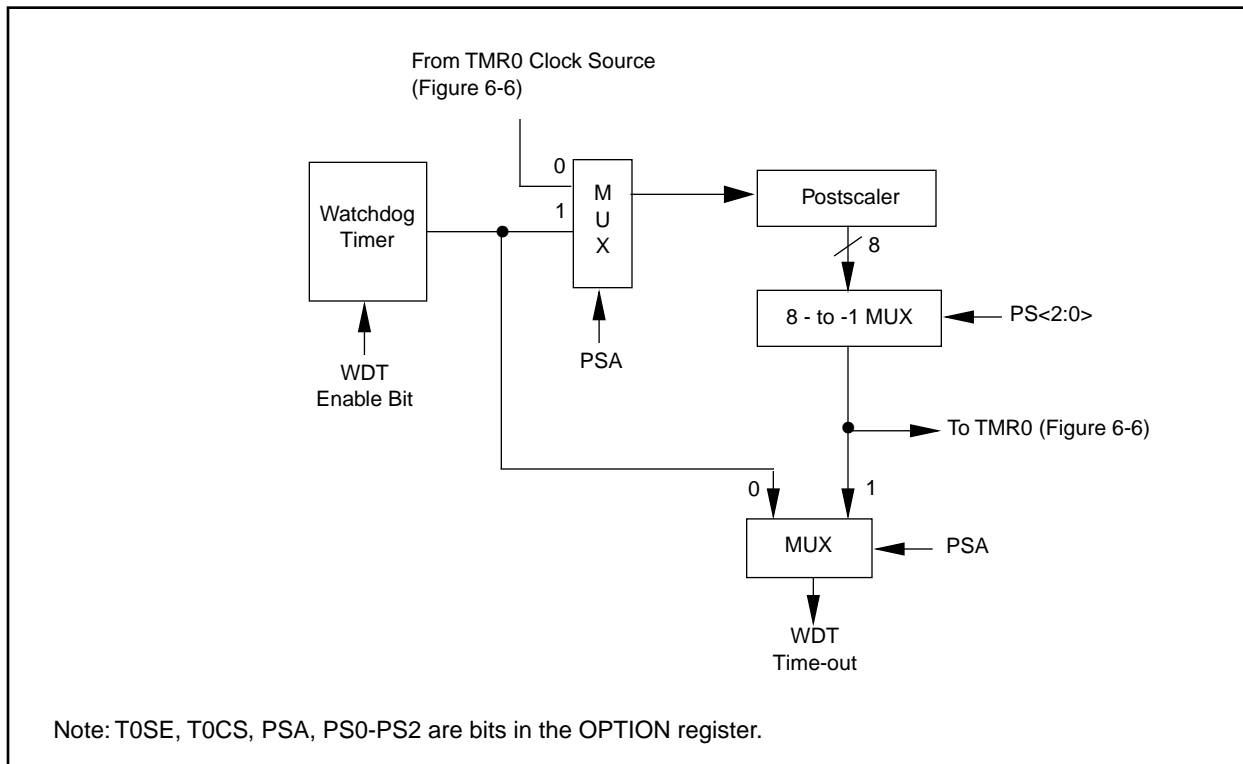

FIGURE 7-15: SUMMARY OF WATCHDOG TIMER REGISTERS

| Address | Name | Bit 7 | Bit 6 | Bit 5 | Bit 4 | Bit 3 | Bit 2 | Bit 1 | Bit 0 |
|---------|--------------|---------------|--------|-------|-------|-------|-------|-------|-------|
| 2007h | Config. bits | — | + | CP1 | CP0 | PWRTE | WDTE | FOSC1 | FOSC0 |
| 81h | OPTION | RBP \bar{U} | INTEDG | T0CS | T0SE | PSA | PS2 | PS1 | PS0 |

Legend: Shaded cells are not used by the Watchdog Timer.

— = Unimplemented location, read as '0'.

+ = Reserved for future use.

7.8 Power-Down Mode (SLEEP)

The Power-down mode is entered by executing a SLEEP instruction.

If enabled, the Watchdog Timer will be cleared but keeps running, the \overline{PD} bit in the STATUS register is cleared, the \overline{TO} bit is set, and the oscillator driver is turned off. The I/O ports maintain the status they had, before SLEEP was executed (driving high, low, or hi-impedance).

For lowest current consumption in this mode, all I/O pins should be either at VDD, or VSS, with no external circuitry drawing current from the I/O pin. I/O pins that are hi-impedance inputs should be pulled high or low externally to avoid switching currents caused by floating inputs. The T0CKI input should also be at VDD or VSS for lowest current consumption. The contribution from on chip pull-ups on PORTB should be considered.

The \overline{MCLR} pin must be at a logic high level (V_{IHMC}).

Note: It should be noted that a RESET generated by a WDT time-out does not drive \overline{MCLR} pin low.

The first event will cause a device reset. The two latter events are considered a continuation of program execution. The \overline{TO} and \overline{PD} bits in the STATUS register can be used to determine the cause of device reset. \overline{PD} bit, which is set on power-up is cleared when SLEEP is invoked. \overline{TO} bit is cleared if WDT Wake-up occurred.

When the SLEEP instruction is being executed, the next instruction (PC + 1) is pre-fetched. For the device to wake-up through an interrupt event, the corresponding interrupt enable bit must be set (enabled). Wake-up is regardless of the state of the GIE bit. If the GIE bit is clear (disabled), the device continues execution at the instruction after the SLEEP instruction. If the GIE bit is set (enabled), the device executes the instruction after the SLEEP instruction and then branches to the interrupt address (0004h). In cases where the execution of the instruction following SLEEP is not desirable, the user should have a NOP after the SLEEP instruction.

Note: If the global interrupts are disabled (GIE is cleared), but any interrupt source has both its interrupt enable bit and the corresponding interrupt flag bits set, the device will immediately wakeup from sleep. The sleep instruction is completely executed.

7.8.1 WAKE-UP FROM SLEEP

The device can wake-up from SLEEP through one of the following events:

1. External reset input on \overline{MCLR} pin
2. Watchdog Timer Wake-up (if WDT was enabled)
3. Interrupt from RB0/INT pin or RB Port change

The WDT is cleared when the device wakes-up from sleep, regardless of the source of wake-up.

FIGURE 7-16: WAKE-UP FROM SLEEP THROUGH INTERRUPT

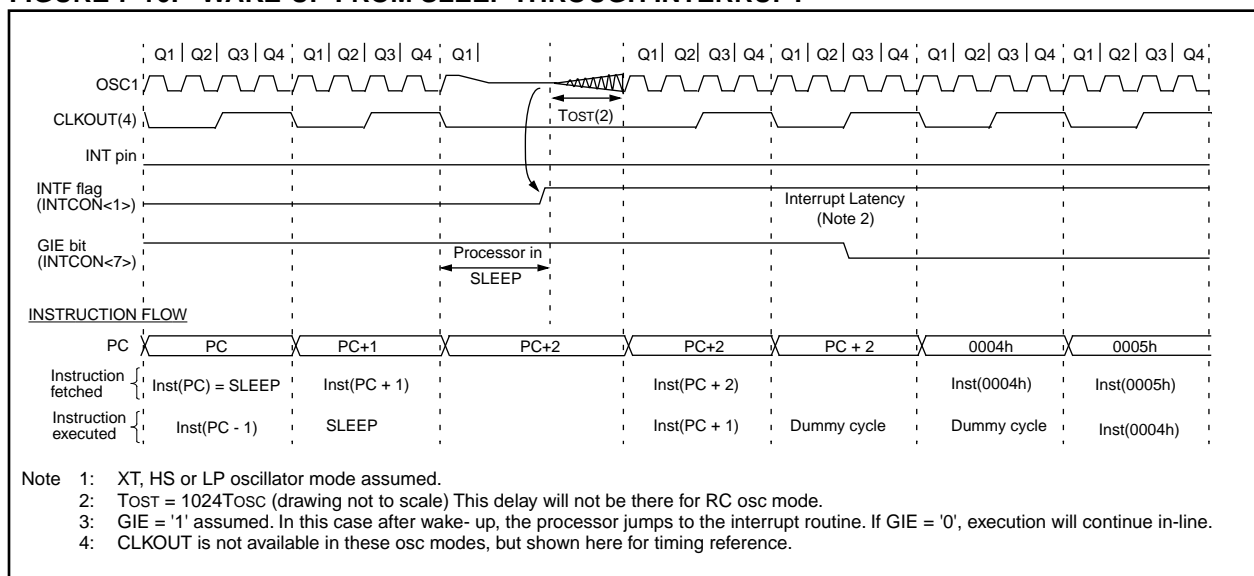

PIC16C55X(A)

7.9 Code Protection

If the code protection bit(s) have not been programmed, the on-chip program memory can be read out for verification purposes.

Note: Microchip does not recommend code protecting windowed devices.

7.10 ID Locations

Four memory locations (2000h-2003h) are designated as ID locations where the user can store checksum or other code-identification numbers. These locations are not accessible during normal execution but are readable and writable during program/verify. Only the least significant 4 bits of the ID locations are used.

7.11 In-Circuit Serial Programming™

The PIC16C55X(A) microcontrollers can be serially programmed while in the end application circuit. This is simply done with two lines for clock and data, and three other lines for power, ground, and the programming voltage. This allows customers to manufacture boards with unprogrammed devices, and then program the microcontroller just before shipping the product. This also allows the most recent firmware or a custom firmware to be programmed.

The device is placed into a program/verify mode by holding the RB6 and RB7 pins low while raising the $\overline{\text{MCLR}}$ (V_{PP}) pin from V_{IL} to V_{IH} (see programming specification). RB6 becomes the programming clock and RB7 becomes the programming data. Both RB6 and RB7 are Schmitt Trigger inputs in this mode.

After reset, to place the device into programming/verify mode, the program counter (PC) is at location 00h. A 6-bit command is then supplied to the device. Depending on the command, 14-bits of program data are then supplied to or from the device, depending if the command was a load or a read. For complete details of serial programming, please refer to the PIC16C6X/7X Programming Specifications (Literature #DS30228).

A typical in-circuit serial programming connection is shown in Figure 7-17.

FIGURE 7-17: TYPICAL IN-CIRCUIT SERIAL PROGRAMMING CONNECTION

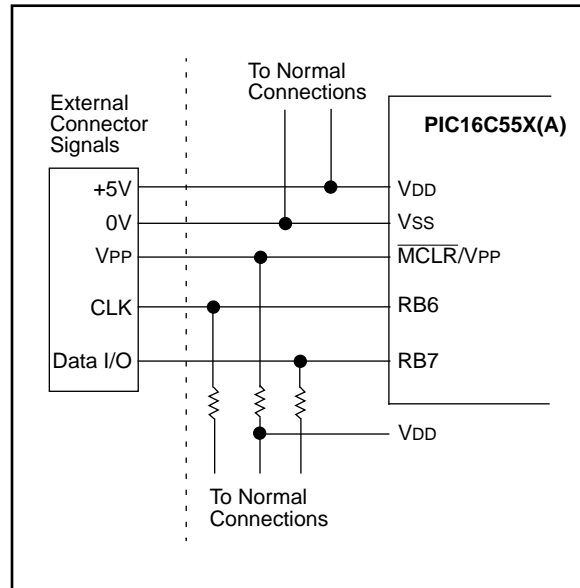

8.0 INSTRUCTION SET SUMMARY

Each PIC16C55X(A) instruction is a 14-bit word divided into an OPCODE which specifies the instruction type and one or more operands which further specify the operation of the instruction. The PIC16C55X(A) instruction set summary in Table 8-2 lists **byte-oriented**, **bit-oriented**, and **literal and control** operations. Table 8-1 shows the opcode field descriptions.

For **byte-oriented** instructions, 'f' represents a file register designator and 'd' represents a destination designator. The file register designator specifies which file register is to be used by the instruction.

The destination designator specifies where the result of the operation is to be placed. If 'd' is zero, the result is placed in the W register. If 'd' is one, the result is placed in the file register specified in the instruction.

For **bit-oriented** instructions, 'b' represents a bit field designator which selects the number of the bit affected by the operation, while 'f' represents the number of the file in which the bit is located.

For **literal and control** operations, 'k' represents an eight or eleven bit constant or literal value.

TABLE 8-1: OPCODE FIELD DESCRIPTIONS

| Field | Description |
|----------------|---|
| f | Register file address (0x00 to 0x7F) |
| w | Working register (accumulator) |
| b | Bit address within an 8-bit file register |
| k | Literal field, constant data or label |
| x | Don't care location (= 0 or 1) The assembler will generate code with x = 0. It is the recommended form of use for compatibility with all Microchip software tools. |
| d | Destination select; d = 0: store result in W, d = 1: store result in file register f. Default is d = 1 |
| label | Label name |
| TOS | Top of Stack |
| PC | Program Counter |
| PCLATH | Program Counter High Latch |
| GIE | Global Interrupt Enable bit |
| WDT | Watchdog Timer/Counter |
| TO | Time-out bit |
| PD | Power-down bit |
| dest | Destination either the W register or the specified register file location |
| [] | Options |
| () | Contents |
| → | Assigned to |
| < > | Register bit field |
| ∈ | In the set of |
| <i>italics</i> | User defined term (font is courier) |

The instruction set is highly orthogonal and is grouped into three basic categories:

- **Byte-oriented** operations
- **Bit-oriented** operations
- **Literal and control** operations

All instructions are executed within one single instruction cycle, unless a conditional test is true or the program counter is changed as a result of an instruction. In this case, the execution takes two instruction cycles with the second cycle executed as a NOP. One instruction cycle consists of four oscillator periods. Thus, for an oscillator frequency of 4 MHz, the normal instruction execution time is 1 μs. If a conditional test is true or the program counter is changed as a result of an instruction, the instruction execution time is 2 μs.

Table 8-1 lists the instructions recognized by the MPASM assembler.

Figure 8-1 shows the three general formats that the instructions can have.

Note: To maintain upward compatibility with future PICmicro™ products, do not use the `OPTION` and `TRIS` instructions.

All examples use the following format to represent a hexadecimal number:

0xhh

where h signifies a hexadecimal digit.

FIGURE 8-1: GENERAL FORMAT FOR INSTRUCTIONS

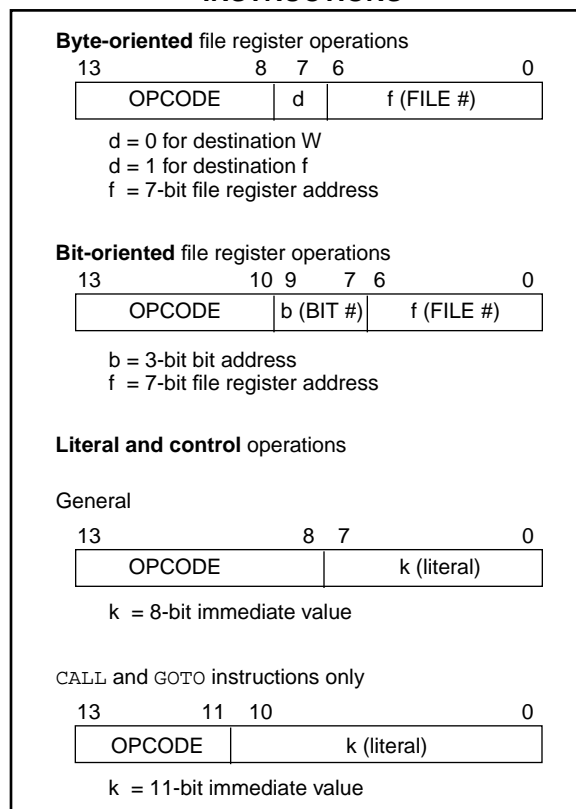

PIC16C55X(A)

TABLE 8-2: PIC16C55X(A) INSTRUCTION SET

| Mnemonic, Operands | Description | Cycles | 14-Bit Opcode | | Status Affected | Notes |
|---|------------------------------|--------|---------------|------|--------------------|--------------------------------|
| | | | MSb | LSb | | |
| BYTE-ORIENTED FILE REGISTER OPERATIONS | | | | | | |
| ADDWF f, d | Add W and f | 1 | 00 | 0111 | dfff ffff | C,DC,Z |
| ANDWF f, d | AND W with f | 1 | 00 | 0101 | dfff ffff | Z |
| CLRF f | Clear f | 1 | 00 | 0001 | 1fff ffff | Z |
| CLRW - | Clear W | 1 | 00 | 0001 | 0xxx xxxx | Z |
| COMF f, d | Complement f | 1 | 00 | 1001 | dfff ffff | Z |
| DECF f, d | Decrement f | 1 | 00 | 0011 | dfff ffff | Z |
| DECFSZ f, d | Decrement f, Skip if 0 | 1(2) | 00 | 1011 | dfff ffff | Z |
| INCF f, d | Increment f | 1 | 00 | 1010 | dfff ffff | Z |
| INCFSZ f, d | Increment f, Skip if 0 | 1(2) | 00 | 1111 | dfff ffff | Z |
| IORWF f, d | Inclusive OR W with f | 1 | 00 | 0100 | dfff ffff | Z |
| MOVF f, d | Move f | 1 | 00 | 1000 | dfff ffff | Z |
| MOVWF f | Move W to f | 1 | 00 | 0000 | 1fff ffff | |
| NOP - | No Operation | 1 | 00 | 0000 | 0xx0 0000 | |
| RLF f, d | Rotate Left f through Carry | 1 | 00 | 1101 | dfff ffff | C |
| RRF f, d | Rotate Right f through Carry | 1 | 00 | 1100 | dfff ffff | C |
| SUBWF f, d | Subtract W from f | 1 | 00 | 0010 | dfff ffff | C,DC,Z |
| SWAPF f, d | Swap nibbles in f | 1 | 00 | 1110 | dfff ffff | Z |
| XORWF f, d | Exclusive OR W with f | 1 | 00 | 0110 | dfff ffff | Z |
| BIT-ORIENTED FILE REGISTER OPERATIONS | | | | | | |
| BCF f, b | Bit Clear f | 1 | 01 | 00bb | bfff ffff | |
| BSF f, b | Bit Set f | 1 | 01 | 01bb | bfff ffff | |
| BTFSC f, b | Bit Test f, Skip if Clear | 1 (2) | 01 | 10bb | bfff ffff | |
| BTFSS f, b | Bit Test f, Skip if Set | 1 (2) | 01 | 11bb | bfff ffff | |
| LITERAL AND CONTROL OPERATIONS | | | | | | |
| ADDLW k | Add literal and W | 1 | 11 | 111x | kkkk kkkk | C,DC,Z |
| ANDLW k | AND literal with W | 1 | 11 | 1001 | kkkk kkkk | Z |
| CALL k | Call subroutine | 2 | 10 | 0kkk | kkkk kkkk | |
| CLRWD\overline{T} - | Clear Watchdog Timer | 1 | 00 | 0000 | 0110 0100 | $\overline{T0}, \overline{PD}$ |
| GOTO k | Go to address | 2 | 10 | 1kkk | kkkk kkkk | |
| IORLW k | Inclusive OR literal with W | 1 | 11 | 1000 | kkkk kkkk | Z |
| MOVLW k | Move literal to W | 1 | 11 | 00xx | kkkk kkkk | |
| RETFIE - | Return from interrupt | 2 | 00 | 0000 | 0000 1001 | |
| RETLW k | Return with literal in W | 2 | 11 | 01xx | kkkk kkkk | |
| RETURN - | Return from Subroutine | 2 | 00 | 0000 | 0000 1000 | |
| SLEEP - | Go into standby mode | 1 | 00 | 0000 | 0110 0011 | $\overline{T0}, \overline{PD}$ |
| SUBLW k | Subtract W from literal | 1 | 11 | 110x | kkkk kkkk | C,DC,Z |
| XORLW k | Exclusive OR literal with W | 1 | 11 | 1010 | kkkk kkkk | Z |

Note 1: When an I/O register is modified as a function of itself (e.g., `MOVF PORTB, 1`), the value used will be that value present on the pins themselves. For example, if the data latch is '1' for a pin configured as input and is driven low by an external device, the data will be written back with a '0'.

2: If this instruction is executed on the TMR0 register (and, where applicable, d = 1), the prescaler will be cleared if assigned to the Timer0 Module.

3: If Program Counter (PC) is modified or a conditional test is true, the instruction requires two cycles. The second cycle is executed as a NOP.

8.1 Instruction Descriptions

| ADDLW | Add Literal and W | | | | |
|------------------|---|------|------|------|------|
| Syntax: | [<i>label</i>] ADDLW k | | | | |
| Operands: | $0 \leq k \leq 255$ | | | | |
| Operation: | $(W) + k \rightarrow (W)$ | | | | |
| Status Affected: | C, DC, Z | | | | |
| Encoding: | <table border="1"><tr><td>11</td><td>111x</td><td>kkkk</td><td>kkkk</td></tr></table> | 11 | 111x | kkkk | kkkk |
| 11 | 111x | kkkk | kkkk | | |
| Description: | The contents of the W register are added to the eight bit literal 'k' and the result is placed in the W register. | | | | |
| Words: | 1 | | | | |
| Cycles: | 1 | | | | |
| Example | ADDLW 0x15 Before Instruction W = 0x10 After Instruction W = 0x25 | | | | |

| ANDLW | AND Literal with W | | | | |
|------------------|---|------|------|------|------|
| Syntax: | [<i>label</i>] ANDLW k | | | | |
| Operands: | $0 \leq k \leq 255$ | | | | |
| Operation: | $(W) .AND. (k) \rightarrow (W)$ | | | | |
| Status Affected: | Z | | | | |
| Encoding: | <table border="1"><tr><td>11</td><td>1001</td><td>kkkk</td><td>kkkk</td></tr></table> | 11 | 1001 | kkkk | kkkk |
| 11 | 1001 | kkkk | kkkk | | |
| Description: | The contents of W register are AND'ed with the eight bit literal 'k'. The result is placed in the W register. | | | | |
| Words: | 1 | | | | |
| Cycles: | 1 | | | | |
| Example | ANDLW 0x5F Before Instruction W = 0xA3 After Instruction W = 0x03 | | | | |

| ADDWF | Add W and f | | | | |
|------------------|--|------|------|------|------|
| Syntax: | [<i>label</i>] ADDWF f,d | | | | |
| Operands: | $0 \leq f \leq 127$ $d \in [0,1]$ | | | | |
| Operation: | $(W) + (f) \rightarrow (dest)$ | | | | |
| Status Affected: | C, DC, Z | | | | |
| Encoding: | <table border="1"><tr><td>00</td><td>0111</td><td>dfff</td><td>ffff</td></tr></table> | 00 | 0111 | dfff | ffff |
| 00 | 0111 | dfff | ffff | | |
| Description: | Add the contents of the W register with register 'f'. If 'd' is 0 the result is stored in the W register. If 'd' is 1 the result is stored back in register 'f'. | | | | |
| Words: | 1 | | | | |
| Cycles: | 1 | | | | |
| Example | ADDWF FSR, 0 Before Instruction W = 0x17 FSR = 0xC2 After Instruction W = 0xD9 FSR = 0xC2 | | | | |

| ANDWF | AND W with f | | | | |
|------------------|--|------|------|------|------|
| Syntax: | [<i>label</i>] ANDWF f,d | | | | |
| Operands: | $0 \leq f \leq 127$ $d \in [0,1]$ | | | | |
| Operation: | $(W) .AND. (f) \rightarrow (dest)$ | | | | |
| Status Affected: | Z | | | | |
| Encoding: | <table border="1"><tr><td>00</td><td>0101</td><td>dfff</td><td>ffff</td></tr></table> | 00 | 0101 | dfff | ffff |
| 00 | 0101 | dfff | ffff | | |
| Description: | AND the W register with register 'f'. If 'd' is 0 the result is stored in the W register. If 'd' is 1 the result is stored back in register 'f'. | | | | |
| Words: | 1 | | | | |
| Cycles: | 1 | | | | |
| Example | ANDWF FSR, 1 Before Instruction W = 0x17 FSR = 0xC2 After Instruction W = 0x17 FSR = 0x02 | | | | |

PIC16C55X(A)

BCF Bit Clear f

Syntax: [*label*] BCF f,b
Operands: $0 \leq f \leq 127$
 $0 \leq b \leq 7$
Operation: $0 \rightarrow (f)$
Status Affected: None
Encoding:

| | | | |
|----|------|------|------|
| 01 | 00bb | bfff | ffff |
|----|------|------|------|

Description: Bit 'b' in register 'f' is cleared.
Words: 1
Cycles: 1
Example `BCF FLAG_REG, 7`

Before Instruction
FLAG_REG = 0xC7
After Instruction
FLAG_REG = 0x47

BTFSC Bit Test, Skip if Clear

Syntax: [*label*] BTFSC f,b
Operands: $0 \leq f \leq 127$
 $0 \leq b \leq 7$
Operation: skip if (f) = 0
Status Affected: None
Encoding:

| | | | |
|----|------|------|------|
| 01 | 10bb | bfff | ffff |
|----|------|------|------|

Description: If bit 'b' in register 'f' is '0' then the next instruction is skipped.
If bit 'b' is '0' then the next instruction fetched during the current instruction execution is discarded, and a NOP is executed instead, making this a two-cycle instruction.
Words: 1
Cycles: 1(2)
Example `HERE BTFSC FLAG,1`
`FALSE GOTO PROCESS_CODE`
`TRUE`
`•`
`•`
`•`

Before Instruction
PC = address HERE
After Instruction
if FLAG<1> = 0,
PC = address TRUE
if FLAG<1> = 1,
PC = address FALSE

BSF Bit Set f

Syntax: [*label*] BSF f,b
Operands: $0 \leq f \leq 127$
 $0 \leq b \leq 7$
Operation: $1 \rightarrow (f)$
Status Affected: None
Encoding:

| | | | |
|----|------|------|------|
| 01 | 01bb | bfff | ffff |
|----|------|------|------|

Description: Bit 'b' in register 'f' is set.
Words: 1
Cycles: 1
Example `BSF FLAG_REG, 7`

Before Instruction
FLAG_REG = 0x0A
After Instruction
FLAG_REG = 0x8A

BTFSS **Bit Test f, Skip if Set**

Syntax: [*label*] BTFSS *f*,*b*

Operands: $0 \leq f \leq 127$
 $0 \leq b < 7$

Operation: skip if (*f*<*b*>) = 1

Status Affected: None

Encoding:

| | | | |
|----|------|------|------|
| 01 | 11bb | bfff | ffff |
|----|------|------|------|

Description: If bit 'b' in register 'f' is '1' then the next instruction is skipped.
 If bit 'b' is '0', then the next instruction fetched during the current instruction execution, is discarded and a NOP is executed instead, making this a two-cycle instruction.

Words: 1

Cycles: 1(2)

Example

```

HERE   BTFSC  FLAG,1
FALSE  GOTO   PROCESS_CODE
TRUE   .
      .
      .
  
```

Before Instruction
 PC = address HERE

After Instruction
 if FLAG<1> = 0,
 PC = address FALSE
 if FLAG<1> = 1,
 PC = address TRUE

CALL **Call Subroutine**

Syntax: [*label*] CALL *k*

Operands: $0 \leq k \leq 2047$

Operation: (*PC*)+ 1 → TOS,
 $k \rightarrow PC<10:0>$,
 (*PCLATH*<4:3>) → *PC*<12:11>

Status Affected: None

Encoding:

| | | | |
|----|------|------|------|
| 10 | 0kkk | kkkk | kkkk |
|----|------|------|------|

Description: Call Subroutine. First, return address (*PC*+1) is pushed onto the stack. The eleven bit immediate address is loaded into *PC* bits <10:0>. The upper bits of the *PC* are loaded from *PCLATH*. *CALL* is a two-cycle instruction.

Words: 1

Cycles: 2

Example

```

HERE   CALL  THERE
  
```

Before Instruction
 PC = Address HERE

After Instruction
 PC = Address THERE
 TOS = Address HERE+1

CLRF **Clear f**

Syntax: [*label*] CLRF *f*

Operands: $0 \leq f \leq 127$

Operation: 00h → (*f*)
 1 → Z

Status Affected: Z

Encoding:

| | | | |
|----|------|------|------|
| 00 | 0001 | 1fff | ffff |
|----|------|------|------|

Description: The contents of register 'f' are cleared and the Z bit is set.

Words: 1

Cycles: 1

Example

```

CLRF   FLAG_REG
  
```

Before Instruction
 FLAG_REG = 0x5A

After Instruction
 FLAG_REG = 0x00
 Z = 1

CLRW **Clear W**

Syntax: [*label*] CLRW

Operands: None

Operation: 00h → (*W*)
 1 → Z

Status Affected: Z

Encoding:

| | | | |
|----|------|------|------|
| 00 | 0001 | 0xxx | xxxx |
|----|------|------|------|

Description: W register is cleared. Zero bit (Z) is set.

Words: 1

Cycles: 1

Example

```

CLRW
  
```

Before Instruction
 W = 0x5A

After Instruction
 W = 0x00
 Z = 1

PIC16C55X(A)

CLRWDT **Clear Watchdog Timer**

Syntax: [*label*] CLRWDT

Operands: None

Operation: 00h → WDT
0 → WDT prescaler,
1 → \overline{TO}
1 → \overline{PD}

Status Affected: \overline{TO} , \overline{PD}

| | | | | |
|-----------|----|------|------|------|
| Encoding: | 00 | 0000 | 0110 | 0100 |
|-----------|----|------|------|------|

Description: CLRWDT instruction resets the Watchdog Timer. It also resets the prescaler of the WDT. Status bits \overline{TO} and \overline{PD} are set.

Words: 1

Cycles: 1

Example

```
CLRWDT
```

Before Instruction

```
WDT counter = ?
```

After Instruction

```
WDT counter = 0x00
WDT prescaler = 0
 $\overline{TO}$  = 1
 $\overline{PD}$  = 1
```

COMF **Complement f**

Syntax: [*label*] COMF f,d

Operands: $0 \leq f \leq 127$
 $d \in [0,1]$

Operation: (\bar{f}) → (dest)

Status Affected: Z

| | | | | |
|-----------|----|------|------|------|
| Encoding: | 00 | 1001 | dfff | ffff |
|-----------|----|------|------|------|

Description: The contents of register 'f' are complemented. If 'd' is 0 the result is stored in W. If 'd' is 1 the result is stored back in register 'f'.

Words: 1

Cycles: 1

Example

```
COMF    REG1, 0
```

Before Instruction

```
REG1 = 0x13
```

After Instruction

```
REG1 = 0x13
W = 0xEC
```

DECf **Decrement f**

Syntax: [*label*] DECf f,d

Operands: $0 \leq f \leq 127$
 $d \in [0,1]$

Operation: (f) - 1 → (dest)

Status Affected: Z

| | | | | |
|-----------|----|------|------|------|
| Encoding: | 00 | 0011 | dfff | ffff |
|-----------|----|------|------|------|

Description: Decrement register 'f'. If 'd' is 0 the result is stored in the W register. If 'd' is 1 the result is stored back in register 'f'.

Words: 1

Cycles: 1

Example

```
DECf    CNT, 1
```

Before Instruction

```
CNT = 0x01
Z = 0
```

After Instruction

```
CNT = 0x00
Z = 1
```

DECFSZ **Decrement f, Skip if 0**

Syntax: [*label*] DECFSZ f,d

Operands: $0 \leq f \leq 127$
 $d \in [0,1]$

Operation: (f) - 1 → (dest); skip if result = 0

Status Affected: None

| | | | | |
|-----------|----|------|------|------|
| Encoding: | 00 | 1011 | dfff | ffff |
|-----------|----|------|------|------|

Description: The contents of register 'f' are decremented. If 'd' is 0 the result is placed in the W register. If 'd' is 1 the result is placed back in register 'f'. If the result is 0, the next instruction, which is already fetched, is discarded. A NOP is executed instead making it a two-cycle instruction.

Words: 1

Cycles: 1(2)

Example

```
HERE    DECFSZ CNT, 1
        GOTO    LOOP
CONTINUE •
        •
        •
```

Before Instruction

```
PC = address HERE
```

After Instruction

```
CNT = CNT - 1
if CNT = 0,
PC = address CONTINUE
if CNT ≠ 0,
PC = address HERE+1
```

GOTO **Unconditional Branch**

Syntax: `[label] GOTO k`

Operands: $0 \leq k \leq 2047$

Operation: $k \rightarrow PC<10:0>$
 $PCLATH<4:3> \rightarrow PC<12:11>$

Status Affected: None

Encoding:

| | | | |
|----|------|------|------|
| 10 | 1kkk | kkkk | kkkk |
|----|------|------|------|

Description: GOTO is an unconditional branch. The eleven bit immediate value is loaded into PC bits <10:0>. The upper bits of PC are loaded from PCLATH<4:3>. GOTO is a two-cycle instruction.

Words: 1

Cycles: 2

Example `GOTO THERE`
 After Instruction
 `PC = Address THERE`

INCFSZ **Increment f, Skip if 0**

Syntax: `[label] INCFSZ f,d`

Operands: $0 \leq f \leq 127$
 $d \in [0,1]$

Operation: $(f) + 1 \rightarrow (\text{dest})$, skip if result = 0

Status Affected: None

Encoding:

| | | | |
|----|------|------|------|
| 00 | 1111 | dfff | ffff |
|----|------|------|------|

Description: The contents of register 'f' are incremented. If 'd' is 0 the result is placed in the W register. If 'd' is 1 the result is placed back in register 'f'. If the result is 0, the next instruction, which is already fetched, is discarded. A NOP is executed instead making it a two-cycle instruction.

Words: 1

Cycles: 1(2)

Example `HERE INCFSZ CNT, 1`
 `GOTO LOOP`
 `CONTINUE •`
 `•`
 `•`

Before Instruction
`PC = address HERE`

After Instruction
`CNT = CNT + 1`
 if CNT= 0,
`PC = address CONTINUE`
 if CNT≠ 0,
`PC = address HERE +1`

INCF **Increment f**

Syntax: `[label] INCF f,d`

Operands: $0 \leq f \leq 127$
 $d \in [0,1]$

Operation: $(f) + 1 \rightarrow (\text{dest})$

Status Affected: Z

Encoding:

| | | | |
|----|------|------|------|
| 00 | 1010 | dfff | ffff |
|----|------|------|------|

Description: The contents of register 'f' are incremented. If 'd' is 0 the result is placed in the W register. If 'd' is 1 the result is placed back in register 'f'.

Words: 1

Cycles: 1

Example `INCF CNT, 1`
 Before Instruction
 `CNT = 0xFF`
 `Z = 0`
 After Instruction
 `CNT = 0x00`
 `Z = 1`

IORLW **Inclusive OR Literal with W**

Syntax: `[label] IORLW k`

Operands: $0 \leq k \leq 255$

Operation: $(W) .OR. k \rightarrow (W)$

Status Affected: Z

Encoding:

| | | | |
|----|------|------|------|
| 11 | 1000 | kkkk | kkkk |
|----|------|------|------|

Description: The contents of the W register is OR'ed with the eight bit literal 'k'. The result is placed in the W register.

Words: 1

Cycles: 1

Example `IORLW 0x35`
 Before Instruction
 `W = 0x9A`
 After Instruction
 `W = 0xBF`
 `Z = 1`

PIC16C55X(A)

IORWF Inclusive OR W with f

Syntax: [*label*] IORWF *f*,*d*
 Operands: $0 \leq f \leq 127$
 $d \in [0,1]$
 Operation: (W) .OR. (f) → (dest)
 Status Affected: Z
 Encoding:

| | | | |
|----|------|------|------|
| 00 | 0100 | dfff | ffff |
|----|------|------|------|

 Description: Inclusive OR the W register with register 'f'. If 'd' is 0 the result is placed in the W register. If 'd' is 1 the result is placed back in register 'f'.
 Words: 1
 Cycles: 1
 Example `IORWF RESULT, 0`

Before Instruction
 RESULT = 0x13
 W = 0x91
 After Instruction
 RESULT = 0x13
 W = 0x93
 Z = 1

MOVF Move f

Syntax: [*label*] MOVF *f*,*d*
 Operands: $0 \leq f \leq 127$
 $d \in [0,1]$
 Operation: (f) → (dest)
 Status Affected: Z
 Encoding:

| | | | |
|----|------|------|------|
| 00 | 1000 | dfff | ffff |
|----|------|------|------|

 Description: The contents of register f is moved to a destination dependant upon the status of d. If d = 0, destination is W register. If d = 1, the destination is file register f itself. d = 1 is useful to test a file register since status flag Z is affected.
 Words: 1
 Cycles: 1
 Example `MOVF FSR, 0`

After Instruction
 W = value in FSR register
 Z = 1

MOVLW Move Literal to W

Syntax: [*label*] MOVLW *k*
 Operands: $0 \leq k \leq 255$
 Operation: *k* → (W)
 Status Affected: None
 Encoding:

| | | | |
|----|------|------|------|
| 11 | 00xx | kkkk | kkkk |
|----|------|------|------|

 Description: The eight bit literal 'k' is loaded into W register. The don't cares will assemble as 0's.
 Words: 1
 Cycles: 1
 Example `MOVLW 0x5A`

After Instruction
 W = 0x5A

MOVWF Move W to f

Syntax: [*label*] MOVWF *f*
 Operands: $0 \leq f \leq 127$
 Operation: (W) → (f)
 Status Affected: None
 Encoding:

| | | | |
|----|------|------|------|
| 00 | 0000 | 1fff | ffff |
|----|------|------|------|

 Description: Move data from W register to register 'f'.
 Words: 1
 Cycles: 1
 Example `MOVWF OPTION`

Before Instruction
 OPTION = 0xFF
 W = 0x4F
 After Instruction
 OPTION = 0x4F
 W = 0x4F

| NOP | No Operation | | | | |
|------------------|---|-------|------|-------|------|
| Syntax: | [<i>label</i>] NOP | | | | |
| Operands: | None | | | | |
| Operation: | No operation | | | | |
| Status Affected: | None | | | | |
| Encoding: | <table border="1"> <tr> <td>00</td> <td>0000</td> <td>0xxx0</td> <td>0000</td> </tr> </table> | 00 | 0000 | 0xxx0 | 0000 |
| 00 | 0000 | 0xxx0 | 0000 | | |
| Description: | No operation. | | | | |
| Words: | 1 | | | | |
| Cycles: | 1 | | | | |
| Example | NOP | | | | |

| RETFIE | Return from Interrupt | | | | |
|------------------|--|------|------|------|------|
| Syntax: | [<i>label</i>] RETFIE | | | | |
| Operands: | None | | | | |
| Operation: | TOS → PC, 1 → GIE | | | | |
| Status Affected: | None | | | | |
| Encoding: | <table border="1"> <tr> <td>00</td> <td>0000</td> <td>0000</td> <td>1001</td> </tr> </table> | 00 | 0000 | 0000 | 1001 |
| 00 | 0000 | 0000 | 1001 | | |
| Description: | Return from Interrupt. Stack is POPed and Top of Stack (TOS) is loaded in the PC. Interrupts are enabled by setting Global Interrupt Enable bit, GIE (INTCON<7>). This is a two-cycle instruction. | | | | |
| Words: | 1 | | | | |
| Cycles: | 2 | | | | |
| Example | <pre>RETFIE After Interrupt PC = TOS GIE = 1</pre> | | | | |

| OPTION | Load Option Register | | | | |
|------------------|--|------|------|------|------|
| Syntax: | [<i>label</i>] OPTION | | | | |
| Operands: | None | | | | |
| Operation: | (W) → OPTION | | | | |
| Status Affected: | None | | | | |
| Encoding: | <table border="1"> <tr> <td>00</td> <td>0000</td> <td>0110</td> <td>0010</td> </tr> </table> | 00 | 0000 | 0110 | 0010 |
| 00 | 0000 | 0110 | 0010 | | |
| Description: | The contents of the W register are loaded in the OPTION register. This instruction is supported for code compatibility with PIC16C5X products. Since OPTION is a readable/writable register, the user can directly address it. | | | | |
| Words: | 1 | | | | |
| Cycles: | 1 | | | | |
| Example | <div style="border: 1px solid black; padding: 5px; width: fit-content; margin: 0 auto;"> <p>To maintain upward compatibility with future PICmicro™ products, do not use this instruction.</p> </div> | | | | |

| RETLW | Return with Literal in W | | | | |
|------------------|--|------|------|------|------|
| Syntax: | [<i>label</i>] RETLW k | | | | |
| Operands: | 0 ≤ k ≤ 255 | | | | |
| Operation: | k → (W); TOS → PC | | | | |
| Status Affected: | None | | | | |
| Encoding: | <table border="1"> <tr> <td>11</td> <td>01xx</td> <td>kkkk</td> <td>kkkk</td> </tr> </table> | 11 | 01xx | kkkk | kkkk |
| 11 | 01xx | kkkk | kkkk | | |
| Description: | The W register is loaded with the eight bit literal 'k'. The program counter is loaded from the top of the stack (the return address). This is a two-cycle instruction. | | | | |
| Words: | 1 | | | | |
| Cycles: | 2 | | | | |
| Example | <pre>CALL TABLE ;W contains table ;offset value ;W now has table . value . TABLE ADDWF PC ;W = offset RETLW k1 ;Begin table RETLW k2 ; . . RETLW kn ; End of table</pre> <p>Before Instruction W = 0x07</p> <p>After Instruction W = value of k8</p> | | | | |

PIC16C55X(A)

RETURN Return from Subroutine

Syntax: [label] RETURN

Operands: None

Operation: TOS → PC

Status Affected: None

Encoding:

| | | | |
|----|------|------|------|
| 00 | 0000 | 0000 | 1000 |
|----|------|------|------|

Description: Return from subroutine. The stack is POPed and the top of the stack (TOS) is loaded into the program counter. This is a two cycle instruction.

Words: 1

Cycles: 2

Example: RETURN

After Interrupt
PC = TOS

RRF Rotate Right f through Carry

Syntax: [label] RRF f,d

Operands: $0 \leq f \leq 127$
 $d \in [0,1]$

Operation: See description below

Status Affected: C

Encoding:

| | | | |
|----|------|------|------|
| 00 | 1100 | dfff | ffff |
|----|------|------|------|

Description: The contents of register 'f' are rotated one bit to the right through the Carry Flag. If 'd' is 0 the result is placed in the W register. If 'd' is 1 the result is placed back in register 'f'.

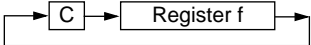

Words: 1

Cycles: 1

Example: RRF REG1,0

Before Instruction
REG1 = 1110 0110
C = 0

After Instruction
REG1 = 1110 0110
W = 0111 0011
C = 0

RLF Rotate Left f through Carry

Syntax: [label] RLF f,d

Operands: $0 \leq f \leq 127$
 $d \in [0,1]$

Operation: See description below

Status Affected: C

Encoding:

| | | | |
|----|------|------|------|
| 00 | 1101 | dfff | ffff |
|----|------|------|------|

Description: The contents of register 'f' are rotated one bit to the left through the Carry Flag. If 'd' is 0 the result is placed in the W register. If 'd' is 1 the result is stored back in register 'f'.

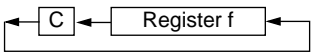

Words: 1

Cycles: 1

Example: RLF REG1,0

Before Instruction
REG1 = 1110 0110
C = 0

After Instruction
REG1 = 1110 0110
W = 1100 1100
C = 1

SLEEP

Syntax: [label] SLEEP

Operands: None

Operation: 00h → WDT,
0 → WDT prescaler,
1 → \overline{TO} ,
0 → \overline{PD}

Status Affected: \overline{TO} , \overline{PD}

Encoding:

| | | | |
|----|------|------|------|
| 00 | 0000 | 0110 | 0011 |
|----|------|------|------|

Description: The power-down status bit, \overline{PD} is cleared. Time-out status bit, \overline{TO} is set. Watchdog Timer and its prescaler are cleared. The processor is put into SLEEP mode with the oscillator stopped. See Section 7.8 for more details.

Words: 1

Cycles: 1

Example: SLEEP

SUBLW **Subtract W from Literal**

Syntax: [*label*] SUBLW k
 Operands: $0 \leq k \leq 255$
 Operation: $k - (W) \rightarrow (W)$
 Status
 Affected: C, DC, Z
 Encoding:

| | | | |
|----|------|------|------|
| 11 | 110x | kkkk | kkkk |
|----|------|------|------|

Description: The W register is subtracted (2's complement method) from the eight bit literal 'k'. The result is placed in the W register.

Words: 1

Cycles: 1

Example 1: SUBLW 0x02

Before Instruction

W = 1
C = ?

After Instruction

W = 1
C = 1; result is positive

Example 2: Before Instruction

W = 2
C = ?

After Instruction

W = 0
C = 1; result is zero

Example 3: Before Instruction

W = 3
C = ?

After Instruction

W = 0xFF
C = 0; result is negative

SUBWF **Subtract W from f**

Syntax: [*label*] SUBWF f,d
 Operands: $0 \leq f \leq 127$
 $d \in [0,1]$
 Operation: $(f) - (W) \rightarrow (\text{dest})$
 Status
 Affected: C, DC, Z
 Encoding:

| | | | |
|----|------|------|------|
| 00 | 0010 | dfff | ffff |
|----|------|------|------|

Description: Subtract (2's complement method) W register from register 'f'. If 'd' is 0 the result is stored in the W register. If 'd' is 1 the result is stored back in register 'f'.

Words: 1

Cycles: 1

Example 1: SUBWF REG1, 1

Before Instruction

REG1 = 3
W = 2
C = ?

After Instruction

REG1 = 1
W = 2
C = 1; result is positive

Example 2: Before Instruction

REG1 = 2
W = 2
C = ?

After Instruction

REG1 = 0
W = 2
C = 1; result is zero

Example 3: Before Instruction

REG1 = 1
W = 2
C = ?

After Instruction

REG1 = 0xFF
W = 2
C = 0; result is negative

PIC16C55X(A)

| SWAPF | Swap Nibbles in f | | | | |
|------------------|--|------|------|------|------|
| Syntax: | [<i>label</i>] SWAPF f,d | | | | |
| Operands: | 0 ≤ f ≤ 127 d ∈ [0,1] | | | | |
| Operation: | (f<3:0>) → (dest<7:4>), (f<7:4>) → (dest<3:0>) | | | | |
| Status Affected: | None | | | | |
| Encoding: | <table border="1"> <tr> <td>00</td> <td>1110</td> <td>dfff</td> <td>ffff</td> </tr> </table> | 00 | 1110 | dfff | ffff |
| 00 | 1110 | dfff | ffff | | |
| Description: | The upper and lower nibbles of register 'f' are exchanged. If 'd' is 0 the result is placed in W register. If 'd' is 1 the result is placed in register 'f'. | | | | |
| Words: | 1 | | | | |
| Cycles: | 1 | | | | |
| Example | SWAPF REG, 0 Before Instruction REG1 = 0xA5 After Instruction REG1 = 0xA5 W = 0x5A | | | | |

| TRIS | Load TRIS Register | | | | |
|------------------|---|------|------|------|------|
| Syntax: | [<i>label</i>] TRIS f | | | | |
| Operands: | 5 ≤ f ≤ 7 | | | | |
| Operation: | (W) → TRIS register f; | | | | |
| Status Affected: | None | | | | |
| Encoding: | <table border="1"> <tr> <td>00</td> <td>0000</td> <td>0110</td> <td>0fff</td> </tr> </table> | 00 | 0000 | 0110 | 0fff |
| 00 | 0000 | 0110 | 0fff | | |
| Description: | The instruction is supported for code compatibility with the PIC16C5X products. Since TRIS registers are readable and writable, the user can directly address them. | | | | |
| Words: | 1 | | | | |
| Cycles: | 1 | | | | |
| Example | To maintain upward compatibility with future PICmicro™ products, do not use this instruction. | | | | |

| XORLW | Exclusive OR Literal with W | | | | |
|------------------|---|------|------|------|------|
| Syntax: | [<i>label</i>] XORLW k | | | | |
| Operands: | 0 ≤ k ≤ 255 | | | | |
| Operation: | (W) .XOR. k → (W) | | | | |
| Status Affected: | Z | | | | |
| Encoding: | <table border="1"> <tr> <td>11</td> <td>1010</td> <td>kkkk</td> <td>kkkk</td> </tr> </table> | 11 | 1010 | kkkk | kkkk |
| 11 | 1010 | kkkk | kkkk | | |
| Description: | The contents of the W register are XOR'ed with the eight bit literal 'k'. The result is placed in the W register. | | | | |
| Words: | 1 | | | | |
| Cycles: | 1 | | | | |
| Example: | XORLW 0xAF Before Instruction W = 0xB5 After Instruction W = 0x1A | | | | |

| XORWF | Exclusive OR W with f | | | | |
|------------------|---|------|------|------|------|
| Syntax: | [<i>label</i>] XORWF f,d | | | | |
| Operands: | 0 ≤ f ≤ 127 d ∈ [0,1] | | | | |
| Operation: | (W) .XOR. (f) → (dest) | | | | |
| Status Affected: | Z | | | | |
| Encoding: | <table border="1"> <tr> <td>00</td> <td>0110</td> <td>dfff</td> <td>ffff</td> </tr> </table> | 00 | 0110 | dfff | ffff |
| 00 | 0110 | dfff | ffff | | |
| Description: | Exclusive OR the contents of the W register with register 'f'. If 'd' is 0 the result is stored in the W register. If 'd' is 1 the result is stored back in register 'f'. | | | | |
| Words: | 1 | | | | |
| Cycles: | 1 | | | | |
| Example | XORWF REG 1 Before Instruction REG = 0xAF W = 0xB5 After Instruction REG = 0x1A W = 0xB5 | | | | |

9.0 DEVELOPMENT SUPPORT

9.1 Development Tools

The PICmicro™ microcontrollers are supported with a full range of hardware and software development tools:

- PICMASTER/DS40143BICMASTER CE Real-Time In-Circuit Emulator
- ICEPIC Low-Cost PIC16C5X and PIC16CXXX In-Circuit Emulator
- PRO MATE® II Universal Programmer
- PICSTART® Plus Entry-Level Prototype Programmer
- PICDEM-1 Low-Cost Demonstration Board
- PICDEM-2 Low-Cost Demonstration Board
- PICDEM-3 Low-Cost Demonstration Board
- MPASM Assembler
- MPLAB™ SIM Software Simulator
- MPLAB-C (C Compiler)
- Fuzzy Logic Development System (*fuzzyTECH*®-MP)

9.2 PICMASTER: High Performance Universal In-Circuit Emulator with MPLAB IDE

The PICMASTER Universal In-Circuit Emulator is intended to provide the product development engineer with a complete microcontroller design tool set for all microcontrollers in the SX, PIC14C000, PIC16C5X, PIC16CXXX and PIC17CXX families. PICMASTER is supplied with the MPLAB™ Integrated Development Environment (IDE), which allows editing, “make” and download, and source debugging from a single environment.

Interchangeable target probes allow the system to be easily reconfigured for emulation of different processors. The universal architecture of the PICMASTER allows expansion to support all new Microchip microcontrollers.

The PICMASTER Emulator System has been designed as a real-time emulation system with advanced features that are generally found on more expensive development tools. The PC compatible 386 (and higher) machine platform and Microsoft Windows® 3.x environment were chosen to best make these features available to you, the end user.

A CE compliant version of PICMASTER is available for European Union (EU) countries.

9.3 ICEPIC: Low-Cost PICmicro™ In-Circuit Emulator

ICEPIC is a low-cost in-circuit emulator solution for the Microchip PIC12CXXX, PIC16C5X and PIC16CXXX families of 8-bit OTP microcontrollers.

ICEPIC is designed to operate on PC-compatible machines ranging from 286-AT® through Pentium™ based machines under Windows 3.x environment. ICEPIC features real time, non-intrusive emulation.

9.4 PRO MATE II: Universal Programmer

The PRO MATE II Universal Programmer is a full-featured programmer capable of operating in stand-alone mode as well as PC-hosted mode.

The PRO MATE II has programmable VDD and VPP supplies which allows it to verify programmed memory at VDD min and VDD max for maximum reliability. It has an LCD display for displaying error messages, keys to enter commands and a modular detachable socket assembly to support various package types. In stand-alone mode the PRO MATE II can read, verify or program PIC12CXXX, PIC14C000, PIC16C5X, PIC16CXXX and PIC17CXX devices. It can also set configuration and code-protect bits in this mode.

9.5 PICSTART Plus Entry Level Development System

The PICSTART programmer is an easy-to-use, low-cost prototype programmer. It connects to the PC via one of the COM (RS-232) ports. MPLAB Integrated Development Environment software makes using the programmer simple and efficient. PICSTART Plus is not recommended for production programming.

PICSTART Plus supports all PIC12CXXX, PIC14C000, PIC16C5X, PIC16CXXX and PIC17CXX devices with up to 40 pins. Larger pin count devices such as the PIC16C923 and PIC16C924 may be supported with an adapter socket.

PIC16C55X(A)

9.6 PICDEM-1 Low-Cost PICmicro Demonstration Board

The PICDEM-1 is a simple board which demonstrates the capabilities of several of Microchip's microcontrollers. The microcontrollers supported are: PIC16C5X (PIC16C54 to PIC16C58A), PIC16C61, PIC16C62X, PIC16C71, PIC16C8X, PIC17C42, PIC17C43 and PIC17C44. All necessary hardware and software is included to run basic demo programs. The users can program the sample microcontrollers provided with the PICDEM-1 board, on a PRO MATE II or PICSTART-Plus programmer, and easily test firmware. The user can also connect the PICDEM-1 board to the PICMASTER emulator and download the firmware to the emulator for testing. Additional prototype area is available for the user to build some additional hardware and connect it to the microcontroller socket(s). Some of the features include an RS-232 interface, a potentiometer for simulated analog input, push-button switches and eight LEDs connected to PORTB.

9.7 PICDEM-2 Low-Cost PIC16CXX Demonstration Board

The PICDEM-2 is a simple demonstration board that supports the PIC16C62, PIC16C64, PIC16C65, PIC16C73 and PIC16C74 microcontrollers. All the necessary hardware and software is included to run the basic demonstration programs. The user can program the sample microcontrollers provided with the PICDEM-2 board, on a PRO MATE II programmer or PICSTART-Plus, and easily test firmware. The PICMASTER emulator may also be used with the PICDEM-2 board to test firmware. Additional prototype area has been provided to the user for adding additional hardware and connecting it to the microcontroller socket(s). Some of the features include a RS-232 interface, push-button switches, a potentiometer for simulated analog input, a Serial EEPROM to demonstrate usage of the I²C bus and separate headers for connection to an LCD module and a keypad.

9.8 PICDEM-3 Low-Cost PIC16CXXX Demonstration Board

The PICDEM-3 is a simple demonstration board that supports the PIC16C923 and PIC16C924 in the PLCC package. It will also support future 44-pin PLCC microcontrollers with a LCD Module. All the necessary hardware and software is included to run the basic demonstration programs. The user can program the sample microcontrollers provided with the PICDEM-3 board, on a PRO MATE II programmer or PICSTART Plus with an adapter socket, and easily test firmware. The PICMASTER emulator may also be used with the PICDEM-3 board to test firmware. Additional prototype area has been provided to the user for adding hardware and connecting it to the microcontroller socket(s). Some of the features include

an RS-232 interface, push-button switches, a potentiometer for simulated analog input, a thermistor and separate headers for connection to an external LCD module and a keypad. Also provided on the PICDEM-3 board is an LCD panel, with 4 commons and 12 segments, that is capable of displaying time, temperature and day of the week. The PICDEM-3 provides an additional RS-232 interface and Windows 3.1 software for showing the demultiplexed LCD signals on a PC. A simple serial interface allows the user to construct a hardware demultiplexer for the LCD signals.

9.9 MPLAB™ Integrated Development Environment Software

The MPLAB IDE Software brings an ease of software development previously unseen in the 8-bit microcontroller market. MPLAB is a windows based application which contains:

- A full featured editor
- Three operating modes
 - editor
 - emulator
 - simulator
- A project manager
- Customizable tool bar and key mapping
- A status bar with project information
- Extensive on-line help

MPLAB allows you to:

- Edit your source files (either assembly or 'C')
- One touch assemble (or compile) and download to PICmicro tools (automatically updates all project information)
- Debug using:
 - source files
 - absolute listing file
- Transfer data dynamically via DDE (soon to be replaced by OLE)
- Run up to four emulators on the same PC

The ability to use MPLAB with Microchip's simulator allows a consistent platform and the ability to easily switch from the low cost simulator to the full featured emulator with minimal retraining due to development tools.

9.10 Assembler (MPASM)

The MPASM Universal Macro Assembler is a PC-hosted symbolic assembler. It supports all microcontroller series including the PIC12C5XX, PIC14000, PIC16C5X, PIC16CXXX, and PIC17CXX families.

MPASM offers full featured Macro capabilities, conditional assembly, and several source and listing formats. It generates various object code formats to support Microchip's development tools as well as third party programmers.

MPASM allows full symbolic debugging from PICMASTER, Microchip's Universal Emulator System.

MPASM has the following features to assist in developing software for specific use applications.

- Provides translation of Assembler source code to object code for all Microchip microcontrollers.
- Macro assembly capability.
- Produces all the files (Object, Listing, Symbol, and special) required for symbolic debug with Microchip's emulator systems.
- Supports Hex (default), Decimal and Octal source and listing formats.

MPASM provides a rich directive language to support programming of the PICmicro. Directives are helpful in making the development of your assemble source code shorter and more maintainable.

9.11 Software Simulator (MPLAB-SIM)

The MPLAB-SIM Software Simulator allows code development in a PC host environment. It allows the user to simulate the PICmicro series microcontrollers on an instruction level. On any given instruction, the user may examine or modify any of the data areas or provide external stimulus to any of the pins. The input/output radix can be set by the user and the execution can be performed in; single step, execute until break, or in a trace mode.

MPLAB-SIM fully supports symbolic debugging using MPLAB-C and MPASM. The Software Simulator offers the low cost flexibility to develop and debug code outside of the laboratory environment making it an excellent multi-project software development tool.

9.12 C Compiler (MPLAB-C)

The MPLAB-C Code Development System is a complete 'C' compiler and integrated development environment for Microchip's PICmicro™ family of microcontrollers. The compiler provides powerful integration capabilities and ease of use not found with other compilers.

For easier source level debugging, the compiler provides symbol information that is compatible with the MPLAB IDE memory display.

9.13 Fuzzy Logic Development System (fuzzyTECH-MP)

fuzzyTECH-MP fuzzy logic development tool is available in two versions - a low cost introductory version, MP Explorer, for designers to gain a comprehensive working knowledge of fuzzy logic system design; and a full-featured version, *fuzzyTECH-MP*, edition for implementing more complex systems.

Both versions include Microchip's *fuzzyLAB™* demonstration board for hands-on experience with fuzzy logic systems implementation.

9.14 MP-DriveWay™ – Application Code Generator

MP-DriveWay is an easy-to-use Windows-based Application Code Generator. With MP-DriveWay you can visually configure all the peripherals in a PICmicro device and, with a click of the mouse, generate all the initialization and many functional code modules in C language. The output is fully compatible with Microchip's MPLAB-C C compiler. The code produced is highly modular and allows easy integration of your own code. MP-DriveWay is intelligent enough to maintain your code through subsequent code generation.

9.15 SEEVAL® Evaluation and Programming System

The SEEVAL SEEPROM Designer's Kit supports all Microchip 2-wire and 3-wire Serial EEPROMs. The kit includes everything necessary to read, write, erase or program special features of any Microchip SEEPROM product including Smart Serials™ and secure serials. The Total Endurance™ Disk is included to aid in trade-off analysis and reliability calculations. The total kit can significantly reduce time-to-market and result in an optimized system.

9.16 KEELOQ® Evaluation and Programming Tools

KEELOQ evaluation and programming tools support Microchips HCS Secure Data Products. The HCS evaluation kit includes an LCD display to show changing codes, a decoder to decode transmissions, and a programming interface to program test transmitters.

PIC16C55X(A)

TABLE 9-1: DEVELOPMENT TOOLS FROM MICROCHIP

| | PIC12C5XX | PIC14000 | PIC16C5X | PIC16CXXX | PIC16C6X | PIC16C7XX | PIC16C8X | PIC16C9XX | PIC17C4X | PIC17C75X | 24CXX 25CXX 93CXX | HCS200 HCS300 HCS301 |
|---|-----------|----------|----------|-----------|----------|-----------|----------|-----------|----------|-------------------|-------------------------|----------------------------|
| Emulator Products | | | | | | | | | | | | |
| PICMASTER® / PICMASTER-CE In-Circuit Emulator | ✓ | ✓ | ✓ | ✓ | ✓ | ✓ | ✓ | ✓ | ✓ | Available 3097 | | |
| ICEPIC Low-Cost In-Circuit Emulator | ✓ | | ✓ | ✓ | ✓ | ✓ | ✓ | | | | | |
| Software Tools | | | | | | | | | | | | |
| MPLAB™ Integrated Development Environment | ✓ | ✓ | ✓ | ✓ | ✓ | ✓ | ✓ | ✓ | ✓ | ✓ | | |
| MPLAB™ C Compiler | ✓ | ✓ | ✓ | ✓ | ✓ | ✓ | ✓ | ✓ | ✓ | ✓ | | |
| fuzzyTECH®-MP Explorer/Edition Fuzzy Logic Dev. Tool | ✓ | ✓ | ✓ | ✓ | ✓ | ✓ | ✓ | ✓ | ✓ | | | |
| MP-DriveWay™ Applications Code Generator | | | ✓ | ✓ | ✓ | ✓ | ✓ | | ✓ | | | |
| Total Endurance™ Software Model | | | | | | | | | | | ✓ | |
| Programmers | | | | | | | | | | | | |
| PICSTART® Lite Ultra Low-Cost Dev. Kit | | | ✓ | | ✓ | ✓ | ✓ | | | | | |
| PICSTART® Plus Low-Cost Universal Dev. Kit | ✓ | ✓ | ✓ | ✓ | ✓ | ✓ | ✓ | ✓ | ✓ | ✓ | ✓ | ✓ |
| PRO MATE® II Universal Programmer | ✓ | ✓ | ✓ | ✓ | ✓ | ✓ | ✓ | | ✓ | ✓ | ✓ | ✓ |
| KEELOQ® Programmer | | | | | | | | | | | | |
| SEEVAL® Designers Kit | | | | | | | | | | | ✓ | |
| Demo Boards | | | | | | | | | | | | |
| PICDEM-1 | | | ✓ | ✓ | | | ✓ | | ✓ | | | |
| PICDEM-2 | | | | | ✓ | | | | | | | |
| PICDEM-3 | | | | | | | | ✓ | | | | |
| KEELOQ® Evaluation Kit | | | | | | | | | | | | ✓ |

10.0 ELECTRICAL SPECIFICATIONS

Absolute Maximum Ratings †

| | |
|---|--------------------|
| Ambient Temperature under bias | -40° to +125°C |
| Storage Temperature | -65° to +150°C |
| Voltage on any pin with respect to VSS (except VDD and $\overline{\text{MCLR}}$) | -0.6V to VDD +0.6V |
| Voltage on VDD with respect to VSS | 0 to +7.5V |
| Voltage on $\overline{\text{MCLR}}$ with respect to VSS (Note 2) | 0 to +14V |
| Total power Dissipation (Note 1) | 1.0W |
| Maximum Current out of VSS pin | 300 mA |
| Maximum Current into VDD pin | 250 mA |
| Input Clamp Current, I _{IK} (V _I < 0 or V _I > V _{DD}) | ±20 mA |
| Output Clamp Current, I _{OK} (V _O < 0 or V _O > V _{DD}) | ±20 mA |
| Maximum Output Current sunk by any I/O pin | 25 mA |
| Maximum Output Current sourced by any I/O pin | 25 mA |
| Maximum Current sunk by PORTA and PORTB | 200 mA |
| Maximum Current sourced by PORTA and PORTB | 200 mA |

Note 1: Power dissipation is calculated as follows: $P_{DIS} = V_{DD} \times \{I_{DD} - \sum I_{OH}\} + \sum \{(V_{DD} - V_{OH}) \times I_{OH}\} + \sum (V_{OL} \times I_{OL})$

† **NOTICE:** Stresses above those listed under "Absolute Maximum Ratings" may cause permanent damage to the device. This is a stress rating only and functional operation of the device at those or any other conditions above those indicated in the operation listings of this specification is not implied. Exposure to maximum rating conditions for extended periods may affect device reliability.

PIC16C55X(A)

TABLE 10-1: CROSS REFERENCE OF DEVICE SPECS FOR OSCILLATOR CONFIGURATIONS AND FREQUENCIES OF OPERATION (COMMERCIAL DEVICES)

| OSC | PIC16C55X-04 | PIC16C55XA-04 | PIC16C55X-20 | PIC16C55XA-20 | PIC16LC55X-04 | PIC16C55X JW Devices | PIC16C55XA JW Devices |
|-----|--|--|--|--|--|--|--|
| RC | VDD: 3.0V to 5.5V IDD: 3.3 mA max. @5.5V IPD: 20 μ A max. @4.0V Freq: 4.0 MHz max. | VDD: 3.0V to 5.5V IDD: 3.3 mA max. @5.5V IPD: 20 μ A max. @4.0V Freq: 4.0 MHz max. | VDD: 4.5V to 5.5V IDD: 1.8 mA typ. @5.5V IPD: 1.0 μ A typ. @4.5V Freq: 4.0 MHz max. | VDD: 4.5V to 5.5V IDD: 1.8 mA typ. @5.5V IPD: 1.0 μ A typ. @4.5V Freq: 4.0 MHz max. | VDD: 2.5V to 5.5V IDD: 1.4 mA typ. @3.0V IPD: 0.7 μ A typ. @3.0V Freq: 4.0 MHz max. | VDD: 3.0V to 5.5V IDD: 3.3 mA max. @5.5V IPD: 20 μ A max. @4.0V Freq: 4.0 MHz max. | VDD: 3.0V to 5.5V IDD: 3.3 mA max. @5.5V IPD: 20 μ A max. @4.0V Freq: 4.0 MHz max. |
| XT | VDD: 3.0V to 5.5V IDD: 3.3 mA max. @5.5V IPD: 20 μ A max. @4.0V Freq: 4.0 MHz max. | VDD: 3.0V to 5.5V IDD: 3.3 mA max. @5.5V IPD: 20 μ A max. @4.0V Freq: 4.0 MHz max. | VDD: 4.5V to 5.5V IDD: 1.8 mA typ. @5.5V IPD: 1.0 μ A typ. @4.5V Freq: 4.0 MHz max. | VDD: 4.5V to 5.5V IDD: 1.8 mA typ. @5.5V IPD: 1.0 μ A typ. @4.5V Freq: 4.0 MHz max. | VDD: 2.5V to 5.5V IDD: 1.4 mA typ. @3.0V IPD: 0.7 μ A typ. @3.0V Freq: 4.0 MHz max. | VDD: 3.0V to 5.5V IDD: 3.3 mA max. @5.5V IPD: 20 μ A max. @4.0V Freq: 4.0 MHz max. | VDD: 3.0V to 5.5V IDD: 3.3 mA max. @5.5V IPD: 20 μ A max. @4.0V Freq: 4.0 MHz max. |
| HS | VDD: 4.5V to 5.5V IDD: 9.0 mA typ. @5.5V IPD: 1.0 μ A typ. @4.0V Freq: 4.0 MHz max. | VDD: 4.5V to 5.5V IDD: 9.0 mA typ. @5.5V IPD: 1.0 μ A typ. @4.0V Freq: 4.0 MHz max. | VDD: 4.5V to 5.5V IDD: 20 mA max. @5.5V IPD: 1.0 μ A typ. @4.5V Freq: 20 MHz max. | VDD: 4.5V to 5.5V IDD: 20 mA max. @5.5V IPD: 1.0 μ A typ. @4.5V Freq: 20 MHz max. | Do not use in HS mode | VDD: 4.5V to 5.5V IDD: 20 mA max. @5.5V IPD: 1.0 μ A typ. @4.5V Freq: 20 MHz max. | VDD: 4.5V to 5.5V IDD: 20 mA max. @5.5V IPD: 1.0 μ A typ. @4.5V Freq: 20 MHz max. |
| LP | VDD: 3.0V to 5.5V IDD: 35 μ A typ. @32 kHz, 3.0V IPD: 1.0 μ A typ. @4.0V Freq: 200 kHz max. | VDD: 3.0V to 5.5V IDD: 35 μ A typ. @32 kHz, 3.0V IPD: 1.0 μ A typ. @4.0V Freq: 200 kHz max. | Do not use in LP mode | Do not use in LP mode | VDD: 2.5V to 5.5V IDD: 32 μ A max. @32 kHz, 3.0V IPD: 9.0 μ A max. @3.0V Freq: 200 kHz max. | VDD: 2.5V to 5.5V IDD: 32 μ A max. @32 kHz, 3.0V IPD: 9.0 μ A max. @3.0V Freq: 200 kHz max. | VDD: 3.0V to 5.5V IDD: 32 μ A max. @32 kHz, 3.0V IPD: 9.0 μ A max. @3.0V Freq: 200 kHz max. |

The shaded sections indicate oscillator selections which are tested for functionality, but not for MIN/MAX specifications. It is recommended that the user select the device type that guarantees the specifications required.

10.1 DC CHARACTERISTICS: PIC16C55X(A)-04 (Commercial, Industrial, Extended) PIC16C55X(A)-20 (Commercial, Industrial, Extended)

| Standard Operating Conditions (unless otherwise stated) | | | | | | | |
|---|----------------------|--|------------|------------------|-----------------|--------------------------------|--|
| Operating temperature $-40^{\circ}\text{C} \leq T_A \leq +85^{\circ}\text{C}$ for industrial and $0^{\circ}\text{C} \leq T_A \leq +70^{\circ}\text{C}$ for commercial and $-40^{\circ}\text{C} \leq T_A \leq +125^{\circ}\text{C}$ for extended | | | | | | | |
| Param No. | Sym | Characteristic | Min | Typ† | Max | Units | Conditions |
| D001 D001A | VDD | Supply Voltage | 3.0 4.5 | - - | 5.5 5.5 | V V | XT, RC and LP osc configuration HS osc configuration |
| D002 | VDR | RAM Data Retention Voltage (Note 1) | - | 1.5* | - | V | Device in SLEEP mode |
| D003 | VPOR | VDD start voltage to ensure Power-on Reset | - | VSS | - | V | See section on power-on reset for details |
| D004 | SVDD | VDD rise rate to ensure Power-on Reset | 0.05* | - | - | V/ms | See section on power-on reset for details |
| D010 D010A D013 | IDD | Supply Current (Note 2) | - | 1.8 35 9.0 | 3.3 70 20 | mA μA mA | XT and RC osc configuration FOSC = 4 MHz, VDD = 5.5V, WDT disabled (Note 4) LP osc configuration, PIC16C55X-04 only FOSC = 32 kHz, VDD = 4.0V, WDT disabled HS osc configuration FOSC = 20 MHz, VDD = 5.5V, WDT disabled |
| | $\Delta\text{IWD T}$ | WDT Current (Note 5) | - | 6.0 | 20 25 | μA μA | VDD = 4.0V (+85°C to +125°C) |
| D020 | IPD | Power Down Current (Note 3) | - | 1.0 | 2.5 15 | μA μA | VDD=4.0V, WDT disabled (+85°C to +125°C) |
| | $\Delta\text{IWD T}$ | WDT Current (Note 5) | - | 6.0 | 20 | μA | VDD=4.0V (+85°C to +125°C) |

* These parameters are characterized but not tested.

† Data in "Typ" column is at 5.0V, 25°C, unless otherwise stated. These parameters are for design guidance only and are not tested.

Note 1: This is the limit to which VDD can be lowered in SLEEP mode without losing RAM data.

2: The supply current is mainly a function of the operating voltage and frequency. Other factors such as I/O pin loading and switching rate, oscillator type, internal code execution pattern, and temperature also have an impact on the current consumption.

The test conditions for all IDD measurements in active operation mode are:

OSC1 = external square wave, from rail to rail; all I/O pins configured as input, pulled to VDD,
MCLR = VDD; WDT enabled/disabled as specified.

3: The power down current in SLEEP mode does not depend on the oscillator type. Power down current is measured with the part in SLEEP mode, with all I/O pins configured as input and tied to VDD or VSS.

4: For RC osc configuration, current through Rext is not included. The current through the resistor can be estimated by the formula $I_r = V_{DD}/2R_{ext}$ (mA) with Rext in k Ω .

5: The Δ current is the additional current consumed when this peripheral is enabled. This current should be added to the base IDD or IPD measurement.

PIC16C55X(A)

10.2 DC CHARACTERISTICS: PIC16LC55X-04 (Commercial, Industrial, Extended)

| Standard Operating Conditions (unless otherwise stated) | | | | | | | |
|---|---------------------|--|------------|------|------------|---------------|--|
| Operating temperature $-40^{\circ}\text{C} \leq \text{TA} \leq +85^{\circ}\text{C}$ for industrial and $0^{\circ}\text{C} \leq \text{TA} \leq +70^{\circ}\text{C}$ for commercial and $-40^{\circ}\text{C} \leq \text{TA} \leq +125^{\circ}\text{C}$ for extended | | | | | | | |
| Param No. | Sym | Characteristic | Min | Typ† | Max | Units | Conditions |
| D001 | VDD | Supply Voltage | 3.0 2.5 | - | 5.5 5.5 | V | XT and RC osc configuration LP osc configuration |
| D002 | VDR | RAM Data Retention Voltage (Note 1) | - | 1.5* | - | V | Device in SLEEP mode |
| D003 | VPOR | VDD start voltage to ensure Power-on Reset | - | VSS | - | V | See section on Power-on Reset for details |
| D004 | SVDD | VDD rise rate to ensure Power-on Reset | 0.05* | - | - | V/ms | See section on Power-on Reset for details |
| D010 | IDD | Supply Current (Note 2) | - | 1.4 | 2.5 | mA | XT and RC osc configuration FOSC = 2.0 MHz, VDD = 3.0V, WDT disabled (Note 4) |
| D010A | | | - | 26 | 53 | μA | LP osc configuration FOSC = 32 kHz, VDD = 3.0V, WDT disabled |
| | ΔIWDT | WDT Current (Note 5) | - | 6.0 | 15 | μA | VDD = 3.0V |
| D020 | IPD | Power Down Current (Note 3) | - | 0.7 | 2 | μA | VDD=3.0V, WDT disabled |
| | ΔIWDT | WDT Current (Note 5) | - | 6.0 | 15 | μA | VDD=3.0V |

* These parameters are characterized but not tested.

† Data in "Typ" column is at 5.0V, 25°C, unless otherwise stated. These parameters are for design guidance only and are not tested.

Note 1: This is the limit to which VDD can be lowered in SLEEP mode without losing RAM data.

2: The supply current is mainly a function of the operating voltage and frequency. Other factors such as I/O pin loading and switching rate, oscillator type, internal code execution pattern, and temperature also have an impact on the current consumption.

The test conditions for all IDD measurements in active operation mode are:

OSC1=external square wave, from rail to rail; all I/O pins configured as input, pulled to VDD,

MCLR = VDD; WDT enabled/disabled as specified.

3: The power down current in SLEEP mode does not depend on the oscillator type. Power down current is measured with the part in SLEEP mode, with all I/O pins configured as input and tied to VDD or VSS.

4: For RC osc configuration, current through Rext is not included. The current through the resistor can be estimated by the formula $I_r = V_{DD}/2R_{ext}$ (mA) with Rext in k Ω .

5: The Δ current is the additional current consumed when this peripheral is enabled. This current should be added to the base IDD or IPD measurement.

10.3 DC CHARACTERISTICS: PIC16C55X(A) (Commercial, Industrial, Extended) PIC16LC55X (Commercial, Industrial, Extended)

| Standard Operating Conditions (unless otherwise stated) | | | | | | | |
|---|----------|--|----------------------|--------|-----------------------------------|---------------|---|
| Operating temperature $-40^{\circ}\text{C} \leq \text{TA} \leq +85^{\circ}\text{C}$ for industrial and $0^{\circ}\text{C} \leq \text{TA} \leq +70^{\circ}\text{C}$ for commercial and $-40^{\circ}\text{C} \leq \text{TA} \leq +125^{\circ}\text{C}$ for automotive | | | | | | | |
| Operating voltage V_{DD} range as described in DC spec Table 10-1 | | | | | | | |
| Param. No. | Sym | Characteristic | Min | Typ† | Max | Unit | Conditions |
| D030 | V_{IL} | Input Low Voltage I/O ports with TTL buffer | V_{SS} | - | 0.8V 0.15 V_{DD} | V | $V_{DD} = 4.5\text{V to } 5.5\text{V}$ otherwise |
| D031 | | with Schmitt Trigger input | V_{SS} | - | 0.2 V_{DD} | V | Note1 |
| D032 | | $\overline{\text{MCLR}}$, RA4/T0CKI, OSC1 (in RC mode) | V_{SS} | - | 0.2 V_{DD} | V | |
| D033 | | OSC1 (in XT* and HS) OSC1 (in LP*) | V_{SS} V_{SS} | - - | 0.3 V_{DD} 0.6 V_{DD} -1.0 | V V | |
| D040 | V_{IH} | Input High Voltage I/O ports with TTL buffer | 2.0V | - | V_{DD} | V | Note1 |
| D041 | | with Schmitt Trigger input | 0.8 V_{DD} | - | V_{DD} | V | |
| D042 | | $\overline{\text{MCLR}}$ RA4/T0CKI | 0.8 V_{DD} | - | V_{DD} | V | |
| D043 | | OSC1 (XT*, HS and LP*) | 0.7 V_{DD} | - | V_{DD} | V | |
| D043A | | OSC1 (in RC mode) | 0.9 V_{DD} | - | V_{DD} | V | |
| D070 | IPURB | PORTB weak pull-up current | 50 | 200 | 400 | μA | $V_{DD} = 5.0\text{V}$, $V_{PIN} = V_{SS}$ |
| D060 | I_{IL} | Input Leakage Current (Notes 2, 3) I/O ports (Except PORTA) | - | - | ± 1.0 | μA | $V_{SS} \leq V_{PIN} \leq V_{DD}$, pin at hi-impedance |
| D061 | | PORTA | - | - | ± 0.5 | μA | $V_{SS} \leq V_{PIN} \leq V_{DD}$, pin at hi-impedance |
| D063 | | RA4/T0CKI | - | - | ± 1.0 | μA | $V_{SS} \leq V_{PIN} \leq V_{DD}$ |
| D063 | | OSC1, $\overline{\text{MCLR}}$ | - | - | ± 5.0 | μA | $V_{SS} \leq V_{PIN} \leq V_{DD}$, XT, HS and LP osc configuration |
| D080 | V_{OL} | Output Low Voltage I/O ports | - | - | 0.6 | V | $I_{OL}=8.5\text{ mA}$, $V_{DD}=4.5\text{V}$, -40° to $+85^{\circ}\text{C}$ |
| D083 | | OSC2/CLKOUT (RC only) | - | - | 0.6 | V | $I_{OL}=7.0\text{ mA}$, $V_{DD}=4.5\text{V}$, $+125^{\circ}\text{C}$ |
| D083 | | | - | - | 0.6 | V | $I_{OL}=1.6\text{ mA}$, $V_{DD}=4.5\text{V}$, -40° to $+85^{\circ}\text{C}$ |
| D083 | | | - | - | 0.6 | V | $I_{OL}=1.2\text{ mA}$, $V_{DD}=4.5\text{V}$, $+125^{\circ}\text{C}$ |
| D090 | V_{OH} | Output High Voltage (Note 3) I/O ports (Except RA4) | $V_{DD}-0.7$ | - | - | V | $I_{OH}=-3.0\text{ mA}$, $V_{DD}=4.5\text{V}$, -40° to $+85^{\circ}\text{C}$ |
| D092 | | | $V_{DD}-0.7$ | - | - | V | $I_{OH}=-2.5\text{ mA}$, $V_{DD}=4.5\text{V}$, $+125^{\circ}\text{C}$ |
| D092 | | OSC2/CLKOUT | $V_{DD}-0.7$ | - | - | V | $I_{OH}=-1.3\text{ mA}$, $V_{DD}=4.5\text{V}$, -40° to $+85^{\circ}\text{C}$ |
| D092 | | (RC only) | $V_{DD}-0.7$ | - | - | V | $I_{OH}=-1.0\text{ mA}$, $V_{DD}=4.5\text{V}$, $+125^{\circ}\text{C}$ |
| * | V_{OD} | Open-Drain High Voltage | | | 14* | V | RA4 pin |

* These parameters are characterized but not tested.

† Data in "Typ" column is at 5.0V, 25°C unless otherwise stated. These parameters are for design guidance only and are not tested.

- Note 1: In RC oscillator configuration, the OSC1 pin is a Schmitt Trigger input. It is not recommended that the PIC16C55X(A) be driven with external clock in RC mode.
- 2: The leakage current on the $\overline{\text{MCLR}}$ pin is strongly dependent on applied voltage level. The specified levels represent normal operating conditions. Higher leakage current may be measured at different input voltages.
- 3: Negative current is defined as coming out of the pin.

PIC16C55X(A)

10.3 DC CHARACTERISTICS: PIC16C55X(A) (Commercial, Industrial, Extended) PIC16LC55X (Commercial, Industrial, Extended) (Cont.)

| Standard Operating Conditions (unless otherwise stated) | | | | | | | |
|---|-------|--------------------------------|-----|------|-----|------|--|
| Operating temperature $-40^{\circ}\text{C} \leq \text{TA} \leq +85^{\circ}\text{C}$ for industrial and $0^{\circ}\text{C} \leq \text{TA} \leq +70^{\circ}\text{C}$ for commercial and $-40^{\circ}\text{C} \leq \text{TA} \leq +125^{\circ}\text{C}$ for automotive | | | | | | | |
| Operating voltage V_{DD} range as described in DC spec Table 10-1 | | | | | | | |
| Param. No. | Sym | Characteristic | Min | Typ† | Max | Unit | Conditions |
| Capacitive Loading Specs on Output Pins | | | | | | | |
| D100 | Cosc2 | OSC2 pin | | | 15 | pF | In XT, HS and LP modes when external clock used to drive OSC1. |
| D101 | Cio | All I/O pins/OSC2 (in RC mode) | | | 50 | pF | |

* These parameters are characterized but not tested.

† Data in "Typ" column is at 5.0V, 25°C unless otherwise stated. These parameters are for design guidance only and are not tested.

- Note 1: In RC oscillator configuration, the OSC1 pin is a Schmitt Trigger input. It is not recommended that the PIC16C55X(A) be driven with external clock in RC mode.
- 2: The leakage current on the $\overline{\text{MCLR}}$ pin is strongly dependent on applied voltage level. The specified levels represent normal operating conditions. Higher leakage current may be measured at different input voltages.
- 3: Negative current is defined as coming out of the pin.

10.4 Timing Parameter Symbology

The timing parameter symbols have been created with one of the following formats:

1. TppS2ppS
2. TppS

| | | | |
|----------|-----------|---|------|
| T | | | |
| F | Frequency | T | Time |

Lowercase subscripts (pp) and their meanings:

| | | | |
|-----------|----------|----|-------|
| pp | | | |
| ck | CLKOUT | os | OSC1 |
| io | I/O port | t0 | T0CKI |
| mc | MCLR | | |

Uppercase letters and their meanings:

| | | | |
|----------|------------------------|---|--------------|
| S | | | |
| F | Fall | P | Period |
| H | High | R | Rise |
| I | Invalid (Hi-impedance) | V | Valid |
| L | Low | Z | Hi-Impedance |

FIGURE 10-1: LOAD CONDITIONS

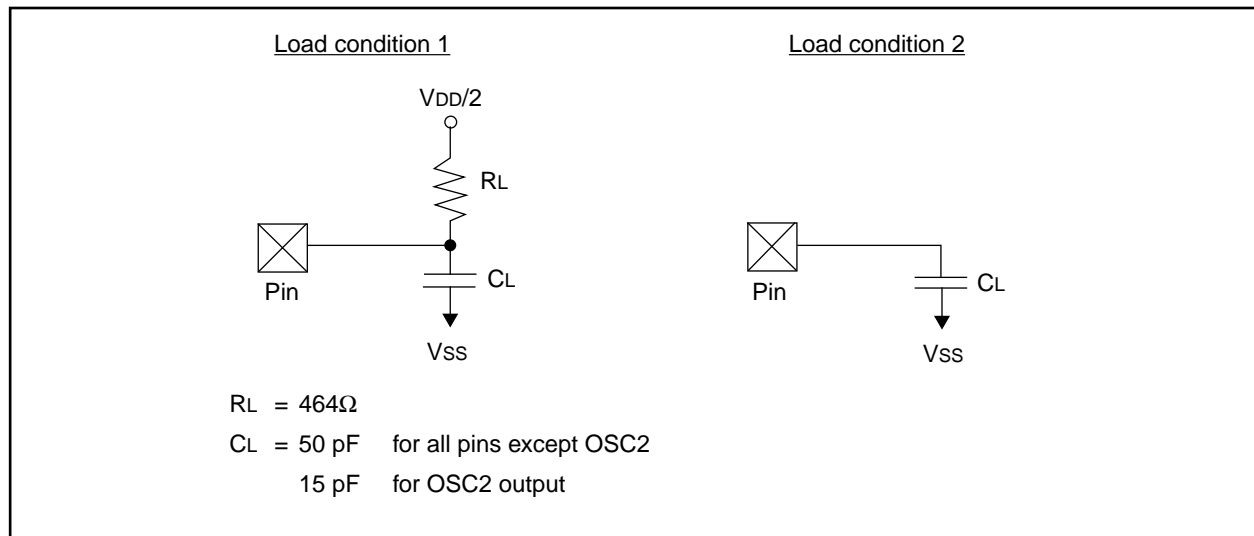

PIC16C55X(A)

10.5 Timing Diagrams and Specifications

FIGURE 10-2: EXTERNAL CLOCK TIMING

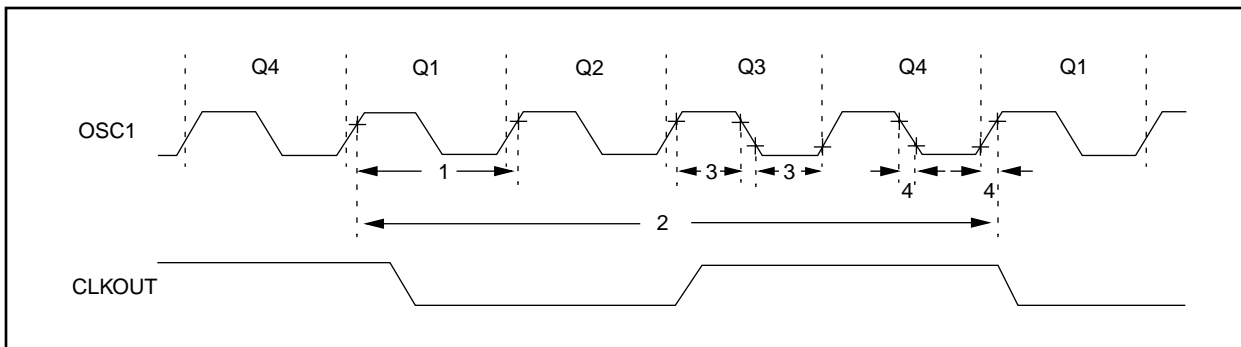

TABLE 10-2: EXTERNAL CLOCK TIMING REQUIREMENTS

| Parameter No. | Sym | Characteristic | Min | Typ† | Max | Units | Conditions |
|---------------|------------|--|------|-------|--------|-------------|------------------------------|
| | Fos | External CLKIN Frequency (Note 1) | DC | — | 4 | MHz | XT and RC osc mode, VDD=5.0V |
| | | | DC | — | 20 | MHz | HS osc mode |
| | | | DC | — | 200 | kHz | LP osc mode |
| | | Oscillator Frequency (Note 1) | DC | — | 4 | MHz | RC osc mode, VDD=5.0V |
| | | | 0.1 | — | 4 | MHz | XT osc mode |
| | | | 1 | — | 20 | MHz | HS osc mode |
| DC | | | — | 200 | kHz | LP osc mode | |
| 1 | Tosc | External CLKIN Period (Note 1) | 250 | — | — | ns | XT and RC osc mode |
| | | | 50 | — | — | ns | HS osc mode |
| | | | 5 | — | — | µs | LP osc mode |
| | | Oscillator Period (Note 1) | 250 | — | — | ns | RC osc mode |
| | | | 250 | — | 10,000 | ns | XT osc mode |
| | | | 50 | — | 1,000 | ns | HS osc mode |
| 5 | | | — | — | µs | LP osc mode | |
| 2 | Tcy | Instruction Cycle Time (Note 1) | 1.0 | Fos/4 | DC | µs | Tcy=FOS/4 |
| 3* | TosL, TosH | External Clock in (OSC1) High or Low Time | 100* | — | — | ns | XT osc mode |
| | | | 2* | — | — | µs | LP osc mode |
| | | | 20* | — | — | ns | HS osc mode |
| 4* | TosR, TosF | External Clock in (OSC1) Rise or Fall Time | 25* | — | — | ns | XT osc mode |
| | | | 50* | — | — | ns | LP osc mode |
| | | | 15* | — | — | ns | HS osc mode |

* These parameters are characterized but not tested.

† Data in "Typ" column is at 5.0V, 25°C unless otherwise stated. These parameters are for design guidance only and are not tested.

Note 1: Instruction cycle period (Tcy) equals four times the input oscillator time-base period. All specified values are based on characterization data for that particular oscillator type under standard operating conditions with the device executing code. Exceeding these specified limits may result in an unstable oscillator operation and/or higher than expected current consumption. All devices are tested to operate at "min." values with an external clock applied to the OSC1 pin.

When an external clock input is used, the "Max." cycle time limit is "DC" (no clock) for all devices.

FIGURE 10-3: CLKOUT AND I/O TIMING

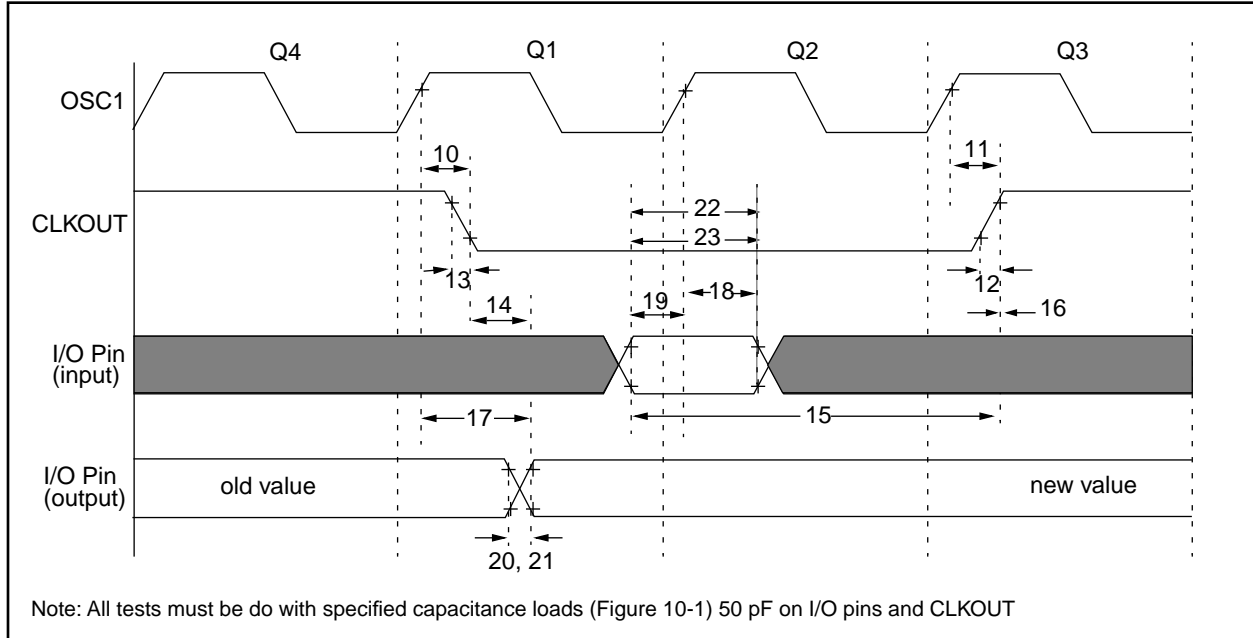

TABLE 10-3: CLKOUT AND I/O TIMING REQUIREMENTS

| Parameter # | Sym | Characteristic | Min | Typ† | Max | Units |
|-------------|----------|---|--------------|------|-----|-------|
| 10* | TosH2ckL | OSC1↑ to CLKOUT↓ (Note1) | — | 75 | 200 | ns |
| | | | — | — | 400 | ns |
| 11* | TosH2ckH | OSC1↑ to CLKOUT↑ (Note1) | — | 75 | 200 | ns |
| | | | — | — | 400 | ns |
| 12* | TckR | CLKOUT rise time (Note1) | — | 35 | 100 | ns |
| | | | — | — | 200 | ns |
| 13* | TckF | CLKOUT fall time (Note1) | — | 35 | 100 | ns |
| | | | — | — | 200 | ns |
| 14* | TckL2ioV | CLKOUT ↓ to Port out valid (Note1) | — | — | 20 | ns |
| 15* | TioV2ckH | Port in valid before CLKOUT ↑ (Note1) | Tosc +200 ns | — | — | ns |
| | | | Tosc +400 ns | — | — | ns |
| 16* | TckH2ioI | Port in hold after CLKOUT ↑ (Note1) | 0 | — | — | ns |
| 17* | TosH2ioV | OSC1↑ (Q1 cycle) to Port out valid | — | 50 | 150 | ns |
| | | | — | — | 300 | ns |
| 18* | TosH2ioI | OSC1↑ (Q2 cycle) to Port input invalid (I/O in hold time) | 100 | — | — | ns |
| | | | 200 | — | — | ns |
| 19* | TioV2osH | Port input valid to OSC1↑ (I/O in setup time) | 0 | — | — | ns |
| 20* | TioR | Port output rise time | — | 10 | 40 | ns |
| | | | — | — | 80 | ns |
| 21* | TioF | Port output fall time | — | 10 | 40 | ns |
| | | | — | — | 80 | ns |
| 22* | Tinp | RB0/INT pin high or low time | 25 | — | — | ns |
| | | | 40 | — | — | ns |
| 23 | Trbp | RB<7:4> change interrupt high or low time | Tcy | — | — | ns |

* These parameters are characterized but not tested

† Data in "Typ" column is at 5.0V, 25°C unless otherwise stated. These parameters are for design guidance only and are not tested.

Note 1: Measurements are taken in RC Mode where CLKOUT output is 4 x TOSC

PIC16C55X(A)

FIGURE 10-4: RESET, WATCHDOG TIMER, OSCILLATOR START-UP TIMER AND POWER-UP TIMER TIMING

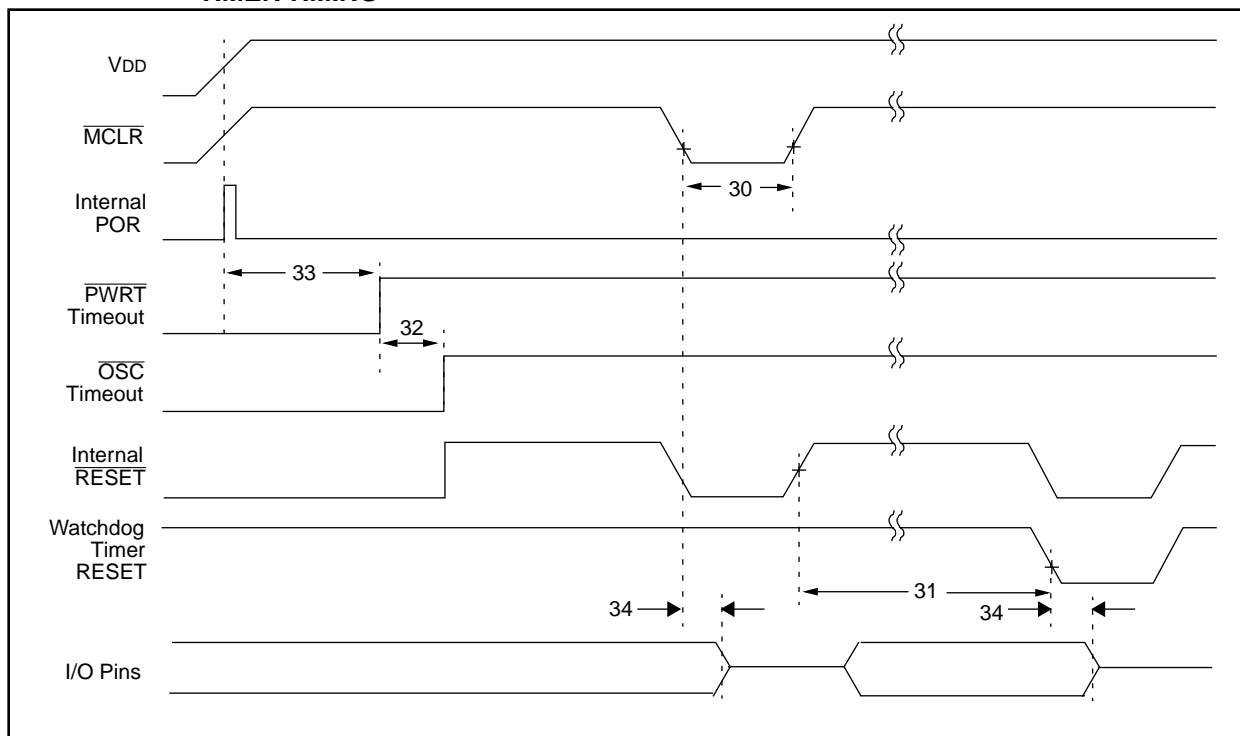

TABLE 10-4: RESET, WATCHDOG TIMER, OSCILLATOR START-UP TIMER AND POWER-UP TIMER REQUIREMENTS

| Parameter No. | Sym | Characteristic | Min | Typ† | Max | Units | Conditions |
|---------------|-------|---|------|-----------------------|------|-------|--------------------------------|
| 30 | Tmcl | MCLR Pulse Width (low) | 2000 | — | — | ns | -40° to +85°C |
| 31 | Twdt | Watchdog Timer Time-out Period (No Prescaler) | 7* | 18 | 33* | ms | VDD = 5.0V, -40° to +85°C |
| 32 | Tost | Oscillation Start-up Timer Period | — | 1024 T _{osc} | — | — | T _{osc} = OSC1 period |
| 33 | Tpwrt | Power-up Timer Period | 28* | 72 | 132* | ms | VDD = 5.0V, -40° to +85°C |
| 34 | Tioz | I/O hi-impedance from MCLR low | — | — | 2.0 | μs | |

* These parameters are characterized but not tested.

† Data in "Typ" column is at 5.0V, 25°C unless otherwise stated. These parameters are for design guidance only and are not tested.

FIGURE 10-5: TIMER0 CLOCK TIMING

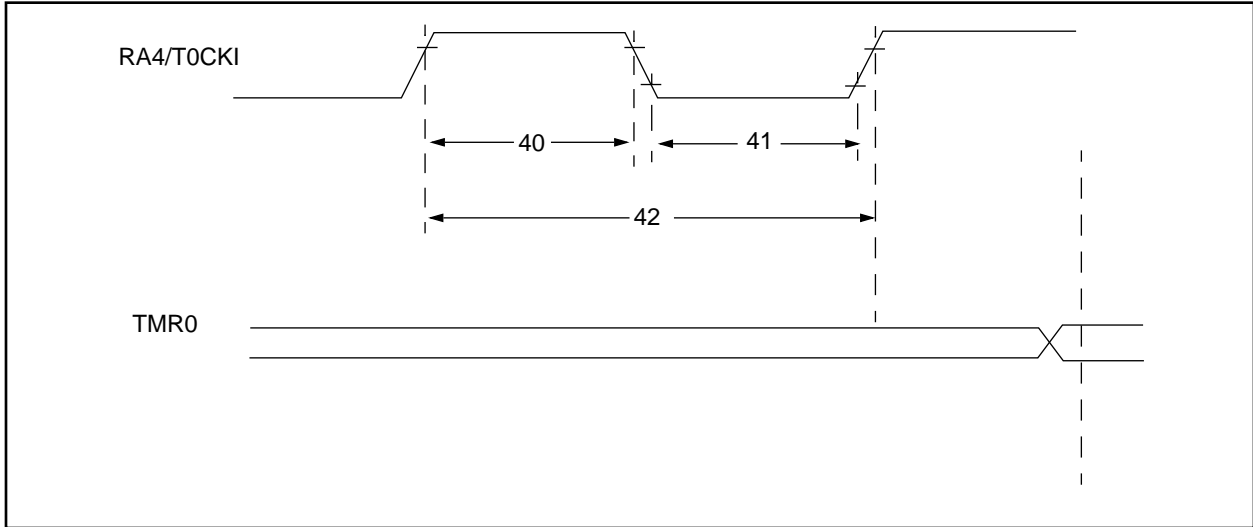

TABLE 10-5: TIMER0 CLOCK REQUIREMENTS

| Parameter No. | Sym | Characteristic | Min | Typ† | Max | Units | Conditions |
|---------------|------|------------------------|---------------------------|---------------------|-----|-------|--|
| 40 | Tt0H | T0CKI High Pulse Width | No Prescaler | $0.5 T_{CY} + 20^*$ | — | — | ns |
| | | | With Prescaler | 10* | — | — | ns |
| 41 | Tt0L | T0CKI Low Pulse Width | No Prescaler | $0.5 T_{CY} + 20^*$ | — | — | ns |
| | | | With Prescaler | 10* | — | — | ns |
| 42 | Tt0P | T0CKI Period | $\frac{T_{CY} + 40^*}{N}$ | — | — | ns | N = prescale value (1, 2, 4, ..., 256) |

* These parameters are characterized but not tested.

† Data in "Typ" column is at 5.0V, 25°C unless otherwise stated. These parameters are for design guidance only and are not tested.

FIGURE 10-6: LOAD CONDITIONS

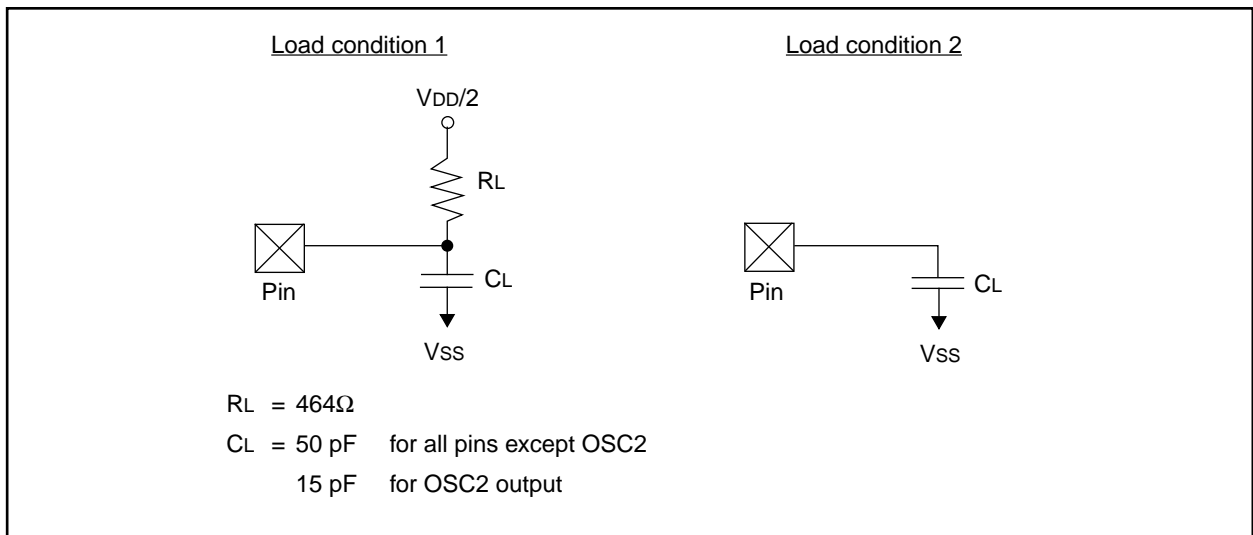

PIC16C55X(A)

NOTES:

11.0 PACKAGING INFORMATION

Ceramic CERDIP Dual In-Line Family

| Symbol List for Ceramic CERDIP Dual In-Line Package Parameters | |
|--|---|
| Symbol | Description of Parameters |
| α | Angular spacing between min. and max. lead positions measured at the gauge plane |
| A | Distance between seating plane to highest point of body (lid) |
| A1 | Distance between seating plane and base plane |
| A2 | Distance from base plane to highest point of body (lid) |
| A3 | Base body thickness |
| B | Width of terminal leads |
| B1 | Width of terminal lead shoulder which locate seating plane (standoff geometry optional) |
| C | Thickness of terminal leads |
| D | Largest overall package parameter of length |
| D1 | Body width parameters not including leads |
| E | Largest overall package width parameter outside of lead |
| E1 | Body width parameter - end lead center to end lead center |
| eA | Linear spacing of true minimum lead position center line to center line |
| eB | Linear spacing between true lead position outside of lead to outside of lead |
| e1 | Linear spacing between center lines of body standoffs (terminal leads) |
| L | Distance from seating plane to end of lead |
| N | Total number of potentially usable lead positions |
| S | Distance from true position center line of Number 1 lead to the extremity of the body |
| S1 | Distance from other end lead edge positions to the extremity of the body |

Notes:

1. Controlling parameter: inches.
2. Parameter "e1" ("e") is non-cumulative.
3. Seating plane (standoff) is defined by board hole size.
4. Parameter "B1" is nominal.

PIC16C55X(A)

11.1 18-Lead Ceramic CERDIP Dual In-line with Window (300 mil)

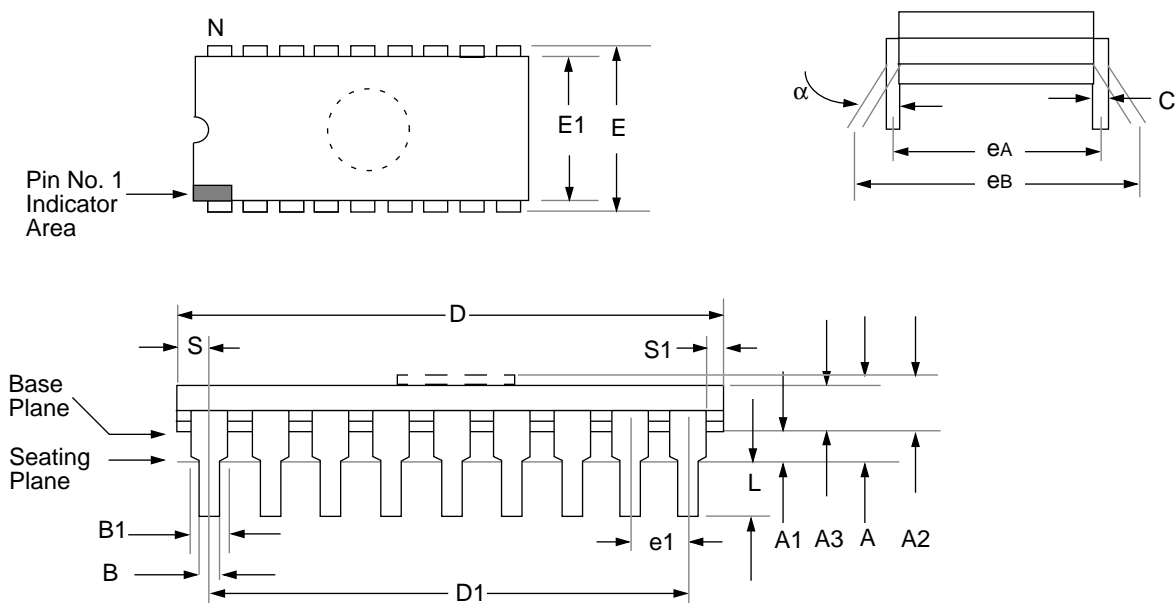

Package Group: Ceramic CERDIP Dual In-Line (CDP)

| Symbol | Millimeters | | | Inches | | |
|----------|-------------|--------|-----------|--------|-------|-----------|
| | Min | Max | Notes | Min | Max | Notes |
| α | 0° | 10° | | 0° | 10° | |
| A | — | 5.080 | | — | 0.200 | |
| A1 | 0.381 | 1.7780 | | 0.015 | 0.070 | |
| A2 | 3.810 | 4.699 | | 0.150 | 0.185 | |
| A3 | 3.810 | 4.445 | | 0.150 | 0.175 | |
| B | 0.355 | 0.585 | | 0.014 | 0.023 | |
| B1 | 1.270 | 1.651 | Typical | 0.050 | 0.065 | Typical |
| C | 0.203 | 0.381 | Typical | 0.008 | 0.015 | Typical |
| D | 22.352 | 23.622 | | 0.880 | 0.930 | |
| D1 | 20.320 | 20.320 | Reference | 0.800 | 0.800 | Reference |
| E | 7.620 | 8.382 | | 0.300 | 0.330 | |
| E1 | 5.588 | 7.874 | | 0.220 | 0.310 | |
| e1 | 2.540 | 2.540 | Reference | 0.100 | 0.100 | Reference |
| eA | 7.366 | 8.128 | Typical | 0.290 | 0.320 | Typical |
| eB | 7.620 | 10.160 | | 0.300 | 0.400 | |
| L | 3.175 | 3.810 | | 0.125 | 0.150 | |
| N | 18 | 18 | | 18 | 18 | |
| S | 0.508 | 1.397 | | 0.020 | 0.055 | |
| S1 | 0.381 | 1.270 | | 0.015 | 0.050 | |

Plastic Dual In-Line Family

| Symbol List for Plastic In-Line Package Parameters | |
|--|---|
| Symbol | Description of Parameters |
| α | Angular spacing between min. and max. lead positions measured at the gauge plane |
| A | Distance between seating plane to highest point of body |
| A1 | Distance between seating plane and base plane |
| A2 | Base body thickness |
| B | Width of terminal leads |
| B1 | Width of terminal lead shoulder which locate seating plane (standoff geometry optional) |
| C | Thickness of terminal leads |
| D | Largest overall package parameter of length |
| D1 | Body length parameter - end lead center to end lead center |
| E | Largest overall package width parameter outside of lead |
| E1 | Body width parameters not including leads |
| eA | Linear spacing of true minimum lead position center line to center line |
| eB | Linear spacing between true lead position outside of lead to outside of lead |
| e1 | Linear spacing between center lines of body standoffs (terminal leads) |
| L | Distance from seating plane to end of lead |
| N | Total number of potentially usable lead positions |
| S | Distance from true position center line of Number 1 lead to the extremity of the body |
| S1 | Distance from other end lead edge positions to the extremity of the body |

Notes:

1. Controlling parameter: inches.
2. Parameter "e1" ("e") is non-cumulative.
3. Seating plane (standoff) is defined by board hole size.
4. Parameter "B1" is nominal.
5. Details of pin Number 1 identifier are optional.
6. Parameters "D + E1" do not include mold flash/protrusions.
Mold flash or protrusions shall not exceed .010 inches.

PIC16C55X(A)

11.2 18-Lead Plastic Dual In-line (300 mil)

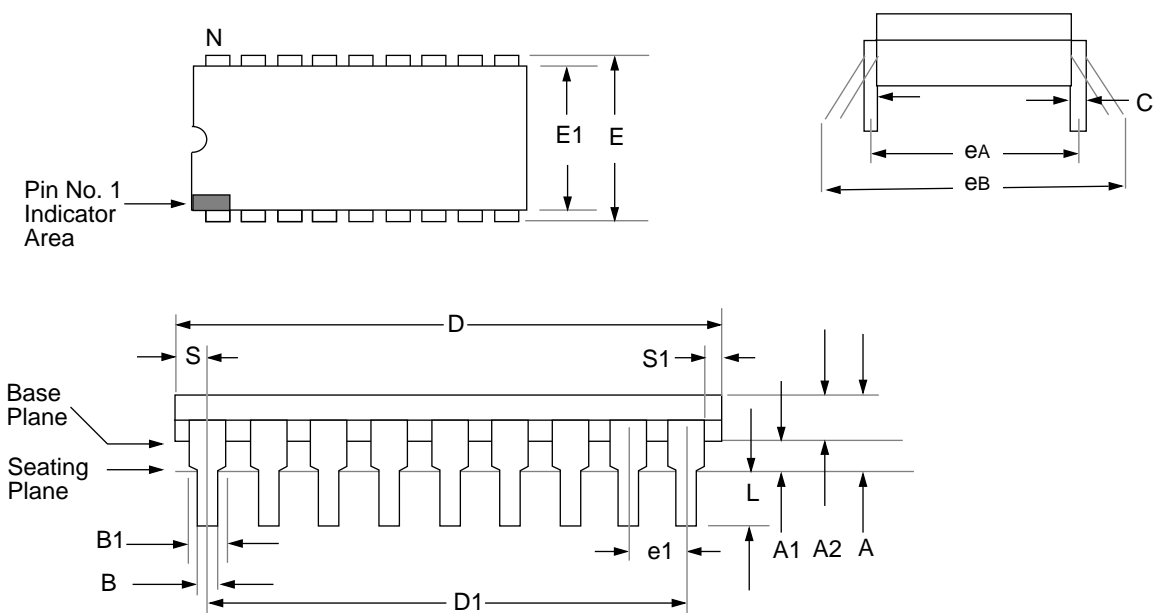

| Package Group: Plastic Dual In-Line (PLA) | | | | | | |
|---|-------------|--------|-----------|--------|-------|-----------|
| Symbol | Millimeters | | | Inches | | |
| | Min | Max | Notes | Min | Max | Notes |
| A | – | 4.064 | | – | 0.160 | |
| A1 | 0.381 | – | | 0.015 | – | |
| A2 | 3.048 | 3.810 | | 0.120 | 0.150 | |
| B | 0.355 | 0.559 | | 0.014 | 0.022 | |
| B1 | 1.524 | 1.524 | Reference | 0.060 | 0.060 | Reference |
| C | 0.203 | 0.381 | Typical | 0.008 | 0.015 | Typical |
| D | 22.479 | 23.495 | | 0.885 | 0.925 | |
| D1 | 20.320 | 20.320 | Reference | 0.800 | 0.800 | Reference |
| E | 7.620 | 8.255 | | 0.300 | 0.325 | |
| E1 | 6.096 | 7.112 | | 0.240 | 0.280 | |
| e1 | 2.489 | 2.591 | Typical | 0.098 | 0.102 | Typical |
| eA | 7.620 | 7.620 | Reference | 0.300 | 0.300 | Reference |
| eB | 8.128 | 9.906 | | 0.320 | 0.390 | |
| L | 3.048 | 3.556 | | 0.120 | 0.140 | |
| N | 18 | 18 | | 18 | 18 | |
| S | 0.889 | – | | 0.035 | – | |
| S1 | 0.127 | – | | 0.005 | – | |

Plastic Small Outline Family

| Symbol List for Small Outline Package Parameters | |
|--|--|
| Symbol | Description of Parameters |
| α | Angular spacing between min. and max. lead positions measured at the gauge plane |
| A | Distance between seating plane to highest point of body |
| A1 | Distance between seating plane and base plane |
| B | Width of terminals |
| C | Thickness of terminals |
| D | Largest overall package parameter of length |
| E | Largest overall package width parameter not including leads |
| e | Linear spacing of true minimum lead position center line to center line |
| H | Largest overall package dimension of width |
| L | Length of terminal for soldering to a substrate |
| N | Total number of potentially usable lead positions |
| CP | Seating plane coplanarity |

Notes:

1. Controlling parameter: inches.
2. All packages are gull wing lead form.
3. "D" and "E" are reference datums and do not include mold flash or protrusions. Mold flash or protrusions shall not exceed .006 package ends and .010 on sides.
4. The chamfer on the body is optional. If it is not present, a visual index feature must be located within the cross-hatched area to indicate pin 1 position.
5. Terminal numbers are shown for reference.

PIC16C55X(A)

11.3 18-Lead Plastic Surface Mount (SOIC - Wide, 300 mil Body)

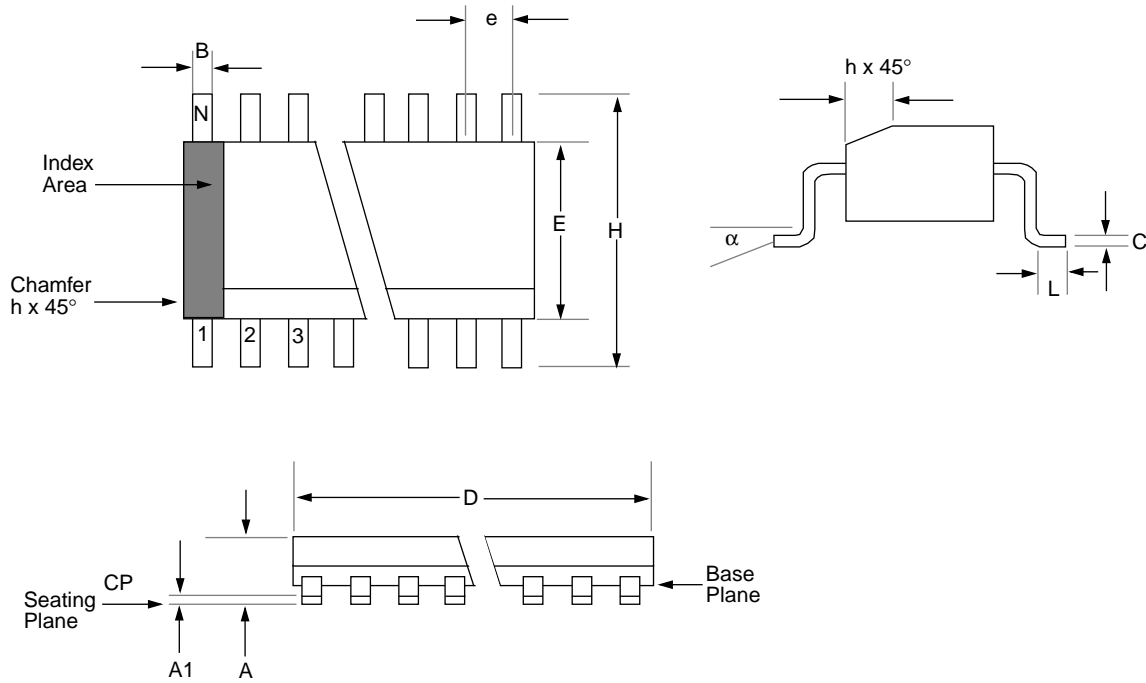

| Package Group: Plastic SOIC (SO) | | | | | | |
|----------------------------------|-------------|--------|-----------|--------|-------|-----------|
| Symbol | Millimeters | | | Inches | | |
| | Min | Max | Notes | Min | Max | Notes |
| α | 0° | 8° | | 0° | 8° | |
| A | 2.362 | 2.642 | | 0.093 | 0.104 | |
| A1 | 0.101 | 0.300 | | 0.004 | 0.012 | |
| B | 0.355 | 0.483 | | 0.014 | 0.019 | |
| C | 0.241 | 0.318 | | 0.009 | 0.013 | |
| D | 11.353 | 11.735 | | 0.447 | 0.462 | |
| E | 7.416 | 7.595 | | 0.292 | 0.299 | |
| e | 1.270 | 1.270 | Reference | 0.050 | 0.050 | Reference |
| H | 10.007 | 10.643 | | 0.394 | 0.419 | |
| h | 0.381 | 0.762 | | 0.015 | 0.030 | |
| L | 0.406 | 1.143 | | 0.016 | 0.045 | |
| N | 18 | 18 | | 18 | 18 | |
| CP | — | 0.102 | | — | 0.004 | |

11.4 20-Lead Plastic Surface Mount (SSOP - 209 mil Body 5.30 mm)

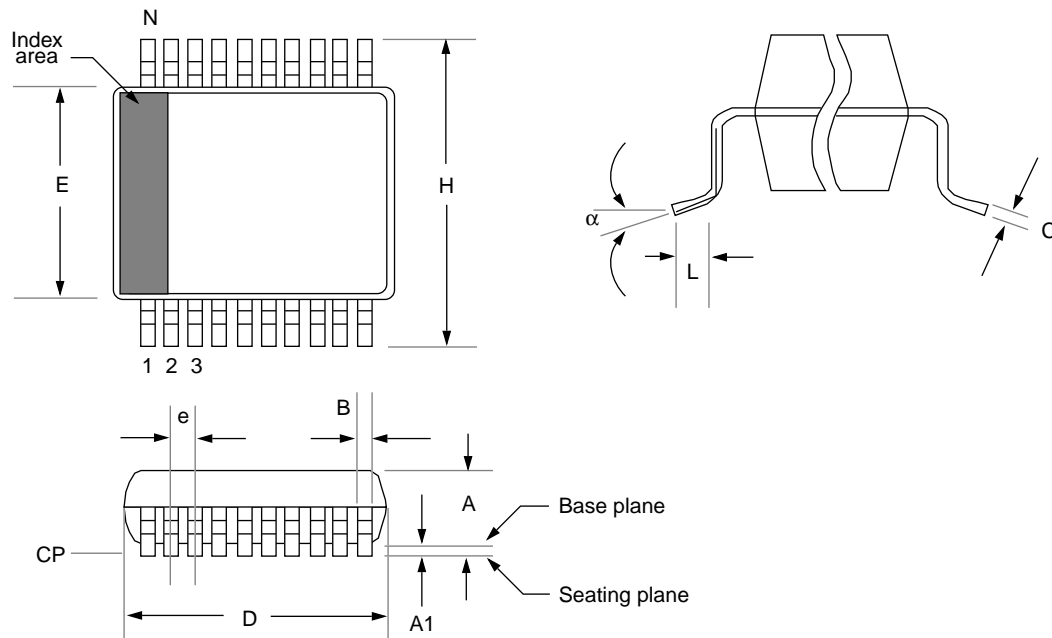

| Package Group: Plastic SSOP | | | | | | |
|-----------------------------|-------------|-------|-----------|--------|-------|-----------|
| Symbol | Millimeters | | | Inches | | |
| | Min | Max | Notes | Min | Max | Notes |
| α | 0° | 8° | | 0° | 8° | |
| A | 1.730 | 1.990 | | 0.068 | 0.078 | |
| A1 | 0.050 | 0.210 | | 0.002 | 0.008 | |
| B | 0.250 | 0.380 | | 0.010 | 0.015 | |
| C | 0.130 | 0.220 | | 0.005 | 0.009 | |
| D | 7.070 | 7.330 | | 0.278 | 0.289 | |
| E | 5.200 | 5.380 | | 0.205 | 0.212 | |
| e | 0.650 | 0.650 | Reference | 0.026 | 0.026 | Reference |
| H | 7.650 | 7.900 | | 0.301 | 0.311 | |
| L | 0.550 | 0.950 | | 0.022 | 0.037 | |
| N | 20 | 20 | | 20 | 20 | |
| CP | - | 0.102 | | - | 0.004 | |

PIC16C55X(A)

11.5 Package Marking Information

18-Lead PDIP

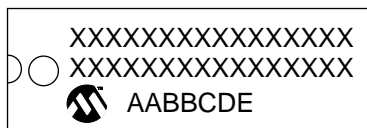

Example

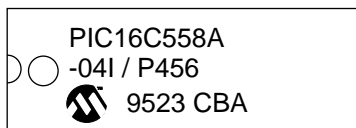

18-Lead SOIC (.300")

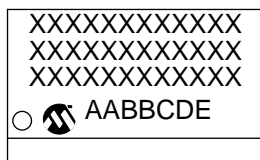

Example

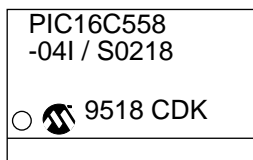

18-Lead CERDIP Windowed

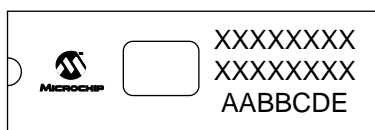

Example

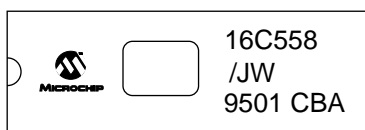

20-Lead SSOP

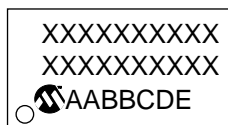

Example

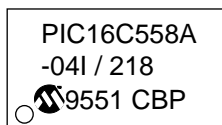

Legend: MM...M Microchip part number information
 XX...X Customer specific information*
 AA Year code (last 2 digits of calendar year)
 BB Week code (week of January 1 is week '01')
 C Facility code of the plant at which wafer is manufactured
 C = Chandler, Arizona, U.S.A.
 D Mask revision number
 E Assembly code of the plant or country of origin in which part was assembled

Note: In the event the full Microchip part number cannot be marked on one line, it will be carried over to the next line thus limiting the number of available characters for customer specific information.

* Standard OTP marking consists of Microchip part number, year code, week code, facility code, mask rev#, and assembly code. For OTP marking beyond this, certain price adders apply. Please check with your Microchip Sales Office. For QTP devices, any special marking adders are included in QTP price.

APPENDIX A: ENHANCEMENTS

The following are the list of enhancements over the PIC16C5X microcontroller family:

1. Instruction word length is increased to 14 bits. This allows larger page sizes both in program memory (4K now as opposed to 512 before) and register file (up to 128 bytes now versus 32 bytes before).
2. A PC high latch register (PCLATH) is added to handle program memory paging. PA2, PA1, PA0 bits are removed from STATUS register.
3. Data memory paging is slightly redefined. STATUS register is modified.
4. Four new instructions have been added: RETURN, RETFIE, ADDLW, and SUBLW. Two instructions TRIS and OPTION are being phased out although they are kept for compatibility with PIC16C5X.
5. OPTION and TRIS registers are made addressable.
6. Interrupt capability is added. Interrupt vector is at 0004h.
7. Stack size is increased to 8 deep.
8. Reset vector is changed to 0000h.
9. Reset of all registers is revised. Three different reset (and wake-up) types are recognized. Registers are reset differently.
10. Wake up from SLEEP through interrupt is added.
11. Two separate timers, Oscillator Start-up Timer (OST) and Power-up Timer (PWRT) are included for more reliable power-up. These timers are invoked selectively to avoid unnecessary delays on power-up and wake-up.
12. PORTB has weak pull-ups and interrupt on change feature.
13. Timer0 clock input, T0CKI pin is also a port pin (RA4/T0CKI) and has a TRIS bit.
14. FSR is made a full 8-bit register.
15. "In-circuit programming" is made possible. The user can program PIC16C55X devices using only five pins: VDD, VSS, VPP, RB6 (clock) and RB7 (data in/out).
16. PCON status register is added with a Power-on-Reset ($\overline{\text{POR}}$) status bit.
17. Code protection scheme is enhanced such that portions of the program memory can be protected, while the remainder is unprotected.
18. PORTA inputs are now Schmitt Trigger inputs.

APPENDIX B: COMPATIBILITY

To convert code written for PIC16C5X to PIC16C55X(A), the user should take the following steps:

1. Remove any program memory page select operations (PA2, PA1, PA0 bits) for CALL, GOTO.
2. Revisit any computed jump operations (write to PC or add to PC, etc.) to make sure page bits are set properly under the new scheme.
3. Eliminate any data memory page switching. Redefine data variables to reallocate them.
4. Verify all writes to STATUS, OPTION, and FSR registers since these have changed.
5. Change reset vector to 0000h.

PIC16C55X(A)

NOTES:

INDEX

A

| | |
|------------------------------|----|
| ADDLW Instruction | 53 |
| ADDWF Instruction | 53 |
| ANDLW Instruction | 53 |
| ANDWF Instruction | 53 |
| Architectural Overview | 9 |
| Assembler | |
| MPASM Assembler | 64 |

B

| | |
|--------------------------|----|
| BCF Instruction | 54 |
| Block Diagram | |
| TIMER0 | 29 |
| TMR0/WDT PRESCALER | 32 |
| BSF Instruction | 54 |
| BTFSC Instruction | 54 |
| BTFSS Instruction | 55 |

C

| | |
|---|----|
| CALL Instruction | 55 |
| Clocking Scheme/Instruction Cycle | 12 |
| CLRF Instruction | 55 |
| CLRW Instruction | 55 |
| CLRWDT Instruction | 56 |
| Code Protection | 50 |
| COMF Instruction | 56 |
| Configuration Bits | 36 |

D

| | |
|--------------------------------|----|
| Data Memory Organization | 14 |
| DECF Instruction | 56 |
| DECFSZ Instruction | 56 |
| Development Support | 63 |
| Development Tools | 63 |

E

| | |
|---|----|
| External Crystal Oscillator Circuit | 38 |
|---|----|

F

| | |
|--|----|
| Fuzzy Logic Dev. System (<i>fuzzyTECH</i> ®-MP) | 65 |
|--|----|

G

| | |
|-------------------------------------|----|
| General purpose Register File | 14 |
| GOTO Instruction | 57 |

I

| | |
|---|----|
| I/O Ports | 23 |
| I/O Programming Considerations | 27 |
| ICEPIC Low-Cost PIC16CXXX In-Circuit Emulator | 63 |
| ID Locations | 50 |
| INCF Instruction | 57 |
| INCFSZ Instruction | 57 |
| In-Circuit Serial Programming | 50 |
| Indirect Addressing, INDF and FSR Registers | 22 |
| Instruction Flow/Pipelining | 12 |
| Instruction Set | |

| | |
|--------------|----|
| ADDLW | 53 |
| ADDWF | 53 |
| ANDLW | 53 |
| ANDWF | 53 |
| BCF | 54 |
| BSF | 54 |
| BTFSC | 54 |
| BTFSS | 55 |
| CALL | 55 |
| CLRF | 55 |
| CLRW | 55 |
| CLRWDT | 56 |

| | |
|--------------|----|
| COMF | 56 |
| DECF | 56 |
| DECFSZ | 56 |
| GOTO | 57 |
| INCF | 57 |
| INCFSZ | 57 |
| IORLW | 57 |
| IORWF | 58 |
| MOVF | 58 |
| MOVLW | 58 |
| MOVWF | 58 |
| NOP | 59 |
| OPTION | 59 |
| RETFIE | 59 |
| RETLW | 59 |
| RETURN | 60 |
| RLF | 60 |
| RRF | 60 |
| SLEEP | 60 |
| SUBLW | 61 |
| SUBWF | 61 |
| SWAPF | 62 |
| TRIS | 62 |
| XORLW | 62 |
| XORWF | 62 |

| | |
|-------------------------------|----|
| Instruction Set Summary | 51 |
| INT Interrupt | 46 |
| INTCON Register | 19 |
| Interrupts | 45 |
| IORLW Instruction | 57 |
| IORWF Instruction | 58 |

K

| | |
|--|----|
| KeeLoq® Evaluation and Programming Tools | 65 |
|--|----|

M

| | |
|---|----|
| MOVF Instruction | 58 |
| MOVLW Instruction | 58 |
| MOVWF Instruction | 58 |
| MP-DriveWay™ - Application Code Generator | 65 |
| MPLAB C | 65 |
| MPLAB Integrated Development Environment Software | 64 |

N

| | |
|-----------------------|----|
| NOP Instruction | 59 |
|-----------------------|----|

O

| | |
|---|----|
| One-Time-Programmable (OTP) Devices | 7 |
| OPTION Instruction | 59 |
| OPTION Register | 18 |
| Oscillator Configurations | 37 |
| Oscillator Start-up Timer (OST) | 40 |

P

| | |
|---|----|
| Package Marking Information | 86 |
| Packaging Information | 79 |
| PCL and PCLATH | 21 |
| PCON Register | 20 |
| PICDEM-1 Low-Cost PICmicro Demo Board | 64 |
| PICDEM-2 Low-Cost PIC16CXX Demo Board | 64 |
| PICDEM-3 Low-Cost PIC16CXXX Demo Board | 64 |
| PICMASTER® In-Circuit Emulator | 63 |
| PICSTART® Plus Entry Level Development System | 63 |
| Pinout Description | 11 |
| Port RB Interrupt | 46 |
| PORTA | 23 |
| PORTB | 25 |
| Power Control/Status Register (PCON) | 41 |
| Power-Down Mode (SLEEP) | 49 |

PIC16C55X(A)

| | |
|--|----|
| Power-On Reset (POR) | 40 |
| Power-up Timer (PWRT)..... | 40 |
| Prescaler | 32 |
| PRO MATE® II Universal Programmer..... | 63 |
| Program Memory Organization | 13 |

Q

| | |
|---|---|
| Quick-Turnaround-Production (QTP) Devices | 7 |
|---|---|

R

| | |
|-------------------------|----|
| RC Oscillator | 38 |
| Reset..... | 39 |
| RETFIE Instruction..... | 59 |
| RETLW Instruction..... | 59 |
| RETURN Instruction..... | 60 |
| RLF Instruction..... | 60 |
| RRF Instruction | 60 |

S

| | |
|---|----|
| SEEVAL® Evaluation and Programming System | 65 |
| Serialized Quick-Turnaround-Production (SQTP) Devices ... | 7 |
| SLEEP Instruction | 60 |
| Software Simulator (MPLAB-SIM)..... | 65 |
| Special Features of the CPU..... | 35 |
| Special Function Registers | 16 |
| Stack | 21 |
| Status Register..... | 17 |
| SUBLW Instruction..... | 61 |
| SUBWF Instruction..... | 61 |
| SWAPF Instruction..... | 62 |

T

| | |
|---|----|
| Timer0 | |
| TIMER0..... | 29 |
| TIMER0 (TMR0) Interrupt | 29 |
| TIMER0 (TMR0) Module..... | 29 |
| TMR0 with External Clock..... | 31 |
| Timer1 | |
| Switching Prescaler Assignment..... | 33 |
| Timing Diagrams and Specifications..... | 74 |
| TMR0 Interrupt | 46 |
| TRIS Instruction | 62 |
| TRISA..... | 23 |
| TRISB..... | 25 |

W

| | |
|----------------------------|----|
| Watchdog Timer (WDT) | 47 |
|----------------------------|----|

X

| | |
|-------------------------|----|
| XORLW Instruction | 62 |
| XORWF Instruction | 62 |

LIST OF EXAMPLES

| | |
|--|----|
| Example 3-1: Instruction Pipeline Flow | 12 |
| Example 4-1: Ndirect Addressing..... | 22 |
| Example 5-1: Read-Modify-Write Instructions on an I/O Port..... | 27 |
| Example 6-1: Changing Prescaler (Timer0→WDT)..... | 33 |
| Example 6-2: Changing prescaler (WDT→Timer0)..... | 33 |
| Example 7-1: Saving the Status and W Registers in RAM | 47 |

LIST OF FIGURES

| | |
|--|----|
| Figure 3-1: Block Diagram | 10 |
| Figure 3-2: Clock/Instruction Cycle | 12 |
| Figure 4-1: Program Memory Map and Stack for the PIC16C554/PIC6C554(A) | 13 |
| Figure 4-2: Program Memory Map and Stack for the PIC16C556(A) | 13 |
| Figure 4-3: Program Memory Map and Stack for the PIC16C558/PIC16C558(A) | 13 |
| Figure 4-4: Data Memory Map for the PIC16C554/554(A) | 15 |
| Figure 4-5: Data Memory Map for the PIC16C558/558(A) | 15 |
| Figure 4-6: STATUS Register (Address 03h or 83h) | 17 |
| Figure 4-7: OPTION Register (address 81h) | 18 |
| Figure 4-8: INTCON Register (address 0Bh or 8Bh)..... | 19 |
| Figure 4-9: PCON Register (Address 8Eh)..... | 20 |
| Figure 4-10: Loading Of PC In Different Situations | 21 |
| Figure 4-11: Direct/indirect Addressing PIC16C55X(A)..... | 22 |
| Figure 5-1: Block Diagram of PORT pins RA<3:0>..... | 23 |
| Figure 5-2: Block Diagram of RA4 Pin..... | 23 |
| Figure 5-3: Block Diagram of RB7:RB4 Pins | 25 |
| Figure 5-4: Block Diagram of RB3:RB0 Pins | 25 |
| Figure 5-5: Successive I/O Operation..... | 27 |
| Figure 6-1: TIMER0 Block Diagram | 29 |
| Figure 6-2: TIMER0 (TMR0) Timing: Internal Clock/No PrescaleR | 29 |
| Figure 6-3: TIMER0 Timing: Internal Clock/ Prescale 1:2 | 30 |
| Figure 6-4: TIMER0 Interrupt Timing | 30 |
| Figure 6-5: TIMER0 Timing With External Clock | 31 |
| Figure 6-6: Block Diagram of the Timer0/WDT Prescaler | 32 |
| Figure 7-1: Configuration Word | 36 |
| Figure 7-2: Crystal Operation (or Ceramic Resonator) (HS, XT or LP Osc Configuration) | 37 |
| Figure 7-3: External Clock Input Operation (HS, XT or LP Osc Configuration) | 37 |
| Figure 7-4: External Parallel Resonant Crystal Oscillator Circuit | 38 |
| Figure 7-5: External Series Resonant Crystal Oscillator Circuit | 38 |
| Figure 7-6: RC Oscillator Mode | 38 |
| Figure 7-7: Simplified Block Diagram of On-chip Reset Circuit..... | 39 |
| Figure 7-8: Time-out Sequence on Power-up (MCLR not tied to VDD): Case 1 | 43 |
| Figure 7-9: Time-out Sequence on Power-up (MCLR not tied to VDD): Case 2 | 43 |
| Figure 7-10: Time-out Sequence on Power-up (MCLR tied to VDD)..... | 43 |
| Figure 7-11: External Power-on Reset Circuit (For Slow VDD Power-up)..... | 44 |
| Figure 7-12: Interrupt Logic | 45 |
| Figure 7-13: INT Pin Interrupt Timing | 46 |
| Figure 7-14: Watchdog Timer Block Diagram..... | 48 |
| Figure 7-15: Summary of Watchdog Timer Registers | 48 |
| Figure 7-16: Wake-up from Sleep Through Interrupt..... | 49 |
| Figure 7-17: Typical In-Circuit Serial Programming Connection | 50 |

| | | |
|--------------|---|----|
| Figure 8-1: | General Format for Instructions | 51 |
| Figure 10-1: | Load Conditions..... | 73 |
| Figure 10-2: | External Clock Timing..... | 74 |
| Figure 10-3: | CLKOUT and I/O Timing..... | 75 |
| Figure 10-4: | Reset, Watchdog Timer, Oscillator Start-Up Timer and Power-Up Timer Timing..... | 76 |
| Figure 10-5: | TIMER0 Clock Timing..... | 77 |
| Figure 10-6: | Load Conditions..... | 77 |

LIST OF TABLES

| | | |
|-------------|---|----|
| Table 1-1: | PIC16C55X(A) Family of Devices..... | 6 |
| Table 3-1: | PIC16C55X(A) Pinout Description | 11 |
| Table 4-1: | Special Registers for the PIC16C55X(A) | 16 |
| Table 5-1: | PORTA Functions | 24 |
| Table 5-2: | Summary of Registers Associated With PORTA | 24 |
| Table 5-3: | PORTB Functions | 26 |
| Table 5-4: | Summary of Registers Associated with PORTB | 26 |
| Table 6-1: | Registers Associated with Timer0..... | 33 |
| Table 7-1: | Capacitor Selection for Ceramic Resonators (Preliminary) | 37 |
| Table 7-2: | Capacitor Selection for Crystal Oscillator (Preliminary)..... | 37 |
| Table 7-3: | Time-out in Various Situations..... | 41 |
| Table 7-4: | StatUs Bits and Their Significance..... | 41 |
| Table 7-5: | Initialization Condition for Special Registers..... | 42 |
| Table 7-6: | Initialization Condition for Registers..... | 42 |
| Table 8-1: | OPCODE Field Descriptions..... | 51 |
| Table 8-2: | PIC16C55X(A) Instruction SeT | 52 |
| Table 9-1: | Development Tools From Microchip | 66 |
| Table 10-1: | Cross Reference of Device Specs for Oscillator Configurations and Frequencies of Operation (Commercial Devices)..... | 67 |
| Table 10-2: | External Clock Timing Requirements..... | 74 |
| Table 10-3: | CLKOUT and I/O Timing Requirements..... | 75 |
| Table 10-4: | Reset, Watchdog Timer, Oscillator Start-up Timer and Power-up Timer Requirements..... | 76 |
| Table 10-5: | TIMER0 Clock Requirements | 77 |

PIC16C55X(A)

NOTES:

ON-LINE SUPPORT

Microchip provides two methods of on-line support. These are the Microchip BBS and the Microchip World Wide Web (WWW) site.

Use Microchip's Bulletin Board Service (BBS) to get current information and help about Microchip products. Microchip provides the BBS communication channel for you to use in extending your technical staff with microcontroller and memory experts.

To provide you with the most responsive service possible, the Microchip systems team monitors the BBS, posts the latest component data and software tool updates, provides technical help and embedded systems insights, and discusses how Microchip products provide project solutions.

The web site, like the BBS, is used by Microchip as a means to make files and information easily available to customers. To view the site, the user must have access to the Internet and a web browser, such as Netscape or Microsoft Explorer. Files are also available for FTP download from our FTP site.

Connecting to the Microchip Internet Web Site

The Microchip web site is available by using your favorite Internet browser to attach to:

www.microchip.com

The file transfer site is available by using an FTP service to connect to:

[ftp.mchip.com/biz/mchip](ftp://mchip.com/biz/mchip)

The web site and file transfer site provide a variety of services. Users may download files for the latest Development Tools, Data Sheets, Application Notes, User's Guides, Articles and Sample Programs. A variety of Microchip specific business information is also available, including listings of Microchip sales offices, distributors and factory representatives. Other data available for consideration is:

- Latest Microchip Press Releases
- Technical Support Section with Frequently Asked Questions
- Design Tips
- Device Errata
- Job Postings
- Microchip Consultant Program Member Listing
- Links to other useful web sites related to Microchip Products

Connecting to the Microchip BBS

Connect worldwide to the Microchip BBS using either the Internet or the CompuServe® communications network.

Internet:

You can telnet or ftp to the Microchip BBS at the address:

[mchipbbs.microchip.com](telnet://mchipbbs.microchip.com)

CompuServe Communications Network:

When using the BBS via the CompuServe Network, in most cases, a local call is your only expense. The Microchip BBS connection does not use CompuServe membership services, therefore you do not need CompuServe membership to join Microchip's BBS. There is no charge for connecting to the Microchip BBS.

The procedure to connect will vary slightly from country to country. Please check with your local CompuServe agent for details if you have a problem. CompuServe service allow multiple users various baud rates depending on the local point of access.

The following connect procedure applies in most locations.

1. Set your modem to 8-bit, No parity, and One stop (8N1). This is not the normal CompuServe setting which is 7E1.
2. Dial your local CompuServe access number.
3. Depress the <Enter> key and a garbage string will appear because CompuServe is expecting a 7E1 setting.
4. Type +, depress the <Enter> key and "Host Name:" will appear.
5. Type MCHIPBBS, depress the <Enter> key and you will be connected to the Microchip BBS.

In the United States, to find the CompuServe phone number closest to you, set your modem to 7E1 and dial (800) 848-4480 for 300-2400 baud or (800) 331-7166 for 9600-14400 baud connection. After the system responds with "Host Name:", type NETWORK, depress the <Enter> key and follow CompuServe's directions.

For voice information (or calling from overseas), you may call (614) 723-1550 for your local CompuServe number.

Microchip regularly uses the Microchip BBS to distribute technical information, application notes, source code, errata sheets, bug reports, and interim patches for Microchip systems software products. For each SIG, a moderator monitors, scans, and approves or disapproves files submitted to the SIG. No executable files are accepted from the user community in general to limit the spread of computer viruses.

Systems Information and Upgrade Hot Line

The Systems Information and Upgrade Line provides system users a listing of the latest versions of all of Microchip's development systems software products. Plus, this line provides information on how customers can receive any currently available upgrade kits. The Hot Line Numbers are:

- 1-800-755-2345 for U.S. and most of Canada, and
- 1-602-786-7302 for the rest of the world.

960513

Trademarks: The Microchip name, logo, PIC, PICSTART, PICMASTER, PRO MATE and In-Circuit Serial Programming are registered trademarks of Microchip Technology Incorporated in the U.S.A. and other countries. PICmicro, FlexROM, MPLAB, and fuzzyLAB, are trademarks and SQTP is a service mark of Microchip in the U.S.A.

fuzzyTECH is a registered trademark of Inform Software Corporation. IBM, IBM PC-AT are registered trademarks of International Business Machines Corp. Pentium is a trademark of Intel Corporation. Windows is a trademark and MS-DOS, Microsoft Windows are registered trademarks of Microsoft Corporation. CompuServe is a registered trademark of CompuServe Incorporated.

All other trademarks mentioned herein are the property of their respective companies.

PIC16C55X(A)

READER RESPONSE

It is our intention to provide you with the best documentation possible to ensure successful use of your Microchip product. If you wish to provide your comments on organization, clarity, subject matter, and ways in which our documentation can better serve you, please FAX your comments to the Technical Publications Manager at (602) 786-7578.

Please list the following information, and use this outline to provide us with your comments about this Data Sheet.

To: Technical Publications Manager Total Pages Sent _____

RE: Reader Response

From: Name _____

Company _____

Address _____

City / State / ZIP / Country _____

Telephone: (_____) _____ - _____ FAX: (_____) _____ - _____

Application (optional):

Would you like a reply? ___Y ___N

Device: **PIC16C55X(A)** Literature Number: **DS40143B**

Questions:

1. What are the best features of this document?

2. How does this document meet your hardware and software development needs?

3. Do you find the organization of this data sheet easy to follow? If not, why?

4. What additions to the data sheet do you think would enhance the structure and subject?

5. What deletions from the data sheet could be made without affecting the overall usefulness?

6. Is there any incorrect or misleading information (what and where)?

7. How would you improve this document?

8. How would you improve our software, systems, and silicon products?

PIC16C55X(A) Product Identification System

To order or to obtain information, e.g., on pricing or delivery, please use the listed part numbers, and refer to the factory or the listed sales offices.

| PART NO. | -XX | X | /XX | XXX | |
|----------|-----|---|-----|-----|--|
| | | | | | Pattern: 3-Digit Pattern Code for QTP (blank otherwise) |
| | | | | | Package: P = PDIP SO = SOIC (Gull Wing, 300 mil body) SS = SSOP (209 mil) JW* = Windowed CERDIP |
| | | | | | Temperature Range: - = 0°C to +70°C I = -40°C to +85°C E = -40°C to +125°C |
| | | | | | Frequency Range: 04 = 200kHz (LP osc) 04 = 4 MHz (XT and RC osc) 20 = 20 MHz (HS osc) |
| | | | | | Device: PIC16C55X :VDD range 3.0V to 5.5V PIC16C55XT:VDD range 3.0V to 5.5V (Tape and Reel) PIC16C55XA: VDD range 3.0V to 5.5V PIC16C55XAT: VDD range 3.0V to 5.5V (Tape and Reel) PIC16LC55X:VDD range 2.5V to 5.5V PIC16LC55XT:VDD range 2.5V to 5.5V (Tape and Reel) |
| | | | | | Examples: f) PIC16C554A - 04/P 301 = Commercial temp., PDIP package, 4 MHz, normal VDD limits, QTP pattern #301. g) PIC16LC558- 04I/SO = Industrial temp., SOIC package, 200kHz, extended VDD limits. |

* JW Devices are UV erasable and can be programmed to any device configuration. JW Devices meet the electrical requirement of each oscillator type (including LC devices).

Sales and Support

Products supported by a preliminary Data Sheet may possibly have an errata sheet describing minor operational differences and recommended workarounds. To determine if an errata sheet exists for a particular device, please contact one of the following:

1. Your local Microchip sales office (see below)
2. The Microchip Corporate Literature Center U.S. FAX: (602) 786-7277
3. The Microchip's Bulletin Board, via your local CompuServe number (CompuServe membership NOT required).

Please specify which device, revision of silicon and Data Sheet (include Literature #) you are using.

For latest version information and upgrade kits for Microchip Development Tools, please call 1-800-755-2345 or 1-602-786-7302.



MICROCHIP

WORLDWIDE SALES & SERVICE

AMERICAS

Corporate Office

Microchip Technology Inc.
2355 West Chandler Blvd.
Chandler, AZ 85224-6199
Tel: 602-786-7200 Fax: 602-786-7277
Technical Support: 602 786-7627
Web: <http://www.microchip.com>

Atlanta

Microchip Technology Inc.
500 Sugar Mill Road, Suite 200B
Atlanta, GA 30350
Tel: 770-640-0034 Fax: 770-640-0307

Boston

Microchip Technology Inc.
5 Mount Royal Avenue
Marlborough, MA 01752
Tel: 508-480-9990 Fax: 508-480-8575

Chicago

Microchip Technology Inc.
333 Pierce Road, Suite 180
Itasca, IL 60143
Tel: 630-285-0071 Fax: 630-285-0075

Dallas

Microchip Technology Inc.
14651 Dallas Parkway, Suite 816
Dallas, TX 75240-8809
Tel: 972-991-7177 Fax: 972-991-8588

Dayton

Microchip Technology Inc.
Two Prestige Place, Suite 150
Miamisburg, OH 45342
Tel: 937-291-1654 Fax: 937-291-9175

Los Angeles

Microchip Technology Inc.
18201 Von Karman, Suite 1090
Irvine, CA 92612
Tel: 714-263-1888 Fax: 714-263-1338

New York

Microchip Technology Inc.
150 Motor Parkway, Suite 416
Hauppauge, NY 11788
Tel: 516-273-5305 Fax: 516-273-5335

San Jose

Microchip Technology Inc.
2107 North First Street, Suite 590
San Jose, CA 95131
Tel: 408-436-7950 Fax: 408-436-7955

Toronto

Microchip Technology Inc.
5925 Airport Road, Suite 200
Mississauga, Ontario L4V 1W1, Canada
Tel: 905-405-6279 Fax: 905-405-6253

ASIA/PACIFIC

Hong Kong

Microchip Asia Pacific
RM 3801B, Tower Two
Metroplaza
223 Hing Fong Road
Kwai Fong, N.T., Hong Kong
Tel: 852-2-401-1200 Fax: 852-2-401-3431

India

Microchip Technology Inc.
India Liaison Office
No. 6, Legacy, Convent Road
Bangalore 560 025, India
Tel: 91-80-229-4036 Fax: 91-80-559-9840

Korea

Microchip Technology Korea
168-1, Youngbo Bldg. 3 Floor
Samsung-Dong, Kangnam-Ku
Seoul, Korea
Tel: 82-2-554-7200 Fax: 82-2-558-5934

Shanghai

Microchip Technology
RM 406 Shanghai Golden Bridge Bldg.
2077 Yan'an Road West, Hong Qiao District
Shanghai, PRC 200335
Tel: 86-21-6275-5700
Fax: 86 21-6275-5060

Singapore

Microchip Technology Taiwan
Singapore Branch
200 Middle Road
#07-02 Prime Centre
Singapore 188980
Tel: 65-334-8870 Fax: 65-334-8850

Taiwan, R.O.C

Microchip Technology Taiwan
10F-1C 207
Tung Hua North Road
Taipei, Taiwan, ROC
Tel: 886 2-717-7175 Fax: 886-2-545-0139

EUROPE

United Kingdom

Arizona Microchip Technology Ltd.
Unit 6, The Courtyard
Meadow Bank, Furlong Road
Bourne End, Buckinghamshire SL8 5AJ
Tel: 44-1628-851077 Fax: 44-1628-850259

France

Arizona Microchip Technology SARL
Zone Industrielle de la Bonde
2 Rue du Buisson aux Fraises
91300 Massy, France
Tel: 33-1-69-53-63-20 Fax: 33-1-69-30-90-79

Germany

Arizona Microchip Technology GmbH
Gustav-Heinemann-Ring 125
D-81739 München, Germany
Tel: 49-89-627-144 0 Fax: 49-89-627-144-44

Italy

Arizona Microchip Technology SRL
Centro Direzionale Colleoni
Palazzo Taurus 1 V. Le Colleoni 1
20041 Agrate Brianza
Milan, Italy
Tel: 39-39-6899939 Fax: 39-39-6899883

JAPAN

Microchip Technology Intl. Inc.
Benex S-1 6F
3-18-20, Shinyokohama
Kohoku-Ku, Yokohama-shi
Kanagawa 222 Japan
Tel: 81-45-471- 6166 Fax: 81-45-471-6122

8/29/97



All rights reserved. © 1997, Microchip Technology Incorporated, USA. 9/97 Printed on recycled paper.

Information contained in this publication regarding device applications and the like is intended for suggestion only and may be superseded by updates. No representation or warranty is given and no liability is assumed by Microchip Technology Incorporated with respect to the accuracy or use of such information, or infringement of patents or other intellectual property rights arising from such use or otherwise. Use of Microchip's products as critical components in life support systems is not authorized except with express written approval by Microchip. No licenses are conveyed, implicitly or otherwise, under any intellectual property rights. The Microchip logo and name are registered trademarks of Microchip Technology Inc. in the U.S.A. and other countries. All rights reserved. All other trademarks mentioned herein are the property of their respective companies.

Copyright © Each Manufacturing Company.

All Datasheets cannot be modified without permission.

This datasheet has been download from :

www.AllDataSheet.com

100% Free DataSheet Search Site.

Free Download.

No Register.

Fast Search System.

www.AllDataSheet.com