



June 1999

LM3620 Lithium-Ion Battery Charger Controller

General Description

The LM3620 series of controllers are monolithic integrated circuits designed to control the charging and end-of-charge control for lithium-ion rechargeable batteries. The LM3620 is available in two versions for one or two cell charger applications. Each version provides the option of selecting the appropriate termination voltage for either coke or graphite anode lithium cells.

The LM3620 can operate from a wide range of DC input sources (4V to 30V). With no charger supply connected, the controller draws a quiescent current of only 10nA to minimize discharging of a connected battery pack.

The LM3620 consists of an operational transconductance amplifier, a bandgap voltage reference, a NPN driver transistor and precision voltage setting resistors. The output of the amplifier is made available to drive an external power transistor if higher drive currents are required.

With a trimmed output voltage regulation of $\pm 1.2\%$ initial accuracy, the LM3620 provides a simple, precise solution for end-of-charge control of lithium-ion rechargeable cells.

The LM3620 is packaged in a miniature 5-lead SOT-23 surface mount package for very compact designs.

Features

- Voltage options for charging 1 or 2 cell stacks
- Adjustable output voltage for coke or graphite anodes
- Precision end-of-charge voltage control
- Wide input voltage range (4V to 30V)
- Low off state current (<10nA)
- Drive provided for external power stage
- Tiny SOT-23 package

Typical Application

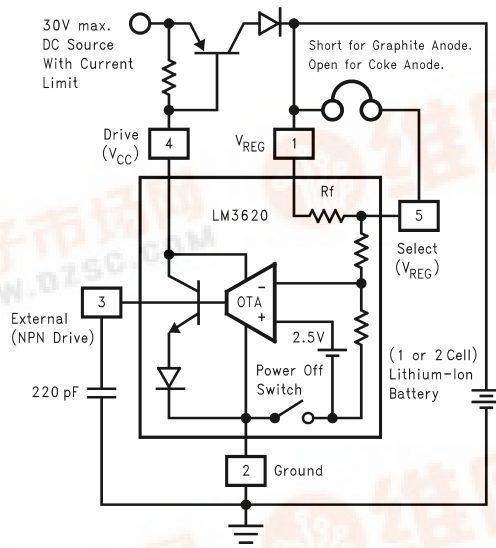

LM3620 Lithium-Ion Battery Charger Controller



Connection Diagram

5-Lead SOT23-5 Surface Mount Package

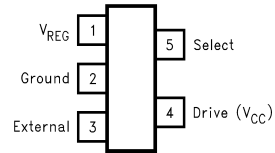

DS100841-1

Refer to the Ordering Information Table in this Data Sheet for Specific Part Number

See NS Package MA05B

Ordering Information

Device Order Number	Package Marking	Output Voltage	Initial Accuracy (25°C)	Over Temperature Accuracy (0 to 70°C)	Number of Cells	Supplied as
LM3620M5-4	D10B	4.1V/4.2V	1.2%	2%	1	250 Unit increments on Tape and Reel
LM3620M5X-4	D10B	4.1V/4.2V	1.2%	2%	1	3k Unit increments on Tape and Reel
LM3620M5-8	D11B	8.2V/8.4V	1.2%	2%	2	250 Unit increments on Tape and Reel
LM3620M5X-8	D11B	8.2V/8.4V	1.2%	2%	2	3k Unit increments on Tape and Reel

The small physical size of the SOT23-5 Package does not allow for the full part number marking. Devices will be marked with the designation shown in the column Package Marking.

The devices are shipped in tape-and-reel format. The standard quantity is 250 units on a reel (indicated by the letters "M5" in the part number), or 3000 units on a reel (indicated by the letters "M5X" in the part number).

Absolute Maximum Ratings (Note 1)

If Military/Aerospace specified devices are required, please contact the National Semiconductor Sales Office/ Distributors for availability and specifications.

Input Voltage (V_{DRIVE})	35V
V_{EXT}	1.5V
Junction Temperature	150°C
Storage Temperature	-65 to +150°C
Lead Temp. Soldering	
Vapor Phase (60 sec.)	215°C
Infrared (15 sec.)	220°C

Power Dissipation ($T_A = 25^\circ\text{C}$) (Note 2)

300mW

ESD Susceptibility (Note 3)

2000V

Operating Ratings (Note 1)

Ambient Temp. Range	0°C to 70°C
Junction Temp. Range	0°C to 125°C
Thermal Resistance (Junction to Ambient, θ_{J-A})	280°C/W
Input Voltage (V_{DRIVE})	4V to 30V

Electrical Characteristics

LM3620-4

$V_{DRIVE} = 5V$, $I_{DRIVE} = 2mA$. Limits with **boldface type** apply over the full operating ambient temperature range, 0°C to +70°C, limits with standard typeface apply for $T_A = 25^\circ\text{C}$.

Symbol	Parameter	Conditions	Typical	Limit	Units
V_{REG}	Regulated Output Voltage (pin 1 to ground)	Pin 5 shorted to pin 1 (graphite anode)	4.1	4.051/ 4.018	V(min)
		Pin 5 open (coke anode)	4.2	4.149/ 4.182	V(max)
	Regulated Output Voltage Tolerance	Either Pin 5 setting		4.150/ 4.116	V(min)
				4.250/ 4.284	V(max)
				$\pm 1.2/\pm 2.0$	%
V_{REG}/V_{DRIVE}	Supply Sensitivity	V_{REG} for $5V \leq V_{DRIVE} \leq 30V$	100		$\mu V/V(\text{max})$
I_Q	Quiescent Current	$V_{REG} = 4.5V$, $V_{EXT} = 1.0V$ (Note 4)	400	750	$\mu A(\text{max})$
I_{OFF}	Off State Current	V_{DRIVE} open circuited (Note 5)	10	200	nA(max)
I_{DRIVE}	Drive Pin Sink Current	$V_{DRIVE} = 5.0V$	20	15	mA(min)
$G_{M(DRIVE)}$	Drive Pin Transconductance	$\Delta I_{DRIVE}/\Delta V_{REG}$ $2mA \leq I_{DRIVE} \leq 15mA$	3		A/V
I_{EXT}	External Pin Source Current	$V_{EXT} = 1V$ (Note 6)	3	2.5	mA(min)
$G_{M(EXT)}$	External Pin Transconductance	$\Delta I_{EXT}/\Delta V_{REG}$, $V_{EXT} = 1V$ $0mA \leq I_{EXT} \leq 2.5mA$	0.8		A/V
R_{IN}	V_{REG} Input Resistance	Pin 1 to Ground.	46		k Ω
		Circuit biased with V_{DRIVE} applied V_{DRIVE} open circuited	42		M Ω
R_F	Feedback Resistance	Pin 1 to Pin 5	1500		Ω

LM3620-8

$V_{DRIVE} = 5V$, $I_{DRIVE} = 2mA$. Limits with **boldface type** apply over the full operating ambient temperature range, 0°C to +70°C, limits with standard typeface apply for $T_A = 25^\circ C$.

Symbol	Parameter	Conditions	Typical	Limit	Units	
V_{REG}	Regulated Output Voltage (pin 1 to ground)	Pin 5 shorted to pin 1 (graphite anode)	8.2	8.102/ 8.036	V(min)	
		Pin 5 open (coke anode)	8.4	8.298/ 8.364	V(max)	
	Regulated Output Voltage Tolerance	Either Pin 5 setting			8.299/ 8.232	V(min)
						8.501/ 8.568
				$\pm 1.2/\pm 2.0$	%	
V_{REG}/V_{DRIVE}	Supply Sensitivity	V_{REG} for $5V \leq V_{DRIVE} \leq 30V$	200		$\mu V/V(max)$	
I_Q	Quiescent Current	$V_{REG} = 8.7V$, $V_{EXT} = 1.0V$ (Note 4)	400	750	$\mu A(max)$	
I_{OFF}	Off State Current	V_{DRIVE} open circuited (Note 5)	10	200	nA(max)	
I_{DRIVE}	Drive Pin Sink Current	$V_{DRIVE} = 5.0V$	20	15	mA(min)	
$G_{m(DRIVE)}$	Drive Pin Transconductance	$\Delta I_{DRIVE}/\Delta V_{REG}$ $2mA \leq I_{DRIVE} \leq 15mA$	1.5		A/V	
I_{EXT}	External Pin Source Current	$V_{EXT} = 1V$ (Note 6)	3	2.5	mA(min)	
$G_{m(EXT)}$	External Pin Transconductance	$\Delta I_{EXT}/\Delta V_{REG}$, $V_{EXT} = 1V$ $0mA \leq I_{EXT} \leq 2.5mA$	0.4		A/V	
R_{IN}	V_{REG} Input Resistance	Pin 1 to Ground.	110		k Ω	
		Circuit biased with V_{DRIVE} applied V_{DRIVE} open circuited	42		M Ω	
R_F	Feedback Resistance	Pin 1 to Pin 5	2900		Ω	

Note 1: Absolute Maximum Ratings indicate limits beyond which damage to the device may occur. Operating Ratings indicate conditions for which the device is intended to be functional, but do not guarantee specific performance limits. For guaranteed specifications and test conditions, see the Electrical Characteristics.

Note 2: The maximum power dissipation must be derated at elevated temperatures and is limited by T_{JMAX} (maximum junction temperature), θ_{J-A} (junction-to-ambient thermal resistance) and T_A (ambient temperature). The maximum power dissipation at any temperature is: $PD_{ISMAX} = (T_{JMAX} - T_A)/\theta_{J-A}$ up to the value listed in the Absolute Maximum Ratings.

Note 3: Rating is for the human body model, a 100 pF capacitor discharged through a 1.5k Ω resistor into each pin.

Note 4: Quiescent current is all current flowing to ground when the voltage at the V_{REG} pin is forced to be above the nominal regulating voltage (V_{REG}).

Note 5: Off current is all of the current flowing to ground including all leakage current that would be drawn from the battery connected to the V_{REG} terminal.

Note 6: When the External pin is being used as the driving source, it is recommended to keep the operating point of $V_{EXT} \leq 1V$. If greater than 1V, the internal circuitry would bias I_{DRIVE} to conduct up to the current limit level continuously causing unnecessary power dissipation in the device.

Typical Performance Characteristics Unless otherwise specified, $T_A = 25^\circ\text{C}$.

LM3620M5-4
Normalized Regulation Voltage
Change vs I_{DRIVE}

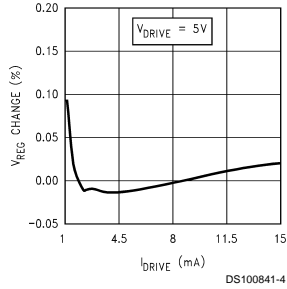

LM3620M5-4
Normalized Regulation Voltage
Change vs V_{DRIVE}

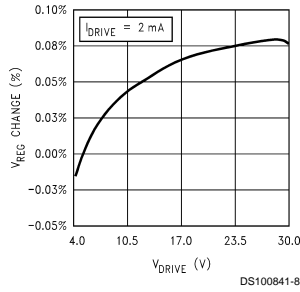

LM3620M5-4
Normalized Regulation Voltage
Change vs I_{EXT}

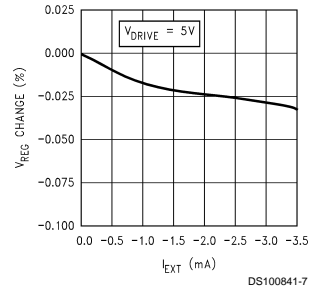

LM3620M5-4
Quiescent Current
vs V_{DRIVE}

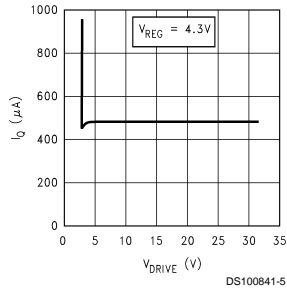

LM3620M5-4
Off State Current vs V_{DRIVE}

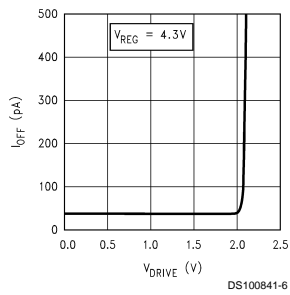

LM3620M5-4
Off State Current
vs Temperature

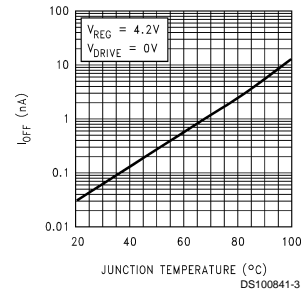

LM3620M5-4
Bode Plot ($\Delta V_{\text{DRIVE}}/\Delta V_{\text{REG}}$)

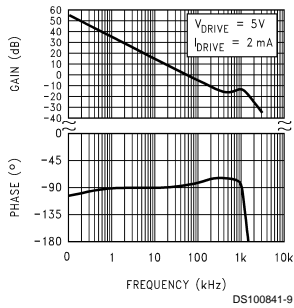

Physical Dimensions inches (millimeters) unless otherwise noted

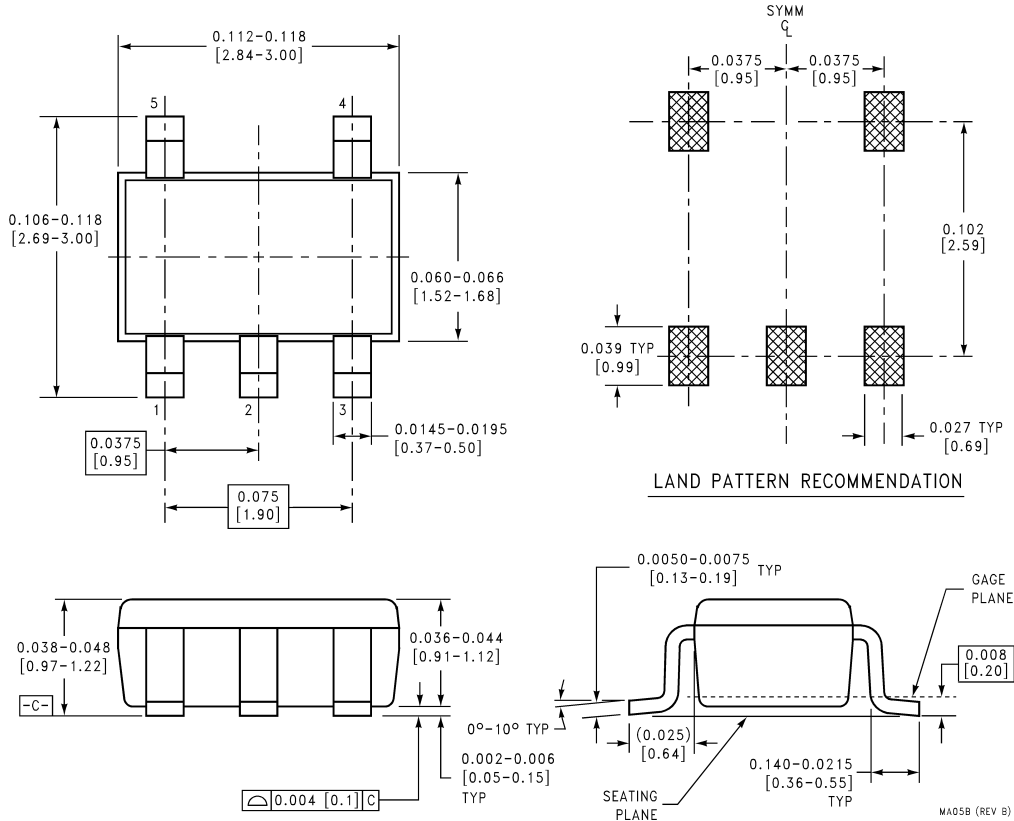

SOT23-5 Package
5-Lead Small-Outline Package (M5)
For Ordering, Refer to Ordering Information Table
NS Package Number MA05B

LIFE SUPPORT POLICY

NATIONAL'S PRODUCTS ARE NOT AUTHORIZED FOR USE AS CRITICAL COMPONENTS IN LIFE SUPPORT DEVICES OR SYSTEMS WITHOUT THE EXPRESS WRITTEN APPROVAL OF THE PRESIDENT AND GENERAL COUNSEL OF NATIONAL SEMICONDUCTOR CORPORATION. As used herein:

1. Life support devices or systems are devices or systems which, (a) are intended for surgical implant into the body, or (b) support or sustain life, and whose failure to perform when properly used in accordance with instructions for use provided in the labeling, can be reasonably expected to result in a significant injury to the user.
2. A critical component is any component of a life support device or system whose failure to perform can be reasonably expected to cause the failure of the life support device or system, or to affect its safety or effectiveness.



National Semiconductor Corporation
 Americas
 Tel: 1-800-272-9959
 Fax: 1-800-737-7018
 Email: support@nsc.com

National Semiconductor Europe
 Fax: +49 (0) 1 80-530 85 86
 Email: europe.support@nsc.com
 Deutsch Tel: +49 (0) 1 80-530 85 85
 English Tel: +49 (0) 1 80-532 78 32
 Français Tel: +49 (0) 1 80-532 93 58
 Italiano Tel: +49 (0) 1 80-534 16 80

National Semiconductor Asia Pacific Customer Response Group
 Tel: 65-2544466
 Fax: 65-2504466
 Email: sea.support@nsc.com

National Semiconductor Japan Ltd.
 Tel: 81-3-5639-7560
 Fax: 81-3-5639-7507

www.national.com