

IDT HIGH-SPEED 3.3V 32K x 9 SYNCHRONOUS PIPELINED DUAL-PORT STATIC RAM

**PRELIMINARY
IDT70V9179L**

Features:

- ◆ True Dual-Ported memory cells which allow simultaneous access of the same memory location
- ◆ High-speed clock to data access
 - Commercial: 7.5/9/12ns (max.)
 - Industrial: 9ns (max)
- ◆ Low-power operation
 - IDT70V9179L
 - Active: 500mW (typ.)
 - Standby: 1.5mW (typ.)
- ◆ Flow-Through or Pipelined output mode on either port via the $\overline{FT}/PIPE$ pins
- ◆ Counter enable and reset features
- ◆ Dual chip enables allow for depth expansion without

- additional logic
- ◆ Full synchronous operation on both ports
 - 4ns setup to clock and 0ns hold on all control, data, and address inputs
 - Data input, address, and control registers
 - Fast 7.5ns clock to data out in the Pipelined output mode
 - Self-timed write allows fast cycle time
 - 12ns cycle time, 83MHz operation in Pipelined output mode
- ◆ LVTTTL-compatible, single 3.3V ($\pm 0.3V$) power supply
- ◆ Industrial temperature range ($-40^{\circ}C$ to $+85^{\circ}C$) is available for selected speeds
- ◆ Available in a 100-pin Thin Quad Flatpack (TQFP)

Functional Block Diagram

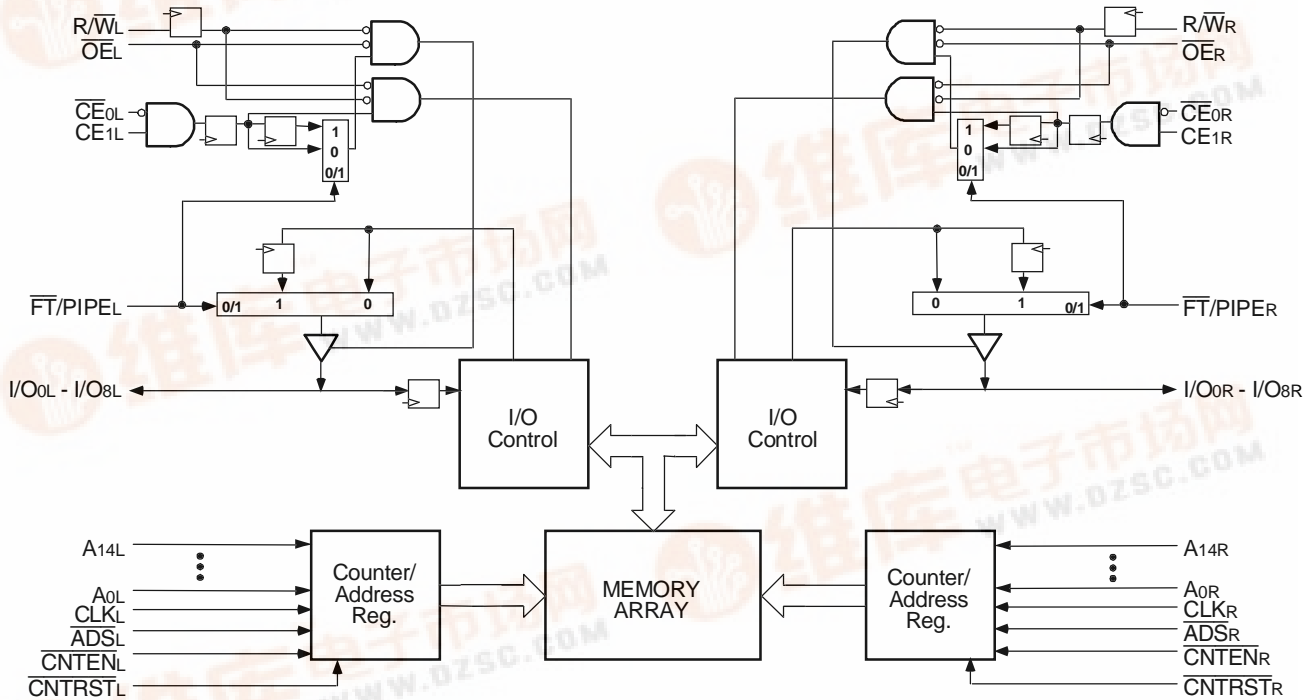

5645 drw 01



Description:

The IDT70V9179 is a high-speed 32K x 9 bit synchronous Dual-Port RAM. The memory array utilizes Dual-Port memory cells to allow simultaneous access of any address from both ports. Registers on control, data, and address inputs provide minimal setup and hold times. The timing latitude provided by this approach allows systems to be designed with very short cycle times.

With an input data register, the IDT70V9179 has been optimized for applications having unidirectional or bidirectional data flow in bursts. An automatic power down feature, controlled by $\overline{CE0}$ and $CE1$, permits the on-chip circuitry of each port to enter a very low standby power mode. Fabricated using IDT's CMOS high-performance technology, these devices typically operate on only 500mW of power.

Pin Configuration^(1,2,3)

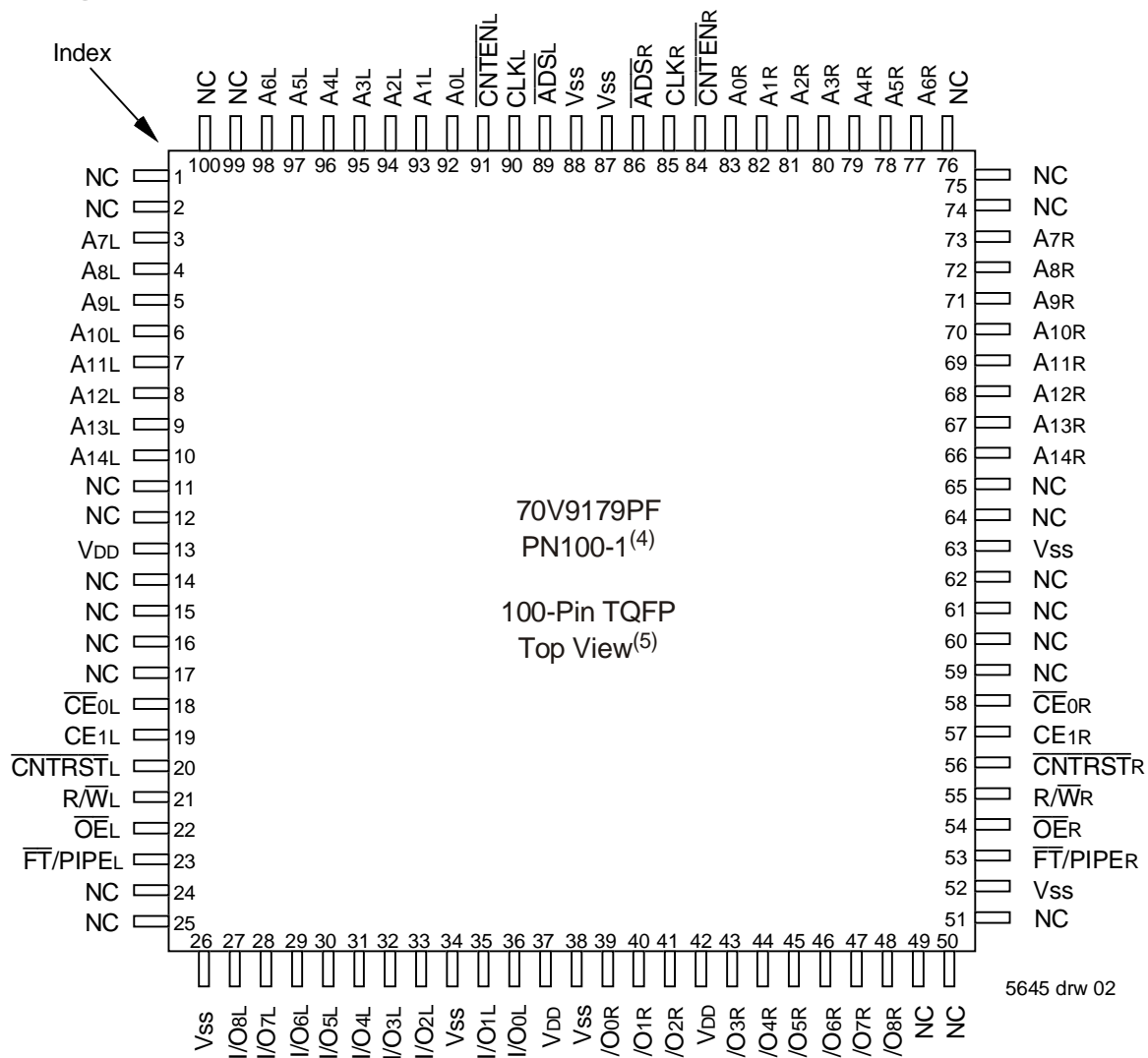

NOTES:

1. All V_{DD} pins must be connected to power supply.
2. All V_{SS} pins must be connected to ground.
3. Package body is approximately 14mm x 14mm x 1.4mm.
4. This package code is used to reference the package diagram.
5. This text does not indicate orientation of the actual part-marking.

Pin Names

Left Port	Right Port	Names
\overline{CE}_{0L} , CE1L	\overline{CE}_{0R} , CE1R	Chip Enables
R/ \overline{W} L	R/ \overline{W} R	Read/Write Enable
\overline{OE} L	\overline{OE} R	Output Enable
A0L - A14L	A0R - A14R	Address
I/O0L - I/O8L	I/O0R - I/O8R	Data Input/Output
CLKL	CLKR	Clock
\overline{ADS} L	\overline{ADS} R	Address Strobe Enable
\overline{CNTEN} L	\overline{CNTEN} R	Counter Enable
\overline{CNTRST} L	\overline{CNTRST} R	Counter Reset
$\overline{FT/PIPE}$ L	$\overline{FT/PIPE}$ R	Flow-Through / Pipeline
V _{DD}		Power (3.3V)
V _{SS}		Ground (0V)

5645 tbl 01

Truth Table I—Read/Write and Enable Control^(1,2,3)

\overline{OE}	CLK	\overline{CE}_0	CE1	R/ \overline{W}	I/O ₀₋₈	MODE
X	↑	H	X	X	High-Z	Deselected—Power Down
X	↑	X	L	X	High-Z	Deselected—Power Down
X	↑	L	H	L	DATA _N	Write
L	↑	L	H	H	DATA _{OUT}	Read
H	X	L	H	X	High-Z	Outputs Disabled

5645 tbl 02

NOTES:

- "H" = V_{IH}, "L" = V_{IL}, "X" = Don't Care.
- \overline{ADS} , \overline{CNTEN} , \overline{CNTRST} = X.
- \overline{OE} is an asynchronous input signal.

Truth Table II—Address Counter Control^(1,2,6)

Address	Previous Address	Addr Used	CLK ⁽⁶⁾	\overline{ADS}	\overline{CNTEN}	\overline{CNTRST}	I/O ⁽³⁾	MODE
A _n	X	A _n	↑	L ⁽⁴⁾	X	H	D _{I/O} (n)	External Address Used
X	A _n	A _n + 1	↑	H	L ⁽⁵⁾	H	D _{I/O} (n+1)	Counter Enabled—Internal Address generation
X	A _n + 1	A _n + 1	↑	H	H	H	D _{I/O} (n+1)	External Address Blocked—Counter disabled (A _n + 1 reused)
X	X	A ₀	↑	X	X	L ⁽⁴⁾	D _{I/O} (0)	Counter Reset to Address 0

5645 tbl 03

NOTES:

- "H" = V_{IH}, "L" = V_{IL}, "X" = Don't Care.
- \overline{CE}_0 and \overline{OE} = V_{IL}; CE1 and R/ \overline{W} = V_{IH}.
- Outputs configured in Flow-Through Output mode; if outputs are in Pipelined mode the data out will be delayed by one cycle.
- \overline{ADS} and \overline{CNTRST} are independent of all other signals including \overline{CE}_0 and CE1.
- The address counter advances if \overline{CNTEN} = V_{IL} on the rising edge of CLK, regardless of all other signals including \overline{CE}_0 and CE1.
- While an external address is being loaded (\overline{ADS} = V_{IL}), R/ \overline{W} = V_{IH} is recommended to ensure data is not written arbitrarily.

Recommended Operating Temperature and Supply Voltage

Grade	Ambient Temperature ⁽¹⁾	GND	V _{DD}
Commercial	0°C to +70°C	0V	3.3V ± 0.3V
Industrial	-40°C to +85°C	0V	3.3V ± 0.3V

5645 tbl 04

NOTES:

- This is the parameter T_A. This is the "instant on" case temperature.

Recommended DC Operating Conditions

Symbol	Parameter	Min.	Typ.	Max.	Unit
V _{DD}	Supply Voltage	3.0	3.3	3.6	V
V _{SS}	Ground	0	0	0	V
V _{IH}	Input High Voltage	2.0V	—	V _{DD} +0.3V ⁽²⁾	V
V _{IL}	Input Low Voltage	-0.3 ⁽¹⁾	—	0.8	V

5645 tbl 05

NOTES:

- V_{IL} ≥ -1.5V for pulse width less than 10 ns.
- V_{TERM} must not exceed V_{DD} + 0.3V.

Absolute Maximum Ratings⁽¹⁾

Symbol	Rating	Commercial & Industrial	Unit
V _{TERM} ⁽²⁾	Terminal Voltage with Respect to GND	-0.5 to +4.6	V
T _{BIAS}	Temperature Under Bias	-55 to +125	°C
T _{STG}	Storage Temperature	-65 to +150	°C
I _{OUT}	DC Output Current	50	mA

5645 tbl 06

NOTES:

- Stresses greater than those listed under ABSOLUTE MAXIMUM RATINGS may cause permanent damage to the device. This is a stress rating only and functional operation of the device at these or any other conditions above those indicated in the operational sections of this specification is not implied. Exposure to absolute maximum rating conditions for extended periods may affect reliability.
- V_{TERM} must not exceed V_{DD} + 0.3V for more than 25% of the cycle time or 10ns maximum, and is limited to ≤ 20mA for the period of V_{TERM} ≥ V_{DD} + 0.3V.

Capacitance⁽¹⁾

(T_A = +25°C, f = 1.0MHz)

Symbol	Parameter	Conditions ⁽²⁾	Max.	Unit
C _{IN}	Input Capacitance	V _{IN} = 3dV	9	pF
C _{OUT} ⁽³⁾	Output Capacitance	V _{OUT} = 3dV	10	pF

5645 tbl 07

NOTES:

- These parameters are determined by device characterization, but are not production tested.
- 3dV references the interpolated capacitance when the input and output switch from 0V to 3V or from 3V to 0V.
- C_{OUT} also references C_{IO}.

DC Electrical Characteristics Over the Operating Temperature and Supply Voltage Range (V_{DD} = 3.3V ± 0.3V)

Symbol	Parameter	Test Conditions	70V9179L		Unit
			Min.	Max.	
I _{LI}	Input Leakage Current ⁽¹⁾	V _{DD} = 3.6V, V _{IN} = 0V to V _{DD}	—	5	μA
I _{LO}	Output Leakage Current	$\overline{CE} = V_{IH}$ or CE1 = V _{IL} , V _{OUT} = 0V to V _{DD}	—	5	μA
V _{OL}	Output Low Voltage	I _{OL} = +4mA	—	0.4	V
V _{OH}	Output High Voltage	I _{OH} = -4mA	2.4	—	V

5645 tbl 08

NOTE:

- At V_{DD} ≤ 2.0V input leakages are undefined.

DC Electrical Characteristics Over the Operating Temperature Supply Voltage Range⁽³⁾ ($V_{DD} = 3.3V \pm 0.3V$)

Symbol	Parameter	Test Condition	Version	70V9179L7 Com'l Only		70V9179L9 Com'l & Ind		70V9179L12 Com'l Only		Unit	
				Typ. ⁽⁴⁾	Max.	Typ. ⁽⁴⁾	Max.	Typ. ⁽⁴⁾	Max.		
I _{DD}	Dynamic Operating Current (Both Ports Active)	\overline{CE}_L and $\overline{CE}_R = V_{IL}$, Outputs Disabled, $f = f_{MAX}^{(1)}$	COM'L	L	200	310	180	260	150	230	mA
			IND	L	—	—	180	280	—	—	
ISB1	Standby Current (Both Ports - TTL Level Inputs)	$\overline{CE}_L = \overline{CE}_R = V_{IH}$ $f = f_{MAX}^{(1)}$	COM'L	L	65	130	50	100	40	80	mA
			IND	L	—	—	50	120	—	—	
ISB2	Standby Current (One Port - TTL Level Inputs)	$\overline{CE}^*A = V_{IL}$ and $\overline{CE}^*B = V_{IH}^{(5)}$ Active Port Outputs Disabled, $f = f_{MAX}^{(1)}$	COM'L	L	140	245	110	190	100	175	mA
			IND	L	—	—	110	205	—	—	
ISB3	Full Standby Current (Both Ports - CMOS Level Inputs)	Both Ports \overline{CE}_L and $\overline{CE}_R \geq V_{DD} - 0.2V$, $V_{IN} \geq V_{DD} - 0.2V$ or $V_{IN} \leq 0.2V$, $f = 0^{(2)}$	COM'L	L	0.4	3	0.4	3.0	0.4	3	mA
			IND	L	—	—	0.4	6.0	—	—	
ISB4	Full Standby Current (One Port - CMOS Level Inputs)	$\overline{CE}^*A \leq 0.2V$ and $\overline{CE}^*B \geq V_{DD} - 0.2V^{(5)}$ $V_{IN} \geq V_{DD} - 0.2V$ or $V_{IN} \leq 0.2V$, Active Port, Outputs Disabled, $f = f_{MAX}^{(1)}$	COM'L	L	130	235	100	180	90	165	mA
			IND	L	—	—	100	195	—	—	

5645 tbl 09

NOTES:

- At $f = f_{MAX}$, address and control lines (except Output Enable) are cycling at the maximum frequency clock cycle of $1/t_{cyc}$, using "AC TEST CONDITIONS" at input levels of GND to 3V.
- $f = 0$ means no address, clock, or control lines change. Applies only to input at CMOS level standby.
- Port "A" may be either left or right port. Port "B" is the opposite from port "A".
- $V_{DD} = 3.3V$, $T_A = 25^\circ C$ for Typ, and are not production tested. $I_{DD} DC(f=0) = 90mA$ (Typ).
- $\overline{CE}_X = V_{IL}$ means $\overline{CE}_{0X} = V_{IL}$ and $CE_{1X} = V_{IH}$
 $\overline{CE}_X = V_{IH}$ means $\overline{CE}_{0X} = V_{IH}$ or $CE_{1X} = V_{IL}$
 $\overline{CE}_X \leq 0.2V$ means $\overline{CE}_{0X} \leq 0.2V$ and $CE_{1X} \geq V_{DD} - 0.2V$
 $\overline{CE}_X \geq V_{DD} - 0.2V$ means $\overline{CE}_{0X} \geq V_{DD} - 0.2V$ or $CE_{1X} \leq 0.2V$
"X" represents "L" for left port or "R" for right port.

AC Test Conditions

Input Pulse Levels	GND to 3.0V
Input Rise/Fall Times	3ns Max.
Input Timing Reference Levels	1.5V
Output Reference Levels	1.5V
Output Load	Figures 1, 2, and 3

5645 tbl 10

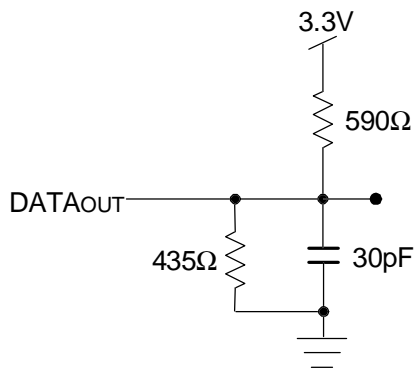

5645 drw 03

Figure 1. AC Output Test load.

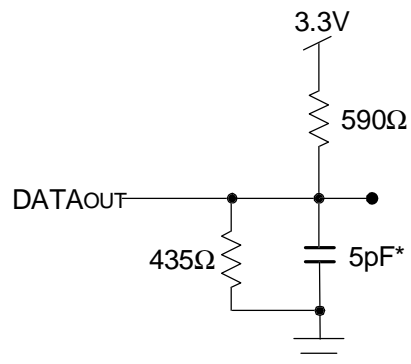

5645 drw 04

Figure 2. Output Test Load
(For tCKLZ, tCKHZ, tOLZ, and tOHZ).
*Including scope and jig.

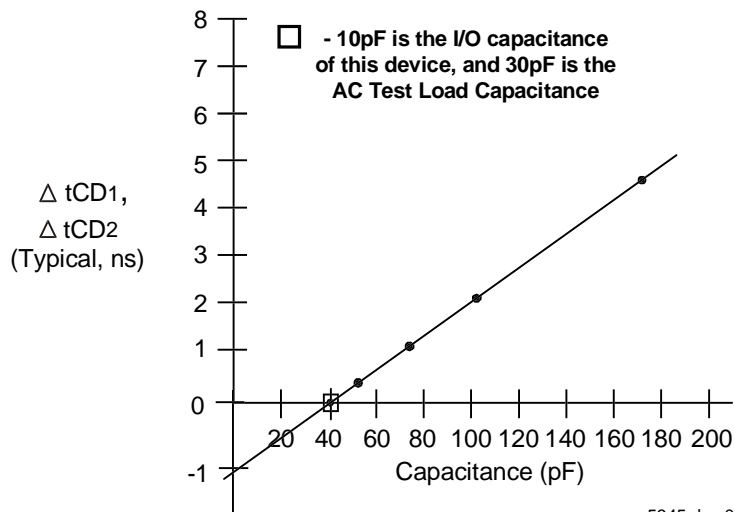

5645 drw 05

Figure 3. Typical Output Derating (Lumped Capacitive Load).

AC Electrical Characteristics Over the Operating Temperature Range (Read and Write Cycle Timing)⁽³⁾ ($V_{DD} = 3.3V \pm 0.3V$, $T_A = 0^\circ C$ to $+70^\circ C$)

Symbol	Parameter	70V9179L7 Com'1 Only		70V9179L9 Com'1 & Ind		70V9179L12 Com'1 Only		Unit
		Min.	Max.	Min.	Max.	Min.	Max.	
t _{CYC1}	Clock Cycle Time (Flow-Through) ⁽²⁾	22	—	25	—	30	—	ns
t _{CYC2}	Clock Cycle Time (Pipelined) ⁽²⁾	12	—	15	—	20	—	ns
t _{CH1}	Clock High Time (Flow-Through) ⁽²⁾	7.5	—	12	—	12	—	ns
t _{CL1}	Clock Low Time (Flow-Through) ⁽²⁾	7.5	—	12	—	12	—	ns
t _{CH2}	Clock High Time (Pipelined) ⁽²⁾	5	—	6	—	8	—	ns
t _{CL2}	Clock Low Time (Pipelined) ⁽²⁾	5	—	6	—	8	—	ns
t _r	Clock Rise Time	—	3	—	3	—	3	ns
t _f	Clock Fall Time	—	3	—	3	—	3	ns
t _{SA}	Address Setup Time	4	—	4	—	4	—	ns
t _{HA}	Address Hold Time	0	—	1	—	1	—	ns
t _{SC}	Chip Enable Setup Time	4	—	4	—	4	—	ns
t _{HC}	Chip Enable Hold Time	0	—	1	—	1	—	ns
t _{SW}	R/W Setup Time	4	—	4	—	4	—	ns
t _{HW}	R/W Hold Time	0	—	1	—	1	—	ns
t _{SD}	Input Data Setup Time	4	—	4	—	4	—	ns
t _{HD}	Input Data Hold Time	0	—	1	—	1	—	ns
t _{SAD}	\overline{ADS} Setup Time	4	—	4	—	4	—	ns
t _{HAD}	\overline{ADS} Hold Time	0	—	1	—	1	—	ns
t _{SCN}	\overline{CNTEN} Setup Time	4	—	4	—	4	—	ns
t _{HCN}	\overline{CNTEN} Hold Time	0	—	1	—	1	—	ns
t _{SRST}	\overline{CNTRST} Setup Time	4	—	4	—	4	—	ns
t _{HRST}	\overline{CNTRST} Hold Time	0	—	1	—	1	—	ns
t _{OE}	Output Enable to Data Valid	—	9	—	12	—	12	ns
t _{OLZ}	Output Enable to Output Low-Z ⁽¹⁾	2	—	2	—	2	—	ns
t _{OHZ}	Output Enable to Output High-Z ⁽¹⁾	1	7	1	7	1	7	ns
t _{CD1}	Clock to Data Valid (Flow-Through) ⁽²⁾	—	18	—	20	—	25	ns
t _{CD2}	Clock to Data Valid (Pipelined) ⁽²⁾	—	7.5	—	9	—	12	ns
t _{DC}	Data Output Hold After Clock High	2	—	2	—	2	—	ns
t _{CKHZ}	Clock High to Output High-Z ⁽¹⁾	2	9	2	9	2	9	ns
t _{CKLZ}	Clock High to Output Low-Z ⁽¹⁾	2	—	2	—	2	—	ns
Port-to-Port Delay								
t _{OWDD}	Write Port Clock High to Read Data Delay	—	28	—	35	—	40	ns
t _{OCS}	Clock-to-Clock Setup Time	—	10	—	15	—	15	ns

5645 tbl 11

NOTES:

1. Transition is measured 0mV from Low or High-impedance voltage with the Output Test Load (Figure 2). This parameter is guaranteed by device characterization, but is not production tested.
2. The Pipelined output parameters (t_{CYC2}, t_{CD2}) apply to either or both the Left and Right ports when $\overline{FT}/PIPE = V_{IH}$. Flow-through parameters (t_{CYC1}, t_{CD1}) apply when $\overline{FT}/PIPE = V_{IL}$ for that port.
3. All input signals are synchronous with respect to the clock except for the asynchronous Output Enable (\overline{OE}), $\overline{FT}/PIPE_R$, and $\overline{FT}/PIPE_L$.

Timing Waveform of Read Cycle for Flow-Through Output ($\overline{FT}/PIPE^{\text{X}} = V_{IL}$)^(3,6)

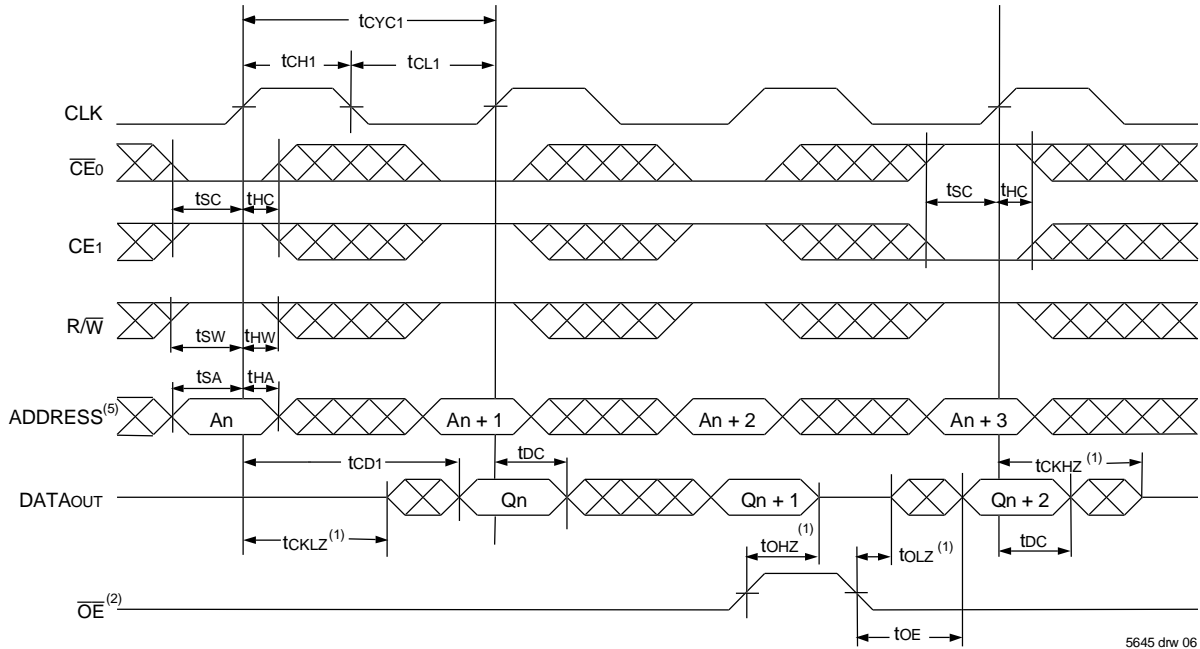

5645 drw 06

Timing Waveform of Read Cycle for Pipelined Operation ($\overline{FT}/PIPE^{\text{X}} = V_{IH}$)^(3,6)

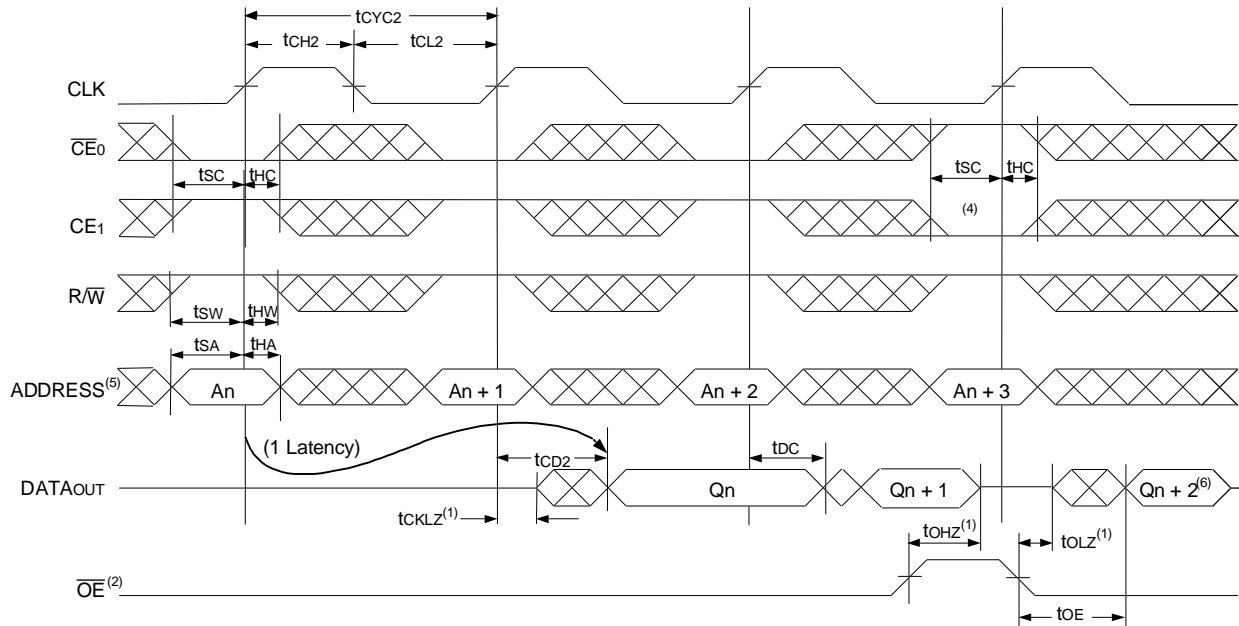

5645 drw 07

NOTES:

1. Transition is measured 0mV from Low or High-impedance voltage with the Output Test Load (Figure 2).
2. \overline{OE} is asynchronously controlled; all other inputs are synchronous to the rising clock edge.
3. $\overline{ADS} = V_{IL}$, \overline{CNTEN} and $\overline{CNTRST} = V_{IH}$.
4. The output is disabled (High-Impedance state) by $\overline{CE0} = V_{IH}$ or $CE1 = V_{IL}$ following the next rising edge of the clock. Refer to Truth Table 1.
5. Addresses do not have to be accessed sequentially since $\overline{ADS} = V_{IL}$ constantly loads the address on the rising edge of the CLK; numbers are for reference use only.
6. "X" here denotes Left or Right port. The diagram is with respect to that port.

Timing Waveform of a Bank Select Pipelined Read^(1,2)

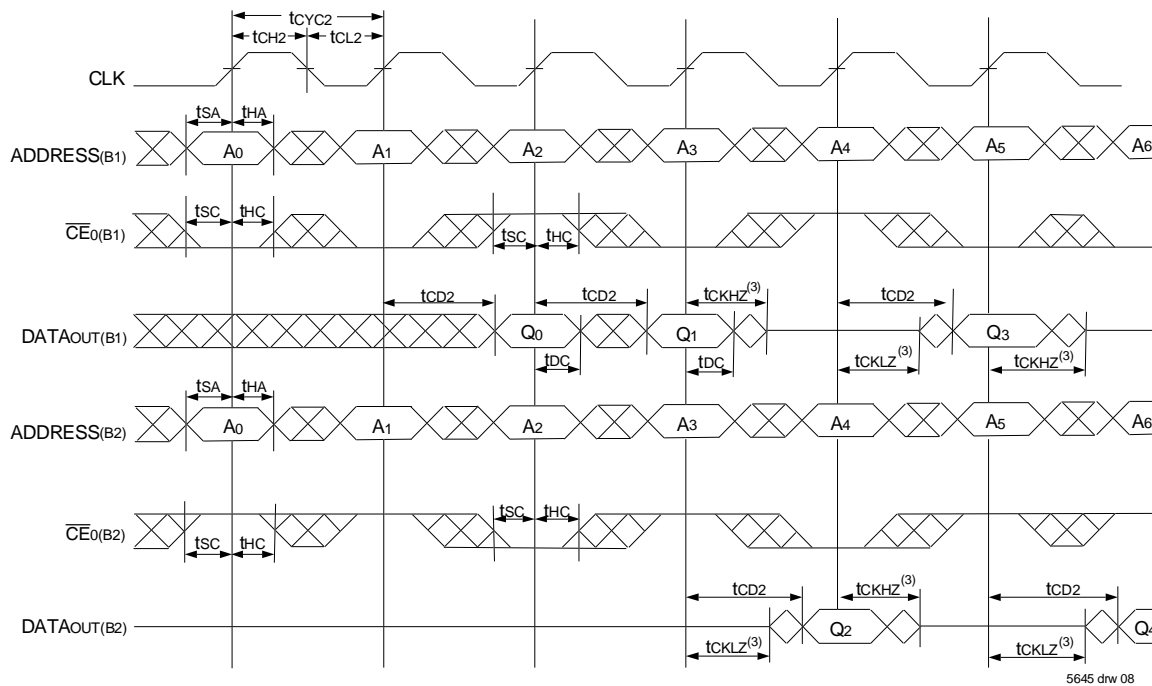

Timing Waveform with Port-to-Port Flow-Through Read^(4,5,7)

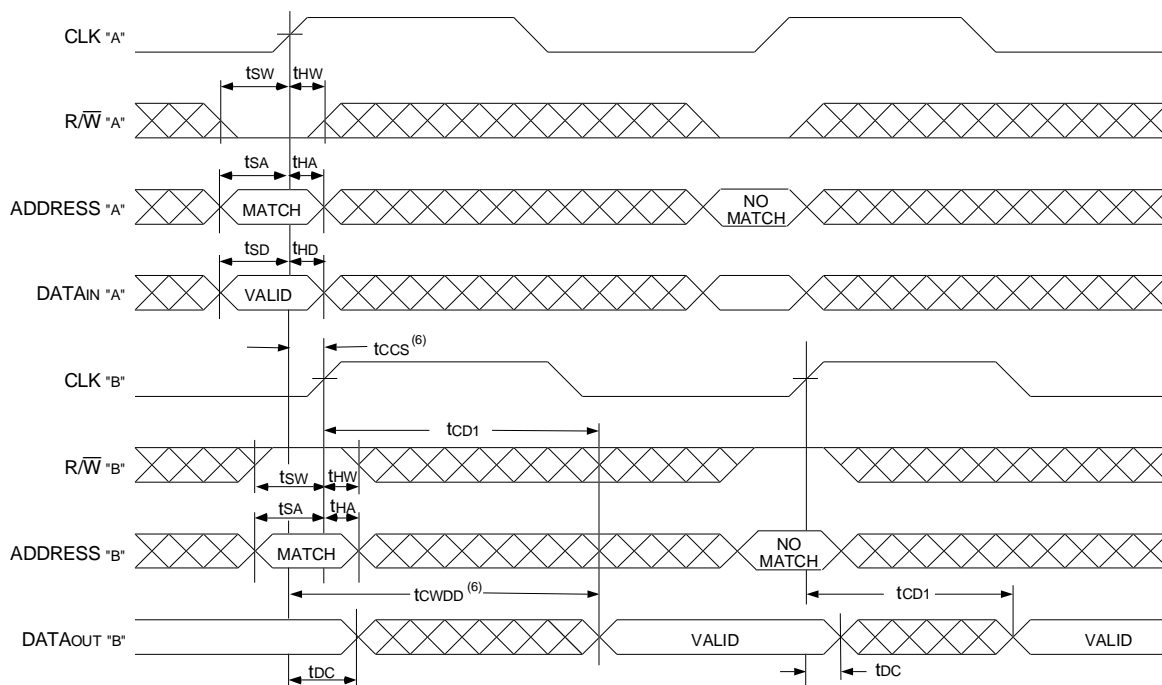

NOTES:

1. B1 Represents Bank #1; B2 Represents Bank #2. Each Bank consists of one IDT70V9179 for this waveform, and are setup for depth expansion in this example. ADDRESS(B1) = ADDRESS(B2) in this situation.
2. \overline{OE} , and $\overline{ADS} = V_{IL}$; $CE_1(B1)$, $CE_1(B2)$, R/\overline{W} , \overline{CNTEN} , and $\overline{CNTRST} = V_{IH}$.
3. Transition is measured 0mV from Low or High-impedance voltage with the Output Test Load (Figure 2).
4. \overline{CE}_0 and $\overline{ADS} = V_{IL}$; CE_1 , \overline{CNTEN} , and $\overline{CNTRST} = V_{IH}$.
5. $\overline{OE} = V_{IL}$ for the Right Port, which is being read from. $\overline{OE} = V_{IH}$ for the Left Port, which is being written to.
6. If $t_{CCS} \leq$ maximum specified, then data from right port READ is not valid until the maximum specified for t_{CWD} . If $t_{CCS} >$ maximum specified, then data from right port READ is not valid until $t_{CCS} + t_{CD1}$. t_{CWD} does not apply in this case.
7. All timing is the same for both Left and Right ports. Port "A" may be either Left or Right port. Port "B" is the opposite from Port "A".

Timing Waveform of Pipelined Read-to-Write-to-Read ($\overline{OE} = V_{IL}$)⁽³⁾

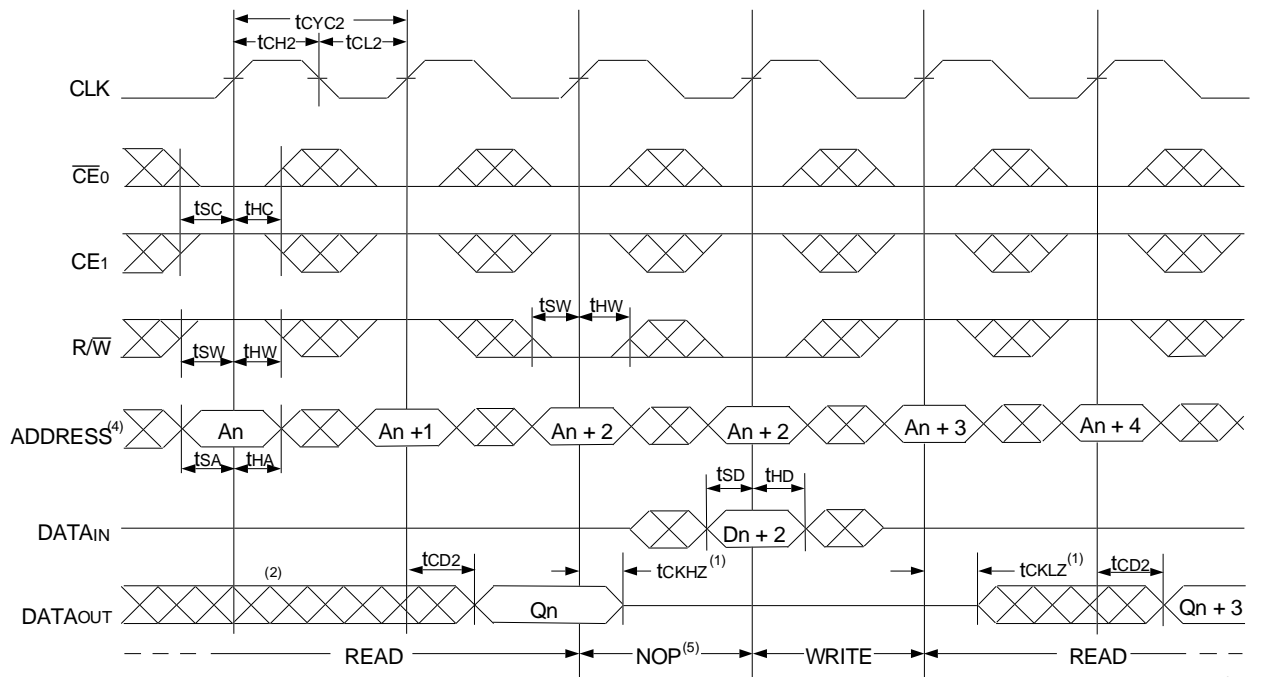

5645 drw 10

Timing Waveform of Pipelined Read-to-Write-to-Read (\overline{OE} Controlled)⁽³⁾

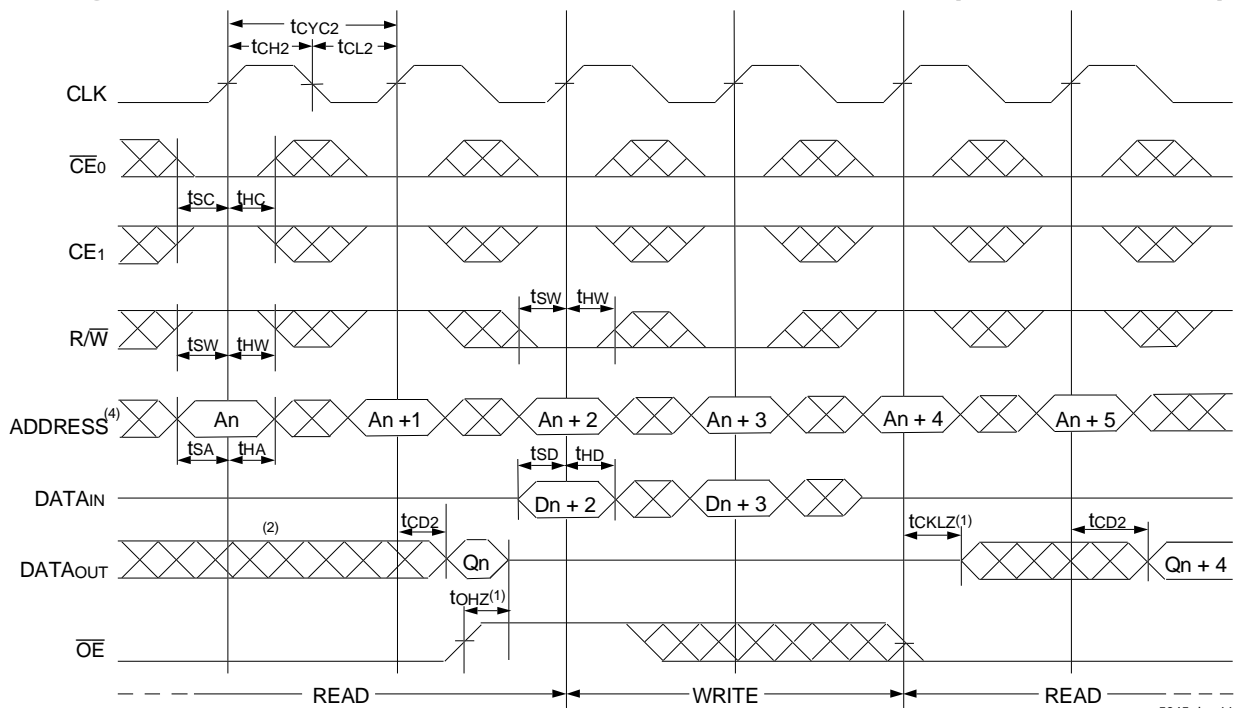

5645 drw 11

NOTES:

1. Transition is measured 0mV from Low or High-impedance voltage with the Output Test Load (Figure 2).
2. Output state (High, Low, or High-impedance) is determined by the previous cycle control signals.
3. $\overline{CE0}$ and $\overline{ADS} = V_{IL}$; $\overline{CE1}$, \overline{CNTEN} , and $\overline{CNTRST} = V_{IH}$. "NOP" is "No Operation".
4. Addresses do not have to be accessed sequentially since $\overline{ADS} = V_{IL}$ constantly loads the address on the rising edge of the CLK; numbers are for reference use only.
5. "NOP" is "No Operation." Data in memory at the selected address may be corrupted and should be re-written to guarantee data integrity.

Timing Waveform of Flow-Through Read-to-Write-to-Read ($\overline{OE} = V_{IL}$)⁽³⁾

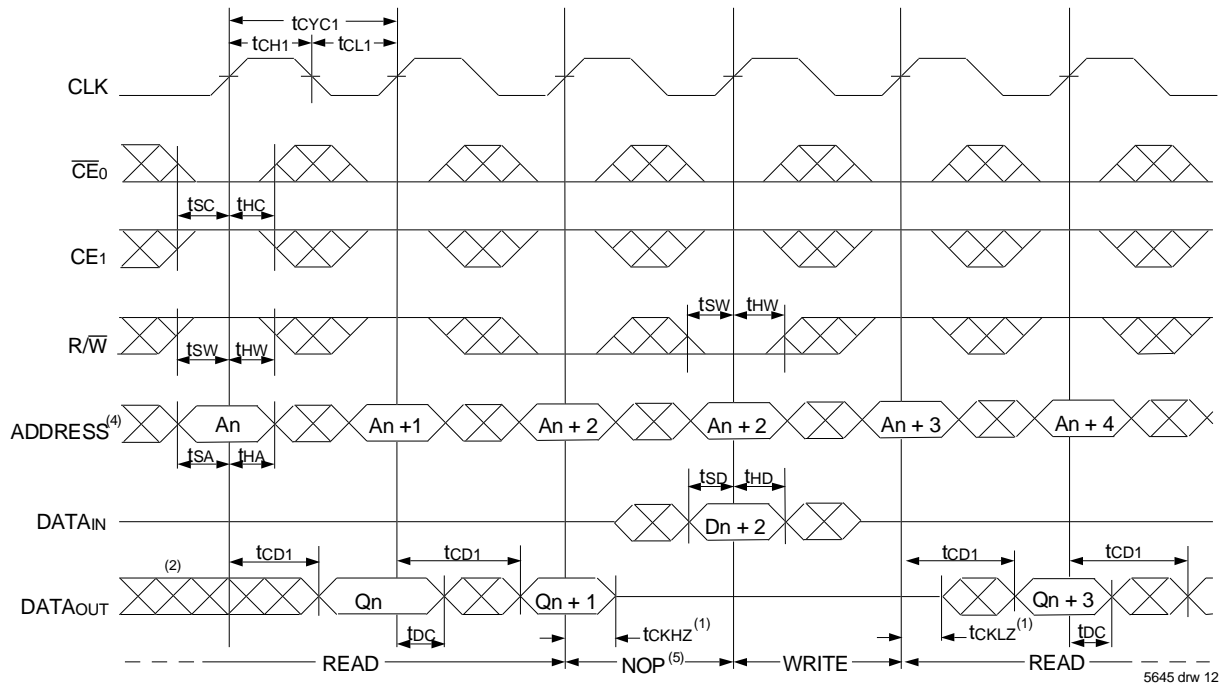

Timing Waveform of Flow-Through Read-to-Write-to-Read (\overline{OE} Controlled)⁽³⁾

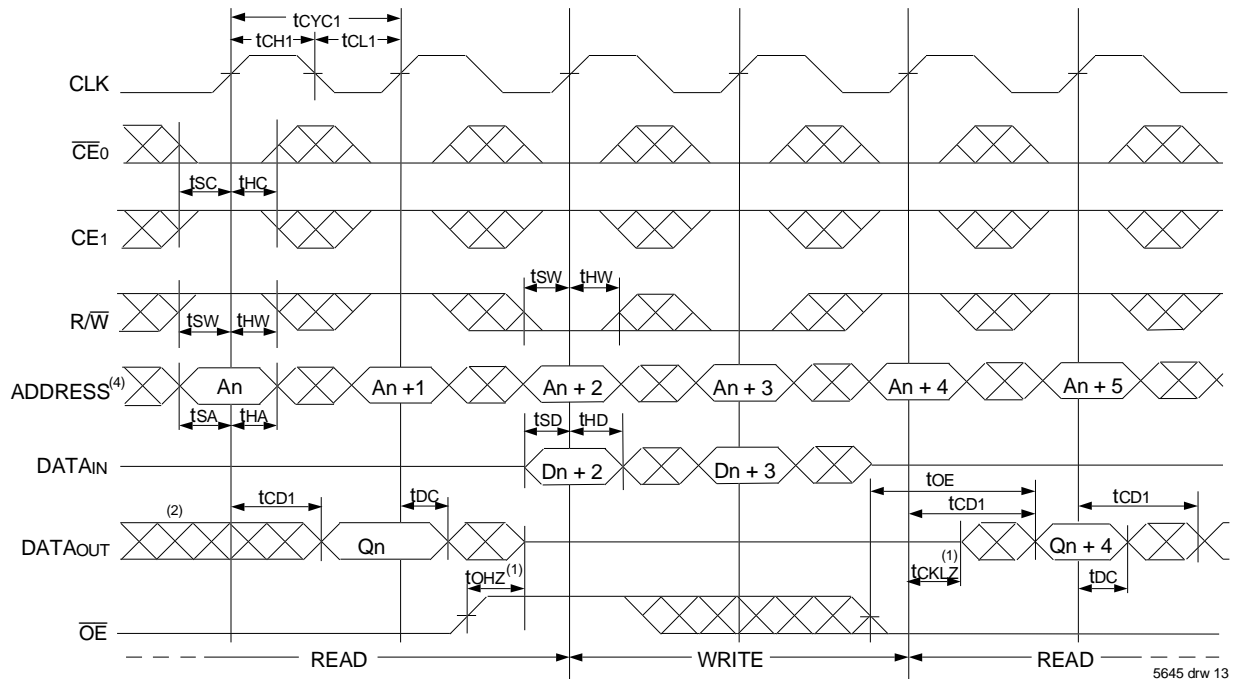

NOTES:

1. Transition is measured 0mV from Low or High-impedance voltage with the Output Test Load (Figure 2).
2. Output state (High, Low, or High-impedance) is determined by the previous cycle control signals.
3. $\overline{CE0}$ and $\overline{ADS} = V_{IL}$; $\overline{CE1}$, \overline{CNTEN} , and $\overline{CNTRST} = V_{IH}$. "NOP" is "No Operation".
4. Addresses do not have to be accessed sequentially since $\overline{ADS} = V_{IL}$ constantly loads the address on the rising edge of the CLK; numbers are for reference use only.
5. "NOP" is "No Operation." Data in memory at the selected address may be corrupted and should be re-written to guarantee data integrity.

Timing Waveform of Pipelined Read with Address Counter Advance⁽¹⁾

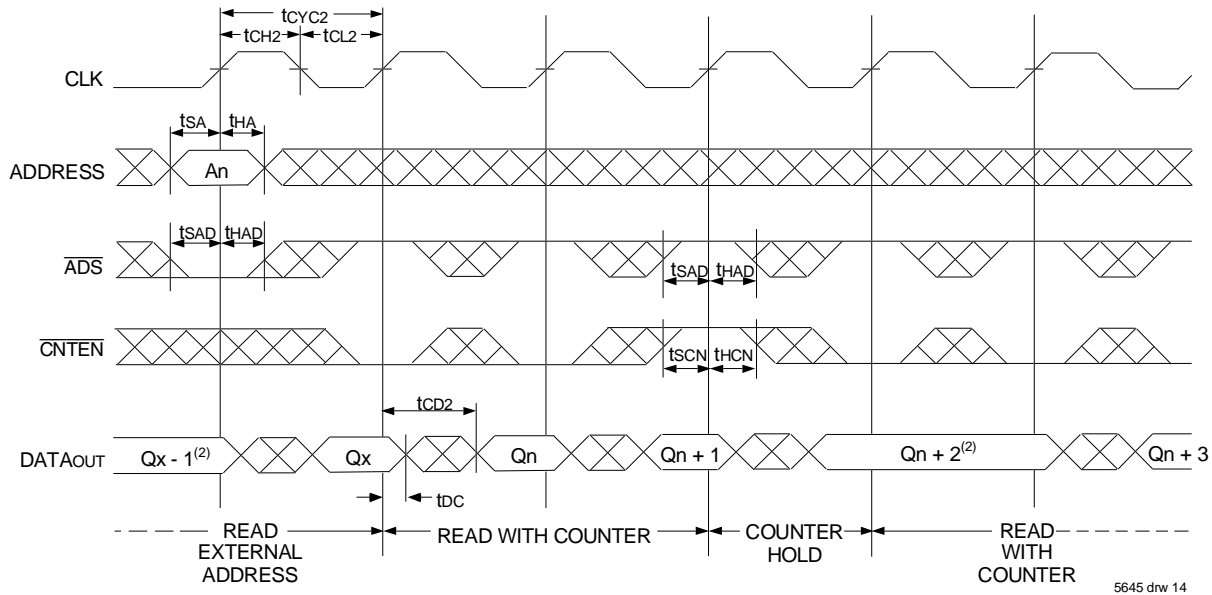

Timing Waveform of Flow-Through Read with Address Counter Advance⁽¹⁾

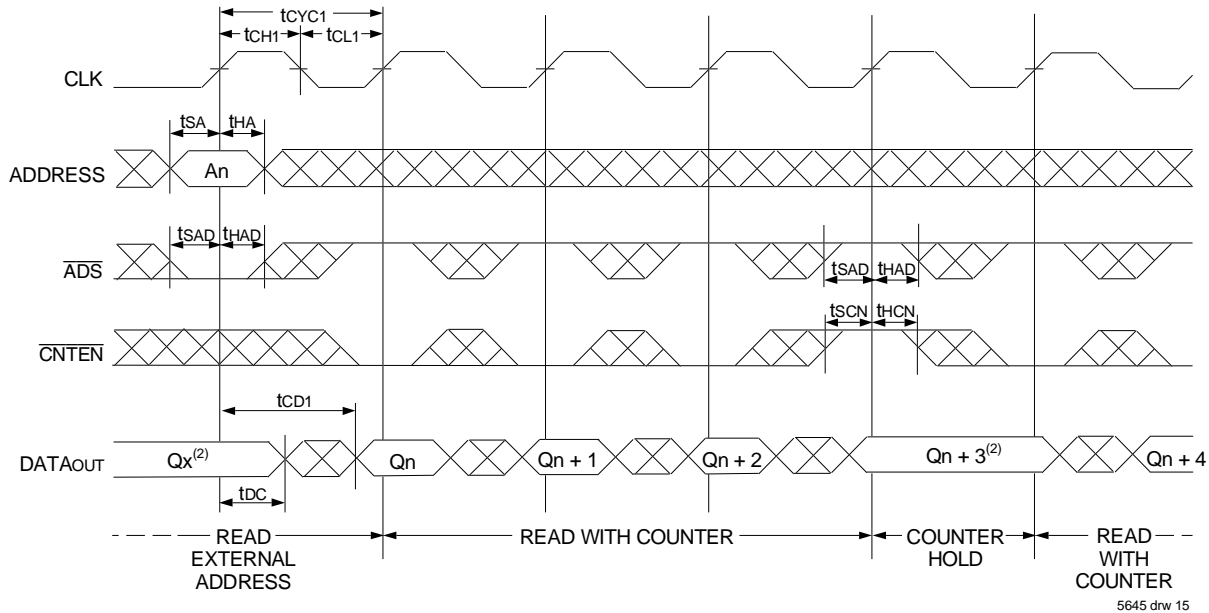

NOTES:

1. \overline{CE}_0 and $\overline{OE} = V_{IL}$; CE_1 , R/\overline{W} , and $\overline{CNRST} = V_{IH}$.
2. If there is no address change via $\overline{ADS} = V_{IL}$ (loading a new address) or $\overline{CNTEN} = V_{IL}$ (advancing the address), i.e. $\overline{ADS} = V_{IH}$ and $\overline{CNTEN} = V_{IH}$, then the data output remains constant for subsequent clocks.

Timing Waveform of Write with Address Counter Advance (Flow-Through or Pipelined Outputs)⁽¹⁾

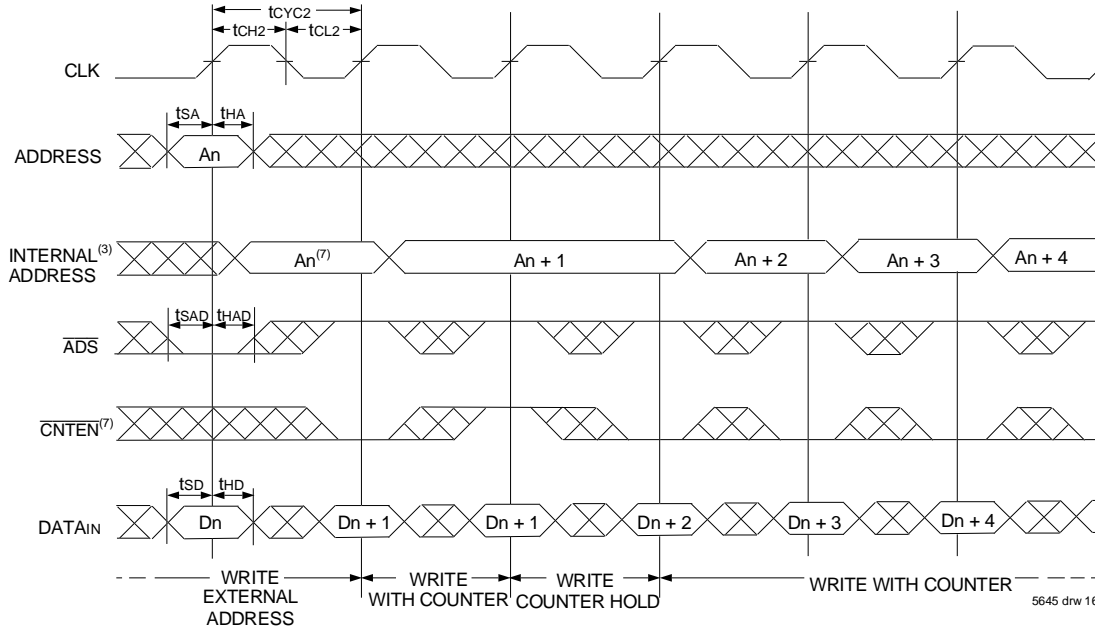

5645 drw 16

Timing Waveform of Counter Reset (Pipelined Outputs)⁽²⁾

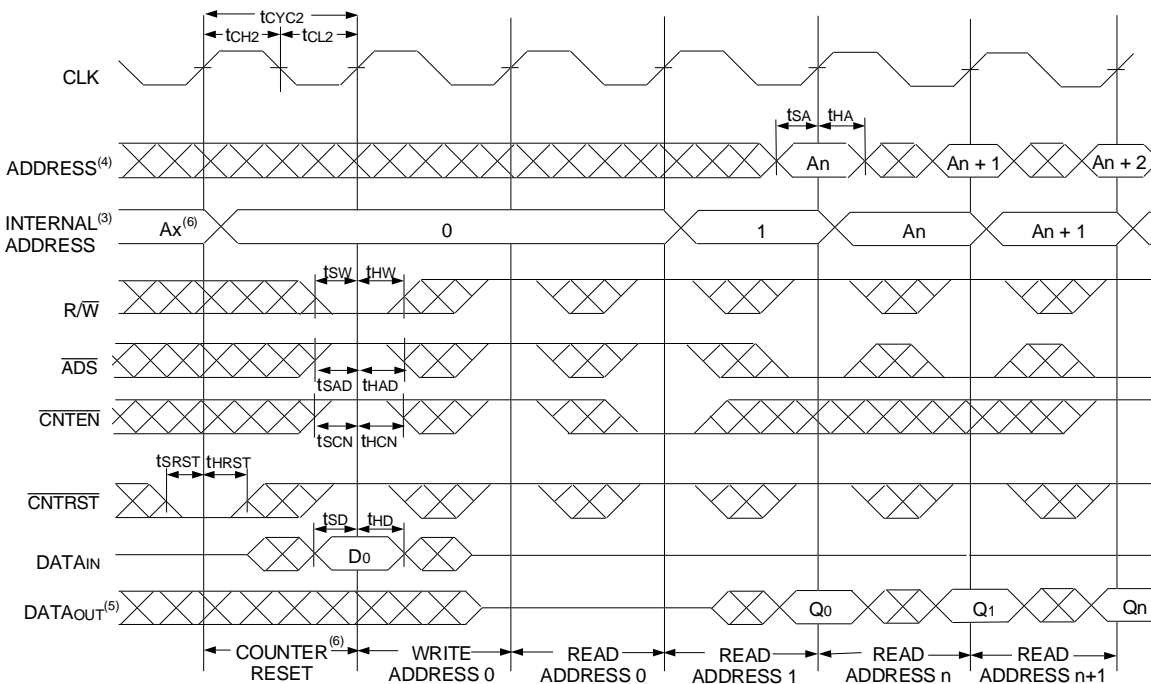

5645 drw 17

NOTES:

- \overline{CE}_0 and $\overline{R/W} = V_{IL}$; CE_1 and $\overline{CNTRST} = V_{IH}$.
- $\overline{CE}_0 = V_{IL}$; $CE_1 = V_{IH}$.
- The "Internal Address" is equal to the "External Address" when $\overline{ADS} = V_{IL}$ and equals the counter output when $\overline{ADS} = V_{IH}$.
- Addresses do not have to be accessed sequentially since $\overline{ADS} = V_{IL}$ constantly loads the address on the rising edge of the CLK; numbers are for reference use only.
- Output state (High, Low, or High-impedance) is determined by the previous cycle control signals.
- No dead cycle exists during counter reset. A READ or WRITE cycle may be coincidental with the counter reset cycle. ADDR₀ will be accessed. Extra cycles are shown here simply for clarification.
- $\overline{CNTEN} = V_{IL}$ advances Internal Address from 'An' to 'An + 1'. The transition shown indicates the time required for the counter to advance. The 'An + 1' Address is written to during this cycle.

Functional Description

The IDT70V9179 provides a true synchronous Dual-Port Static RAM interface. Registered inputs provide minimal set-up and hold times on address, data, and all critical control inputs. All internal registers are clocked on the rising edge of the clock signal, however, the self-timed internal write pulse is independent of the LOW to HIGH transition of the clock signal.

An asynchronous output enable is provided to ease asynchronous bus interfacing. Counter enable inputs are also provided to staff the operation of the address counters for fast interleaved memory applications.

$\overline{CE_0} = V_{IH}$ or $CE_1 = V_{IL}$ for one clock cycle will power down the internal circuitry to reduce static power consumption. Multiple chip enables allow easier banking of multiple IDT70V9179's for depth expansion configurations. When the Pipelined output mode is enabled, two cycles are required with $\overline{CE_0} = V_{IL}$ and $CE_1 = V_{IH}$ to re-activate the outputs.

Depth and Width Expansion

The IDT70V9179 features dual chip enables (refer to Truth Table I) in order to facilitate rapid and simple depth expansion with no requirements for external logic. Figure 4 illustrates how to control the various chip enables in order to expand two devices in depth.

The IDT70V9179 can also be used in applications requiring expanded width, as indicated in Figure 4. Since the banks are allocated at the discretion of the user, the external controller can be set up to drive the input signals for the various devices as required to allow for 18-bit or wider applications.

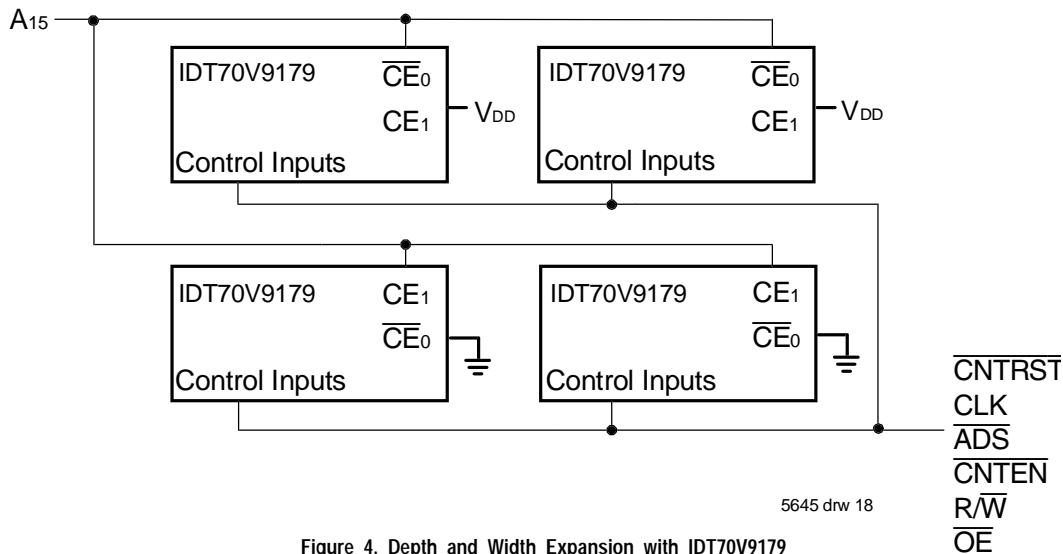
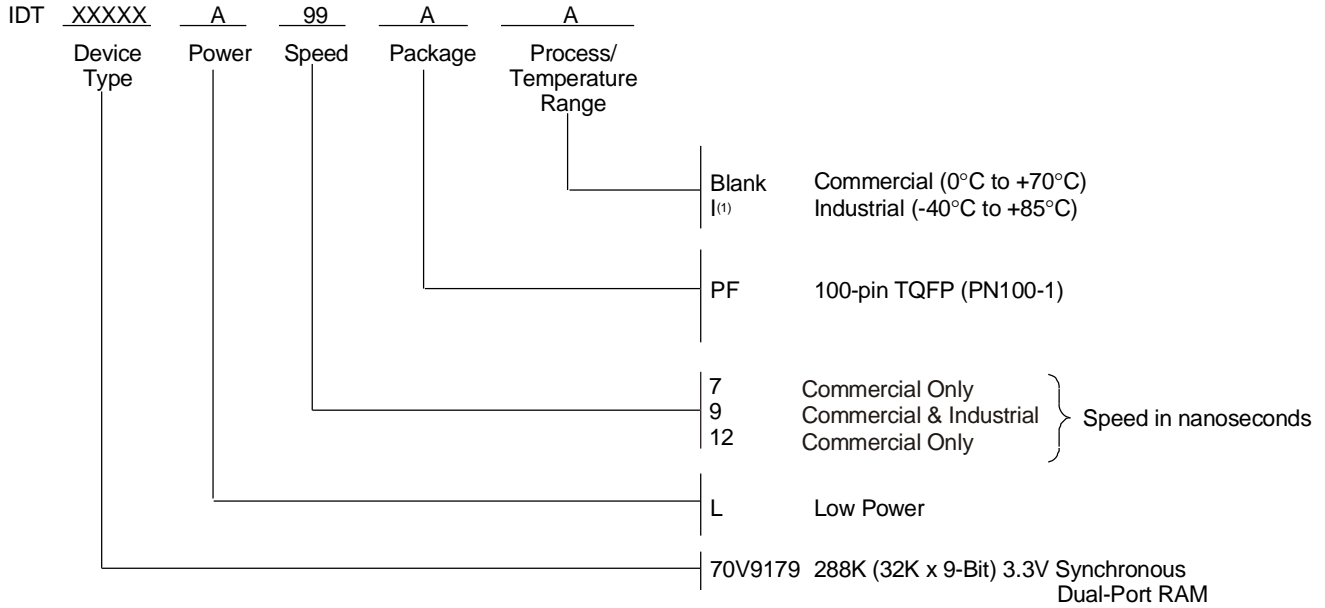

Figure 4. Depth and Width Expansion with IDT70V9179

Ordering Information



5645 drw 19

NOTE:

1. Contact your local sales office for Industrial temp range for other speeds, packages and powers.

Preliminary Datasheet: Definition

"PRELIMINARY" datasheets contain descriptions for products that are in early release.

Datasheet Document History

01/02/02: Initial Data Sheet



CORPORATE HEADQUARTERS
 2975 Stender Way
 Santa Clara, CA 95054

for SALES:
 800-345-7015 or 408-727-6116
 fax: 408-492-8674
 www.idt.com

for Tech Support:
 831-754-4613
 DualPortHelp@idt.com