

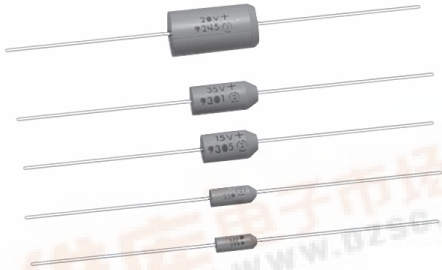

173D

Vishay Sprague

Solid-Electrolyte TANTALEX[®] Capacitors, Axial-Leaded, Molded-Case



FEATURES

- Miniature axial-lead capacitors available in 5 sizes
- Precision molded in gold colored, flame retardant, thermo-setting epoxy resin
- Laser marked for improved legibility and tapered end of case provides easy identification of positive terminal
- Standard orders are lead taped and reeled; orders under 500 are taped only.

APPLICATIONS

- Designed for high performance automotive, industrial and commercial electronic equipment

At + 125°C: Leakage current shall not exceed 15 times the values listed in the Standard Ratings Tables.

Life Test: Capacitors shall withstand rated DC voltage applied at + 85°C for 2000 hours and for 1000 hours applied at + 125°C derated voltage.

Following the life test:

1. DCL shall not exceed 125% of the initial requirement.
2. Dissipation Factor shall meet the initial requirement.
3. Change in capacitance shall not exceed $\pm 10\%$.

PERFORMANCE CHARACTERISTICS

Operating Temperature: - 55°C to + 85°C. (To + 125°C with voltage derating.)

Capacitance Tolerance: At 120 Hz, + 25°C. $\pm 20\%$, $\pm 10\%$ standard. $\pm 5\%$ available as special.

Dissipation Factor: At 120 Hz, + 25°C. Dissipation factor, as determined from the expression $2\pi fRC$, shall not exceed the values listed in the Standard Ratings Tables.

DC Leakage Current (DCL Max.):

At + 25°C: Leakage current shall not exceed the values listed in the Standard Ratings Tables.

At + 85°C: Leakage current shall not exceed 10 times the values listed in the Standard Ratings Tables.

ORDERING INFORMATION

173D MODEL	335 CAPACITANCE	X9 CAPACITANCE TOLERANCE	006 DC VOLTAGE RATING AT + 85°C	U CASE CODE	W PACKAGING
	This is expressed in picofarads. The first two digits are the significant figures. The third is the number of zeros to follow.	X0 = $\pm 20\%$ X9 = $\pm 10\%$ *X5 = $\pm 5\%$ *Special order	This is expressed in volts. To complete the three-digit block, zeros precede the voltage rating.	See Ratings and Case Codes Table.	W = Tape and reel.

DIMENSIONS in inches [millimeters]

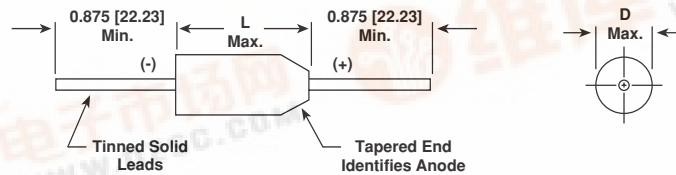

CASE CODE	D (MAX.)	L (MAX.)	LEAD DIAMETER
U	0.095 [2.41]	0.260 [6.60]	0.020 [0.51]
V	0.110 [2.79]	0.290 [7.37]	0.020 [0.51]
W	0.180 [4.57]	0.345 [8.76]	0.020 [0.51]
X	0.180 [4.57]	0.420 [10.67]	0.020 [0.51]
Y	0.280 [7.11]	0.550 [13.97]	0.025 [0.64]



173D

Vishay Sprague

Solid-Electrolyte TANTALEX[®] Capacitors,
Axial-Leaded, Molded-Case



STANDARD RATINGS

CAPACITANCE (μ F)	CASE CODE	PART NUMBER* CAP. TOL. \pm 20%	PART NUMBER* CAP. TOL. \pm 10%	MAX. DCL @ + 25°C (μ A)	MAX. DF @ + 25°C 120 Hz (%)
2 WVDC @ + 85°C, SURGE = 2.5 V . . . 1.5 WVDC @ + 125°C, SURGE = 1.8 V					
6.8	U	173D685X0002U	173D685X9002U	0.5	10
8.2	U	—	173D825X9002U	0.5	10
10.0	U	173D106X0002U	173D106X9002U	0.5	10
12.0	V	—	173D126X9002V	0.5	10
15.0	V	173D156X0002V	173D156X9002V	0.5	10
18.0	V	—	173D186X9002V	0.5	10
22.0	V	173D226X0002V	173D226X9002V	0.5	10
27.0	V	—	173D276X9002V	0.5	10
33.0	V	173D336X0002V	173D336X9002V	0.5	10
39.0	W	—	173D396X9002W	0.6	10
47.0	W	173D476X0002W	173D476X9002W	0.8	10
56.0	W	—	173D566X9002W	0.9	10
68.0	W	173D686X0002W	173D686X9002W	1.1	10
4 WVDC @ + 85°C, SURGE = 5 V . . . 2.5 WVDC @ + 125°C, SURGE = 3 V					
4.7	U	173D475X0004U	173D475X9004U	0.5	8
5.6	U	—	173D565X9004U	0.5	8
6.8	U	173D685X0004U	173D685X9004U	0.5	8
8.2	V	—	173D825X9004V	0.5	8
10.0	V	173D106X0004V	173D106X9004V	0.5	8
12.0	V	—	173D126X9004V	0.5	8
15.0	V	173D156X0004V	173D156X9004V	0.5	8
18.0	V	—	173D186X9004V	0.6	8
22.0	V	173D226X0004V	173D226X9004V	0.7	8
27.0	W	—	173D276X9004W	0.9	8
33.0	W	173D336X0004W	173D336X9004W	1.1	8
39.0	W	—	173D396X9004W	1.2	8
47.0	W	173D476X0004W	173D476X9004W	1.5	8
56.0	X	—	173D566X9004X	1.5	8
68.0	X	173D686X0004X	173D686X9004X	2.2	8
6 WVDC @ + 85°C, SURGE = 8 V . . . 4 WVDC @ + 125°C, SURGE = 5 V					
3.3	U	173D335X0006U	173D335X9006U	0.5	4
3.9	U	—	173D395X9006U	0.5	4
4.7	U	173D475X0006U	173D475X9006U	0.5	4
5.6	V	—	173D565X9006V	0.5	4
6.8	V	173D685X0006V	173D685X9006V	0.5	6
8.2	V	—	173D825X9006V	0.5	6
10.0	V	173D106X0006V	173D106X9006V	0.5	6
12.0	V	—	173D126X9006V	0.6	6
15.0	V	173D156X0006V	173D156X9006V	0.7	6
18.0	W	—	173D186X9006W	0.9	6
22.0	W	173D226X0006W	173D226X9006W	1.1	6
27.0	W	—	173D276X9006W	1.3	6
33.0	W	173D336X0006W	173D336X9006W	1.5	6
39.0	X	—	173D396X9006X	1.9	6
47.0	X	173D476X9006X	173D476X9006X	2.3	6
56.0	X	—	173D566X9006X	2.7	6
68.0	X	173D686X0006X	173D686X9006X	3.3	6
82.0	Y	—	173D826X9006Y	3.9	8
100.0	Y	173D107X0006Y	173D107X9006Y	4.8	8
120.0	Y	—	173D127X9006Y	5.0	8
150.0	Y	173D157X0006Y	173D157X9006Y	5.0	8
180.0	Y	—	173D187X9006Y	8.6	8
220.0	Y	173D227X0006Y	173D227X9006Y	10.0	8
270.0	Y	—	173D277X9006Y	10.0	8
330.0	Y	173D337X0006Y	173D337X9006Y	10.0	8

*Part number should include "X5" for \pm 5% units (special order).



173D

Solid-Electrolyte TANTALEX[®] Capacitors,
Axial-Leaded, Molded-Case

Vishay Sprague

STANDARD RATINGS					
CAPACITANCE (μ F)	CASE CODE	PART NUMBER* CAP. TOL. \pm 20%	PART NUMBER* CAP. TOL. \pm 10%	MAX. DCL @ + 25°C (μ A)	MAX. DF @ + 25°C 120 Hz (%)
10 WVDC @ + 85°C, SURGE = 13 V . . . 7 WVDC @ + 125°C, SURGE = 9 V					
2.2	U	173D225X0010U	173D225X9010U	0.5	4
2.7	U	—	173D275X9010U	0.5	4
3.3	U	173D335X0010U	173D335X9010U	0.5	4
3.9	V	—	173D395X9010V	0.5	4
4.7	V	173D475X0010V	173D475X9010V	0.5	4
5.6	V	—	173D565X9010V	0.5	4
6.8	V	173D685X0010V	173D685X9010V	0.5	6
8.2	V	—	173D825X9010V	0.7	6
10.0	V	173D106X0010V	173D106X9010V	0.8	6
12.0	W	—	173D126X9010W	1.0	6
15.0	W	173D156X0010W	173D156X9010W	1.2	6
18.0	W	—	173D186X9010W	1.4	6
22.0	W	173D226X0010W	173D226X9010W	1.5	6
27.0	X	—	173D276X9010X	2.2	6
33.0	X	173D336X0010X	173D336X9010X	2.6	6
39.0	X	—	173D396X9010X	3.1	6
47.0	X	173D476X0010X	173D476X9010X	3.8	6
56.0	Y	—	173D566X9010Y	4.4	6
68.0	Y	173D686X0010Y	173D686X9010Y	5.0	6
82.0	Y	—	173D826X9010Y	5.0	8
100.0	Y	173D107X0010Y	173D107X9010Y	8.0	8
120.0	Y	—	173D127X9010Y	9.6	8
150.0	Y	173D157X0010Y	173D157X9010Y	10.0	8
180.0	Y	—	173D187X9010Y	10.0	8
220.0	Y	173D227X0010Y	173D227X9010Y	10.0	8
15 WVDC @ + 85°C, SURGE = 20 V . . . 10 WVDC @ + 125°C, SURGE = 12 V					
1.5	U	173D155X0015U	173D155X9015U	0.5	4
1.8	U	—	173D185X9015U	0.5	4
2.2	U	173D225X0015U	173D225X9015U	0.5	4
2.7	V	—	173D275X9015V	0.5	4
3.3	V	173D335X0015V	173D335X9015V	0.5	4
3.9	V	—	173D395X9015V	0.5	4
4.7	V	173D475X0015V	173D475X9015V	0.6	4
5.6	V	—	173D565X9015V	0.7	4
6.8	V	173D685X0015V	173D685X9015V	0.8	6
8.2	W	—	173D825X9015W	1.0	6
10.0	W	173D106X0015W	173D106X9015W	1.2	6
12.0	W	—	173D126X9015W	1.4	6
15.0	W	173D156X0015W	173D156X9015W	1.5	6
18.0	X	—	173D186X9015X	2.2	6
22.0	X	173D226X9015X	173D226X9015X	2.6	6
27.0	X	—	173D276X9015X	3.2	6
33.0	X	173D336X0015X	173D336X9015X	4.0	6
39.0	Y	—	173D396X9015Y	4.7	6
47.0	Y	173D476X0015Y	173D476X9015Y	5.0	6
56.0	Y	—	173D566X9015Y	6.7	6
68.0	Y	173D686X0015Y	173D686X9015Y	8.2	6
82.0	Y	—	173D826X9015Y	9.8	8
100.0	Y	173D107X0015Y	173D107X9015Y	10.0	8
120.0	Y	—	173D127X9015Y	10.0	8
150.0	Y	173D157X0015Y	173D157X9015Y	10.0	8

*Part number should include "X5" for \pm 5% units (special order).

173D

Vishay Sprague

Solid-Electrolyte TANTALEX[®] Capacitors,
Axial-Leaded, Molded-Case



STANDARD RATINGS

CAPACITANCE (μ F)	CASE CODE	PART NUMBER* CAP. TOL. \pm 20%	PART NUMBER* CAP. TOL. \pm 10%	MAX. DCL @ + 25°C (μ A)	MAX. DF @ + 25°C 120 Hz (%)
20 WVDC @ + 85°C, SURGE = 26 V . . . 13 WVDC @ + 125°C, SURGE = 16 V					
1.0	U	173D105X0020U	173D105X9020U	0.5	4
1.2	U	—	173D125X9020U	0.5	4
1.5	U	173D155X0020U	173D155X9020U	0.5	4
1.8	V	—	173D185X9020V	0.5	4
2.2	V	173D225X0020V	173D225X9020V	0.5	4
2.7	V	—	173D275X9020V	0.5	4
3.3	V	173D335X0020V	173D335X9020V	0.5	4
3.9	V	—	173D395X9020V	0.6	4
4.7	V	173D475X0020V	173D475X9020V	0.8	4
5.6	W	—	173D565X9020W	0.9	4
6.8	W	173D685X0020W	173D685X9020W	1.1	6
8.2	W	—	173D825X9020W	1.3	6
10.0	W	173D106X0020W	173D106X9020W	1.6	6
12.0	X	—	173D126X9020X	1.9	6
15.0	X	173D156X0020X	173D156X9020X	2.4	6
18.0	X	—	173D186X9020X	2.9	6
22.0	X	173D226X0020X	173D226X9020X	3.5	6
27.0	Y	—	173D276X9020Y	4.3	6
33.0	Y	173D336X0020Y	173D336X9020Y	5.0	6
39.0	Y	—	173D396X9020Y	6.2	6
47.0	Y	173D476X0020Y	173D476X9020Y	7.5	6
56.0	Y	—	173D566X9020Y	8.9	6
68.0	Y	173D686X0020Y	173D686X9020Y	10.0	6
82.0	Y	—	173D826X9020Y	10.0	6
100.0	Y	173D107X0020Y	173D107X9020Y	10.0	6
25 WVDC @ + 85°C, SURGE = 32 V . . . 17 WVDC @ + 125°C, SURGE = 21 V					
0.47	U	173D474X0025U	173D474X9025U	0.5	3
0.56	U	—	173D564X9025U	0.5	3
0.68	U	173D684X0025U	173D684X9025U	0.5	3
0.82	U	—	173D824X9025U	0.5	3
1.0	U	173D105X0025U	173D105X9025U	0.5	3
1.2	V	—	173D125X9025V	0.5	3
1.5	V	173D155X0025V	173D155X9025V	0.5	3
1.8	V	—	173D185X9025V	0.5	3
2.2	V	173D225X0025V	173D225X9025V	0.5	3
2.7	V	—	173D275X9025V	0.5	3
3.3	V	173D335X0025V	173D335X9025V	0.7	3
3.9	W	—	173D395X9025W	0.8	3
4.7	W	173D475X0025W	173D475X9025W	0.9	4
5.6	W	—	173D565X9025W	1.1	4
6.8	W	173D685X0025W	173D685X9025W	1.4	4
8.2	W	—	173D825X9025W	1.5	4
10.0	W	173D106X0025W	173D106X9025W	1.5	4
12.0	X	—	173D126X9025X	2.4	4
15.0	X	173D156X0025X	173D156X9025X	3.0	4
18.0	Y	—	173D186X9025Y	3.6	6
22.0	Y	173D226X9025Y	173D226X9025Y	4.4	6
27.0	Y	—	173D276X9025Y	5.4	6
33.0	Y	173D336X0025Y	173D336X9025Y	6.6	6
39.0	Y	—	173D396X9025Y	7.8	6
47.0	Y	173D476X0025Y	173D476X9025Y	9.4	6

*Part number should include "X5" for \pm 5% units (special order).



173D

Solid-Electrolyte TANTALEX[®] Capacitors,
Axial-Leaded, Molded-Case

Vishay Sprague

STANDARD RATINGS						
CAPACITANCE (μ F)	CASE CODE	PART NUMBER* CAP. TOL. \pm 20%	PART NUMBER* CAP. TOL. \pm 10%	MAX. DCL @ + 25°C (μ A)	MAX. DF @ + 25°C 120 Hz (%)	
35 WVDC @ + 85°C, SURGE = 46 V . . . 23 WVDC @ + 125°C, SURGE = 28 V						
0.10	U	173D104X0035U	173D104X9035U	0.5	3	
0.12	U	—	173D124X9035U	0.5	3	
0.15	U	173D154X0035U	173D154X9035U	0.5	3	
0.18	U	—	173D184X9035U	0.5	3	
0.22	U	173D224X0035U	173D224X9035U	0.5	3	
0.27	U	—	173D274X9035U	0.5	3	
0.33	U	173D334X0035U	173D334X9035U	0.5	3	
0.39	U	—	173D394X9035U	0.5	3	
0.47	U	173D474X0035U	173D474X9035U	0.5	3	
0.56	V	—	173D564X9035V	0.5	3	
0.68	V	173D684X0035V	173D684X9035V	0.5	3	
0.82	V	—	173D824X9035V	0.5	3	
1.0	V	173D105X0035V	173D105X9035V	0.5	3	
1.2	V	—	173D125X9035V	0.5	3	
1.5	V	173D155X0035V	173D155X9035V	0.5	3	
1.8	W	—	173D185X9035W	0.5	3	
2.2	W	173D225X0035V	173D225X9035V	0.6	3	
2.7	W	—	173D275X9035W	0.8	3	
3.3	W	173D335X0035W	173D335X9035W	0.9	4	
3.9	W	—	173D395X9035W	1.1	4	
4.7	W	173D475X0035W	173D475X9035W	1.3	4	
5.6	X	—	173D565X9035X	1.6	4	
6.8	X	173D685X0035X	173D685X9035X	1.9	4	
8.2	X	—	173D825X9035X	2.3	4	
10.0	X	173D106X0035X	173D106X9035X	2.8	4	
35 WVDC @ + 85°C, SURGE = 46 V . . . 23 WVDC @ + 125°C, SURGE = 28 V						
12.0	Y	—	173D126X9035Y	3.3	4	
15.0	Y	173D156X0035Y	173D156X9035Y	4.2	6	
18.0	Y	—	173D186X9035Y	5.0	6	
22.0	Y	173D226X0035Y	173D226X9035Y	6.2	6	
27.0	Y	—	173D276X9035Y	7.5	6	
33.0	Y	173D336X0035Y	173D336X9035Y	9.2	6	
39.0	Y	—	173D396X9035Y	10.0	6	
47.0	Y	173D476X0035Y	173D476X9035Y	10.0	6	
50 WVDC @ + 85°C, SURGE = 65 V . . . 33 WVDC @ + 125°C, SURGE = 40 V						
0.10	U	173D104X0050U	173D104X9050U	0.5	3	
0.12	U	—	173D124X9050U	0.5	3	
0.15	U	173D154X0050U	173D154X9050U	0.5	3	
0.18	U	—	173D184X9050U	0.5	3	
0.22	U	173D224X0050U	173D224X9050U	0.5	3	
0.27	U	—	173D274X9050U	0.5	3	
0.33	V	173D334X0050V	173D334X9050V	0.5	3	
0.39	V	—	173D394X9050V	0.5	3	
0.47	V	173D474X0050V	173D474X9050V	0.5	3	
0.56	V	—	173D564X9050V	0.5	3	
0.68	V	173D684X0050V	173D684X9050V	0.5	3	
0.82	V	—	173D824X9050V	0.5	3	
1.0	V	173D105X0050V	173D105X9050V	0.5	3	
1.2	W	—	173D125X9050W	0.5	3	
1.5	W	173D155X0050W	173D155X9050W	0.6	4	
1.8	W	—	173D185X9050W	0.7	4	
2.2	W	173D225X0050W	173D225X9050W	0.9	4	
2.7	X	—	173D275X9050X	1.1	4	
3.3	X	173D335X0050X	173D335X9050X	1.3	4	
3.9	X	—	173D395X9050X	1.6	4	
4.7	X	173D475X0050X	173D475X9050X	1.9	4	
5.6	Y	—	173D565X9050Y	2.2	4	
6.8	Y	173D685X0050Y	173D685X9050Y	2.7	4	
8.2	Y	—	173D825X9050Y	3.2	4	
10.0	Y	173D106X0050Y	173D106X9050Y	4.0	6	
12.0	Y	—	173D126X9050Y	5.0	6	
15.0	Y	173D156X0050Y	173D156X9050Y	6.0	6	
18.0	Y	—	173D186X9050Y	6.0	6	

*Part number should include "X5" for \pm 5% units (special order).



TAPE AND REEL PACKAGING in inches [millimeters]

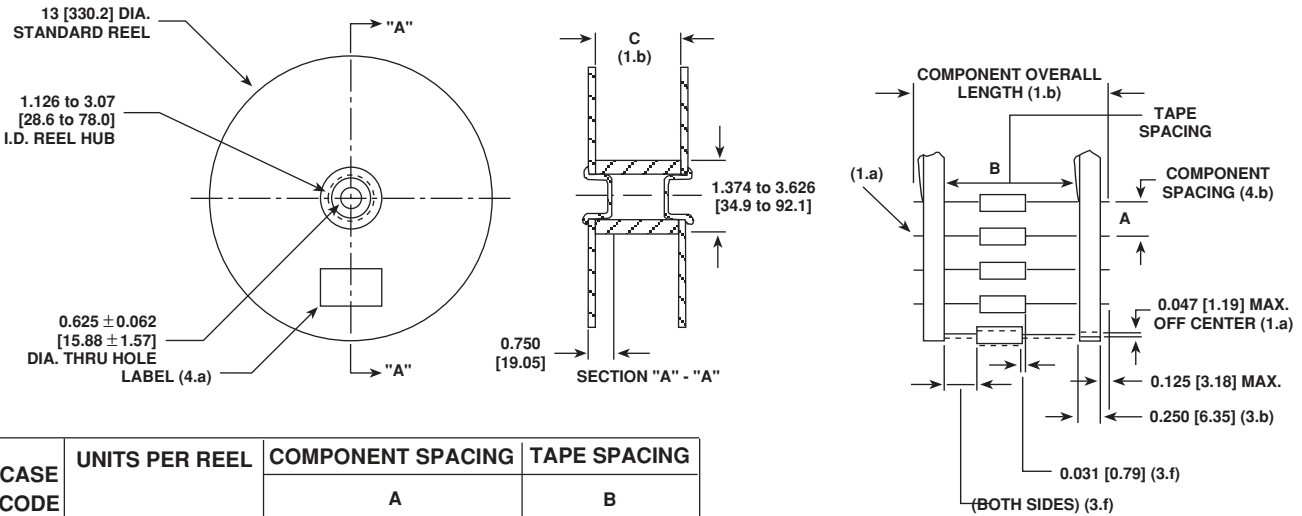

CASE CODE	UNITS PER REEL	COMPONENT SPACING	TAPE SPACING
		A	B
U	4500	0.200 ± 0.015 [5.08 ± 3.81]	2.062 ± 0.062 [52.37 ± 1.57]
V	4000		
W, X	2500		
Y	500	0.400 ± 0.015 [10.16 ± 3.81]	

STANDARD REEL PACKAGING INFORMATION

1. Component Leads:

- a. Component leads shall not be bent beyond 0.047" [1.19mm] maximum from their nominal position when measured from the leading edge of the component lead at the inside tape edge and at the lead egress from the component.
- b. The 'C' dimension shall be governed by the overall length of the reel packaged component. The distance between flanges shall be 0.125" to 0.250" [3.18mm to 6.35mm] greater than the overall component length.

2. Orientation:

- a. All polarized components must be oriented to one direction. The cathode lead tape shall be a color and the anode lead tape shall be white.

3. Reeling:

- a. Components on any reel shall not represent more than two date codes when date code identification is required.
- b. Component leads shall be positioned between pairs of 0.250" [6.35mm] tape.
- c. The disposable reels have hubs with corrugated fiber board flanges and core.
- d. A minimum of 12" [304.8mm] leader of tape shall be provided before the first and after the last component on the reel.
- e. 50 to 60 lb. Kraft paper must be wound between layers of components as far as necessary for component protection. Width of paper to be 0.062" to 0.250" [1.57mm to 6.35mm] less than the 'C' dimension of the reel.

- f. Row components must be centered between tapes ± 0.047" [1.19mm]. In addition, individual components may deviate from center of component row ± 0.031" [0.79].
- g. Staples shall not be used for splicing. Not more than 4 layers of tape shall be used in any splice area and no tape shall be offset from another by more than 0.031" [0.79mm] non-cumulative. Tape splices shall overlap at least 6" [152.4mm] for butt joints and at least 3" [76.2mm] for lap joints and shall not be weaker than unspliced tape. Universal splicing clips may also be used.
- h. Quantity per reel shall be controlled so that tape components and cover shall not extend beyond the smallest dimension of the flange (either across flats or diameter). Once the quantity per reel for each part number has been established, future orders for that part number shall be packaged in that quantity. When order release quantity is less than the established quantity, a standard commercial pack is to be used.
- i. A maximum of 0.25% of the components per reel quantity may be missing without consecutive missing components.
- j. Adequate protection must be provided to prevent physical damage to both reel and components during shipment and storage.

4. Marking:

- a. Minimum reel and carton marking shall consist of the following: Customer Part Number, Purchase Order No., Quantity, Package Date, Manufacturer's name, Electrical Value, Date Code, Vishay Sprague Part Number and Country of Origin.