

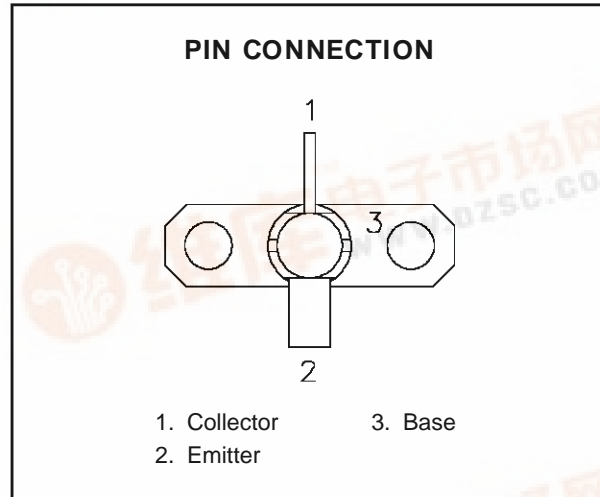

SD1893-03

**RF & MICROWAVE TRANSISTORS
1.6 GHZ SATCOM APPLICATIONS**

- 1.65 GHz
- 28 VOLTS
- OVERLAY DIE GEOMETRY
- GOLD METALLIZATION
- HIGH RELIABILITY AND RUGGEDNESS
- P_{OUT} = 10 W MIN. WITH 11.0 dB GAIN
- COMMON BASE

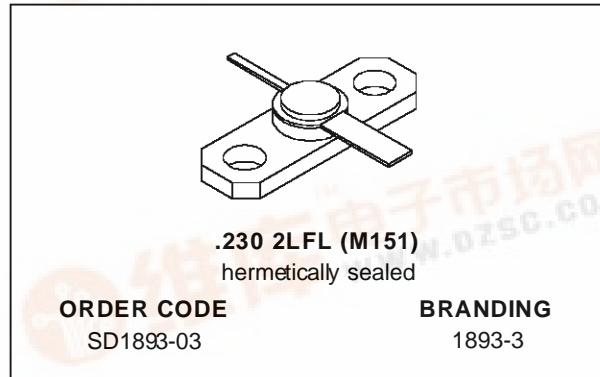

DESCRIPTION

The SD1893-03 is a 28 V silicon NPN planar transistor designed for INMARSAT and other 1.6 GHz SATCOM applications. The device utilizes polysilicon site ballasting with a gold metallized die to achieve high reliability and ruggedness.

ABSOLUTE MAXIMUM RATINGS (T_{case} = 25°C)

Symbol	Parameter	Value	Unit
V _{CBO}	Collector-Base Voltage	45	V
V _{CEO}	Collector-Emitter Voltage	15	V
V _{EBO}	Emitter-Base Voltage	3.5	V
I _C	Device Current	4.4	A
P _{DISS}	Power Dissipation	43	W
T _J	Junction Temperature	+200	°C
T _{STG}	Storage Temperature	- 65 to +200	°C

THERMAL DATA

R _{TH(j-c)}	Junction-Case Thermal Resistance	5.5	°C/W
----------------------	----------------------------------	-----	------



SD1893-03**ELECTRICAL SPECIFICATIONS** ($T_{\text{case}} = 25^{\circ}\text{C}$)

STATIC

Symbol	Test Conditions			Value			Unit
				Min.	Typ.	Max.	
BV_{CBO}	$I_{\text{C}} = 3\text{mA}$	$I_{\text{E}} = 0\text{mA}$	45	—	—	V	
BV_{EBO}	$I_{\text{E}} = 3\text{mA}$	$I_{\text{C}} = 0\text{mA}$	3.5	—	—	V	
I_{CBO}	$V_{\text{CB}} = 28\text{V}$	$I_{\text{E}} = 0\text{mA}$	—	—	5	mA	
h_{FE}	$V_{\text{CE}} = 5\text{V}$	$I_{\text{C}} = 300\text{mA}$	15	—	150	—	

DYNAMIC

Symbol	Test Conditions			Value			Unit
				Min.	Typ.	Max.	
P_{OUT}	$f = 1.65\text{ GHz}$	$P_{\text{IN}} = 0.6\text{ W}$	$V_{\text{CE}} = 28\text{ V}$	10	—	—	W
G_{P}	$f = 1.65\text{ GHz}$	$P_{\text{IN}} = 0.6\text{ W}$	$V_{\text{CE}} = 28\text{ V}$	11	—	—	dB
η_{c}	$f = 1.65\text{ GHz}$	$P_{\text{IN}} = 0.6\text{ W}$	$V_{\text{CE}} = 28\text{ V}$	45	—	—	%
C_{OB}	$f = 1\text{ MHz}$	$V_{\text{CB}} = 28\text{ V}$		—	19	—	pF

IMPEDANCE DATA

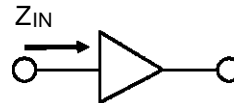
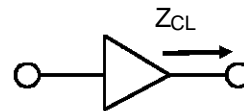
TYPICAL INPUT
IMPEDANCETYPICAL COLLECTOR
LOAD IMPEDANCE

FREQ.	Z_{IN} (Ω)	Z_{CL} (Ω)
1.5 GHz	$2.5 + j 4.5$	$3.5 - j 2.6$
1.6 GHz	$2.0 + j 6.0$	$3.0 - j 3.3$
1.7 GHz	$2.0 + j 7.0$	$3.5 - j 4.0$

SD1893-03

TEST CIRCUIT

C1, C2 : .4 - 2.5pF Johanson Capacitor #27283
C3 : 100pF Chip Capacitor ATC 100 A101KCA 150
C4 : 15,000pF EMI Filter Murata/Erie 9900-381-6004

L1, L2 : 4 Turn, Choke #28 AWG .080" I.D.

Board
Material: Epsilam 10, Er = 10.2, H = .050"
1 Oz. Cu. SMA Launcher CDI (2 poeces)
.230" Fixture Housing Heatsink, Advanced Corp. 5308-2CC

PACKAGE MECHANICAL DATA

Ref.: Dwg. No.12-0151

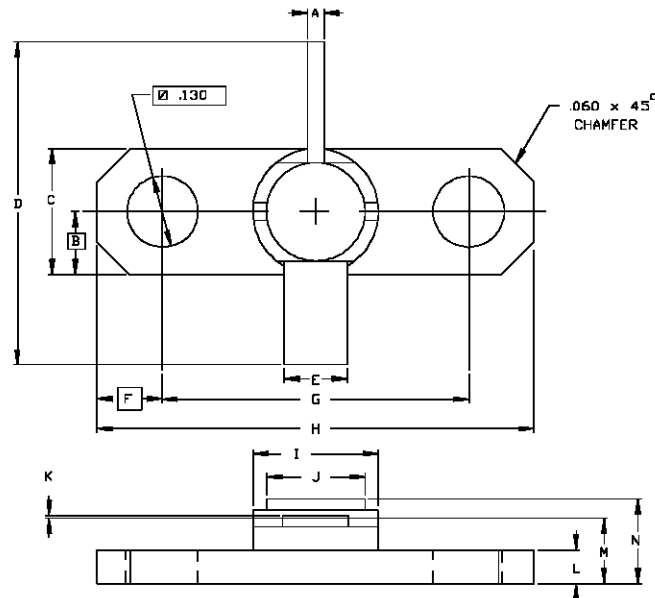

SGS-THOMSON MICROELECTRONICS			CONT'D		
	MINIMUM Inches/mm	MAXIMUM Inches/mm		MINIMUM Inches/mm	MAXIMUM Inches/mm
A	.025/0,64	.035/0,89	K	.003/0,08	.007/0,18
B	.115/2,92	NDM.	L	.055/1,40	.067/1,70
C	.225/5,72	.235/5,97	M	.120/3,18	.140/3,56
D	.710/18,03	.750/19,05	N		.170/4,32
E	.110/2,79	.120/3,05			
F	.120/3,05	NDM.			
G	.555/14,10	.565/14,35			
H	.795/20,19	.805/20,45			
I	.222/5,64	.236/5,99			
J	.165/4,19	.185/4,70			

Information furnished is believed to be accurate and reliable. However, SGS-THOMSON Microelectronics assumes no responsibility for the consequences of use of such information nor for any infringement of patents or other rights of third parties which may result from its use. No license is granted by implication or otherwise under any patent or patent rights of SGS-THOMSON Microelectronics. Specifications mentioned in this publication are subject to change without notice. This publication supersedes and replaces all information previously supplied. SGS-THOMSON Microelectronics products are not authorized for use as critical components in life support devices or systems without express written approval of SGS-THOMSON Microelectronics.

© 1994 SGS-THOMSON Microelectronics - All Rights Reserved

SGS-THOMSON Microelectronics GROUP OF COMPANIES
 Australia - Brazil - France - Germany - Hong Kong - Italy - Japan - Korea - Malaysia - Malta - Morocco - The Netherlands -
 Singapore - Spain - Sweden - Switzerland - Taiwan - Thailand - United Kingdom - U.S.A