



**PRELIMINARY**

## CY14B104L, CY14B104N

# 4-Mbit (512K x 8/256K x 16) nvSRAM

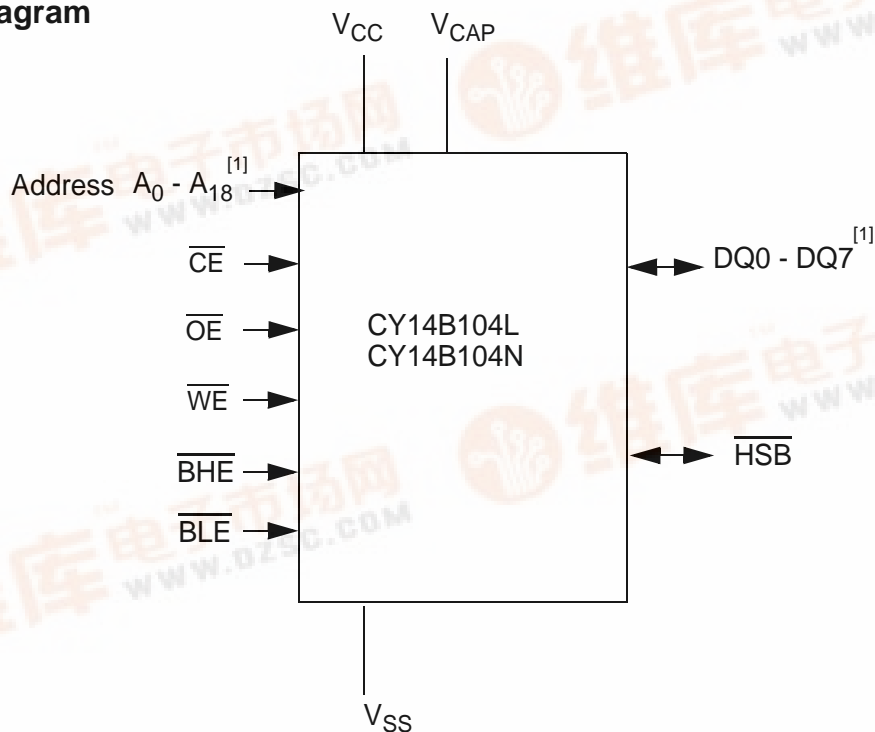
### Features

- 15 ns, 25 ns, and 45 ns access times
- Internally organized as 512K x 8 (CY14B104L) or 256K x 16 (CY14B104N)
- Hands off automatic STORE on power down with only a small capacitor
- STORE to QuantumTrap® nonvolatile elements initiated by software, device pin or AutoStore® on power down
- RECALL to SRAM initiated by software or power up
- Infinite read, write, and recall cycles
- 8 mA typical I<sub>CC</sub> at 200 ns cycle time
- 200,000 STORE cycles to QuantumTrap
- 20 year data retention
- Single 3V +20%, -10% operation
- Commercial and industrial temperatures
- FBGA and TSOP - II packages
- RoHS compliance

### Functional Description

The Cypress CY14B104L/CY14B104N is a fast static RAM, with a nonvolatile element in each memory cell. The memory is organized as 512K words of 8 bits each or 256K words of 16 bits each. The embedded nonvolatile elements incorporate QuantumTrap technology, producing the world's most reliable nonvolatile memory. The SRAM provides infinite read and write cycles, while independent nonvolatile data resides in the highly reliable QuantumTrap cell. Data transfers from the SRAM to the nonvolatile elements (the STORE operation) takes place automatically at power down. On power up, data is restored to the SRAM (the RECALL operation) from the nonvolatile memory. Both the STORE and RECALL operations are also available under software control.

### Logic Block Diagram

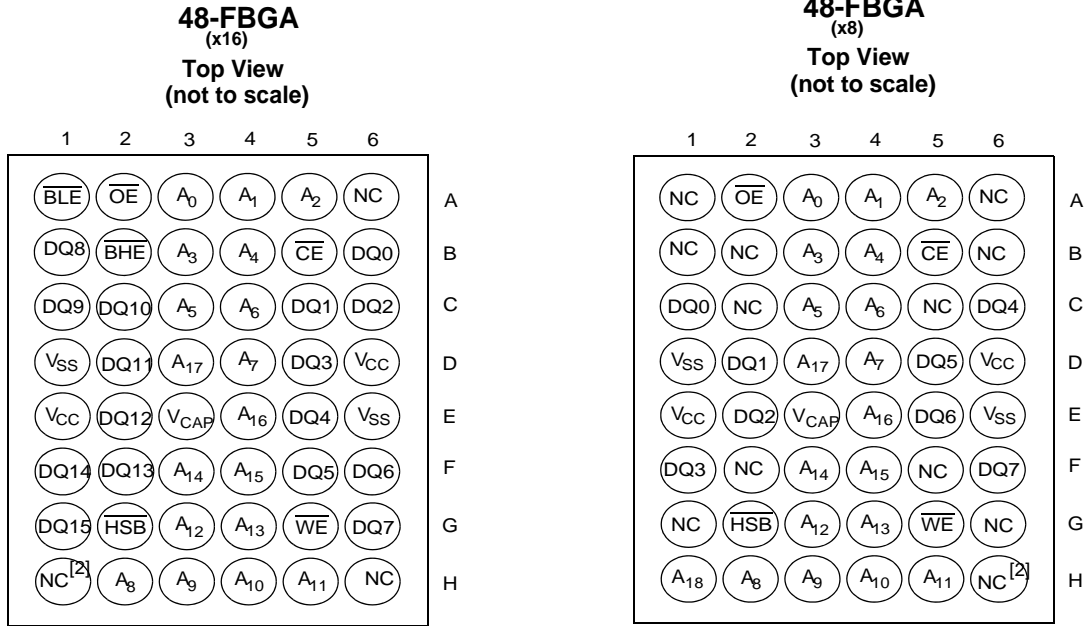


Note  
1. Address A<sub>0</sub> - A<sub>18</sub> and Data DQ<sub>0</sub> - DQ<sub>7</sub> for x8 configuration, Address A<sub>0</sub> - A<sub>17</sub> and Data DQ<sub>0</sub> - DQ<sub>15</sub> for x16 configuration.

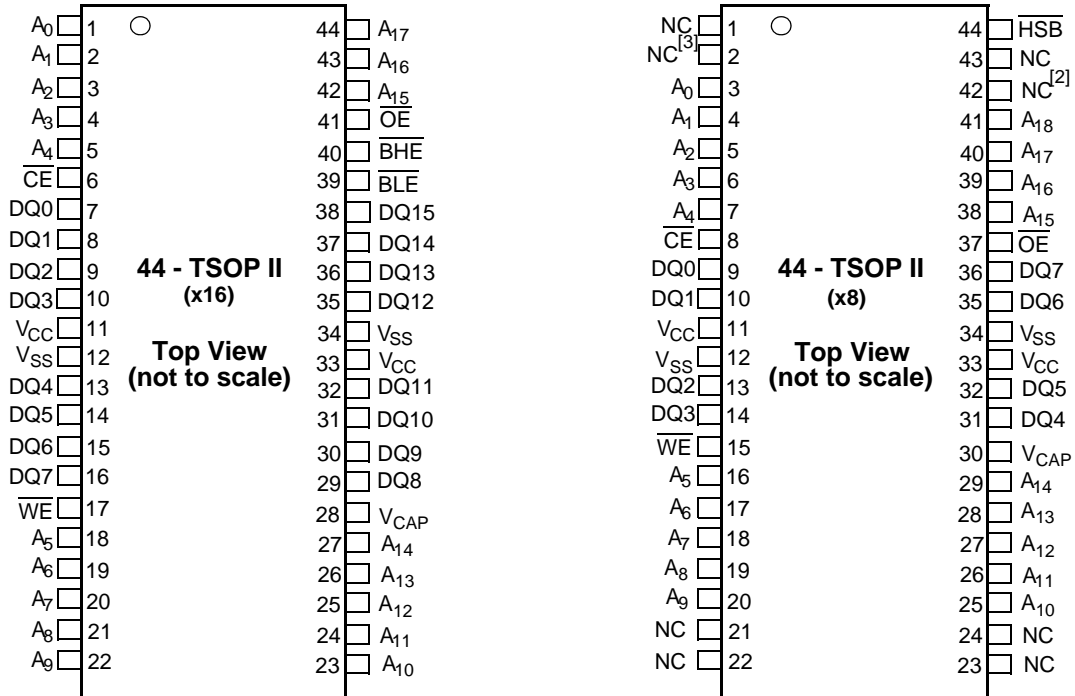


**Pinouts**

**Figure 1. Pin Diagram - 48 FBGA**



**Figure 2. Pin Diagram - 44 TSOP II**

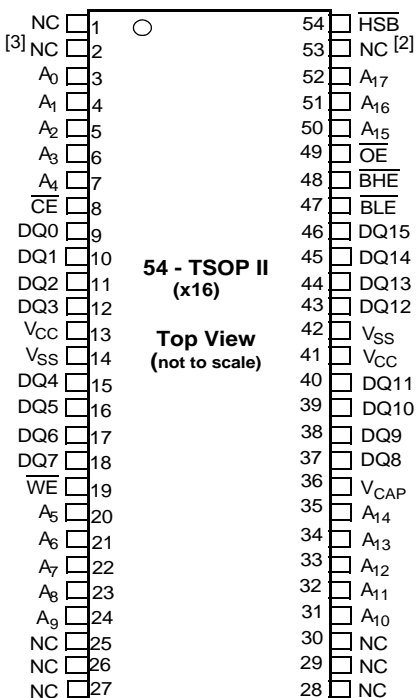


**Notes**

- 2. Address expansion for 8 Mbit. NC pin not connected to die.
- 3. Address expansion for 16 Mbit. NC pin not connected to die.

**Pinouts** (continued)

**Figure 3. Pin Diagram - 54 Pin TSOP II (x16)**



**Pin Definitions**

Pin Name	IO Type	Description
A <sub>0</sub> – A <sub>18</sub>	Input	<b>Address Inputs Used to Select one of the 524, 288 bytes of the nvSRAM for x8 Configuration.</b>
A <sub>0</sub> – A <sub>17</sub>		<b>Address Inputs Used to Select one of the 262,144 bytes of the nvSRAM for x16 Configuration.</b>
DQ <sub>0</sub> – DQ <sub>7</sub>	Input/Output	<b>Bidirectional Data IO Lines for x8 Configuration.</b> Used as input or output lines depending on operation.
DQ <sub>0</sub> – DQ <sub>15</sub>		<b>Bidirectional Data IO Lines for x16 Configuration.</b> Used as input or output lines depending on operation.
$\overline{WE}$	Input	<b>Write Enable Input, Active LOW.</b> When selected LOW, data on the IO pins is written to the address location latched by the falling edge of CE.
$\overline{CE}$	Input	<b>Chip Enable Input, Active LOW.</b> When LOW, selects the chip. When HIGH, deselects the chip.
$\overline{OE}$	Input	<b>Output Enable, Active LOW.</b> The active LOW $\overline{OE}$ input enables the data output buffers during read cycles. IO pins are tri-stated on deasserting $\overline{OE}$ high.
V <sub>SS</sub>	Ground	<b>Ground for the Device.</b> Must be connected to the ground of the system.
V <sub>CC</sub>	Power Supply	<b>Power Supply Inputs to the Device.</b>
$\overline{HSB}$	Input/Output	<b>Hardware Store Busy (HSB).</b> When LOW this output indicates that a hardware store is in progress. When pulled LOW external to the chip it initiates a nonvolatile STORE operation. A weak internal pull up resistor keeps this pin HIGH if not connected (connection optional).
V <sub>CAP</sub>	Power Supply	<b>AutoStore Capacitor.</b> Supplies power to the nvSRAM during power loss to store data from the SRAM to nonvolatile elements.
NC	No Connect	<b>No Connect.</b> Do not connect this pin to the die.

## Device Operation

The CY14B104L/CY14B104N nvSRAM is made up of two functional components paired in the same physical cell. They are an SRAM memory cell and a nonvolatile QuantumTrap cell. The SRAM memory cell operates as a standard fast static RAM. Data in the SRAM is transferred to the nonvolatile cell (the STORE operation), or from the nonvolatile cell to the SRAM (the RECALL operation). Using this unique architecture all cells are stored and recalled in parallel. During the STORE and RECALL operations SRAM read and write operations are inhibited. The CY14B104L/CY14B104N supports infinite reads and writes similar to a typical SRAM. In addition, it provides infinite RECALL operations from the nonvolatile cells and up to 200K STORE operations.

## SRAM Read

The CY14B104L/CY14B104N performs a READ cycle when  $\overline{CE}$  and  $\overline{OE}$  are LOW, and  $\overline{WE}$  and HSB are HIGH. The address specified on pins A<sub>0-18</sub> or A<sub>0-17</sub> determines which of the 524,288 data bytes or 262,144 words of 16 bits each is accessed. When the read is initiated by an address transition, the outputs are valid after a delay of t<sub>AA</sub> (read cycle #1). If the read is initiated by  $\overline{CE}$  or  $\overline{OE}$ , the outputs are valid at t<sub>ACE</sub> or at t<sub>DOE</sub>, whichever is later (read cycle #2). The data outputs repeatedly respond to address changes within the t<sub>AA</sub> access time without the need for transitions on any control input pins. This remains valid until another address change or until  $\overline{CE}$  or  $\overline{OE}$  is brought HIGH, or  $\overline{WE}$  or HSB is brought LOW.

## SRAM Write

A WRITE cycle is performed whenever  $\overline{CE}$  and  $\overline{WE}$  are LOW and HSB is HIGH. The address inputs must be stable before entering the WRITE cycle and must remain stable until either CE or WE goes high at the end of the cycle. The data on the common IO pins DQ<sub>0-15</sub> are written into the memory if the data is valid t<sub>SD</sub> before the end of a WE controlled WRITE or before the end of an CE controlled WRITE. It is recommended that OE be kept HIGH during the entire WRITE cycle to avoid data bus contention on common IO lines. If OE is left LOW, internal circuitry turns off the output buffers t<sub>HZWE</sub> after WE goes LOW.

## AutoStore Operation

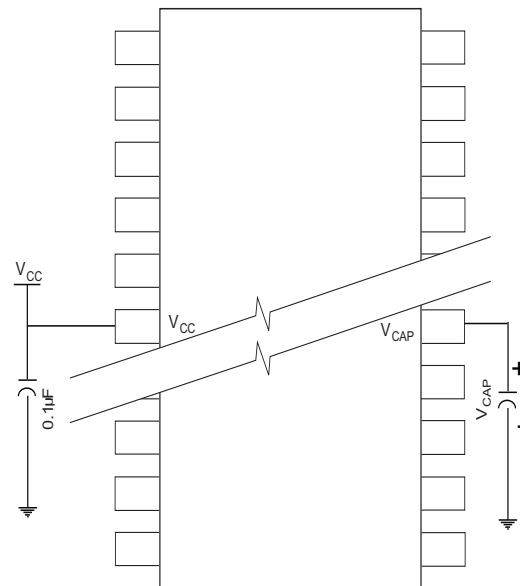
The CY14B104L/CY14B104N stores data to the nvSRAM using one of the following three storage operations: Hardware Store activated by HSB; Software Store activated by an address sequence; AutoStore on device power down. The AutoStore operation is a unique feature of QuantumTrap technology and is enabled by default on the CY14B104L/CY14B104N.

During a normal operation, the device draws current from V<sub>CC</sub> to charge a capacitor connected to the V<sub>CAP</sub> pin. This stored charge is used by the chip to perform a single STORE operation. If the voltage on the V<sub>CC</sub> pin drops below V<sub>SWITCH</sub>, the part automatically disconnects the V<sub>CAP</sub> pin from V<sub>CC</sub>. A STORE operation is initiated with power provided by the V<sub>CAP</sub> capacitor.

Figure 4 shows the proper connection of the storage capacitor (V<sub>CAP</sub>) for automatic store operation. Refer to the section DC Electrical Characteristics on page 7 for the size of V<sub>CAP</sub>.

To reduce unnecessary nonvolatile stores, AutoStore and Hardware Store operations are ignored unless at least one WRITE operation has taken place since the most recent STORE or RECALL cycle. Software initiated STORE cycles are performed regardless of whether a WRITE operation has taken place. Monitor the HSB signal by the system to detect if an AutoStore cycle is in progress.

Figure 4. AutoStore Mode



## Hardware STORE Operation

The CY14B104L/CY14B104N provides the HSB pin for controlling and acknowledging the STORE operations. Use the HSB pin to request a hardware STORE cycle. When the HSB pin is driven LOW, the CY14B104L/CY14B104N conditionally initiates a STORE operation after t<sub>DELAY</sub>. An actual STORE cycle only begins if a WRITE to the SRAM took place since the last STORE or RECALL cycle. The HSB pin also acts as an open drain driver that is internally driven LOW to indicate a busy condition while the STORE (initiated by any means) is in progress.

SRAM READ and WRITE operations that are in progress when HSB is driven LOW by any means are given time to complete before the STORE operation is initiated. After HSB goes LOW, the CY14B104L/CY14B104N continues SRAM operations for t<sub>DELAY</sub>. During t<sub>DELAY</sub>, multiple SRAM READ operations may take place. If a WRITE is in progress when HSB is pulled low it is allowed a time, t<sub>DELAY</sub> to complete. However, any SRAM WRITE cycles requested after HSB goes LOW is inhibited until HSB returns HIGH.

During any STORE operation, regardless of how it was initiated, the CY14B104L/CY14B104N continues to drive the HSB pin LOW, releasing it only when the STORE is complete. Upon completion of the STORE operation, the CY14B104L/CY14B104N remains disabled until the HSB pin returns HIGH. Leave the HSB unconnected if it is not used.



### Hardware RECALL (Power Up)

During power up or after any low power condition ( $V_{CC} < V_{SWITCH}$ ), an internal RECALL request is latched. When  $V_{CC}$  again exceeds the sense voltage of  $V_{SWITCH}$ , a RECALL cycle is automatically initiated and takes  $t_{HRECALL}$  to complete.

### Software STORE

Transfer data from the SRAM to the nonvolatile memory with a software address sequence. The CY14B104L/CY14B104N software STORE cycle is initiated by executing sequential  $\overline{CE}$ -controlled READ cycles from six specific address locations in exact order. During the STORE cycle an erase of the previous nonvolatile data is first performed, followed by a program of the nonvolatile elements. After a STORE cycle is initiated, further input and output are disabled until the cycle is completed.

Because a sequence of READs from specific addresses is used for STORE initiation, it is important that no other READ or WRITE accesses intervene in the sequence. If there are intervening READ or WRITE accesses, the sequence is aborted and no STORE or RECALL takes place.

To initiate the software STORE cycle, the following READ sequence must be performed.

1. Read Address 0x4E38 Valid READ
2. Read Address 0xB1C7 Valid READ
3. Read Address 0x83E0 Valid READ
4. Read Address 0x7C1F Valid READ
5. Read Address 0x703F Valid READ
6. Read Address 0x8FC0 Initiate STORE Cycle

The software sequence may be clocked with  $\overline{CE}$  controlled READs or  $\overline{OE}$  controlled READs. After the sixth address in the sequence is entered, the STORE cycle commences and the chip is disabled. It is important to use READ cycles and not WRITE cycles in the sequence, although it is not necessary that  $\overline{OE}$  be LOW for a valid sequence. After the  $t_{STORE}$  cycle time is fulfilled, the SRAM is activated again for the READ and WRITE operation.

### Software RECALL

Transfer the data from the nonvolatile memory to the SRAM with a software address sequence. A software RECALL cycle is initiated with a sequence of READ operations in a manner similar to the software STORE initiation. To initiate the RECALL cycle, the following sequence of  $\overline{CE}$  controlled READ operations must be performed.

1. Read Address 0x4E38 Valid READ
2. Read Address 0xB1C7 Valid READ
3. Read Address 0x83E0 Valid READ
4. Read Address 0x7C1F Valid READ
5. Read Address 0x703F Valid READ
6. Read Address 0x4C63 Initiate RECALL Cycle

Internally, RECALL is a two step procedure. First, the SRAM data is cleared and then, the nonvolatile information is transferred into the SRAM cells. After the  $t_{RECALL}$  cycle time, the SRAM is again ready for READ and WRITE operations. The RECALL operation does not alter the data in the nonvolatile elements.

Table 1. Mode Selection

$\overline{CE}$	$\overline{WE}$	$\overline{OE}$	A15 - A0	Mode	IO	Power
H	X	X	X	Not Selected	Output High Z	Standby
L	H	L	X	Read SRAM	Output Data	Active
L	L	X	X	Write SRAM	Input Data	Active
L	H	L	0x4E38 0xB1C7 0x83E0 0x7C1F 0x703F 0x8B45	Read SRAM Read SRAM Read SRAM Read SRAM Read SRAM AutoStore Disable	Output Data Output Data Output Data Output Data Output Data Output Data	Active <sup>[4,5,6]</sup>
L	H	L	0x4E38 0xB1C7 0x83E0 0x7C1F 0x703F 0x4B46	Read SRAM Read SRAM Read SRAM Read SRAM Read SRAM AutoStore Enable	Output Data Output Data Output Data Output Data Output Data Output Data	Active <sup>[4,5,6]</sup>

Notes

4. The six consecutive address locations must be in the order listed.  $\overline{WE}$  must be HIGH during all six cycles to enable a nonvolatile cycle.
5. While there are 19 address lines on the CY14B104L/CY14B104N, only the lower 16 lines are used to control software modes.
6. IO state depends on the state of  $\overline{OE}$ . The IO table shown assumes  $\overline{OE}$  LOW.

**Table 1. Mode Selection** (continued)

$\overline{CE}$	$\overline{WE}$	$\overline{OE}$	A15 - A0	Mode	IO	Power
L	H	L	0x4E38 0xB1C7 0x83E0 0x7C1F 0x703F 0x8FC0	Read SRAM Read SRAM Read SRAM Read SRAM Read SRAM Nonvolatile Store	Output Data Output Data Output Data Output Data Output Data Output High Z	Active $I_{CC2}$ <sup>[4,5,6]</sup>
L	H	L	0x4E38 0xB1C7 0x83E0 0x7C1F 0x703F 0x4C63	Read SRAM Read SRAM Read SRAM Read SRAM Read SRAM Nonvolatile Recall	Output Data Output Data Output Data Output Data Output Data Output High Z	Active <sup>[4,5,6]</sup>

### Preventing AutoStore

The AutoStore function is disabled by initiating an AutoStore disable sequence. A sequence of read operations is performed in a manner similar to the software STORE initiation. To initiate the AutoStore disable sequence, the following sequence of CE controlled read operations must be performed:

1. Read address 0x4E38 Valid READ
2. Read address 0xB1C7 Valid READ
3. Read address 0x83E0 Valid READ
4. Read address 0x7C1F Valid READ
5. Read address 0x703F Valid READ
6. Read address 0x8B45 AutoStore Disable

The AutoStore is re-enabled by initiating an AutoStore enable sequence. A sequence of read operations is performed in a manner similar to the software RECALL initiation. To initiate the AutoStore enable sequence, the following sequence of CE controlled read operations must be performed:

1. Read address 0x4E38 Valid READ
2. Read address 0xB1C7 Valid READ
3. Read address 0x83E0 Valid READ
4. Read address 0x7C1F Valid READ
5. Read address 0x703F Valid READ
6. Read address 0x4B46 AutoStore Enable

If the AutoStore function is disabled or re-enabled a manual STORE operation (hardware or software) must be issued to save the AutoStore state through subsequent power down cycles. The part comes from the factory with AutoStore enabled.

### Data Protection

The CY14B104L/CY14B104N protects data from corruption during low voltage conditions by inhibiting all externally initiated STORE and write operations. The low voltage condition is detected when  $V_{CC} < V_{SWITCH}$ . If the CY14B104L/CY14B104N is in a write mode (both CE and WE LOW) at power up, after a RECALL or STORE, the write is inhibited until a negative transition on CE or WE is detected. This protects against inadvertent writes during power up or brown out conditions.

### Noise Considerations

Refer CY Application Note [AN1064](#).



**PRELIMINARY**

**CY14B104L, CY14B104N**

**Maximum Ratings**

Exceeding maximum ratings may impair the useful life of the device. These user guidelines are not tested.

- Storage Temperature ..... -65°C to +150°C
- Ambient Temperature with Power Applied ..... -55°C to +150°C
- Supply Voltage on V<sub>CC</sub> Relative to GND ..... -0.5V to 4.1V
- Voltage Applied to Outputs in High-Z State ..... -0.5V to V<sub>CC</sub> + 0.5V
- Input Voltage ..... -0.5V to V<sub>CC</sub>+0.5V
- Transient Voltage (<20 ns) on Any Pin to Ground Potential ..... -2.0V to V<sub>CC</sub> + 2.0V

- Package Power Dissipation Capability (T<sub>A</sub> = 25°C) ..... 1.0W
- Surface Mount Pb Soldering Temperature (3 Seconds) ..... +260°C
- Output Short Circuit Current [7] ..... 15 mA
- Static Discharge Voltage..... > 2001V (per MIL-STD-883, Method 3015)
- Latch-up Current..... > 200 mA

**Operating Range**

Range	Ambient Temperature	V <sub>CC</sub>
Commercial	0°C to +70°C	2.7V to 3.6V
Industrial	-40°C to +85°C	2.7V to 3.6V

**DC Electrical Characteristics**

Over the Operating Range (V<sub>CC</sub> = 2.7V to 3.6V)<sup>[8]</sup>

Parameter	Description	Test Conditions	Min	Max	Unit	
I <sub>CC1</sub>	Average V <sub>CC</sub> Current	t <sub>AVAV</sub> = 15 ns t <sub>AVAV</sub> = 25 ns t <sub>AVAV</sub> = 45 ns Dependent on output loading and cycle rate. Values obtained without output loads. I <sub>OUT</sub> = 0 mA	Commercial		70 65 50	mA mA mA
			Industrial		75 70 52	mA mA mA
I <sub>CC2</sub>	Average V <sub>CC</sub> Current during STORE	All Inputs Don't Care, V <sub>CC</sub> = Max Average current for duration t <sub>STORE</sub>		3	mA	
I <sub>CC3</sub>	Average V <sub>CC</sub> Current at t <sub>AVAV</sub> = 200 ns, 3V, 25°C typical	WE > (V <sub>CC</sub> - 0.2). All other I/P cycling. Dependent on output loading and cycle rate. Values obtained without output loads.		13	mA	
I <sub>CC4</sub>	Average V <sub>CAP</sub> Current during AutoStore Cycle	All Inputs Don't Care, V <sub>CC</sub> = Max Average current for duration t <sub>STORE</sub>		3	mA	
I <sub>SB</sub>	V <sub>CC</sub> Standby Current	CE > (V <sub>CC</sub> - 0.2). All others V <sub>IN</sub> < 0.2V or > (V <sub>CC</sub> - 0.2V). Standby current level after nonvolatile cycle is complete. Inputs are static. f = 0 MHz.		2	mA	
I <sub>IX</sub>	Input Leakage Current	V <sub>CC</sub> = Max, V <sub>SS</sub> ≤ V <sub>IN</sub> ≤ V <sub>CC</sub>	-1	+1	μA	
I <sub>OZ</sub>	Off-State Output Leakage Current	V <sub>CC</sub> = Max, V <sub>SS</sub> ≤ V <sub>IN</sub> ≤ V <sub>CC</sub> , CE or OE > V <sub>IH</sub>	-1	+1	μA	
V <sub>IH</sub>	Input HIGH Voltage		2.0	V <sub>CC</sub> + 0.5	V	
V <sub>IL</sub>	Input LOW Voltage		V <sub>SS</sub> - 0.5	0.8	V	
V <sub>OH</sub>	Output HIGH Voltage	I <sub>OUT</sub> = -2 mA	2.4		V	
V <sub>OL</sub>	Output LOW Voltage	I <sub>OUT</sub> = 4 mA		0.4	V	
V <sub>CAP</sub>	Storage Capacitor	Between V <sub>CAP</sub> pin and V <sub>SS</sub> , 5V Rated	35	57	μF	

**Capacitance**

In the following table, the capacitance parameters are listed.<sup>[9]</sup>

Parameter	Description	Test Conditions	Max	Unit
C <sub>IN</sub>	Input Capacitance	T <sub>A</sub> = 25°C, f = 1 MHz, V <sub>CC</sub> = 0 to 3.0V	7	pF
C <sub>OUT</sub>	Output Capacitance		7	pF

**Notes**

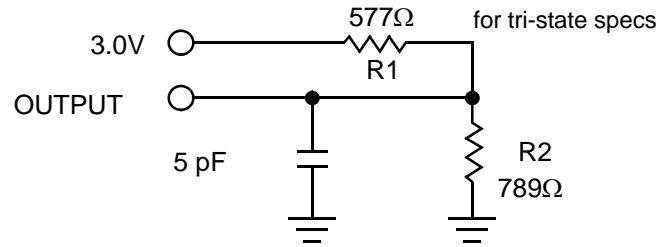
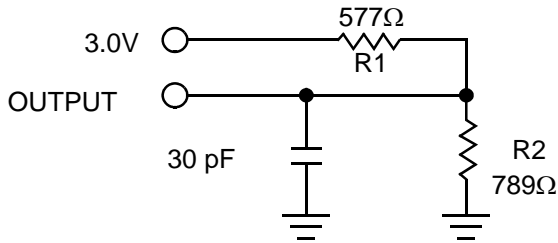
- 7. Outputs shorted for no more than one second. No more than one output shorted at a time.
- 8. Typical conditions for the active current shown on the front page of the data sheet are average values at 25°C (room temperature), and V<sub>CC</sub> = 3V. Not 100% tested.
- 9. These parameters are guaranteed but not tested.

### Thermal Resistance

In the following table, the thermal resistance parameters are listed. <sup>[9]</sup>

Parameter	Description	Test Conditions	48-FBGA	44-TSOP II	54-TSOP II	Unit
$\Theta_{JA}$	Thermal Resistance (Junction to Ambient)	Test conditions follow standard test methods and procedures for measuring thermal impedance, in accordance with EIA/JESD51.	TBD	TBD	TBD	°C/W
$\Theta_{JC}$	Thermal Resistance (Junction to Case)		TBD	TBD	TBD	°C/W

### AC Test Loads





**AC Test Conditions**

Input Pulse Levels .....0V to 3V  
 Input Rise and Fall Times (10% - 90%) ..... <5 ns  
 Input and Output Timing Reference Levels ..... 1.5V

**AC Switching Characteristics**

In the following table, the AC switching characteristics are listed.

Parameters		Description	15 ns		25 ns		45 ns		Unit
Cypress Parameters	Alt Parameters		Min	Max	Min	Max	Min	Max	
<b>SRAM Read Cycle</b>									
t <sub>ACE</sub>	t <sub>ACS</sub>	Chip Enable Access Time		15		25		45	ns
t <sub>RC</sub> <sup>[10]</sup>	t <sub>RC</sub>	Read Cycle Time	15		25		45		ns
t <sub>AA</sub> <sup>[11]</sup>	t <sub>AA</sub>	Address Access Time		15		25		45	ns
t <sub>DOE</sub>	t <sub>OE</sub>	Output Enable to Data Valid		10		12		20	ns
t <sub>OHA</sub>	t <sub>OH</sub>	Output Hold After Address Change	3		3		3		ns
t <sub>LZCE</sub> <sup>[12]</sup>	t <sub>LZ</sub>	Chip Enable to Output Active	3		3		3		ns
t <sub>HZCE</sub> <sup>[12]</sup>	t <sub>HZ</sub>	Chip Disable to Output Inactive		7		10		15	ns
t <sub>LZOE</sub> <sup>[12]</sup>	t <sub>OLZ</sub>	Output Enable to Output Active	0		0		0		ns
t <sub>HZOE</sub> <sup>[12]</sup>	t <sub>OHZ</sub>	Output Disable to Output Inactive		7		10		15	ns
t <sub>PU</sub> <sup>[9]</sup>	t <sub>PA</sub>	Chip Enable to Power Active	0		0		0		ns
t <sub>PD</sub> <sup>[9]</sup>	t <sub>PS</sub>	Chip Disable to Power Standby		15		25		45	ns
t <sub>DBE</sub>	-	Byte Enable to Data Valid		10		12		22	ns
t <sub>LZBE</sub>	-	Byte Enable to Output Active	0		0		0		ns
t <sub>HZBE</sub>	-	Byte Disable to Output Inactive		7		10		22	ns
<b>SRAM Write Cycle</b>									
t <sub>WC</sub>	t <sub>WC</sub>	Write Cycle Time	15		25		45		ns
t <sub>PWE</sub>	t <sub>WP</sub>	Write Pulse Width	10		20		30		ns
t <sub>SCE</sub>	t <sub>CW</sub>	Chip Enable To End of Write	15		20		30		ns
t <sub>SD</sub>	t <sub>DW</sub>	Data Setup to End of Write	5		10		15		ns
t <sub>HD</sub>	t <sub>DH</sub>	Data Hold After End of Write	0		0		0		ns
t <sub>AW</sub>	t <sub>AW</sub>	Address Setup to End of Write	15		20		30		ns
t <sub>SA</sub>	t <sub>AS</sub>	Address Setup to Start of Write	0		0		0		ns
t <sub>HA</sub>	t <sub>WR</sub>	Address Hold After End of Write	0		0		0		ns
t <sub>HZWE</sub> <sup>[12,13]</sup>	t <sub>WZ</sub>	Write Enable to Output Disable		7		10		15	ns
t <sub>LZWE</sub> <sup>[12]</sup>	t <sub>OW</sub>	Output Active after End of Write	3		3		3		ns
t <sub>BW</sub>	-	Byte Enable to End of Write	15		20		30		ns

**Notes**

- 10. WE must be HIGH during SRAM read cycles.
- 11. Device is continuously selected with CE and OE both LOW.
- 12. Measured ±200 mV from steady state output voltage.
- 13. If CE is LOW and then WE goes LOW, the output goes into high impedance state after t<sub>HZWE</sub> time period.

**AutoStore/Power Up RECALL**

Parameters	Description	CY14B104L/CY14B104N		Unit
		Min	Max	
$t_{HRECALL}^{[14]}$	Power Up RECALL Duration		20	ms
$t_{STORE}^{[15]}$	STORE Cycle Duration		15	ms
$V_{SWITCH}$	Low Voltage Trigger Level		2.65	V
$t_{VCCRISE}$	VCC Rise Time	150		$\mu$ s

**Software Controlled STORE/RECALL Cycle**

In the following table, the software controlled STORE/RECALL cycle parameters are listed.<sup>[16, 17]</sup>

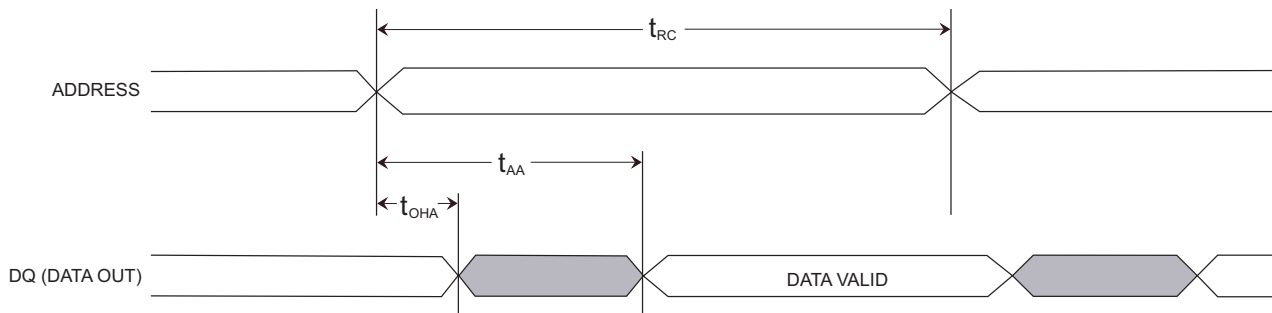
Parameters	Description	15ns		25ns		45ns		Unit
		Min	Max	Min	Max	Min	Max	
$t_{RC}$	STORE/RECALL Initiation Cycle Time	15		25		45		ns
$t_{AS}$	Address Setup Time	0		0		0		ns
$t_{CW}$	Clock Pulse Width	12		20		30		ns
$t_{GHAX}$	Address Hold Time	1		1		1		ns
$t_{RECALL}$	RECALL Duration		100		100		100	$\mu$ s
$t_{SS}^{[18, 19]}$	Soft Sequence Processing Time		70		70		70	$\mu$ s

**Hardware STORE Cycle**

Parameters	Description	CY14B104L/CY14B104N		Unit
		Min	Max	
$t_{DELAY}^{[20]}$	Time allowed to complete SRAM Cycle	1	70	$\mu$ s
$t_{HLHX}$	Hardware STORE Pulse Width	15		ns

**Switching Waveforms**

**Figure 5. SRAM Read Cycle #1: Address Controlled<sup>[10, 11, 21]</sup>**

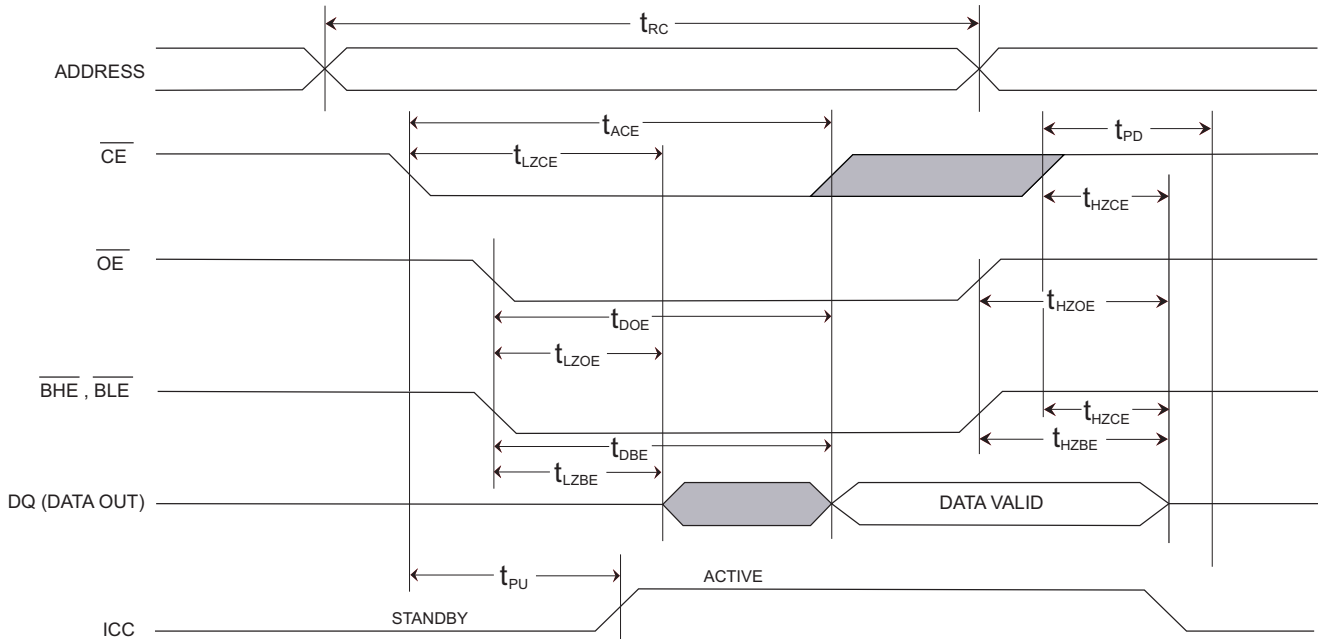


**Notes**

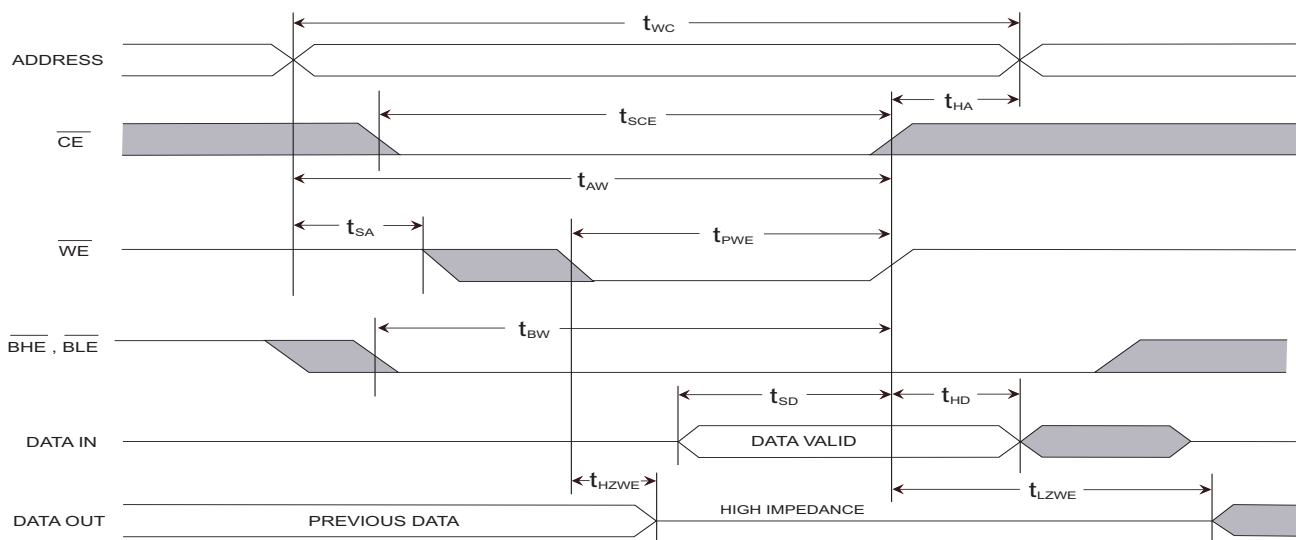
- 14.  $t_{HRECALL}$  starts from the time  $V_{CC}$  rises above  $V_{SWITCH}$ .
- 15. If an SRAM Write has not taken place since the last nonvolatile cycle, no STORE takes place.
- 16. The software sequence is clocked with  $\overline{CE}$  controlled or  $\overline{OE}$  controlled reads.
- 17. The six consecutive addresses must be read in the order listed in the mode selection table.  $\overline{WE}$  must be HIGH during all six consecutive cycles.
- 18. This is the amount of time it takes to take action on a soft sequence command.  $V_{CC}$  power must remain HIGH to effectively register command.
- 19. Commands such as STORE and RECALL lock out IO until operation is complete which further increases this time. See the specific command
- 20. Read and write cycles are in progress before  $\overline{HSB}$  are supplied this amount of time to complete.
- 21.  $\overline{HSB}$  must remain HIGH during READ and WRITE cycles.

**Switching Waveforms** (continued)

**Figure 6. SRAM Read Cycle #2:  $\overline{CE}$  and  $\overline{OE}$  Controlled**<sup>[10, 21, 23]</sup>



**Figure 7. SRAM Write Cycle #1:  $\overline{WE}$  Controlled**<sup>[21, 22, 23]</sup>

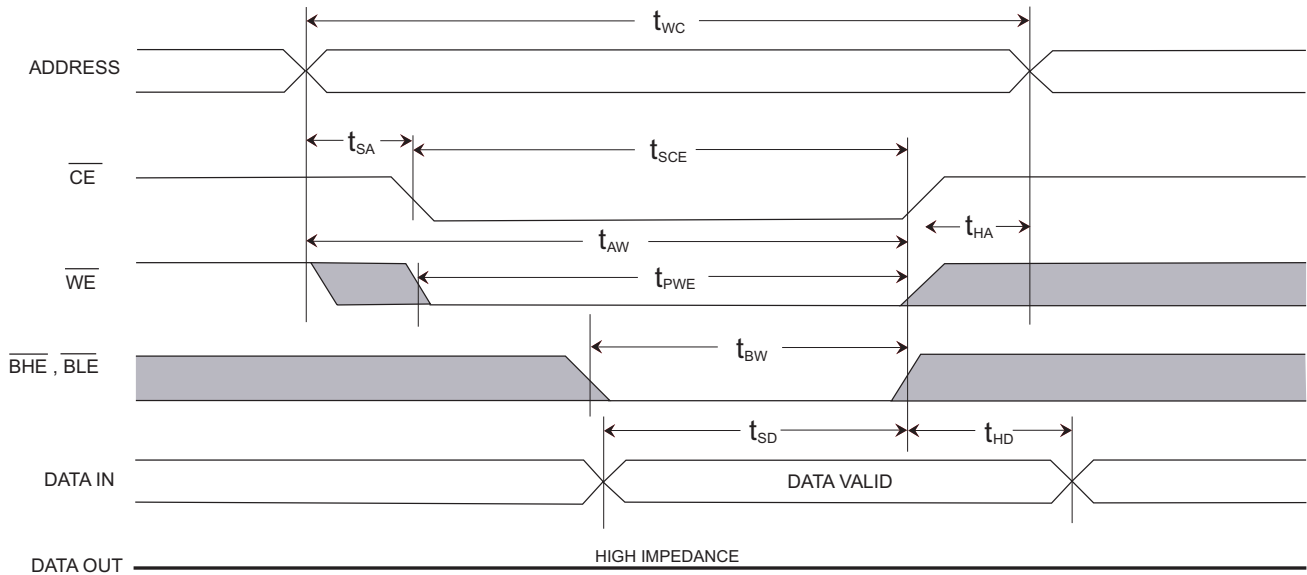


**Notes**

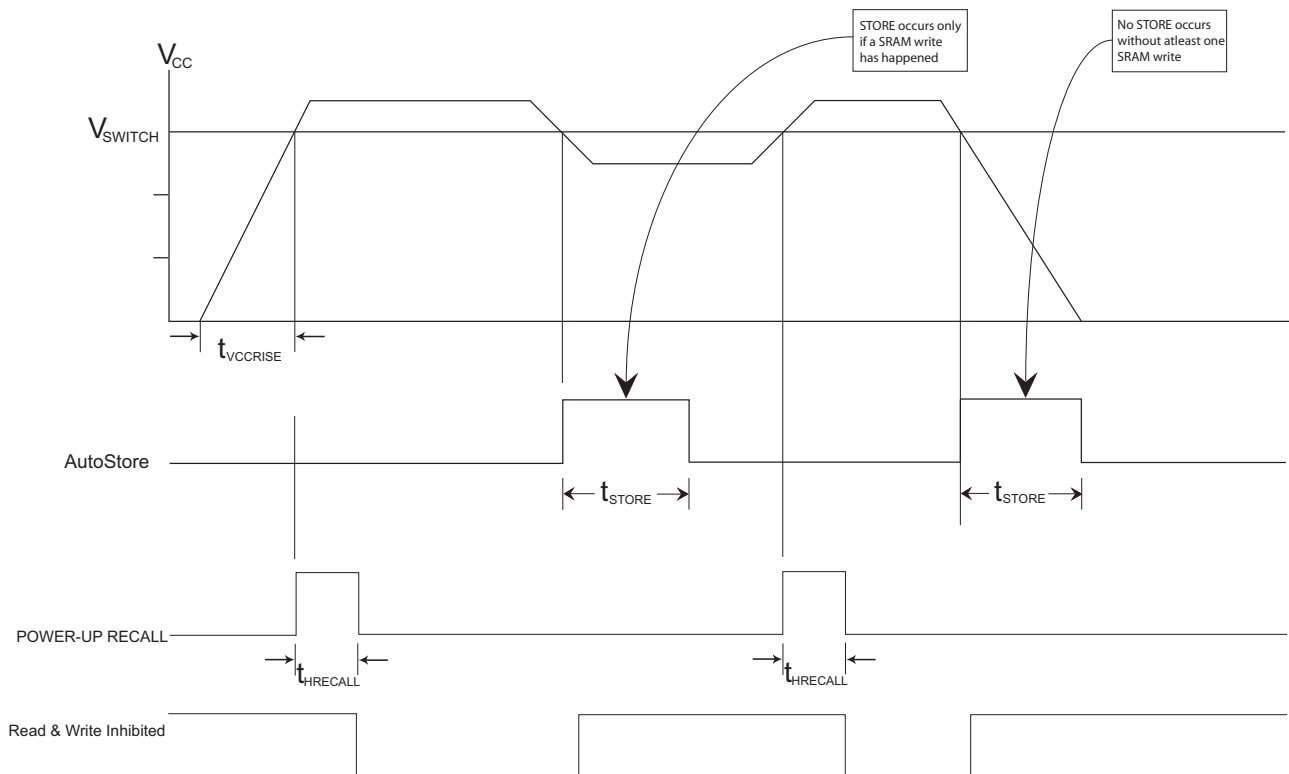
- 22.  $\overline{CE}$  or  $\overline{WE}$  must be  $\geq V_{IH}$  during address transitions.
- 23. BHE and BLE are applicable for x16 configuration only.

**Switching Waveforms** (continued)

**Figure 8. SRAM Write Cycle #2:  $\overline{\text{CE}}$  Controlled<sup>[23]</sup>**

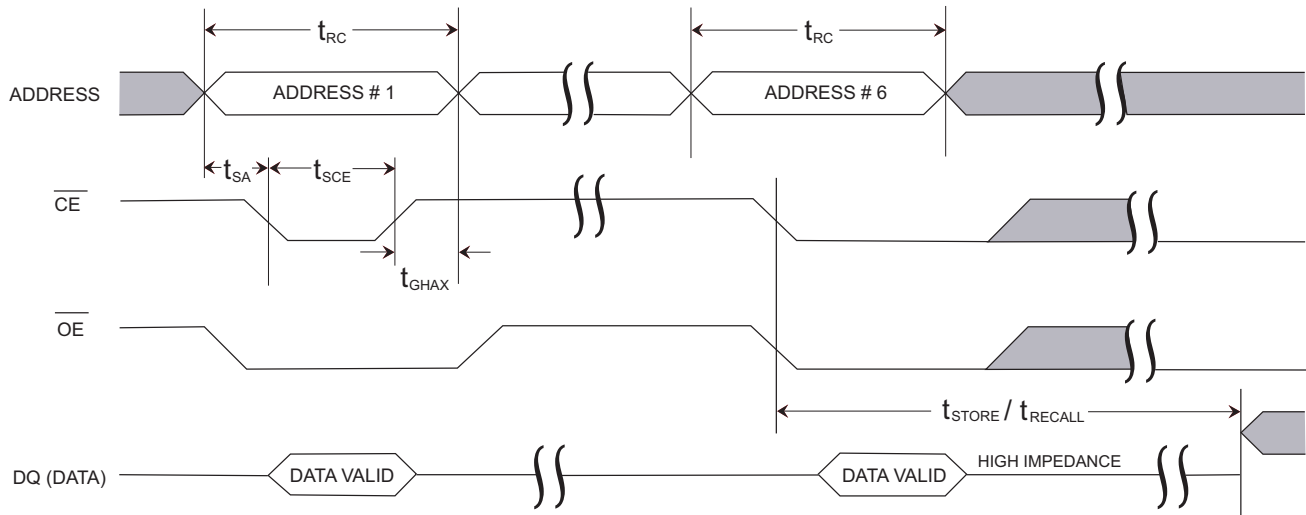


**Figure 9. AutoStore or Power Up RECALL**

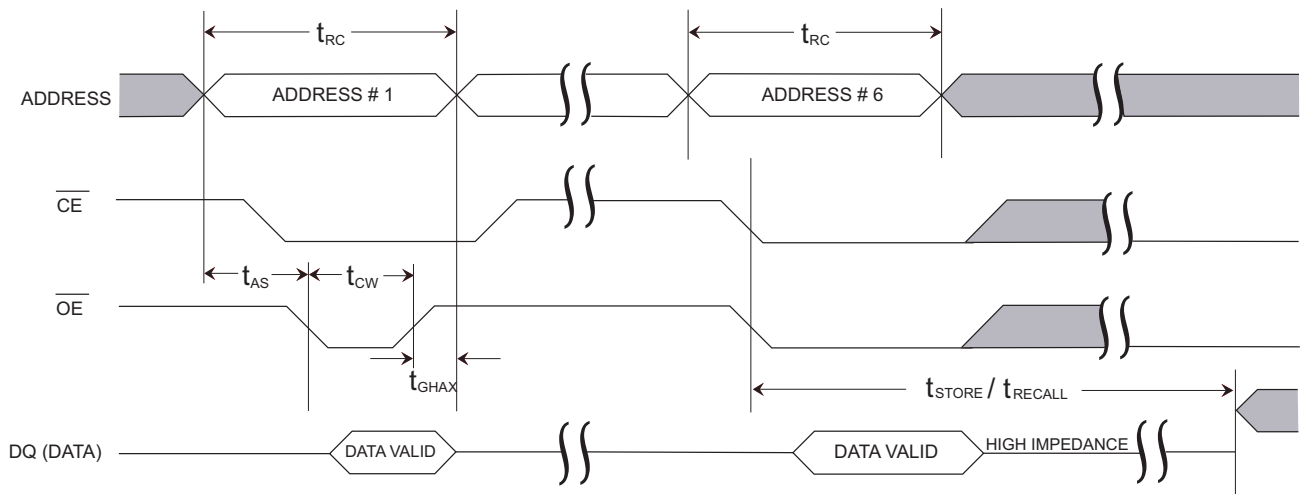


**Switching Waveforms** (continued)

**Figure 10.  $\overline{\text{CE}}$ -controlled Software STORE/RECALL Cycle<sup>[17]</sup>**

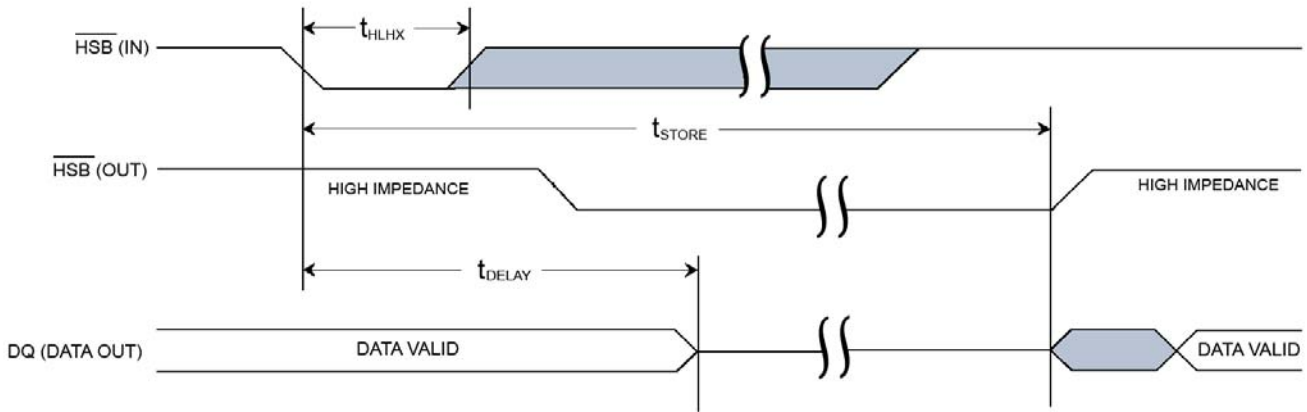


**Figure 11.  $\overline{\text{OE}}$ -controlled Software STORE/RECALL Cycle<sup>[17]</sup>**

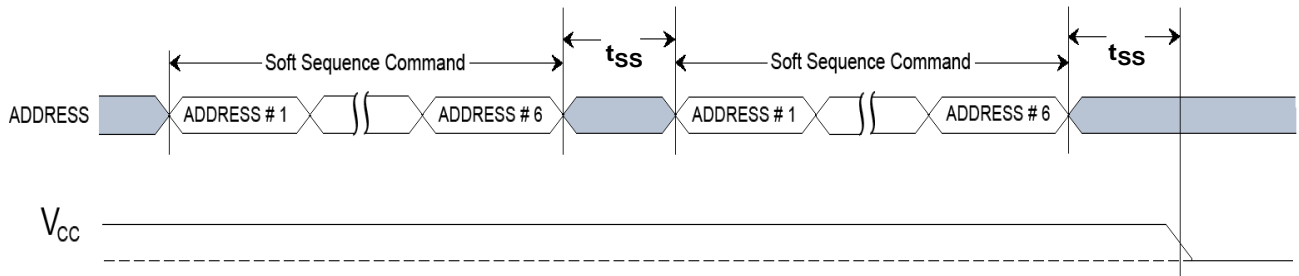


**Switching Waveforms** (continued)

**Figure 12. Hardware STORE Cycle<sup>[20]</sup>**



**Figure 13. Soft Sequence Processing<sup>[18, 19]</sup>**





**PRELIMINARY**

**CY14B104L, CY14B104N**

**Ordering Information**

Speed (ns)	Ordering Code	Package Diagram	Package Type	Operating Range
15	CY14B104L-ZS15XCT	51-85087	44-pin TSOP II	Commercial
	CY14B104L-ZS15XIT	51-85087	44-pin TSOP II	Industrial
	CY14B104L-ZS15XI	51-85087	44-pin TSOP II	
	CY14B104L-BA15XCT	51-85128	48-ball FBGA	Commercial
	CY14B104L-BA15XIT	51-85128	48-ball FBGA	Industrial
	CY14B104L-BA15XI	51-85128	48-ball FBGA	
	CY14B104L-ZSP15XCT	51-85160	54-pin TSOP II	Commercial
	CY14B104L-ZSP15XIT	51-85160	54-pin TSOP II	Industrial
	CY14B104L-ZSP15XI	51-85160	54-pin TSOP II	
	CY14B104N-ZS15XCT	51-85087	44-pin TSOP II	Commercial
	CY14B104N-ZS15XIT	51-85087	44-pin TSOP II	Industrial
	CY14B104N-ZS15XI	51-85087	44-pin TSOP II	
	CY14B104N-BA15XCT	51-85128	48-ball FBGA	Commercial
	CY14B104N-BA15XIT	51-85128	48-ball FBGA	Industrial
	CY14B104N-BA15XI	51-85128	48-ball FBGA	
	CY14B104N-ZSP15XCT	51-85160	54-pin TSOP II	Commercial
	CY14B104N-ZSP15XIT	51-85160	54-pin TSOP II	Industrial
	CY14B104N-ZSP15XI	51-85160	54-pin TSOP II	
25	CY14B104L-ZS25XCT	51-85087	44-pin TSOP II	Commercial
	CY14B104L-ZS25XIT	51-85087	44-pin TSOP II	Industrial
	CY14B104L-ZS25XI	51-85087	44-pin TSOP II	
	CY14B104L-BA25XIT	51-85128	48-ball FBGA	Industrial
	CY14B104L-BA25XI	51-85128	48-ball FBGA	
	CY14B104N-BA25XCT	51-85128	48-ball FBGA	Commercial
	CY14B104L-ZSP25XCT	51-85160	54-pin TSOP II	Commercial
	CY14B104L-ZSP25XIT	51-85160	54-pin TSOP II	Industrial
	CY14B104L-ZSP25XI	51-85160	54-pin TSOP II	
	CY14B104N-ZS25XCT	51-85087	44-pin TSOP II	Commercial
	CY14B104N-ZS25XIT	51-85087	44-pin TSOP II	Industrial
	CY14B104N-ZS25XI	51-85087	44-pin TSOP II	
	CY14B104N-BA25XCT	51-85128	48-ball FBGA	Commercial
	CY14B104N-BA25XIT	51-85128	48-ball FBGA	Industrial
	CY14B104N-BA25XI	51-85128	48-ball FBGA	
	CY14B104N-ZSP25XCT	51-85160	54-pin TSOP II	Commercial
	CY14B104N-ZSP25XIT	51-85160	54-pin TSOP II	Industrial
	CY14B104N-ZSP25XI	51-85160	54-pin TSOP II	



**PRELIMINARY**

**CY14B104L, CY14B104N**

**Ordering Information** (continued)

Speed (ns)	Ordering Code	Package Diagram	Package Type	Operating Range
45	CY14B104L-ZS45XCT	51-85087	44-pin TSOP II	Commercial
	CY14B104L-ZS45XIT	51-85087	44-pin TSOP II	Industrial
	CY14B104L-ZS45XI	51-85087	44-pin TSOP II	
	CY14B104L-BA45XCT	51-85128	48-ball FBGA	Commercial
	CY14B104L-BA45XIT	51-85128	48-ball FBGA	Industrial
	CY14B104L-BA45XI	51-85128	48-ball FBGA	
	CY14B104L-ZSP45XCT	51-85160	54-pin TSOP II	Commercial
	CY14B104L-ZSP45XIT	51-85160	54-pin TSOP II	Industrial
	CY14B104L-ZSP45XI	51-85160	54-pin TSOP II	
	CY14B104N-ZS45XCT	51-85087	44-pin TSOP II	Commercial
	CY14B104N-ZS45XIT	51-85087	44-pin TSOP II	Industrial
	CY14B104N-ZS45XI	51-85087	44-pin TSOP II	
	CY14B104N-BA45XCT	51-85128	48-ball FBGA	Commercial
	CY14B104N-BA45XIT	51-85128	48-ball FBGA	Industrial
	CY14B104N-BA45XI	51-85128	48-ball FBGA	
	CY14B104N-ZSP45XCT	51-85160	54-pin TSOP II	Commercial
	CY14B104N-ZSP45XIT	51-85160	54-pin TSOP II	Industrial
	CY14B104N-ZSP45XI	51-85160	54-pin TSOP II	

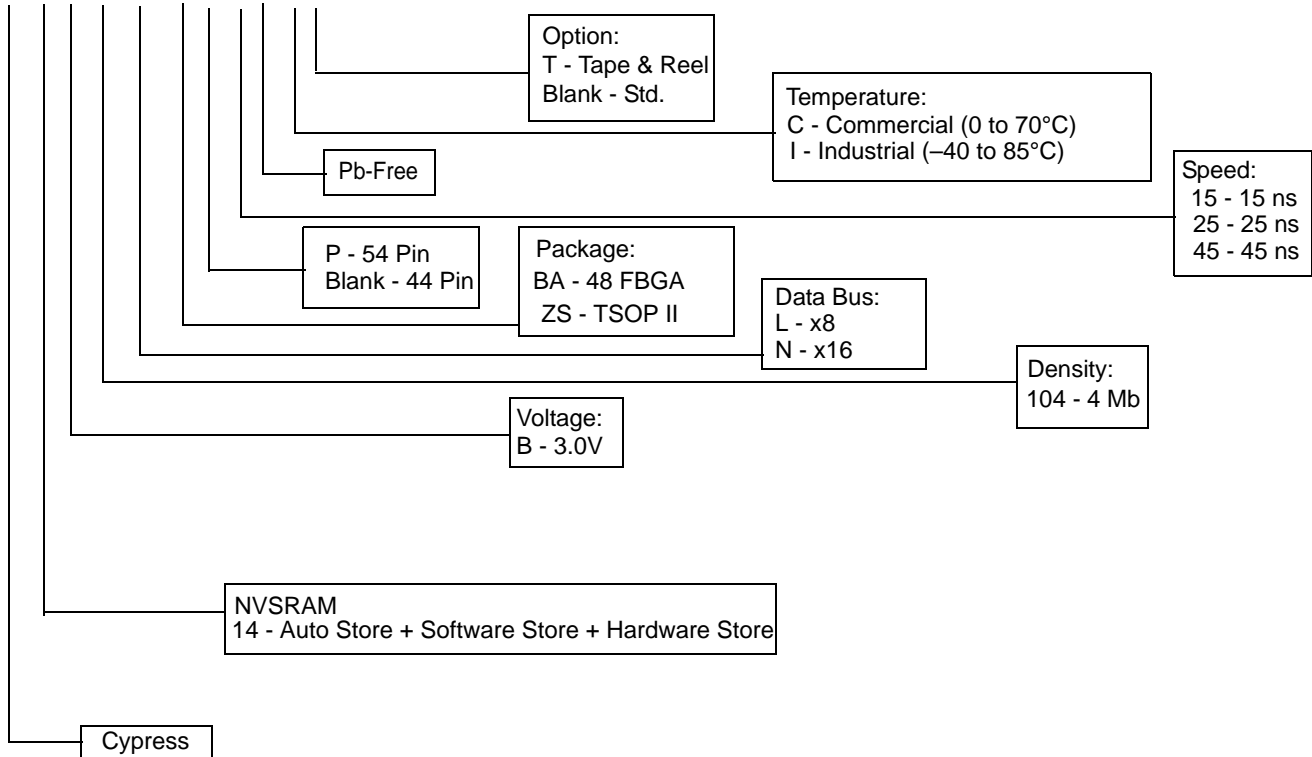


**PRELIMINARY**

**CY14B104L, CY14B104N**

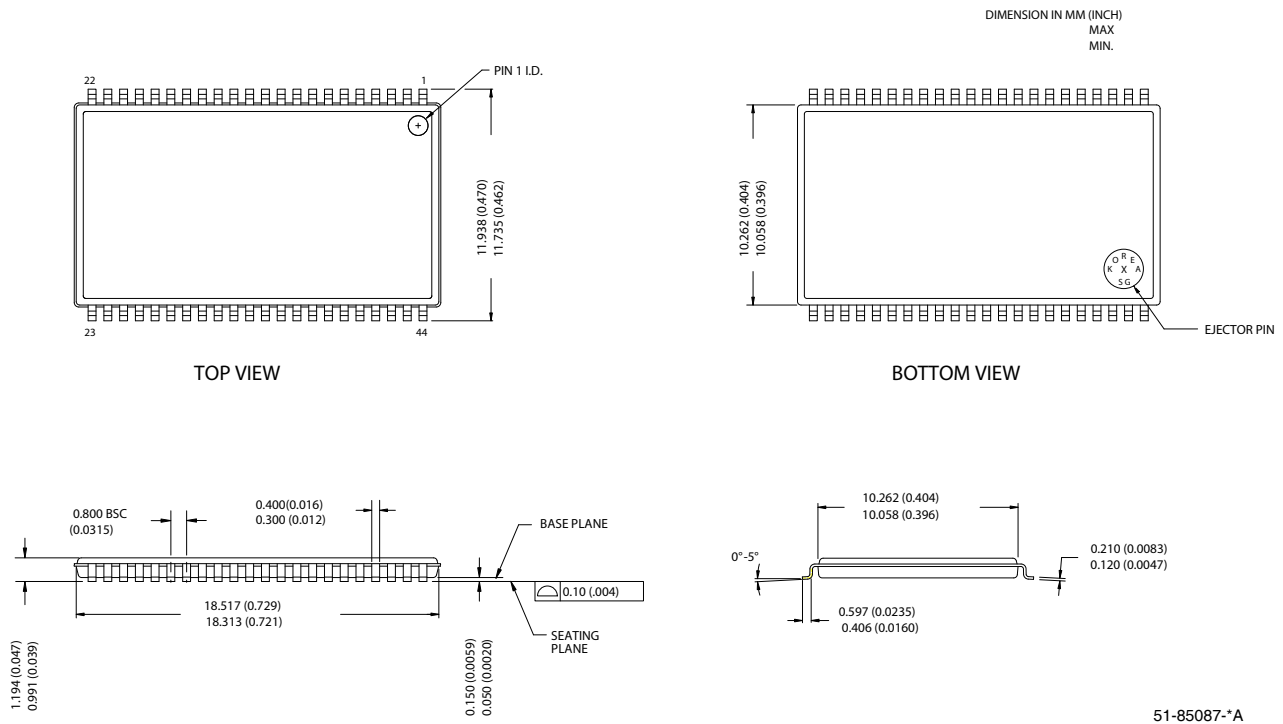
### Part Numbering Nomenclature

**CY 14 B 104 L - ZS P 15 X C T**



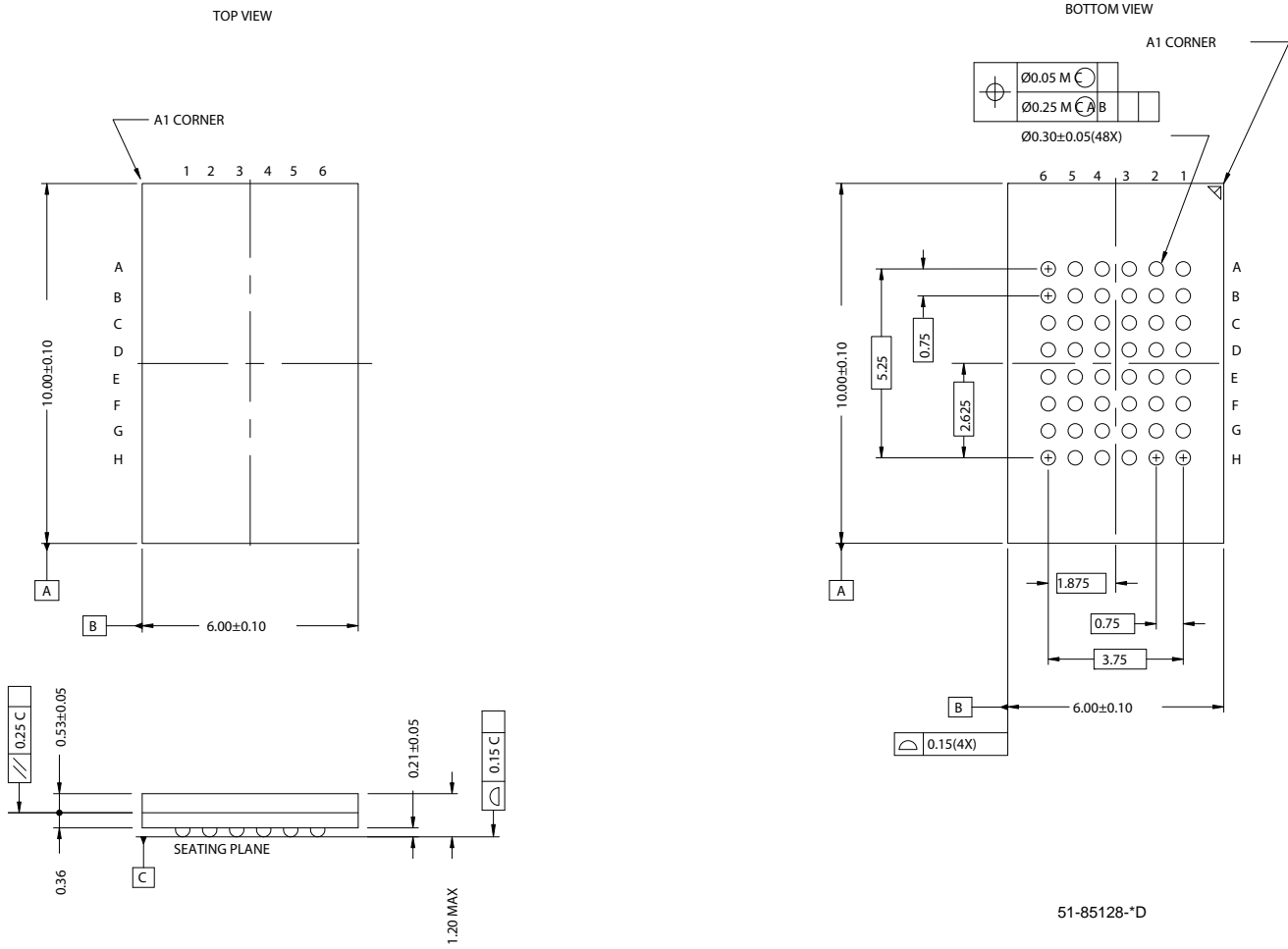
**Package Diagrams**

**Figure 14. 44-Pin TSOP II (51-85087)**



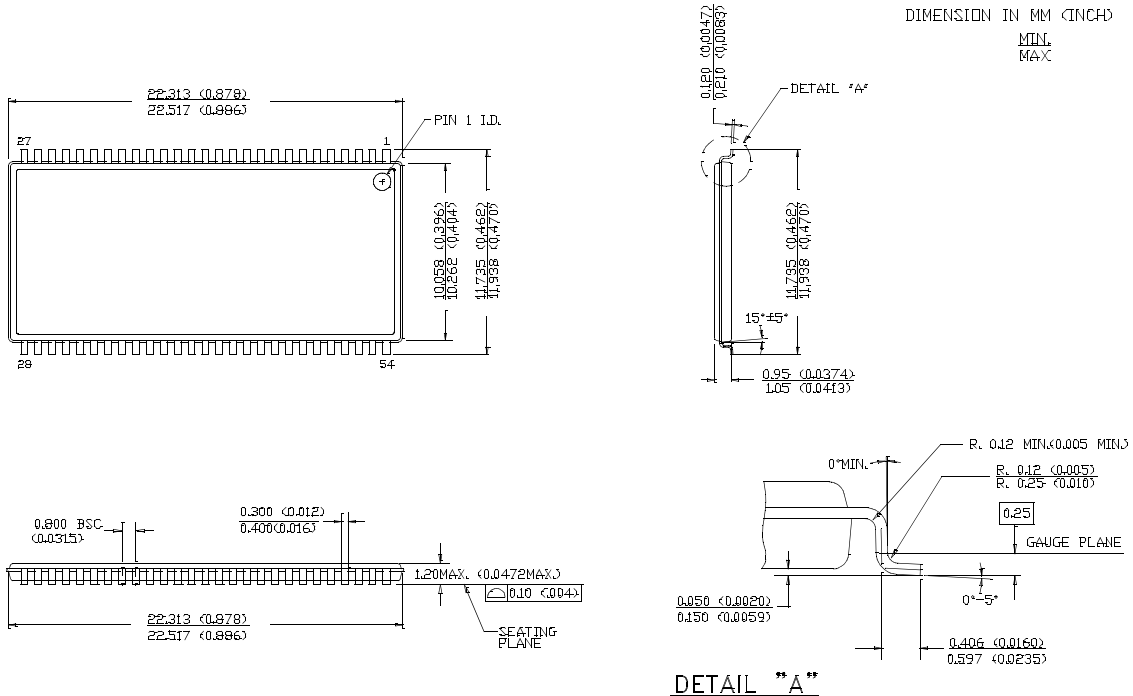
**Package Diagrams** (continued)

**Figure 15. 48-ball FBGA (6 mm x 10 mm x 1.2 mm)**



**Package Diagrams** (continued)

**Figure 16. 54-Pin TSOP II (51-85160)**



51-85160-\*\*



**PRELIMINARY**

**CY14B104L, CY14B104N**

**Document History Page**

Document Title: CY14B104L/CY14B104N 4-Mbit (512K x 8/256K x 16) nvSRAM Document Number: 001-07102				
REV.	ECN NO.	Issue Date	Orig. of Change	Description of Change
**	431039	See ECN	TUP	New Data Sheet
*A	489096	See ECN	TUP	Removed 48 SSOP Package Added 48 FBGA and 54 TSOPII Packages Updated Part Numbering Nomenclature and Ordering Information Added Soft Sequence Processing Time Waveform
*B	499597	See ECN	PCI	Removed 35 ns speed bin Added 55 ns speed bin. Updated AC table for the same Changed "Unlimited" read/write to "infinite" read/write Features section: Changed typical I <sub>CC</sub> at 200-ns cycle time to 8 mA Changed STORE cycles from 500K to 200K cycles Shaded Commercial grade in operating range table Modified I <sub>CC</sub> /I <sub>SB</sub> specs 48 FBGA package nomenclature changed from BW to BV Modified part nomenclature table. Changes reflected in the ordering information table
*C	517793	See ECN	TUP	Removed 55ns speed bin Changed pinout for 44TSOPII and 54TSOPII packages Changed I <sub>SB</sub> to 1mA Changed I <sub>CC4</sub> to 3mA Changed V <sub>CAP</sub> min to 35μF Changed V <sub>IH</sub> max to V <sub>CC</sub> + 0.5V Changed t <sub>STORE</sub> to 15ms Changed t <sub>PWE</sub> to 10ns Changed t <sub>SCE</sub> to 15ns Changed t <sub>SD</sub> to 5ns Changed t <sub>AW</sub> to 10ns Removed t <sub>HLBL</sub> Added Timing Parameters for $\overline{BHE}$ and $\overline{BLE}$ - t <sub>DBE</sub> , t <sub>LZBE</sub> , t <sub>HZBE</sub> , t <sub>BW</sub> Removed min specification for Vswitch Changed t <sub>GLAX</sub> to 1ns Added t <sub>DELAY</sub> max of 70us Changed t <sub>SS</sub> specification from 70us min to 70us max
*D	774001	See ECN	UHA	Changed the data sheet from Advance information to Preliminary 48 FBGA package code changed from BV to BA Removed 48 FBGA package in X8 configuration in ordering information. Changed t <sub>DBE</sub> to 10ns in 15ns part Changed t <sub>HZBE</sub> in 15ns part to 7ns and in 25ns part to 10ns Changed t <sub>BW</sub> in 15ns part to 15ns and in 25ns part to 20ns Changed t <sub>GLAX</sub> to t <sub>GHAX</sub> Changed the value of I <sub>CC3</sub> to 25mA Changed the value of t <sub>AW</sub> in 15ns part to 15ns Changed A <sub>18</sub> and A <sub>19</sub> Pins in FBGA Pin Configuration to NC



**PRELIMINARY**

**CY14B104L, CY14B104N**

Document Title: CY14B104L/CY14B104N 4-Mbit (512K x 8/256K x 16) nvSRAM				
Document Number: 001-07102				
REV.	ECN NO.	Issue Date	Orig. of Change	Description of Change
*E	914220	See ECN	UHA	Included all the information for 45 ns part in this data sheet
*F	1889928	See ECN	vsutmp8/AESA	Added Footnotes 1, 2 and 3. Updated logic block diagram Added 48-FBGA (X8) Pin Diagram Changed 8Mb Address expansion Pin from Pin 43 to Pin 42 for 44-TSOP II (x8) package. Updated pin definitions table. Corrected typo in $V_{IL}$ min spec Changed the value of $I_{CC3}$ from 25mA to 13mA Changed $I_{SB}$ value from 1mA to 2mA Rearranging of Footnotes. Updated ordering information table

© Cypress Semiconductor Corporation, 2006-2008. The information contained herein is subject to change without notice. Cypress Semiconductor Corporation assumes no responsibility for the use of any circuitry other than circuitry embodied in a Cypress product. Nor does it convey or imply any license under patent or other rights. Cypress products are not warranted nor intended to be used for medical, life support, life saving, critical control or safety applications, unless pursuant to an express written agreement with Cypress. Furthermore, Cypress does not authorize its products for use as critical components in life-support systems where a malfunction or failure may reasonably be expected to result in significant injury to the user. The inclusion of Cypress products in life-support systems application implies that the manufacturer assumes all risk of such use and in doing so indemnifies Cypress against all charges.

Any Source Code (software and/or firmware) is owned by Cypress Semiconductor Corporation (Cypress) and is protected by and subject to worldwide patent protection (United States and foreign), United States copyright laws and international treaty provisions. Cypress hereby grants to licensee a personal, non-exclusive, non-transferable license to copy, use, modify, create derivative works of, and compile the Cypress Source Code and derivative works for the sole purpose of creating custom software and or firmware in support of licensee product to be used only in conjunction with a Cypress integrated circuit as specified in the applicable agreement. Any reproduction, modification, translation, compilation, or representation of this Source Code except as specified above is prohibited without the express written permission of Cypress.

Disclaimer: CYPRESS MAKES NO WARRANTY OF ANY KIND, EXPRESS OR IMPLIED, WITH REGARD TO THIS MATERIAL, INCLUDING, BUT NOT LIMITED TO, THE IMPLIED WARRANTIES OF MERCHANTABILITY AND FITNESS FOR A PARTICULAR PURPOSE. Cypress reserves the right to make changes without further notice to the materials described herein. Cypress does not assume any liability arising out of the application or use of any product or circuit described herein. Cypress does not authorize its products for use as critical components in life-support systems where a malfunction or failure may reasonably be expected to result in significant injury to the user. The inclusion of Cypress' product in a life-support systems application implies that the manufacturer assumes all risk of such use and in doing so indemnifies Cypress against all charges.

Use may be limited by and subject to the applicable Cypress software license agreement.