



CY7C1021BNV33

64K x 16 Static RAM

Features

- 3.3V operation (3.0V–3.6V)
- High speed
 - $t_{AA} = 10, 12, 15$ ns
- CMOS for optimum speed/power
- Low Active Power (L version)
 - 576 mW (max.)
- Low CMOS Standby Power (L version)
 - 1.80 mW (max.)
- Automatic power-down when deselected
- Independent control of upper and lower bits
- Available in 44-pin TSOP II and 400-mil SOJ
- Available in a 48-Ball Mini BGA package

Functional Description^[1]

The CY7C1021BNV is a high-performance CMOS static RAM organized as 65,536 words by 16 bits. This device has an automatic power-down feature that significantly reduces power consumption when deselected.

Writing to the device is accomplished by taking Chip Enable (\overline{CE}) and Write Enable (\overline{WE}) inputs LOW. If Byte Low Enable (\overline{BLE}) is LOW, then data from I/O pins (I/O_1 through I/O_8), is written into the location specified on the address pins (A_0 through A_{15}). If Byte High Enable (\overline{BHE}) is LOW, then data from I/O pins (I/O_9 through I/O_{16}) is written into the location specified on the address pins (A_0 through A_{15}).

Reading from the device is accomplished by taking Chip Enable (\overline{CE}) and Output Enable (\overline{OE}) LOW while forcing the Write Enable (\overline{WE}) HIGH. If Byte Low Enable (\overline{BLE}) is LOW, then data from the memory location specified by the address pins will appear on I/O_1 to I/O_8 . If Byte High Enable (\overline{BHE}) is LOW, then data from memory will appear on I/O_9 to I/O_{16} . See the truth table at the back of this data sheet for a complete description of read and write modes.

The input/output pins (I/O_1 through I/O_{16}) are placed in a high-impedance state when the device is deselected (\overline{CE} HIGH), the outputs are disabled (\overline{OE} HIGH), the \overline{BHE} and \overline{BLE} are disabled (\overline{BHE} , \overline{BLE} HIGH), or during a write operation (\overline{CE} LOW, and \overline{WE} LOW).

The CY7C1021BNV is available in 400-mil-wide SOJ, standard 44-pin TSOP Type II, and 48-ball mini BGA packages.

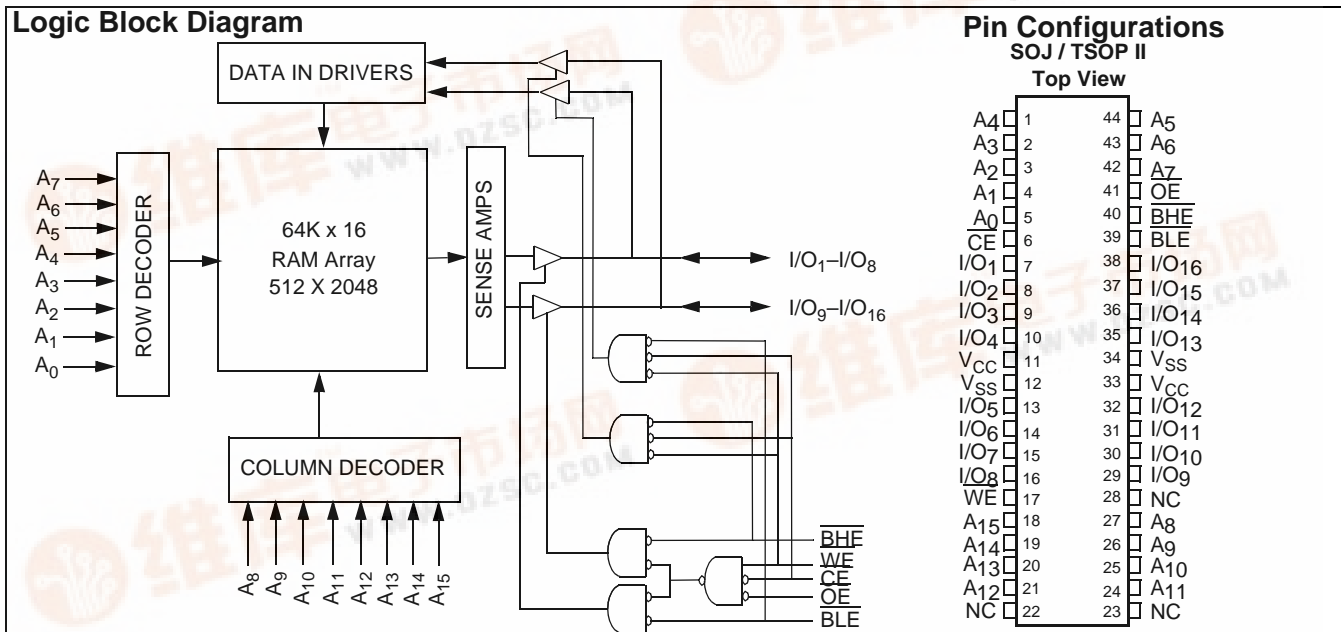

Note:

1. For guidelines on SRAM system design, please refer to the 'System Design Guidelines' Cypress application note, available on the internet at www.cypress.com



Selection Guide

		-10	-12	-15
Maximum Access Time (ns)		10	12	15
Maximum Operating Current (mA)	Commercial	160	150	140
	Industrial	180	170	160
Maximum CMOS Standby Current (mA)	Commercial/Industrial	5	5	5
	L	0.5	0.5	0.5

Pin Configurations

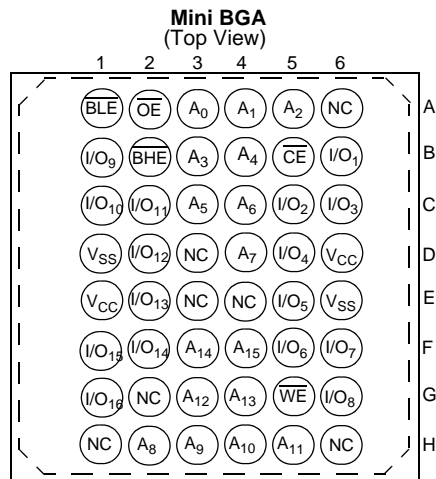

Maximum Ratings

(Above which the useful life may be impaired. For user guidelines, not tested.)

Storage Temperature -65°C to +150°C
 Ambient Temperature with Power Applied..... -55°C to +125°C
 Supply Voltage on V_{CC} to Relative GND^[1] -0.5V to +4.6V
 DC Voltage Applied to Outputs in High Z State^[1] -0.5V to $V_{CC}+0.5V$

DC Input Voltage^[1] -0.5V to $V_{CC}+0.5V$
 Current into Outputs (LOW)..... 20 mA
 Static Discharge Voltage..... >2001V (per MIL-STD-883, Method 3015)
 Latch-Up Current..... >200 mA

Operating Range

Range	Ambient Temperature	V_{CC}
Commercial	0°C to +70°C	3.3V ± 10%
Industrial	-40°C to +85°C	3.3V ± 10%

Electrical Characteristics Over the Operating Range

Parameter	Description	Test Conditions	-10		-12		-15		Unit
			Min.	Max.	Min.	Max.	Min.	Max.	
V_{OH}	Output HIGH Voltage	$V_{CC} = \text{Min.}, I_{OH} = -4.0 \text{ mA}$	2.4		2.4		2.4		V
V_{OL}	Output LOW Voltage	$V_{CC} = \text{Min.}, I_{OL} = 8.0 \text{ mA}$		0.4		0.4		0.4	V
V_{IH}	Input HIGH Voltage		2.2	$V_{CC}+0.3V$	2.2	$V_{CC}+0.3V$	2.2	$V_{CC}+0.3V$	V
V_{IL}	Input LOW Voltage ^[1]		-0.3	0.8	-0.3	0.8	-0.3	0.8	V
I_{IX}	Input Load Current	$GND \leq V_I \leq V_{CC}$	-1	+1	-1	+1	-1	+1	μA
I_{OZ}	Output Leakage Current	$GND \leq V_I \leq V_{CC}$, Output Disabled	-1	+1	-1	+1	-1	+1	μA
I_{CC}	V_{CC} Operating Supply Current	$V_{CC} = \text{Max.}, I_{OUT}=0\text{mA}$ $f = f_{MAX} = 1/t_{RC}$	Com'l	160		150		140	mA
			Ind'l	120		170		160	mA
I_{SB1}	Automatic CE Powerdown Current —TTL Inputs	Max. V_{CC} , $CE \geq V_{IH}$, $V_{IN} \geq V_{IH}$ or $V_{IN} \leq V_{IL}$, $f = f_{MAX}$		40		40		40	mA
I_{SB2}	Automatic CE Power Down Current —CMOS Inputs	Max. V_{CC} , $CE \geq V_{CC}-0.3V$, $V_{IN} \geq V_{CC}-0.3V$ or $V_{IN} \leq 0.3V$, $f = 0$		5		5		5	mA
			L	500		500		500	μA

Capacitance^[2]

Parameter	Description	Test Conditions	Max.	Unit
C_{IN}	Input Capacitance	$T_A = 25^\circ\text{C}, f = 1 \text{ MHz}$	6	pF
C_{OUT}	Output Capacitance		8	pF

AC Test Loads and Waveforms

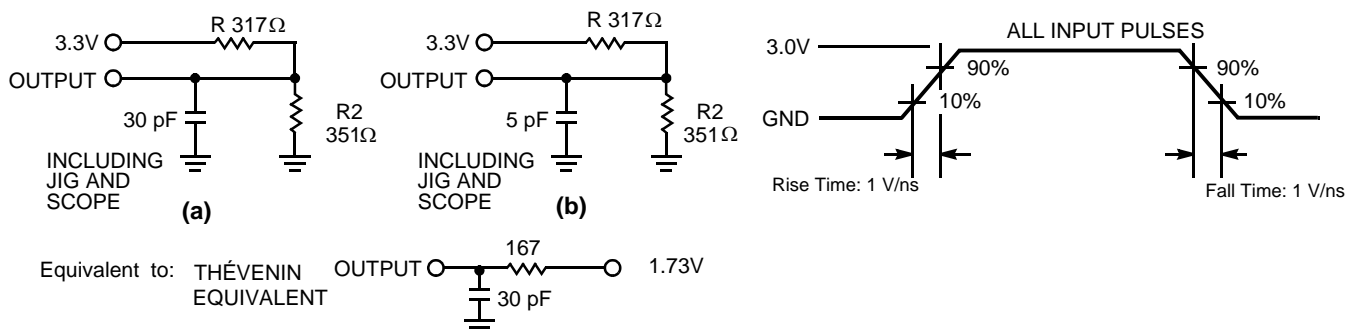

Note:

1. Minimum voltage is -2.0V for pulse durations of less than 20 ns.
2. Tested initially and after any design or process changes that may affect these parameters.

Switching Characteristics^[3] Over the Operating Range

Parameter	Description	-10		-12		-15		Unit
		Min.	Max.	Min.	Max.	Min.	Max.	
READ CYCLE								
t _{RC}	Read Cycle Time	10		12		15		ns
t _{AA}	Address to Data Valid		10		12		15	ns
t _{OHA}	Data Hold from Address Change	3		3		3		ns
t _{ACE}	\overline{CE} LOW to Data Valid		10		12		15	ns
t _{DOE}	\overline{OE} LOW to Data Valid		4		6		7	ns
t _{LZOE}	\overline{OE} LOW to Low Z	0		0		0		ns
t _{HZOE}	\overline{OE} HIGH to High Z ^[4, 5]		5		6		7	ns
t _{LZCE}	\overline{CE} LOW to Low Z ^[5]	3		3		3		ns
t _{HZCE}	\overline{CE} HIGH to High Z ^[4, 5]		5		6		7	ns
t _{PU}	\overline{CE} LOW to Power-Up	0		0		0		ns
t _{PD}	\overline{CE} HIGH to Power-Down		12		12		15	ns
t _{DBE}	Byte Enable to Data Valid		5		6		7	ns
t _{LZBE}	Byte Enable to Low Z	0		0		0		ns
t _{HZBE}	Byte Disable to High Z		5		6		7	ns
WRITE CYCLE^[6]								
t _{WC}	Write Cycle Time	10		12		15		ns
t _{SCE}	\overline{CE} LOW to Write End	8		9		10		ns
t _{AW}	Address Set-Up to Write End	7		8		10		ns
t _{HA}	Address Hold from Write End	0		0		0		ns
t _{SA}	Address Set-Up to Write Start	0		0		0		ns
t _{PWE}	\overline{WE} Pulse Width	8		8		10		ns
t _{SD}	Data Set-Up to Write End	6		6		8		ns
t _{HD}	Data Hold from Write End	0		0		0		ns
t _{LZWE}	\overline{WE} HIGH to Low Z ^[5]	3		3		3		ns
t _{HZWE}	\overline{WE} LOW to High Z ^[4, 5]		5		6		7	ns
t _{BW}	Byte Enable to End of Write	8		8		9		ns

Data Retention Characteristics Over the Operating Range (L version only)

Parameter	Description		Conditions ^[7]	Min.	Max.	Unit
V _{DR}	V _{CC} for Data Retention			2.0		V
I _{CCDR}	Data Retention Current	Com'l	V _{CC} = V _{DR} = 2.0V, CE ≥ V _{CC} - 0.3V, V _{IN} ≥ V _{CC} - 0.3V or V _{IN} ≤ 0.3V		100	μA
t _{CDR} ^[8]	Chip Deselect to Data Retention Time			0		ns
t _R ^[9]	Operation Recovery Time			t _{RC}		ns

Notes:

- Test conditions assume signal transition time of 3 ns or less, timing reference levels of 1.5V, input pulse levels of 0 to 3.0V, and output loading of the specified I_{OL}/I_{OH} and 30-pF load capacitance.
- t_{HZOE}, t_{HZBE}, t_{HZCE}, and t_{HZWE} are specified with a load capacitance of 5 pF as in part (b) of AC Test Loads. Transition is measured ±500 mV from steady-state voltage.
- At any given temperature and voltage condition, t_{HZCE} is less than t_{LZCE}, t_{HZOE} is less than t_{LZOE}, and t_{HZWE} is less than t_{LZWE} for any given device.
- The internal write time of the memory is defined by the overlap of CE LOW, WE LOW and BHE / BLE LOW. CE, WE and BHE / BLE must be LOW to initiate a write, and the transition of these signals can terminate the write. The input data set-up and hold timing should be referenced to the leading edge of the signal that terminates the write.
- No input may exceed V_{CC} + 0.5V.
- Tested initially and after any design or process changes that may affect these parameters.
- t_r ≤ 3 ns for the -12 and -15 speeds. t_r ≤ 5 ns for the -20 and slower speeds.

Data Retention Waveform

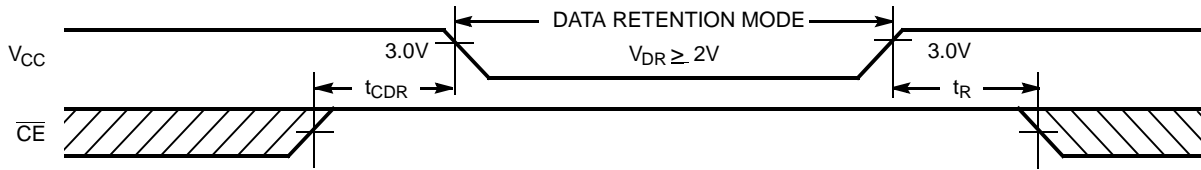

Switching Waveforms

Read Cycle No. 1^[10, 11]

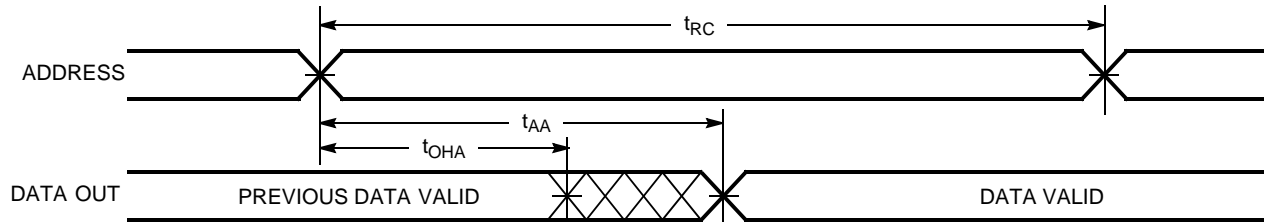

Read Cycle No. 2 (\overline{OE} Controlled)^[11, 12]

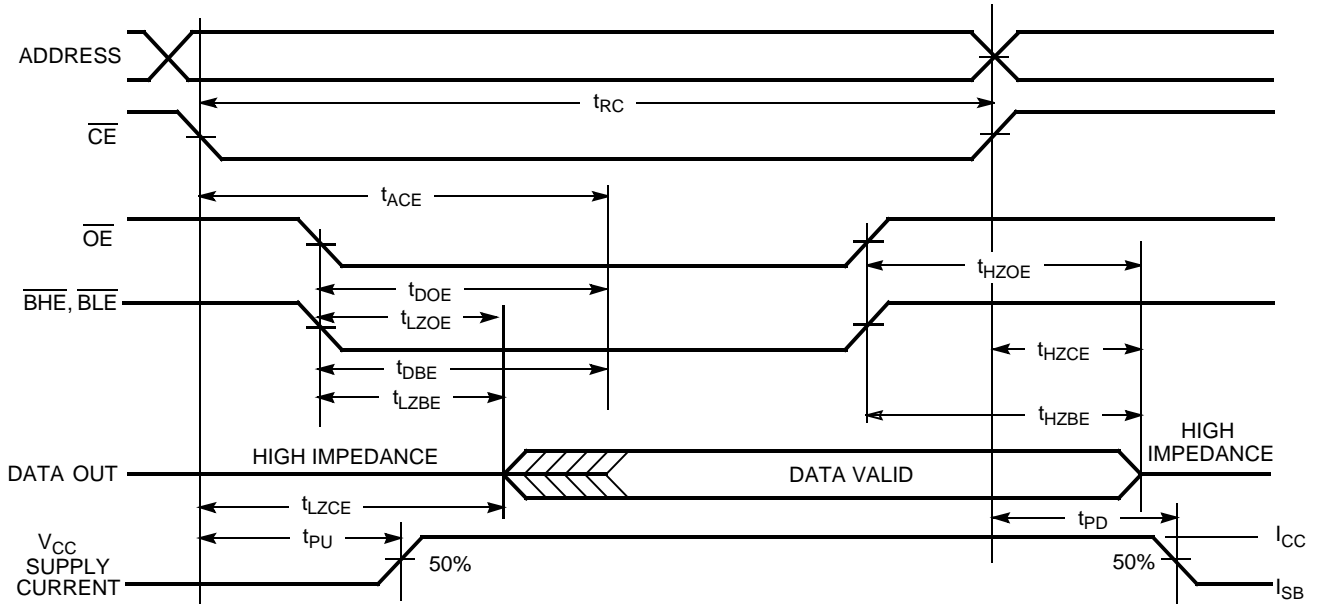

- Notes:
- 10. Device is continuously selected. \overline{OE} , \overline{CE} , \overline{BHE} and/or \overline{BLE} = V_{IL} .
 - 11. WE is HIGH for read cycle.
 - 12. Address valid prior to or coincident with \overline{CE} transition LOW.

Switching Waveforms (continued)

Write Cycle No. 1 (\overline{CE} Controlled)^[13, 14]

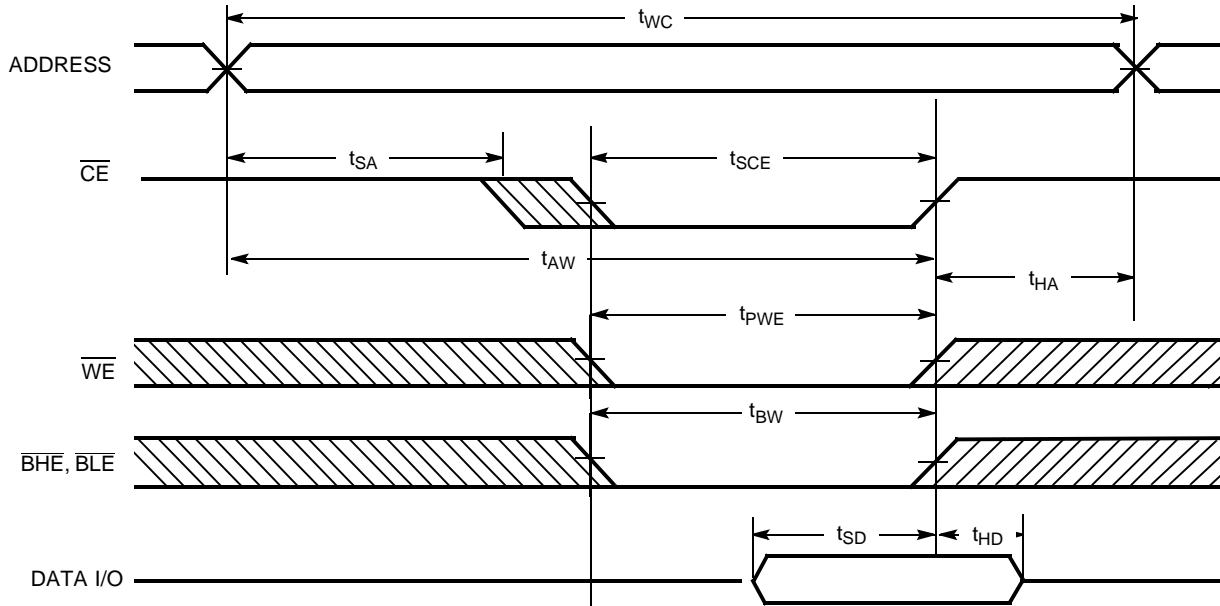

Write Cycle No. 2 (\overline{BLE} or \overline{BHE} Controlled)

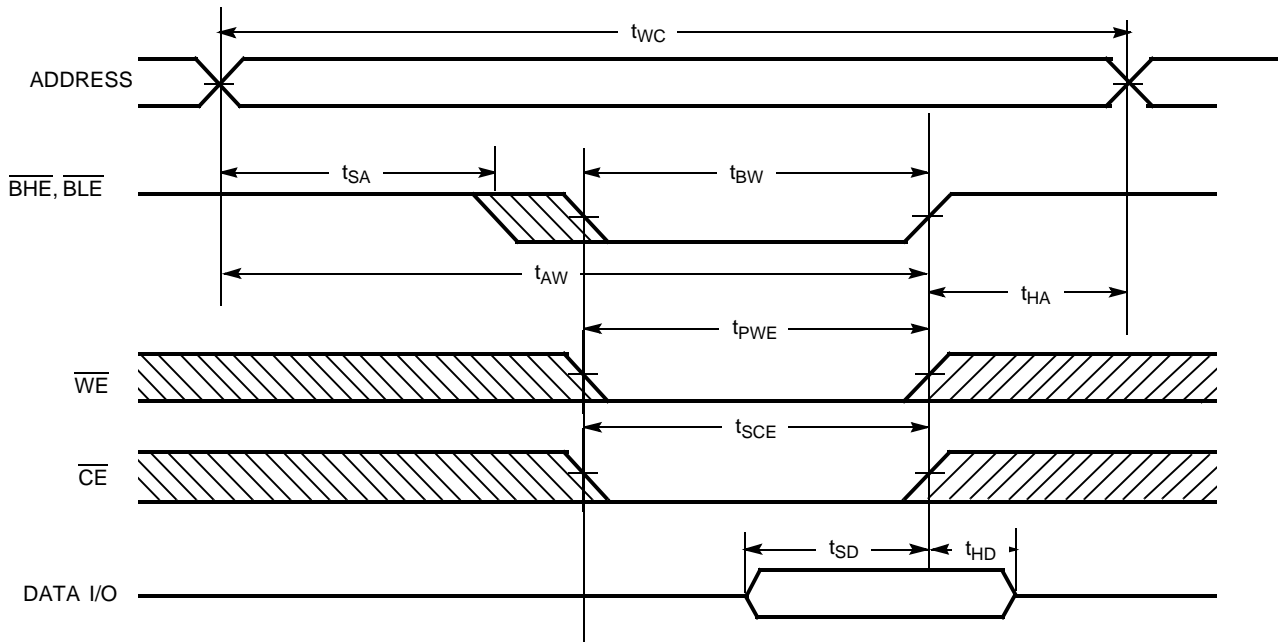

Notes:

- 13. Data I/O is high impedance if \overline{OE} or \overline{BHE} and/or $\overline{BLE} = V_{IH}$.
- 14. If \overline{CE} goes HIGH simultaneously with \overline{WE} going HIGH, the output remains in a high-impedance state.

Switching Waveforms (continued)

Write Cycle No. 2 (\overline{WE} Controlled, \overline{OE} LOW)

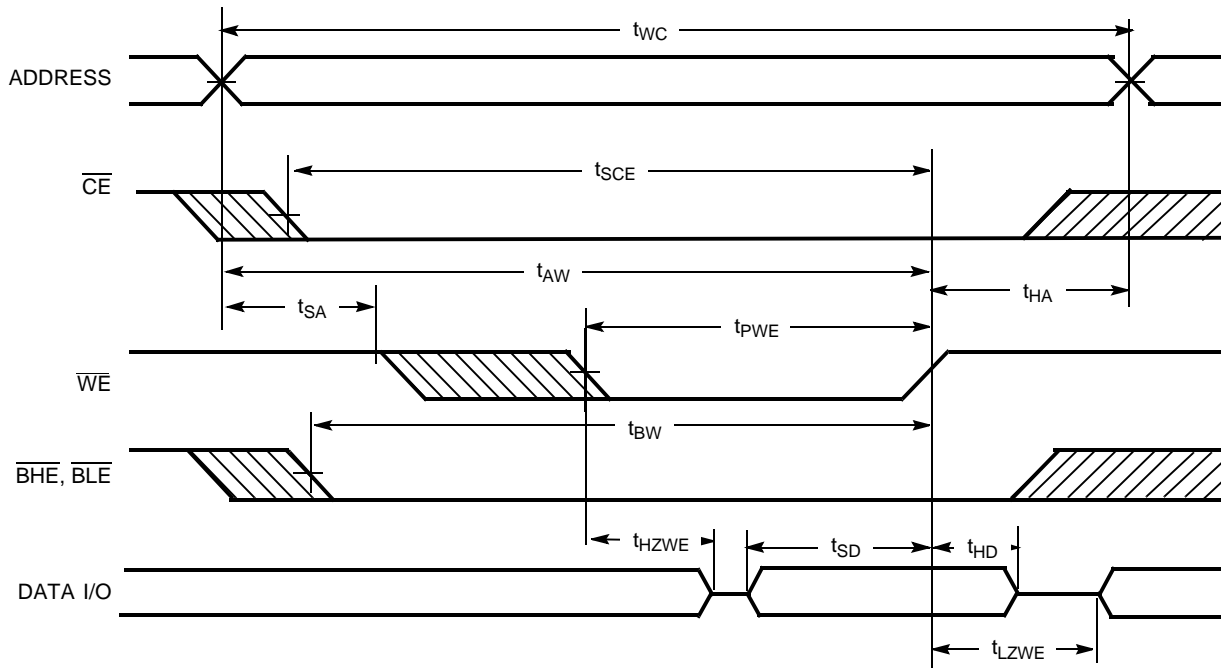

Truth Table

\overline{CE}	\overline{OE}	\overline{WE}	\overline{BLE}	\overline{BHE}	$I/O_1-I/O_8$	$I/O_9-I/O_{16}$	Mode	Power
H	X	X	X	X	High Z	High Z	Power-Down	Standby (I_{SB})
L	L	H	L	L	Data Out	Data Out	Read - All bits	Active (I_{CC})
			L	H	Data Out	High Z	Read - Lower bits only	Active (I_{CC})
			H	L	High Z	Data Out	Read - Upper bits only	Active (I_{CC})
L	X	L	L	L	Data In	Data In	Write - All bits	Active (I_{CC})
			L	H	Data In	High Z	Write - Lower bits only	Active (I_{CC})
			H	L	High Z	Data In	Write - Upper bits only	Active (I_{CC})
L	H	H	X	X	High Z	High Z	Selected, Outputs Disabled	Active (I_{CC})
L	X	X	H	H	High Z	High Z	Selected, Outputs Disabled	Active (I_{CC})

Ordering Information

Speed (ns)	Ordering Code	Package Diagram	Package Type	Operating Range
10	CY7C1021BNV33L-10VXC	51-85082	44-Lead (400-Mil) Molded SOJ (Pb-free)	Commercial
	CY7C1021BNV33L-10ZXC	51-85087	44-Lead TSOP Type II (Pb-free)	
12	CY7C1021BNV33L-12ZC	51-85087	44-Lead TSOP Type II	
	CY7C1021BNV33L-12ZXC	51-85087	44-Lead TSOP Type II (Pb-free)	
15	CY7C1021BNV33L-15ZC	51-85087	44-Lead TSOP Type II	
	CY7C1021BNV33L-15ZXC	51-85087	44-Lead TSOP Type II (Pb-free)	
	CY7C1021BNV33L-15VXC	51-85082	44-Lead (400-Mil) Molded SOJ (Pb-free)	
	CY7C1021BNV33L-15BAI	51-85096	48-ball Mini Ball Grid Array (7 mm x 7 mm)	
	CY7C1021BNV33L-15VXI	51-85082	44-Lead (400-Mil) Molded SOJ (Pb-free)	
	CY7C1021BNV33L-15ZXI	51-85087	44-Lead TSOP Type II (Pb-free)	
CY7C1021BNV33L-15ZI	51-85087	44-Lead TSOP Type II		

Please contact local sales representative regarding availability of these parts.

Package Diagrams

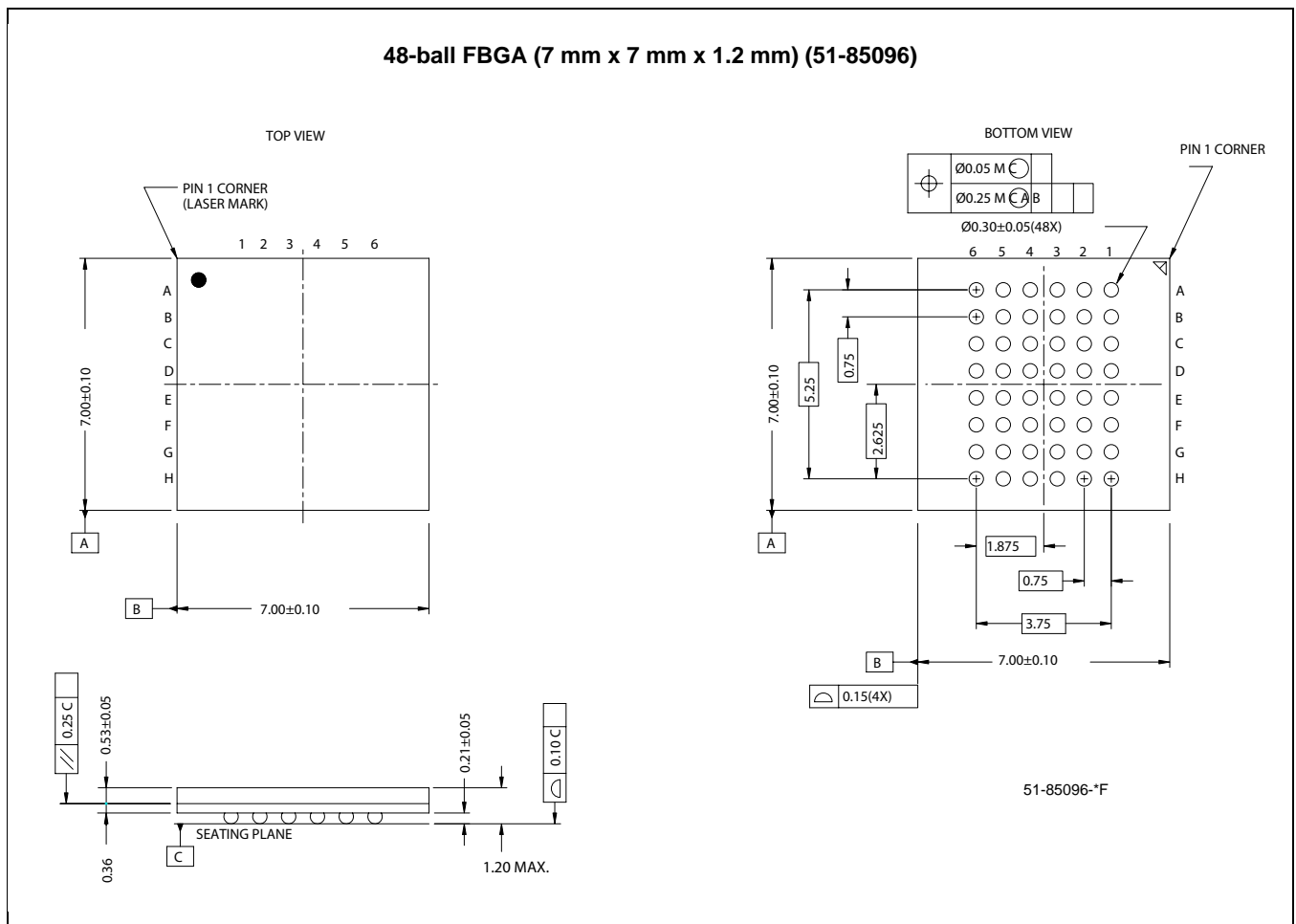

Package Diagrams (continued)

44-Lead (400-Mil) Molded SOJ (51-85082)

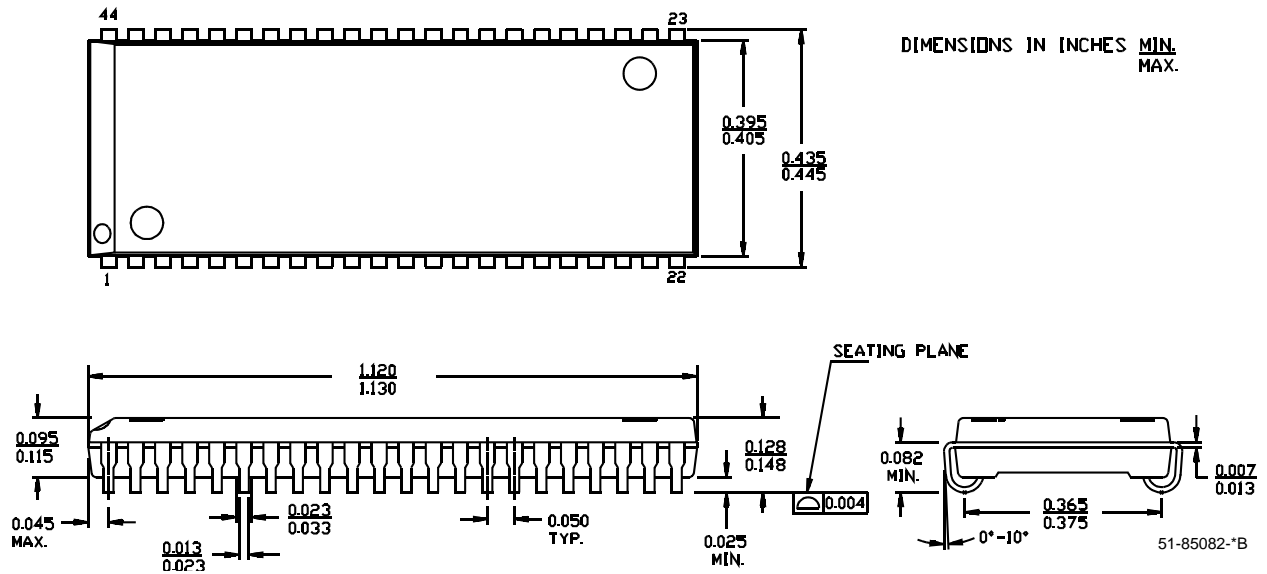

44-Pin TSOP Type II (51-85087)

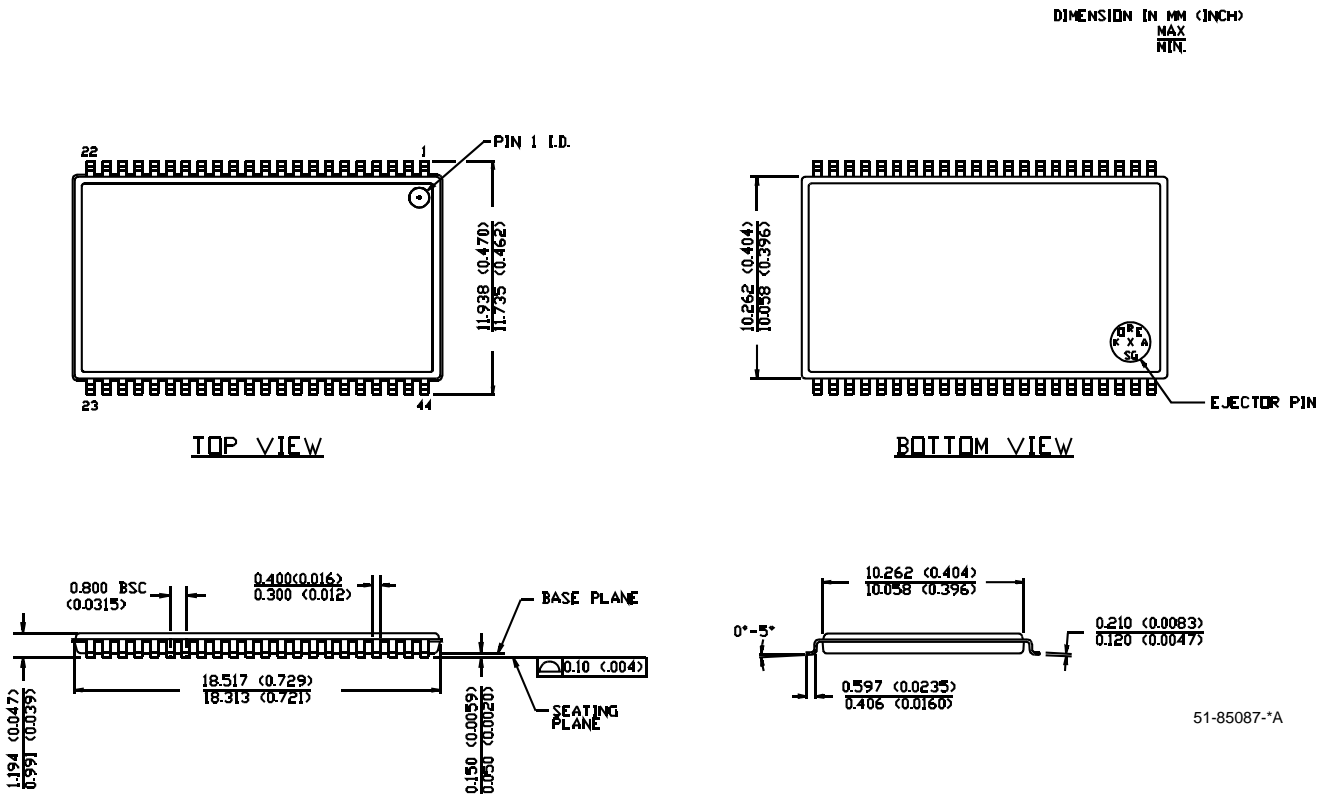

All product and company names mentioned in this document may be the trademarks of their respective holders.



Document History Page

Document Title: CY7C1021BNV33 64K x 16 Static RAM Document Number: 001-06433				
REV.	ECN NO.	Issue Date	Orig. of Change	Description of Change
**	423847	See ECN	NXR	New Data Sheet