

BS170

Preferred Device

Small Signal MOSFET 500 mA, 60 Volts N-Channel TO-92 (TO-226)

Features

- Pb-Free Package is Available*

MAXIMUM RATINGS

Rating	Symbol	Value	Unit
Drain-Source Voltage	V_{DS}	60	Vdc
Gate-Source Voltage - Continuous - Non-repetitive ($t_p \leq 50 \mu s$)	V_{GS} V_{GSM}	± 20 ± 40	Vdc Vpk
Drain Current (Note)	I_D	0.5	Adc
Total Device Dissipation @ $T_A = 25^\circ C$	P_D	350	mW
Operating and Storage Junction Temperature Range	T_J, T_{stg}	-55 to +150	$^\circ C$

Maximum ratings are those values beyond which device damage can occur. Maximum ratings applied to the device are individual stress limit values (not normal operating conditions) and are not valid simultaneously. If these limits are exceeded, device functional operation is not implied, damage may occur and reliability may be affected.

NOTE: The Power Dissipation of the package may result in a lower continuous drain current.



ON Semiconductor®

<http://onsemi.com>

500 mA, 60 Volts
 $R_{DS(on)} = 5.0 \Omega$

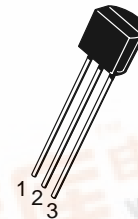
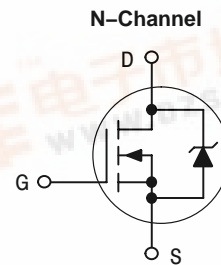

TO-92 (TO-226)
CASE 29
STYLE 30

MARKING DIAGRAM & PIN ASSIGNMENT

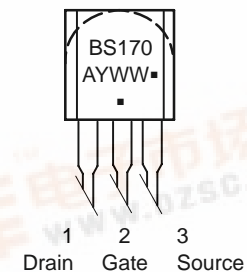

BS170 = Device Code
A = Assembly Location
Y = Year
WW = Work Week
▪ = Pb-Free Package
(Note: Microdot may be in either location)

ORDERING INFORMATION

See detailed ordering and shipping information in the package dimensions section on page 2 of this data sheet.

Preferred devices are recommended choices for future use and best overall value.



For additional information on our Pb-Free strategy and soldering details, please download the ON Semiconductor Soldering and Mounting Techniques Reference Manual, SOLDERRM/D.

BS170

ELECTRICAL CHARACTERISTICS (T_A = 25°C unless otherwise noted)

Characteristic	Symbol	Min	Typ	Max	Unit
OFF CHARACTERISTICS					
Gate Reverse Current (V _{GS} = 15 Vdc, V _{DS} = 0)	I _{GSS}	–	0.01	10	nAdc
Drain–Source Breakdown Voltage (V _{GS} = 0, I _D = 100 μAdc)	V _{(BR)DSS}	60	90	–	Vdc

ON CHARACTERISTICS (Note 1)

Gate Threshold Voltage (V _{DS} = V _{GS} , I _D = 1.0 mAdc)	V _{GS(Th)}	0.8	2.0	3.0	Vdc
Static Drain–Source On Resistance (V _{GS} = 10 Vdc, I _D = 200 mAdc)	r _{DS(on)}	–	1.8	5.0	Ω
Drain Cutoff Current (V _{DS} = 25 Vdc, V _{GS} = 0 Vdc)	I _{D(off)}	–	–	0.5	μA
Forward Transconductance (V _{DS} = 10 Vdc, I _D = 250 mAdc)	g _{fs}	–	200	–	mmhos

SMALL–SIGNAL CHARACTERISTICS

Input Capacitance (V _{DS} = 10 Vdc, V _{GS} = 0, f = 1.0 MHz)	C _{iss}	–	–	60	pF
---	------------------	---	---	----	----

SWITCHING CHARACTERISTICS

Turn–On Time (I _D = 0.2 Adc) See Figure 1	t _{on}	–	4.0	10	ns
Turn–Off Time (I _D = 0.2 Adc) See Figure 1	t _{off}	–	4.0	10	ns

1. Pulse Test: Pulse Width ≤ 300 μs, Duty Cycle ≤ 2.0%.

ORDERING INFORMATION

Device	Package	Shipping†
BS170	TO–92 (TO–226)	1000 Unit/Tube
BS170G	TO–92 (TO–226) (Pb–Free)	1000 Unit/Tube
BS170RLRA	TO–92 (TO–226)	2000 Tape & Reel
BS170RLRAG	TO–92 (TO–226) (Pb–Free)	2000 Tape & Reel
BS170RLRM	TO–92 (TO–226)	2000 Tape & Reel
BS170RLRMG	TO–92 (TO–226) (Pb–Free)	2000 Tape & Reel
BS170RLRP	TO–92 (TO–226)	2000 Tape & Reel
BS170RLRPG	TO–92 (TO–226) (Pb–Free)	2000 Tape & Reel
BS170RL1	TO–92 (TO–226)	2000 Tape & Reel
BS170RL1G	TO–92 (TO–226) (Pb–Free)	2000 Tape & Reel
BS170ZL1	TO–92 (TO–226)	2000 Tape & Reel
BS170ZL1G	TO–92 (TO–226) (Pb–Free)	2000 Tape & Reel

†For information on tape and reel specifications, including part orientation and tape sizes, please refer to our Tape and Reel Packaging Specifications Brochure, BRD8011/D.

BS170

RESISTIVE SWITCHING

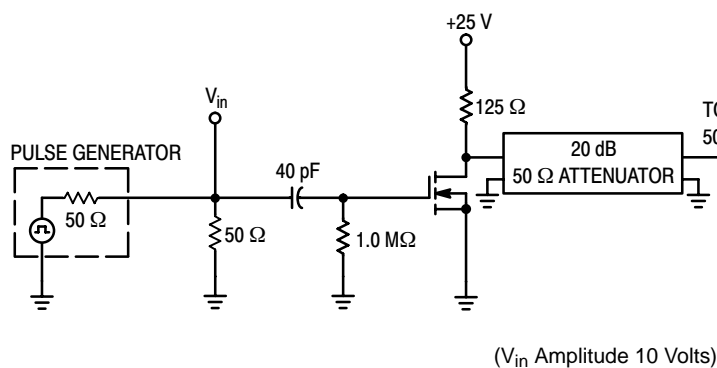

Figure 1. Switching Test Circuit

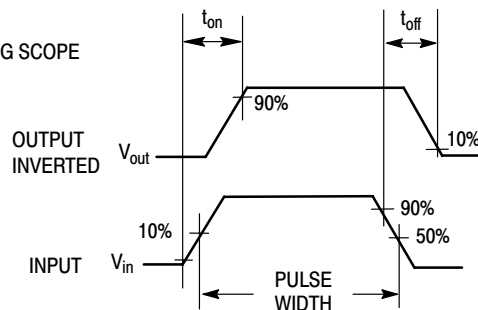

Figure 2. Switching Waveforms

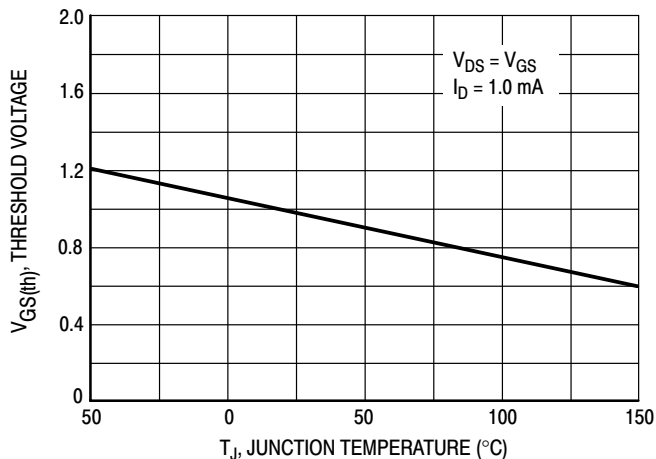

Figure 3. $V_{GS(th)}$ Normalized versus Temperature

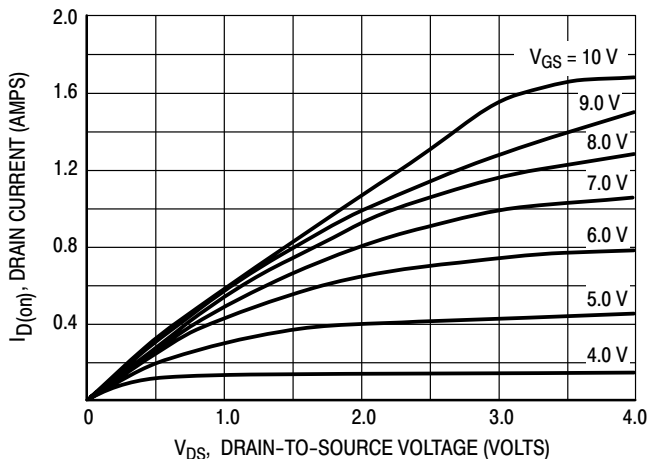

Figure 4. On-Region Characteristics

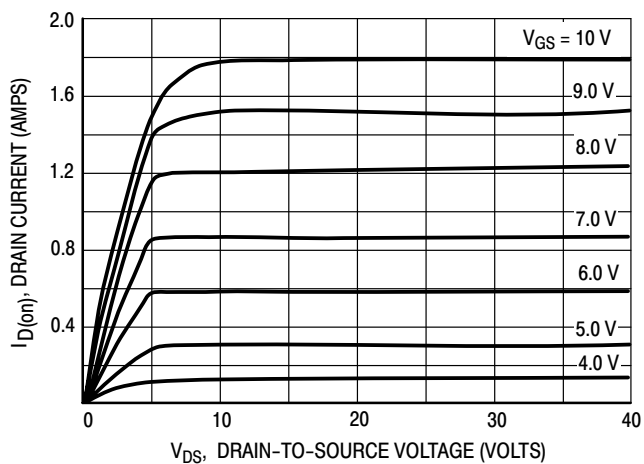

Figure 5. Output Characteristics

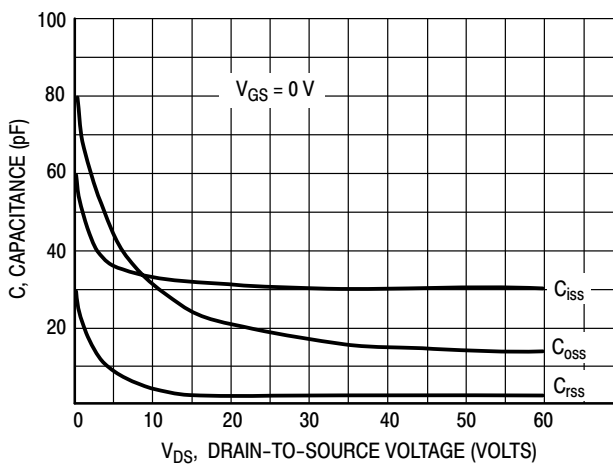
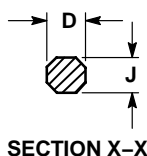
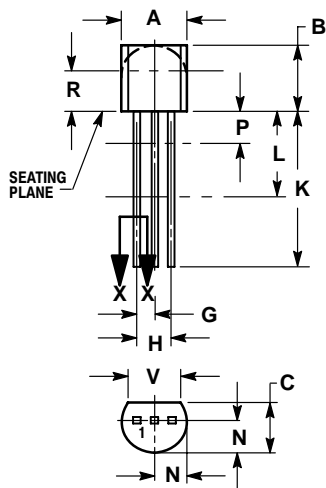

Figure 6. Capacitance versus Drain-To-Source Voltage

BS170

PACKAGE DIMENSIONS

TO-92 (TO-226) CASE 29-11 ISSUE AL



NOTES:

1. DIMENSIONING AND TOLERANCING PER ANSI Y14.5M, 1982.
2. CONTROLLING DIMENSION: INCH.
3. CONTOUR OF PACKAGE BEYOND DIMENSION R IS UNCONTROLLED.
4. LEAD DIMENSION IS UNCONTROLLED IN P AND BEYOND DIMENSION K MINIMUM.

DIM	INCHES		MILLIMETERS	
	MIN	MAX	MIN	MAX
A	0.175	0.205	4.45	5.20
B	0.170	0.210	4.32	5.33
C	0.125	0.165	3.18	4.19
D	0.016	0.021	0.407	0.533
G	0.045	0.055	1.15	1.39
H	0.095	0.105	2.42	2.66
J	0.015	0.020	0.39	0.50
K	0.500	---	12.70	---
L	0.250	---	6.35	---
N	0.080	0.105	2.04	2.66
P	---	0.100	---	2.54
R	0.115	---	2.93	---
V	0.135	---	3.43	---

STYLE 30:

- PIN 1. DRAIN
- GATE
- SOURCE

ON Semiconductor and  are registered trademarks of Semiconductor Components Industries, LLC (SCILLC). SCILLC reserves the right to make changes without further notice to any products herein. SCILLC makes no warranty, representation or guarantee regarding the suitability of its products for any particular purpose, nor does SCILLC assume any liability arising out of the application or use of any product or circuit, and specifically disclaims any and all liability, including without limitation special, consequential or incidental damages. "Typical" parameters which may be provided in SCILLC data sheets and/or specifications can and do vary in different applications and actual performance may vary over time. All operating parameters, including "Typicals" must be validated for each customer application by customer's technical experts. SCILLC does not convey any license under its patent rights nor the rights of others. SCILLC products are not designed, intended, or authorized for use as components in systems intended for surgical implant into the body, or other applications intended to support or sustain life, or for any other application in which the failure of the SCILLC product could create a situation where personal injury or death may occur. Should Buyer purchase or use SCILLC products for any such unintended or unauthorized application, Buyer shall indemnify and hold SCILLC and its officers, employees, subsidiaries, affiliates, and distributors harmless against all claims, costs, damages, and expenses, and reasonable attorney fees arising out of, directly or indirectly, any claim of personal injury or death associated with such unintended or unauthorized use, even if such claim alleges that SCILLC was negligent regarding the design or manufacture of the part. SCILLC is an Equal Opportunity/Affirmative Action Employer. This literature is subject to all applicable copyright laws and is not for resale in any manner.

PUBLICATION ORDERING INFORMATION

LITERATURE FULFILLMENT:

Literature Distribution Center for ON Semiconductor
P.O. Box 61312, Phoenix, Arizona 85082-1312 USA
Phone: 480-829-7710 or 800-344-3860 Toll Free USA/Canada
Fax: 480-829-7709 or 800-344-3867 Toll Free USA/Canada
Email: orderlit@onsemi.com

N. American Technical Support: 800-282-9855 Toll Free
USA/Canada

Japan: ON Semiconductor, Japan Customer Focus Center
2-9-1 Kamimeguro, Meguro-ku, Tokyo, Japan 153-0051
Phone: 81-3-5773-3850

ON Semiconductor Website: <http://onsemi.com>

Order Literature: <http://www.onsemi.com/litorder>

For additional information, please contact your local Sales Representative.