



CAT28F020

2 Megabit CMOS Flash Memory

Licensed Intel second source

FEATURES

- Fast read access time: 90/120 ns
- Low power CMOS dissipation:
 - Active: 30 mA max (CMOS/TTL levels)
 - Standby: 1 mA max (TTL levels)
 - Standby: 100 μ A max (CMOS levels)
- High speed programming:
 - 10 μ s per byte
 - 4 seconds typical chip program
- 0.5 seconds typical chip-erase
- 12.0V \pm 5% programming and erase voltage
- Commercial, industrial and automotive temperature ranges
- Stop timer for program/erase
- On-chip address and data latches
- JEDEC standard pinouts:
 - 32-pin DIP
 - 32-pin PLCC
 - 32-pin TSOP (8 x 20)
- 100,000 program/erase cycles
- 10 year data retention
- Electronic signature

DESCRIPTION

The CAT28F020 is a high speed 256K x 8-bit electrically erasable and reprogrammable Flash memory ideally suited for applications requiring in-system or after-sale code updates. Electrical erasure of the full memory contents is achieved typically within 0.5 second.

It is pin and Read timing compatible with standard EPROM and E²PROM devices. Programming and Erase are performed through an operation and verify algorithm. The instructions are input via the I/O bus,

using a two write cycle scheme. Address and Data are latched to free the I/O bus and address bus during the write operation.

The CAT28F020 is manufactured using Catalyst's advanced CMOS floating gate technology. It is designed to endure 100,000 program/erase cycles and has a data retention of 10 years. The device is available in JEDEC approved 32-pin plastic DIP, 32-pin PLCC or 32-pin TSOP packages.

BLOCK DIAGRAM

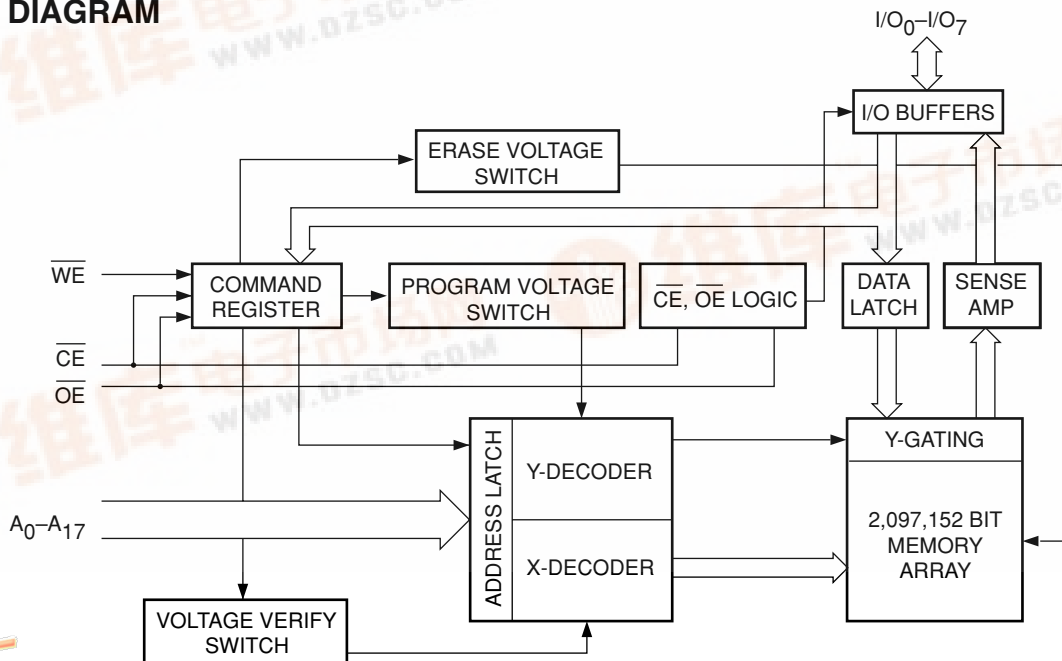

PIN CONFIGURATION

DIP Package (P, L)

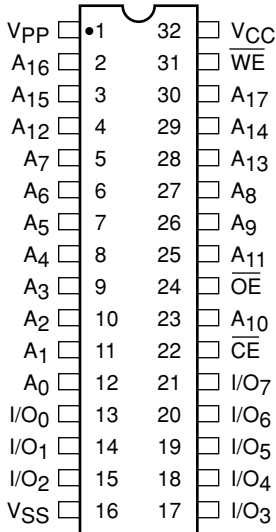

PLCC Package (N, G)

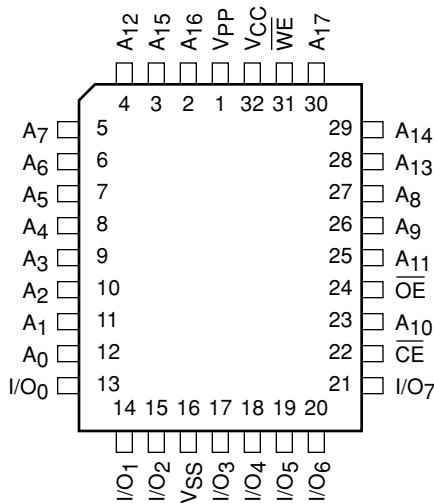

ABSOLUTE MAXIMUM RATINGS*

Temperature Under Bias –55°C to +95°C
 Storage Temperature –65°C to +150°C
 Voltage on Any Pin with
 Respect to Ground⁽¹⁾ –2.0V to +V_{CC} + 2.0V
 Voltage on Pin A₉ with
 Respect to Ground⁽¹⁾ –2.0V to +13.5V
 V_{PP} with Respect to Ground
 during Program/Erase⁽¹⁾ –2.0V to +14.0V
 V_{CC} with Respect to Ground⁽¹⁾ –2.0V to +7.0V
 Package Power Dissipation
 Capability (T_A = 25°C) 1.0 W
 Lead Soldering Temperature (10 secs) 300°C
 Output Short Circuit Current⁽²⁾ 100 mA

***COMMENT**

Stresses above those listed under “Absolute Maximum Ratings” may cause permanent damage to the device. These are stress ratings only, and functional operation of the device at these or any other conditions outside of those listed in the operational sections of this specification is not implied. Exposure to any absolute maximum rating for extended periods may affect device performance and reliability.

RELIABILITY CHARACTERISTICS

Symbol	Parameter	Test Method	Min	Typ	Max	Units
N _{END} ⁽³⁾	Endurance	MIL-STD-883, Test Method 1033	100K			Cycles/Byte
T _{DR} ⁽³⁾	Data Retention	MIL-STD-883, Test Method 1008	10			Years
V _{ZAP} ⁽³⁾	ESD Susceptibility	MIL-STD-883, Test Method 3015	2000			Volts
I _{LTH} ⁽³⁾⁽⁴⁾	Latch-Up	JEDEC Standard 17	100			mA

CAPACITANCE T_A = 25°C, f = 1.0 MHz

Symbol	Test	Conditions	Min	Typ	Max	Units
C _{IN} ⁽³⁾	Input Pin Capacitance	V _{IN} = 0V			6	pF
C _{OUT} ⁽³⁾	Output Pin Capacitance	V _{OUT} = 0V			10	pF
C _{VPP} ⁽³⁾	V _{PP} Supply Capacitance	V _{PP} = 0V			25	pF

Note:

1. The minimum DC input voltage is –0.5V. During transitions, inputs may undershoot to –2.0V for periods of less than 20 ns. Maximum DC voltage on output pins is V_{CC} +0.5V, which may overshoot to V_{CC} + 2.0V for periods of less than 20ns.
2. Output shorted for no more than one second. No more than one output shorted at a time.
3. This parameter is tested initially and after a design or process change that affects the parameter.
4. Latch-up protection is provided for stresses up to 100 mA on address and data pins from –1V to V_{CC} +1V.

D.C. OPERATING CHARACTERISTICS

V_{CC} = +5V ±10%, unless otherwise specified. (See Note 2)

Symbol	Parameter	Test Conditions	Min	Typ	Max	Unit
I _{LI}	Input Leakage Current	V _{IN} = V _{CC} or V _{SS} V _{CC} = 5.5V, $\overline{OE} = V_{IH}$			±1	μA
I _{LO}	Output Leakage Current	V _{OUT} = V _{CC} or V _{SS} , V _{CC} = 5.5V, $\overline{OE} = V_{IH}$			±1	μA
I _{SB1}	V _{CC} Standby Current CMOS	$\overline{CE} = V_{CC} \pm 0.5V$, V _{CC} = 5.5V			100	μA
I _{SB2}	V _{CC} Standby Current TTL	$\overline{CE} = V_{IH}$, V _{CC} = 5.5V			1	mA
I _{CC1}	V _{CC} Active Read Current	V _{CC} = 5.5V, CE = V _{IL} , I _{OUT} = 0mA, f = 6 MHz			30	mA
I _{CC2} ⁽¹⁾	V _{CC} Programming Current	V _{CC} = 5.5V, Programming in Progress			15	mA
I _{CC3} ⁽¹⁾	V _{CC} Erase Current	V _{CC} = 5.5V, Erasure in Progress			15	mA
I _{CC4} ⁽¹⁾	V _{CC} Prog./Erase Verify Current	V _{CC} = 5.5V, Program or Erase Verify in Progress			15	mA
I _{PPS}	V _{PP} Standby Current	V _{PP} = V _{PPL}			±10	μA
I _{PP1}	V _{PP} Read Current	V _{PP} = V _{PPH}			200	μA
I _{PP2} ⁽¹⁾	V _{PP} Programming Current	V _{PP} = V _{PPH} , Programming in Progress			30	mA
I _{PP3} ⁽¹⁾	V _{PP} Erase Current	V _{PP} = V _{PPH} , Erasure in Progress			30	mA
I _{PP4} ⁽¹⁾	V _{PP} Prog./Erase Verify Current	V _{PP} = V _{PPH} , Program or Erase Verify in Progress			5	mA
V _{IL}	Input Low Level TTL		-0.5		0.8	V
V _{ILC}	Input Low Level CMOS		-0.5		0.8	V
V _{OL}	Output Low Level	I _{OL} = 5.8mA, V _{CC} ⁽²⁾ = 4.5V			0.45	V
V _{IH}	Input High Level TTL		2		V _{CC} +0.5	V
V _{IHC}	Input High Level CMOS		V _{CC} *0.7		V _{CC} +0.5	V
V _{OH1}	Output High Level TTL	I _{OH} = -2.5mA, V _{CC} ⁽²⁾ = 4.5V	2.4			V
V _{OH2}	Output High Level CMOS	I _{OH} = -400μA, V _{CC} ⁽²⁾ = 4.5V	V _{CC} -0.4			V
V _{ID}	A ₉ Signature Voltage	A ₉ = V _{ID}	11.4		13	V
I _{ID} ⁽¹⁾	A ₉ Signature Current	A ₉ = V _{ID}			200	μA
V _{LO}	V _{CC} Erase/Prog. Lockout Voltage		2.5			V

Note:

1. This parameter is tested initially and after a design or process change that affects the parameter.
2. CAT28F020-90, V_{CCMIN} = 4.75 V.

SUPPLY CHARACTERISTICS

Symbol	Parameter		Min	Typ	Max	Unit
VCC	VCC Supply Voltage	28F020-90	4.75		5.5	V
		28F020-12	4.5		5.5	V
VPPL	VPP During Read Operations		0		6.5	V
VPPH	VPP During Read/Erase/Program		11.4		12.6	V

A.C. CHARACTERISTICS, Read Operation

V_{CC} = +5V ±10%, unless otherwise specified. (See Note 8)

JEDEC Symbol	Standard Symbol	Parameter	28F020-90 ⁽⁷⁾			28F020-12 ⁽⁷⁾			Unit
			Min	Typ	Max	Min	Typ	Max	
t _{AVAV}	t _{RC}	Read Cycle Time	90			120			ns
t _{ELQV}	t _{CE}	\overline{CE} Access Time			90			120	ns
t _{AVQV}	t _{ACC}	Address Access Time			90			120	ns
t _{GLQV}	t _{OE}	\overline{OE} Access Time			35			50	ns
t _{AXQX}	t _{OH}	Output Hold from Address $\overline{OE}/\overline{CE}$ Change	0			0			ns
t _{GLQX}	t _{OLZ} ⁽¹⁾⁽⁶⁾	\overline{OE} to Output in Low-Z	0			0			ns
t _{ELQX}	t _{LZ} ⁽¹⁾⁽⁶⁾	\overline{CE} to Output in Low-Z	0			0			ns
t _{GHQZ}	t _{DF} ⁽¹⁾⁽²⁾	\overline{OE} High to Output High-Z			30			30	ns
t _{EHQZ}	t _{DF} ⁽¹⁾⁽²⁾	\overline{CE} High to Output High-Z			40			40	ns
t _{WHGL} ⁽¹⁾	-	Write Recovery Time Before Read	6			6			µs

Figure 1. A.C. Testing Input/Output Waveform⁽³⁾⁽⁴⁾⁽⁵⁾

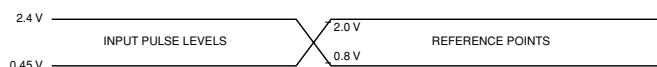

Testing Load Circuit (example)

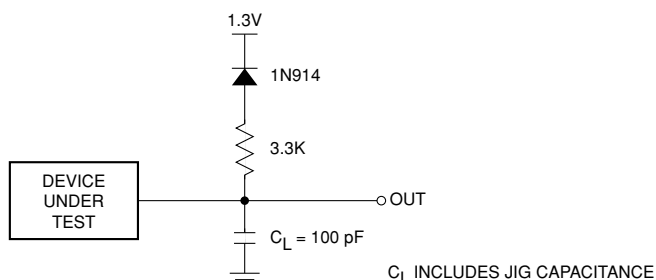

Note:

1. This parameter is tested initially and after a design or process change that affects the parameter.
2. Output floating (High-Z) is defined as the state where the external data line is no longer driven by the output buffer.
3. Input Rise and Fall Times (10% to 90%) < 10 ns.
4. Input Pulse Levels = 0.45 V and 2.4 V. For High Speed Input Pulse Levels 0.0 V and 3.0 V.
5. Input and Output Timing Reference = 0.8 V and 2.0 V. For High Speed Input and Output Timing Reference = 1.5 V.
6. Low-Z is defined as the state where the external data may be driven by the output buffer but may not be valid.
7. For load and reference points, see Fig. 1.
8. CAT28F020-90, V_{CCMIN} = 4.75 V.

CAT28F020

A.C. CHARACTERISTICS, Program/Erase Operation

$V_{CC} = +5V \pm 10\%$, unless otherwise specified. (See Note 6)

JEDEC Symbol	Standard Symbol	Parameter	28F020-90			28F020-12			Unit
			Min	Typ	Max	Min	Typ	Max	
t _{AVAV}	t _{WC}	Write Cycle Time	90			120			ns
t _{AVWL}	t _{AS}	Address Setup Time	0			0			ns
t _{WLAX}	t _{AH}	Address Hold Time	40			40			ns
t _{DVWH}	t _{DS}	Data Setup Time	40			40			ns
t _{WHDX}	t _{DH}	Data Hold Time	10			10			ns
t _{ELWL}	t _{CS}	\overline{CE} Setup Time	0			0			ns
t _{WHEH}	t _{CH}	\overline{CE} Hold Time	0			0			ns
t _{WLWH}	t _{WP}	\overline{WE} Pulse Width	40			40			ns
t _{WHWL}	t _{WPH}	\overline{WE} High Pulse Width	20			20			ns
t _{WHWH1} ⁽²⁾	-	Program Pulse Width	10			10			μs
t _{WHWH2} ⁽²⁾	-	Erase Pulse Width	9.5			9.5			ms
t _{WHGL}	-	Write Recovery Time Before Read	6			6			μs
t _{GHWL}	-	Read Recovery Time Before Write	0			0			μs
t _{VPEL}	-	V _{PP} Setup Time to \overline{CE}	100			100			ns

ERASE AND PROGRAMMING PERFORMANCE⁽¹⁾

Parameter	28F020-90			28F020-12			Unit
	Min	Typ	Max	Min	Typ	Max	
Chip Erase Time ⁽³⁾⁽⁵⁾		0.5	10		0.5	10	sec
Chip Program Time ⁽³⁾⁽⁴⁾		4	25		4	25	sec

Note:

1. Please refer to Supply characteristics for the value of V_{PPH} and V_{PPL}. The V_{PP} supply can be either hardwired or switched. If V_{PP} is switched, V_{PPL} can be ground, less than V_{CC} + 2.0V or a no connect with a resistor tied to ground.
2. Program and Erase operations are controlled by internal stop timers.
3. 'Typicals' are not guaranteed, but based on characterization data. Data taken at 25°C, 12.0V V_{PP}.
4. Minimum byte programming time (excluding system overhead) is 16 μs (10 μs program + 6 μs write recovery), while maximum is 400 μs/byte (16 μs x 25 loops). Max chip programming time is specified lower than the worst case allowed by the programming algorithm since most bytes program significantly faster than the worst case byte.
5. Excludes 00H Programming prior to Erasure.
6. CAT28F020-90, V_{CCMIN} = 4.75 V

FUNCTION TABLE(1)

Mode	Pins					Notes
	\overline{CE}	\overline{OE}	\overline{WE}	V _{PP}	I/O	
Read	V _{IL}	V _{IL}	V _{IH}	V _{PPL}	D _{OUT}	
Output Disable	V _{IL}	V _{IH}	V _{IH}	X	High-Z	
Standby	V _{IH}	X	X	V _{PPL}	High-Z	
Signature (MFG)	V _{IL}	V _{IL}	V _{IH}	X	31H	A ₀ = V _{IL} , A ₉ = 12V
Signature (Device)	V _{IL}	V _{IL}	V _{IH}	X	BDH	A ₀ = V _{IH} , A ₉ = 12V
Program/Erase	V _{IL}	V _{IH}	V _{IL}	V _{PPH}	D _{IN}	See Command Table
Write Cycle	V _{IL}	V _{IH}	V _{IL}	V _{PPH}	D _{IN}	During Write Cycle
Read Cycle	V _{IL}	V _{IL}	V _{IH}	V _{PPH}	D _{OUT}	During Write Cycle

WRITE COMMAND TABLE

Commands are written into the command register in one or two write cycles. The command register can be altered only when V_{pp} is high and the instruction byte is latched on the rising edge of \overline{WE} . Write cycles also internally latch addresses and data required for programming and erase operations.

Mode	Pins						
	First Bus Cycle			Second Bus Cycle			
	Operation	Address	D _{IN}	Operation	Address	D _{IN}	D _{OUT}
Set Read	Write	X	00H	Read	A _{IN}		D _{OUT}
Read Sig. (MFG)	Write	X	90H	Read	00		31H
Read Sig. (Device)	Write	X	90H	Read	01		BDH
Erase	Write	X	20H	Write	X	20H	
Erase Verify	Write	A _{IN}	A0H	Read	X		D _{OUT}
Program	Write	X	40H	Write	A _{IN}	D _{IN}	
Program Verify	Write	X	C0H	Read	X		D _{OUT}
Reset	Write	X	FFH	Write	X	FFH	

Note:

1. Logic Levels: X = Logic 'Do not care' (V_{IH}, V_{IL}, V_{PPL}, V_{PPH})

READ OPERATIONS

Read Mode

A Read operation is performed with both \overline{CE} and \overline{OE} low and with \overline{WE} high. V_{PP} can be either high or low, however, if V_{PP} is high, the Set READ command has to be sent before reading data (see Write Operations). The data retrieved from the I/O pins reflects the contents of the memory location corresponding to the state of the 18 address pins. The respective timing waveforms for the read operation are shown in Figure 3. Refer to the AC Read characteristics for specific timing parameters.

Signature Mode

The signature mode allows the user to identify the IC manufacturer and the type of device while the device resides in the target system. This mode can be activated in either of two ways; through the conventional method of applying a high voltage (12V) to address pin A_9 or by sending an instruction to the command register (see Write Operations).

The conventional mode is entered as a regular READ mode by driving the \overline{CE} and \overline{OE} pins low (with \overline{WE} high), and applying the required high voltage on address pin A_9 while all other address lines are held at V_{IL} .

A Read cycle from address 0000H retrieves the binary code for the IC manufacturer on outputs I/O₀ to I/O₇:

$$\text{CATALYST Code} = 00110001 (31H)$$

A Read cycle from address 0001H retrieves the binary code for the device on outputs I/O₀ to I/O₇.

$$28F020 \text{ Code} = 1011 1101 (BDH)$$

Standby Mode

With \overline{CE} at a logic-high level, the CAT28F020 is placed in a standby mode where most of the device circuitry is disabled, thereby substantially reducing power consumption. The outputs are placed in a high-impedance state.

Figure 3. A.C. Timing for Read Operation

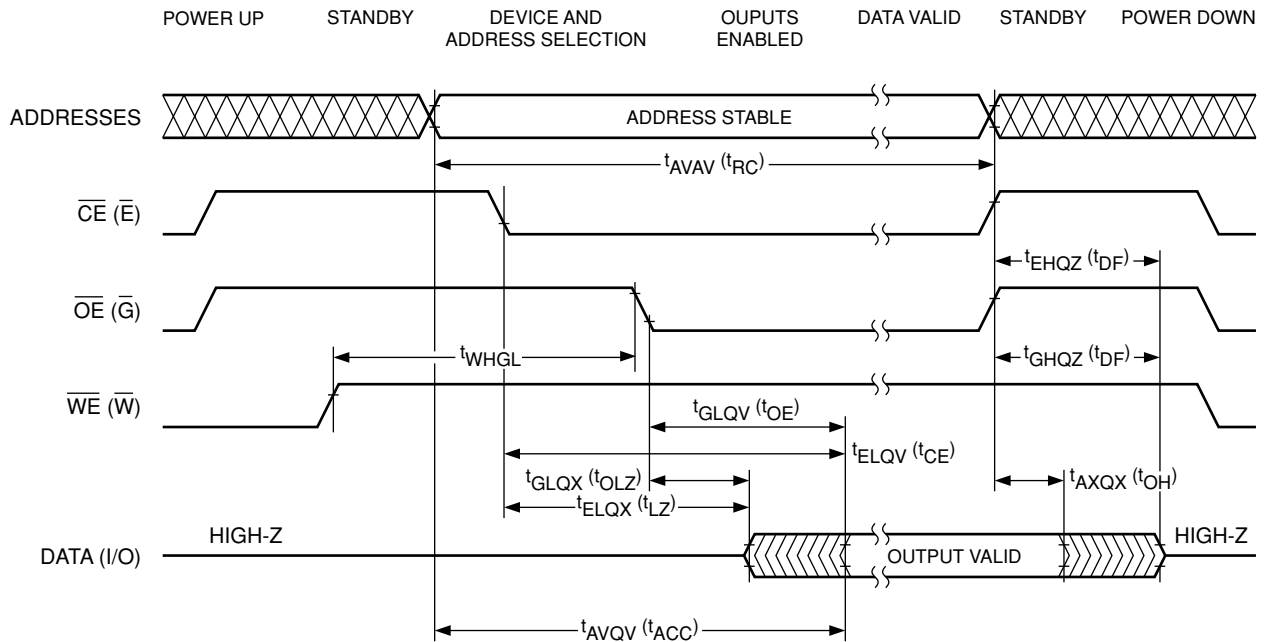

WRITE OPERATIONS

The following operations are initiated by observing the sequence specified in the Write Command Table.

Read Mode

The device can be put into a standard READ mode by initiating a write cycle with 00H on the data bus. The subsequent read cycles will be performed similar to a standard EPROM or E²PROM Read.

Signature Mode

An alternative method for reading device signature (see Read Operations Signature Mode), is initiated by writing the code 90H into the command register while keeping V_{PP} high. A read cycle from address 0000H with \overline{CE} and \overline{OE} low (and \overline{WE} high) will output the device signature.

CATALYST Code = 00110001 (31H)

A Read cycle from address 0001H retrieves the binary code for the device on outputs I/O₀ to I/O₇.

28F020 Code = 1011 1101 (BDH)

Erase Mode

During the first Write cycle, the command 20H is written into the command register. In order to commence the erase operation, the identical command of 20H has to be written again into the register. This two-step process ensures against accidental erasure of the memory contents. The final erase cycle will be stopped at the rising edge of \overline{WE} , at which time the Erase Verify command (A0H) is sent to the command register. During this cycle, the address to be verified is sent to the address bus and latched when \overline{WE} goes low. An integrated stop timer allows for automatic timing control over this operation, eliminating the need for a maximum erase timing specification. Refer to AC Characteristics (Program/Erase) for specific timing parameters.

Figure 4. A.C. Timing for Erase Operation

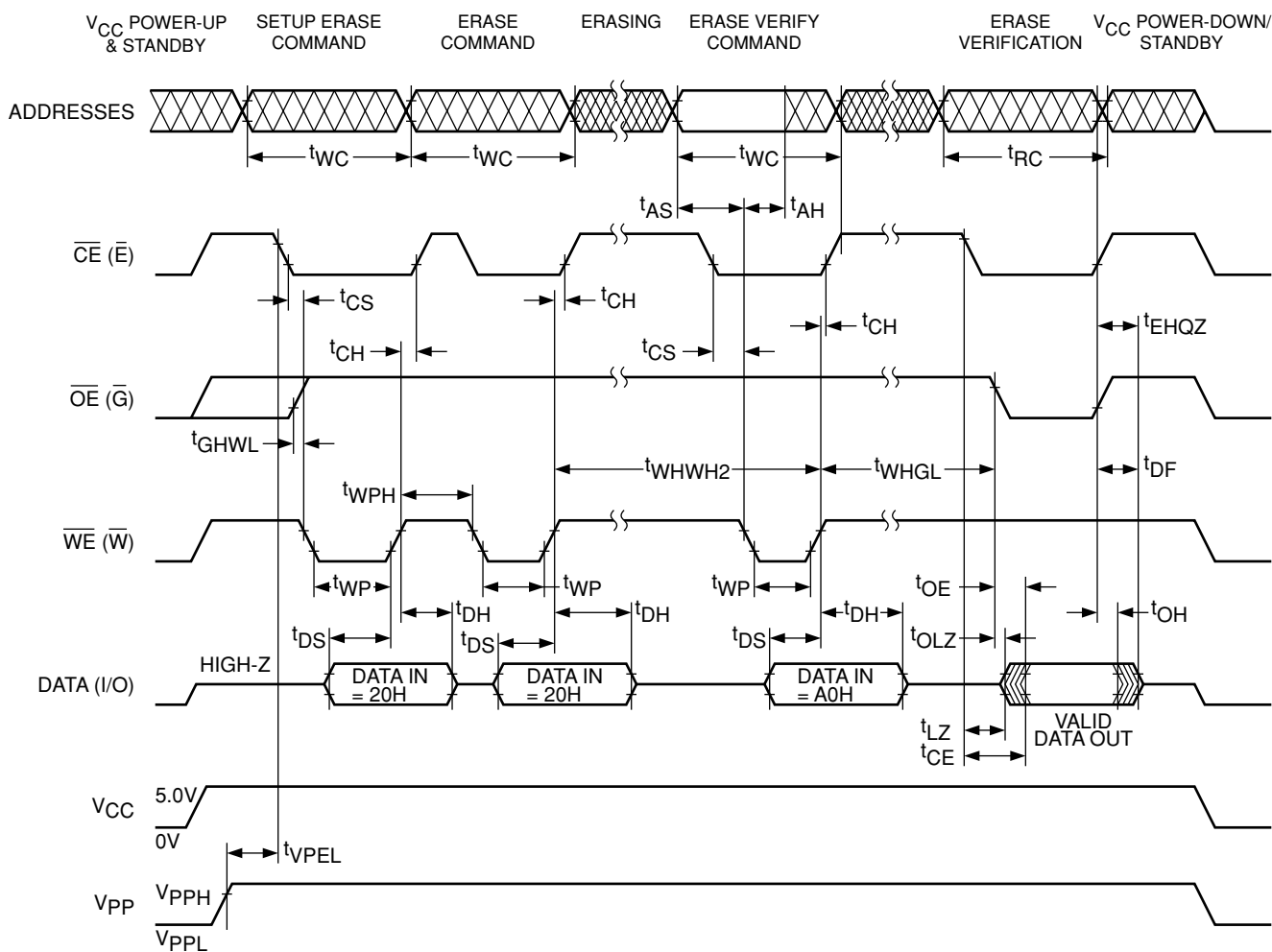
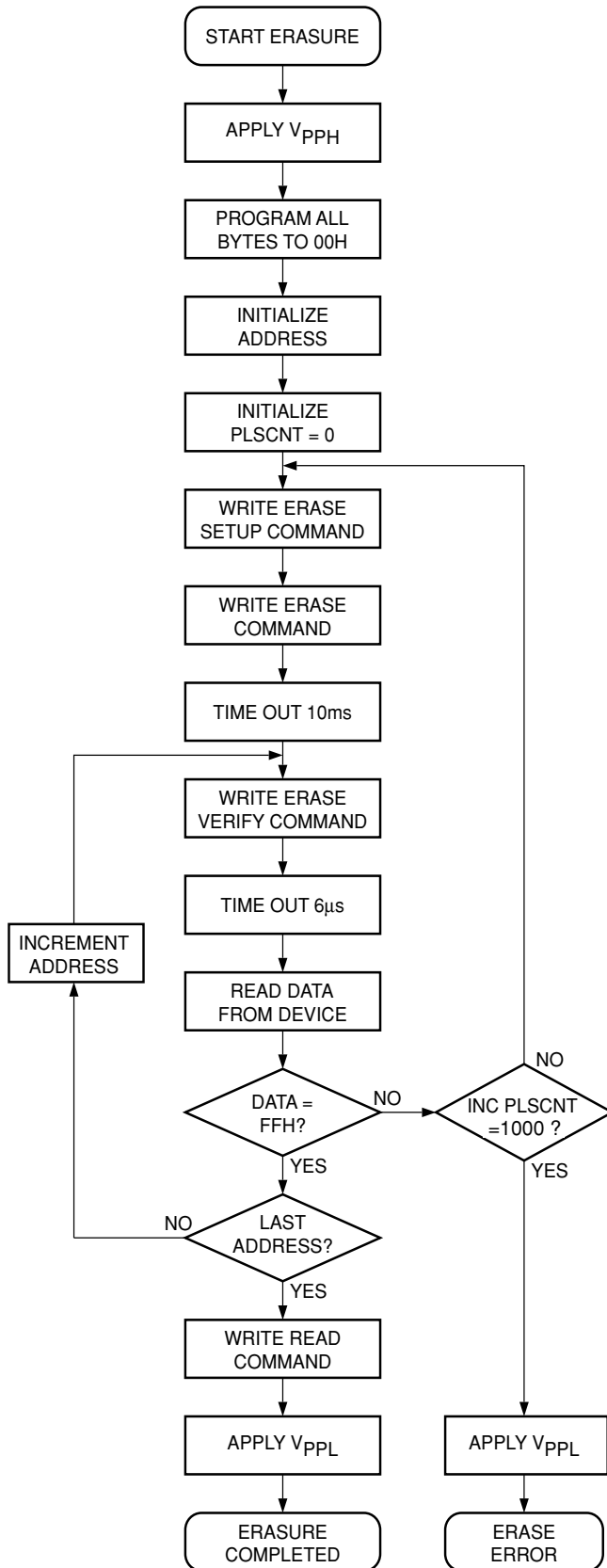

Figure 5. Chip Erase Algorithm⁽¹⁾



BUS OPERATION	COMMAND	COMMENTS
STANDBY		V _{PP} RAMPS TO V _{PPH} (OR V _{PP} HARDWIRED)
STANDBY		ALL BYTES SHALL BE PROGRAMMED TO 00 BEFORE AN ERASE OPERATION
STANDBY		INITIALIZE ADDRESS
STANDBY		PLSCNT = PULSE COUNT
WRITE	ERASE	DATA=20H
WRITE	ERASE	DATA = 20H
STANDBY		WAIT
WRITE	ERASE VERIFY	ADDRESS = BYTE TO VERIFY DATA = A0H STOPS ERASE OPERATION
STANDBY		WAIT
READ		READ BYTE TO VERIFY ERASURE
STANDBY		COMPARE OUTPUT TO FF INCREMENT PULSE COUNT
WRITE	READ	DATA = 00H RESETS THE REGISTER FOR READ OPERATION
STANDBY		V _{PP} RAMPS TO V _{PPH} (OR V _{PP} HARDWIRED)

Note:

(1) The algorithm MUST BE FOLLOWED to ensure proper and reliable operation of the device.

Erase-Verify Mode

The Erase-verify operation is performed on every byte after each erase pulse to verify that the bits have been erased.

Programming Mode

The programming operation is initiated using the programming algorithm of Figure 7. During the first write cycle, the command 40H is written into the command register. During the second write cycle, the address of the memory location to be programmed is latched on the falling edge of \overline{WE} , while the data is latched on the rising edge of \overline{WE} . The program operation terminates with the next rising edge of \overline{WE} . An integrated stop timer allows for automatic timing control over this operation, eliminating the need for a maximum program timing specification. Refer to AC Characteristics (Program/Erase) for specific timing parameters.

Program-Verify Mode

A Program-verify cycle is performed to ensure that all bits have been correctly programmed following each byte programming operation. The specific address is already latched from the write cycle just completed, and stays latched until the verify is completed. The Program-verify operation is initiated by writing C0H into the command register. An internal reference generates the necessary high voltages so that the user does not need to modify V_{CC} . Refer to AC Characteristics (Program/Erase) for specific timing parameters.

Figure 6. A.C. Timing for Programming Operation

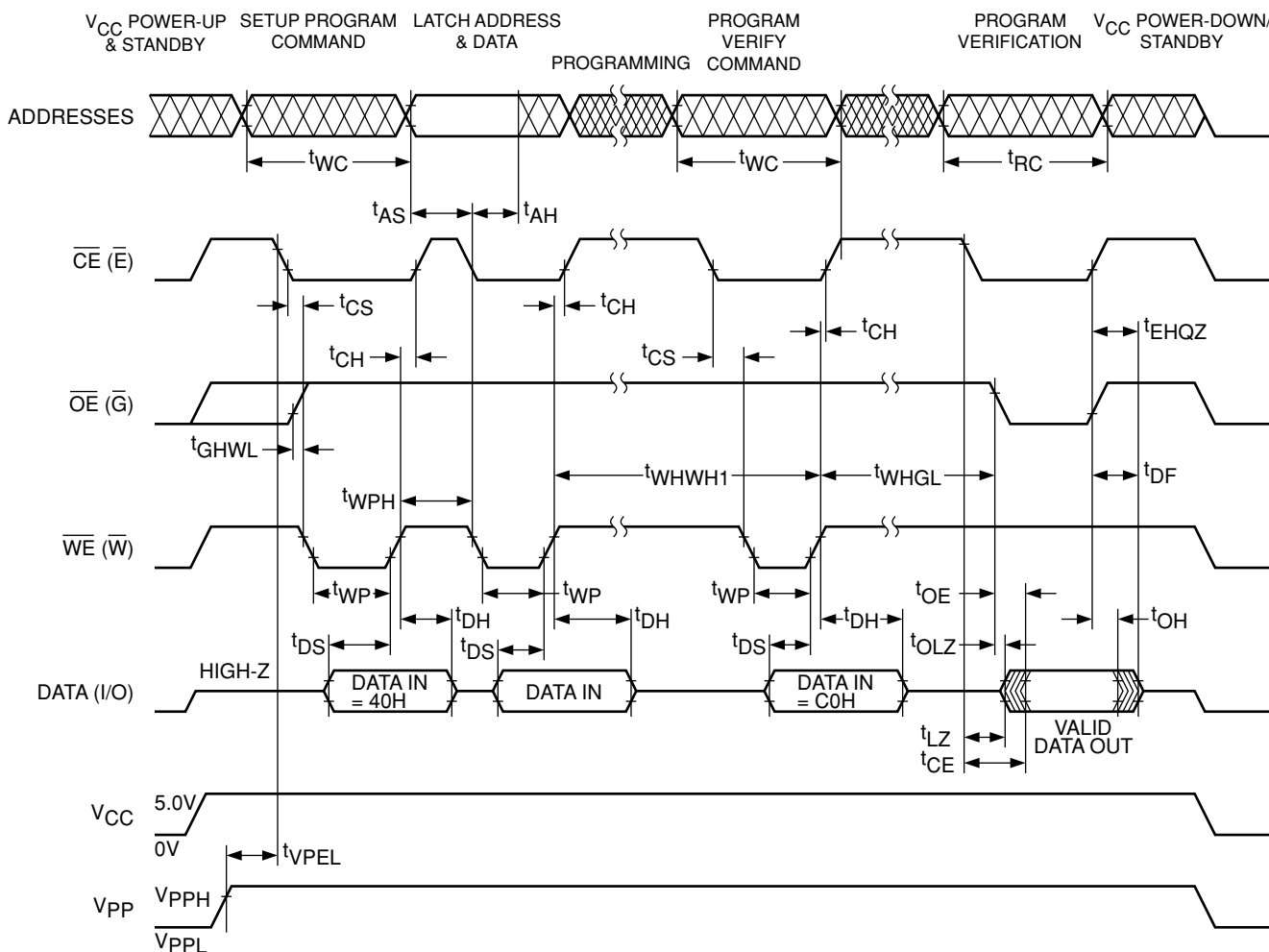
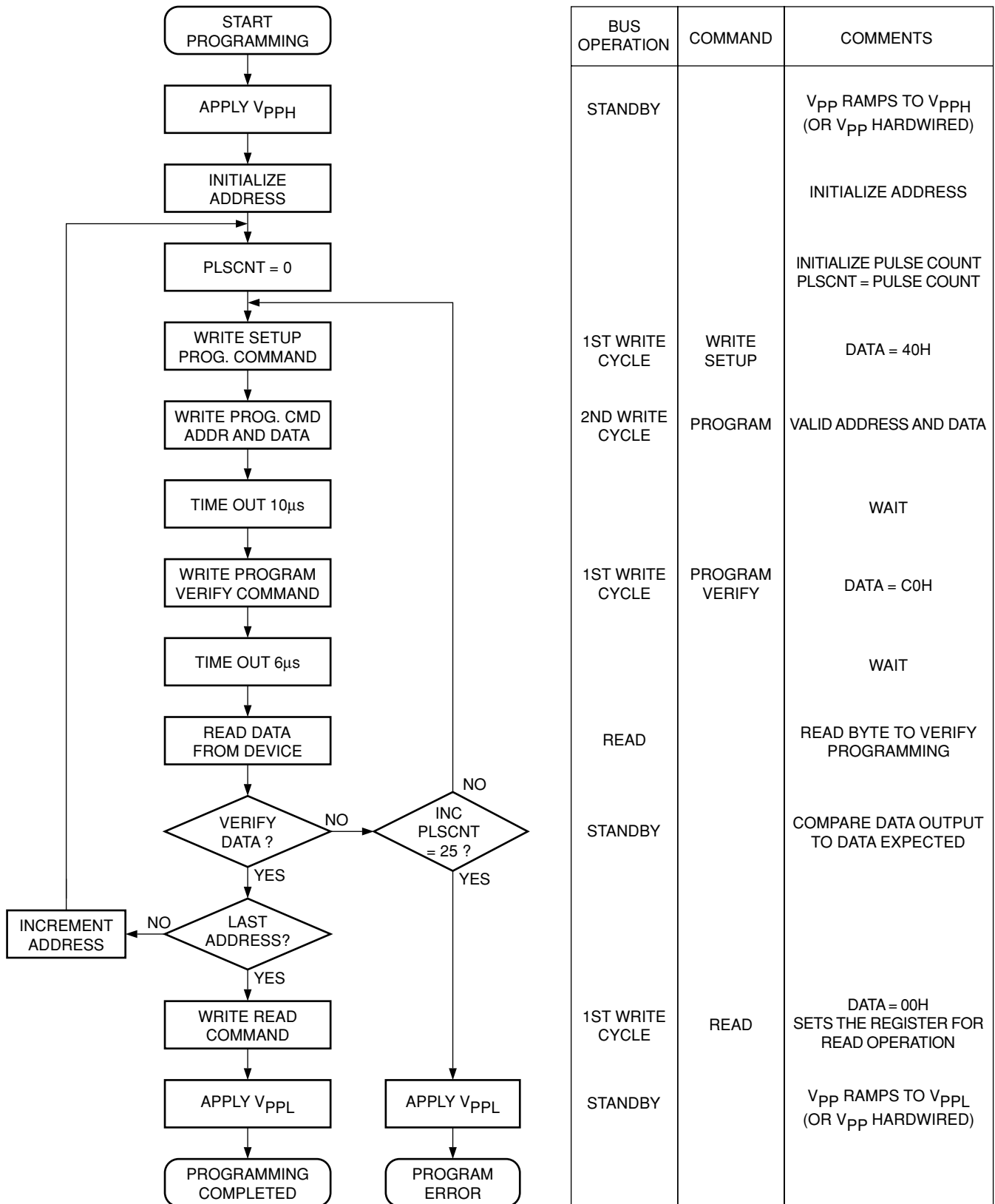

Figure 7. Programming Algorithm⁽¹⁾



Note:

(1) The algorithm MUST BE FOLLOWED to ensure proper and reliable operation of the device.

Abort/Reset

An Abort/Reset command is available to allow the user to safely abort an erase or program sequence. Two consecutive program cycles with FFH on the data bus will abort an erase or a program operation. The abort/reset operation can interrupt at any time in a program or erase operation and the device is reset to the Read Mode.

POWER SUPPLY DECOUPLING

To reduce the effect of transient power supply voltage spikes, it is good practice to use a 0.1μF ceramic capacitor between V_{CC} and V_{SS} and V_{PP} and V_{SS}. These high-frequency capacitors should be placed as close as possible to the device for optimum decoupling.

POWER UP/DOWN PROTECTION

The CAT28F020 offers protection against inadvertent programming during V_{PP} and V_{CC} power transitions. When powering up the device there is no power-on sequencing necessary. In other words, V_{PP} and V_{CC} may power up in any order. Additionally V_{PP} may be hardwired to V_{PPH} independent of the state of V_{CC} and any power up/down cycling. The internal command register of the CAT28F020 is reset to the Read Mode on power up.

Figure 8. Alternate A.C. Timing for Program Operation

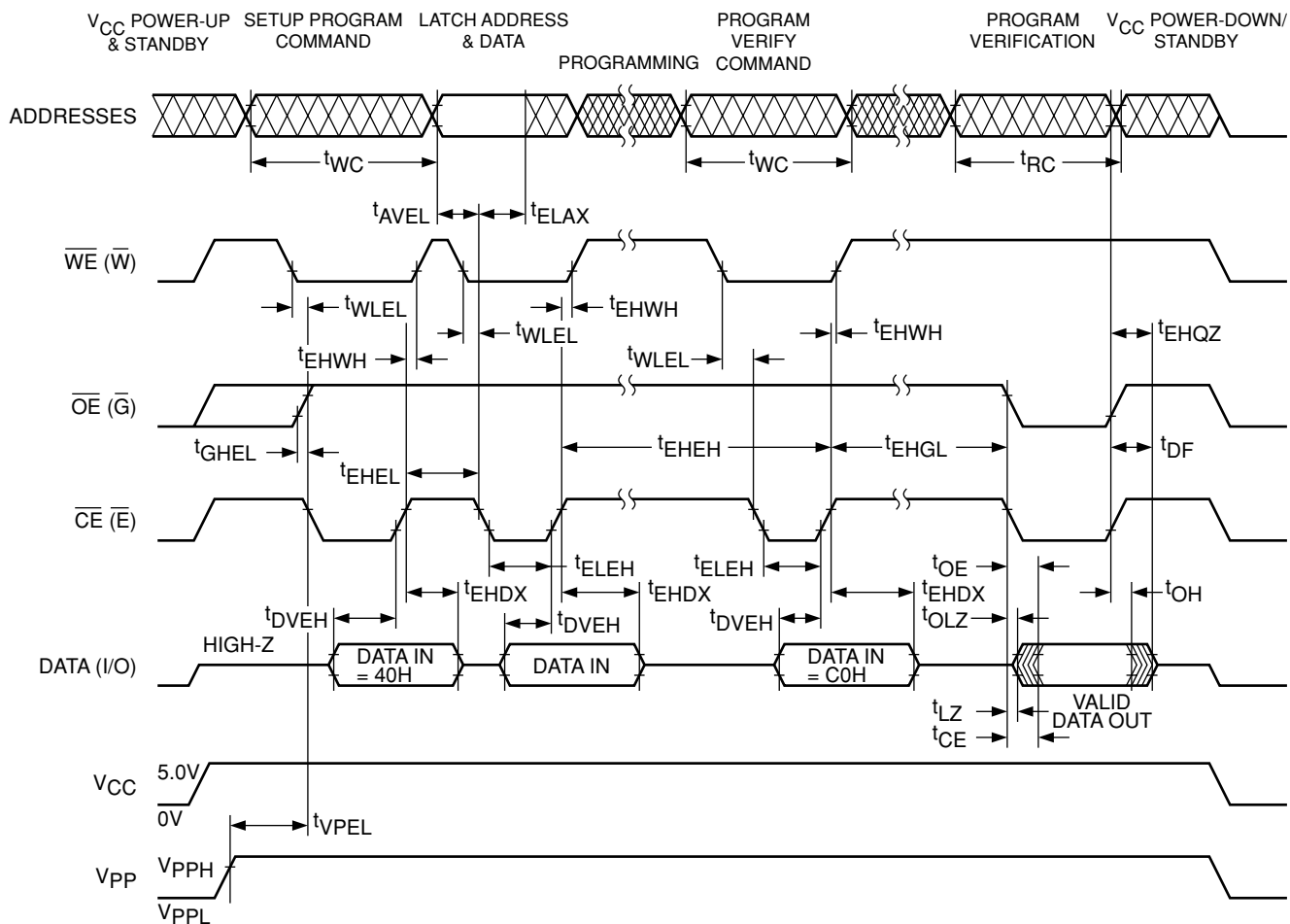

CAT28F020

ALTERNATE \overline{CE} -CONTROLLED WRITES

JEDEC Symbol	Standard Symbol	Parameter	28F020-90			28F020-12			Unit
			Min	Typ	Max	Min	Typ	Max	
tAVAV	tWC	Write Cycle Time	90			120			ns
tAVEL	tAS	Address Setup Time	0			0			ns
tELAX	tAH	Address Hold Time	40			40			ns
tDVEH	tDS	Data Setup Time	40			40			ns
tEHDX	tDH	Data Hold Time	10			10			ns
tEHGL	—	Write Recovery Time Before Read	6			6			μs
tGHEL	—	Read Recovery Time Before Write	0			0			μs
tWLEL	tWS	\overline{WE} Setup Time Before \overline{CE}	0			0			ns
tEHWH	—	\overline{WE} Hold Time After \overline{CE}	0			0			ns
tELEH	tCP	Write Pulse Width	40			40			ns
tEHEL	tCPH	Write Pulse Width High	20			20			ns
tVPEL	—	V _{PP} Setup Time to \overline{CE} Low	100			100			ns

ORDERING INFORMATION

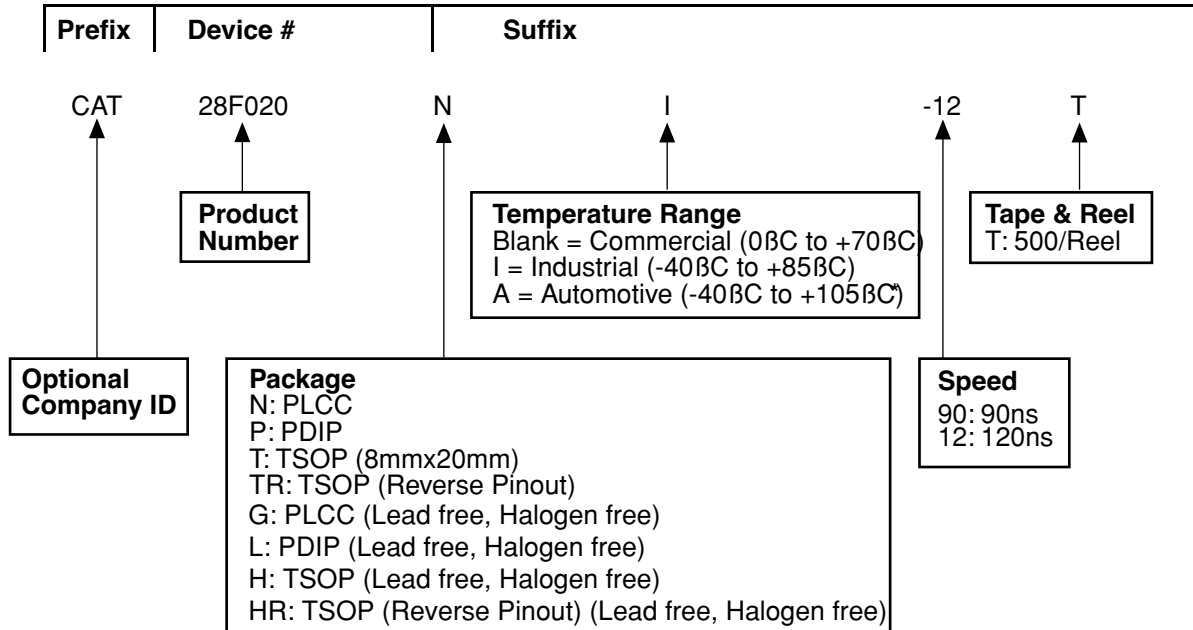

* -40° to +125° is available upon request.

Note:

(1) The device used in the above example is a CAT28F020NI-12T (PLCC, Industrial Temperature, 120 ns access time, Tape & Reel).

REVISION HISTORY

Date	Rev.	Reason
5/1/2002	A	Initial issue
2/10/2004	B	Change V_{CCMIN} for CAT28F020-90 to 4.75 V from 4.5 V
7/1/2004	C	Added Green Packages in all areas.

Copyrights, Trademarks and Patents

Trademarks and registered trademarks of Catalyst Semiconductor include each of the following:

DPP™ AE²™

Catalyst Semiconductor has been issued U.S. and foreign patents and has patent applications pending that protect its products. For a complete list of patents issued to Catalyst Semiconductor contact the Company's corporate office at 408.542.1000.

CATALYST SEMICONDUCTOR MAKES NO WARRANTY, REPRESENTATION OR GUARANTEE, EXPRESS OR IMPLIED, REGARDING THE SUITABILITY OF ITS PRODUCTS FOR ANY PARTICULAR PURPOSE, NOR THAT THE USE OF ITS PRODUCTS WILL NOT INFRINGE ITS INTELLECTUAL PROPERTY RIGHTS OR THE RIGHTS OF THIRD PARTIES WITH RESPECT TO ANY PARTICULAR USE OR APPLICATION AND SPECIFICALLY DISCLAIMS ANY AND ALL LIABILITY ARISING OUT OF ANY SUCH USE OR APPLICATION, INCLUDING BUT NOT LIMITED TO, CONSEQUENTIAL OR INCIDENTAL DAMAGES.

Catalyst Semiconductor products are not designed, intended, or authorized for use as components in systems intended for surgical implant into the body, or other applications intended to support or sustain life, or for any other application in which the failure of the Catalyst Semiconductor product could create a situation where personal injury or death may occur.

Catalyst Semiconductor reserves the right to make changes to or discontinue any product or service described herein without notice. Products with data sheets labeled "Advance Information" or "Preliminary" and other products described herein may not be in production or offered for sale.

Catalyst Semiconductor advises customers to obtain the current version of the relevant product information before placing orders. Circuit diagrams illustrate typical semiconductor applications and may not be complete.



CATALYST

Catalyst Semiconductor, Inc.

Corporate Headquarters

1250 Borregas Avenue

Sunnyvale, CA 94089

Phone: 408.542.1000

Fax: 408.542.1200

www.catalyst-semiconductor.com

Publication #: 1029

Revision: C

Issue date: 7/1/04