



Surface Mount PIN Diodes

Technical Data

HSMP-38XX and HSMP-48XX Series

Features

- **Diodes Optimized for:**
Low Current Switching
Low Distortion Attenuating
Ultra-Low Distortion
Switching
Microwave Frequency
Operation
- **Surface Mount SOT-23 and SOT-143 Packages**
Single and Dual Versions
Tape and Reel Options
Available
- **Low Failure in Time (FIT) Rate⁽¹⁾**

Note:

1. For more information see the Surface Mount PIN Reliability Data Sheet.

Description/Applications

The HSMP-380X and HSMP-381X series are specifically designed for low distortion attenuator applications. The HSMP-382X series is optimized for switching applications where ultra-low resistance is required. The HSMP-3880 switching diode is an ultra low distortion device optimized for higher power applications from 50 MHz to 1.5 GHz. The HSMP-389X series is optimized for switching applications where low resistance at low current and low capacitance are

required. The HSMP-48XX series are special products featuring ultra low parasitic inductance in the SOT-23 package, specifically designed for use at frequencies which are much higher than the upper limit for conventional SOT-23 PIN diodes. The HSMP-4810 diode is a low distortion attenuating PIN designed for operation to 3 GHz. The HSMP-4820 diode is ideal for limiting and low inductance switching applications up to 1.5 GHz. The HSMP-4890 is optimized for low current switching applications up to 3 GHz.

The HSMP-386X series of general purpose PIN diodes are designed for two classes of applications. The first is attenuators where current consumption is the most important design consideration. The second application for this series of diodes is in switches where low cost is the driving issue for the designer.

The HSMP-386X series Total Capacitance (C_T) and Total Resistance (R_T) are typical specifications. For applications that require guaranteed performance, the general purpose HSMP-383X series is recommended. For low distortion

Package Lead Code Identification

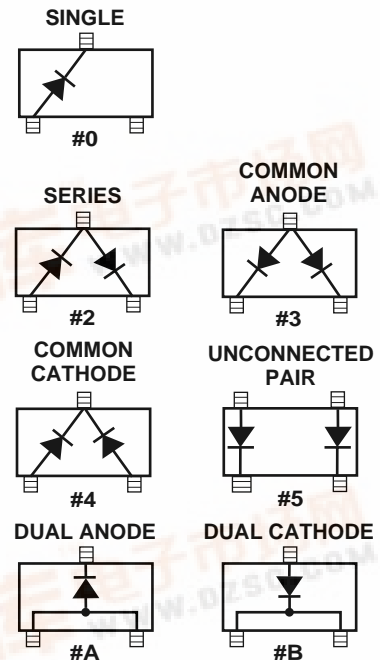

attenuators, the HSMP-380X or -381X series are recommended. For high performance switching applications, the HSMP-389X series is recommended.

A SPICE model is not available for PIN diodes as SPICE does not provide for a key PIN diode characteristic, carrier lifetime.



Absolute Maximum Ratings^[1] $T_A = 25^\circ\text{C}$

Symbol	Parameter	Units	Absolute Maximum
I_f	Forward Current (1 ms Pulse)	Amp	1
P_t	Total Device Dissipation	mW ^[2]	250
P_{iv}	Peak Inverse Voltage	—	Same as V_{BR}
T_j	Junction Temperature	$^\circ\text{C}$	150
T_{STG}	Storage Temperature	$^\circ\text{C}$	-65 to 150

Notes:

- Operation in excess of any one of these conditions may result in permanent damage to this device.
- CW Power Dissipation at $T_{LEAD} = 25^\circ\text{C}$. Derate to zero at maximum rated temperature.

PIN Attenuator Diodes

Electrical Specifications $T_A = 25^\circ\text{C}$ (Each Diode)

Part Number HSMP-	Package Marking Code ^[1]	Lead Code	Configuration	Nearest Equivalent Axial Lead Part No. 5082-	Minimum Breakdown Voltage V_{BR} (V)	Maximum Series Resistance R_S (Ω)	Maximum Total Capacitance C_T (pF)	Minimum High Resistance R_H (Ω)	Maximum Low Resistance R_L (Ω)
3800	D0	0	Single	3080	100	2.0	0.37	1000	8
3802	D2	2	Series						
3804	D4	4	Common Cathode						
3810	E0	0	Single	3081	100	3.0	0.35	1500	10
3812	E2	2	Series						
3813	E3	3	Common Anode						
3814	E4	4	Common Cathode						
Test Conditions					$V_R = V_{BR}$ Measure $I_R \leq 10 \mu\text{A}$	$I_F = 100 \text{ mA}$ $f = 100 \text{ MHz}$	$V_R = 50 \text{ V}$ $f = 1 \text{ MHz}$	$I_F = 0.01 \text{ mA}$ $f = 100 \text{ MHz}$	$I_F = 20 \text{ mA}$ $f = 100 \text{ MHz}$

PIN Switching Diodes

Electrical Specifications $T_A = 25^\circ\text{C}$

Part Number HSMP-	Package Marking Code ^[1]	Lead Code	Configuration	Nearest Equivalent Axial Lead Part No. 5082-	Minimum Breakdown Voltage V_{BR} (V)	Maximum Series Resistance R_S (Ω)	Maximum Total Capacitance C_T (pF)	Maximum Shunt Mode Harmonic Distortion Hmd (dBc)
3820	F0	0	Single	3188	50	0.6*	0.8*	—
3822	F2	2	Series					
3823	F3	3	Common Anode					
3824	F4	4	Common Cathode					
3880	S0	0	Single	—	100	6.5	0.40	-55
3890	G0	0	Single	—	100	2.5	0.30**	—
3892	G2	2	Series					
3893	G3	3	Common Anode					
3894	G4	4	Common Cathode					
3895	G5	5	Unconnected Pair					
Test Conditions					$V_R = V_{BR}$ Measure $I_R \leq 10 \mu\text{A}$	$I_F = 5 \text{ mA}$ $f = 100 \text{ MHz}$ $I_F = 10 \text{ mA}^*$	$V_R = 50 \text{ V}$ $f = 1 \text{ MHz}$ $V_R = 20 \text{ V}^*$ $V_R = 5 \text{ V}^{**}$	$2 f_o, Z_o = 50 \text{ W}$ $f_o = 400 \text{ MHz}$ $P_{in} = +30 \text{ dBm}$ 0 V bias

Note:

- Package marking code is white.

PIN General Purpose Diodes, Electrical Specifications $T_A = 25^\circ\text{C}$

Part Number HSMP-	Package Marking Code ^[1]	Lead Code	Configuration	Nearest Equivalent Axial Lead Part No. 5082-	Minimum Breakdown Voltage V_{BR} (V)	Maximum Series Resistance R_S (Ω)	Maximum Total Capacitance C_T (pF)
3830	K0	0	Single	3077	200	1.5	0.3
3832	K2	2	Series				
3833	K3	3	Common Anode				
3834	K4	4	Common Cathode				
Test Conditions					$V_R = V_{BR}$ Measure $I_R \leq 10$ mA	$I_F = 100$ mA $f = 100$ MHz	$V_R = 50$ V $f = 1$ MHz

High Frequency (Low Inductance, 500 MHz – 3 GHz) PIN Diodes, Electrical Specifications $T_A = 25^\circ\text{C}$

Part Number HSMP-	Package Marking Code	Lead Code	Configuration	Minimum Breakdown Voltage V_{BR} (V)	Maximum Series Resistance R_S (Ω)	Typical Total Capacitance C_T (pF)	Maximum Total Capacitance C_T (pF)	Typical Total Inductance L_T (nH)	Application
4810	EB	B	Dual Cathode	100	3.0	0.35	0.4	1.0	Attenuator
4820	FA	A	Dual Anode	50	0.6*	0.75*	1.0	1.0*	Limiter
4890	GA	A	Dual Anode	100	2.5**	0.33	0.375	1.0	Switch
				$V_R = V_{BR}$ Measure $I_R \leq 10$ μA	$I_F = 100$ mA $I_F = 10$ mA* $I_F = 5$ mA**	$V_R = 50$ V $f = 1$ MHz $V_R = 20$ V*	$V_R = 50$ V $f = 1$ MHz $V_R = 0$ V	$f = 500$ MHz – 3 GHz $V_R = 20$ V*	

PIN General Purpose Diodes, Typical Specifications $T_A = 25^\circ\text{C}$

Part Number HSMP-	Code Marking Code ^[1]	Lead Code	Configuration	Minimum Breakdown Voltage V_{BR} (V)	Typical Series Resistance R_S (Ω)	Typical Total Capacitance C_T (pF)
3860	L0	0	Single	50	3.0/1.5*	0.20
3862	L2	2	Series			
3863	L3	3	Common Anode			
3864	L4	4	Common Cathode			
Test Conditions				$V_R = V_{BR}$ Measure $I_R \leq 10$ μA	$I_F = 10$ mA $f = 100$ MHz * $I_F = 100$ mA	$V_R = 50$ V $f = 1$ MHz

Typical Parameters at $T_A = 25^\circ\text{C}$

Part Number HSMP-	Series Resistance R_S (Ω)	Carrier Lifetime τ (ns)	Reverse Recovery Time T_{rr} (ns)	Total Capacitance C_T (pF)
380X	55	1800	500	0.32 @ 50 V
381X	75	1500	300	0.27 @ 50 V
382X	1.5	70*	7	0.60 @ 20 V
383X	20	500	80	0.20 @ 50 V
388X	3.8	2500	550	0.30 @ 50 V
389X	3.8	200*	-	0.20 @ 5 V
Test Conditions		$I_F = 50$ mA $I_R = 250$ mA $I_F = 10$ mA* $I_R = 6$ mA*	$V_R = 10$ V $I_F = 20$ mA 90% Recovery	

Note:

1. Package marking code is white.

Typical Parameters at $T_A = 25^\circ\text{C}$ (unless otherwise noted), Single Diode

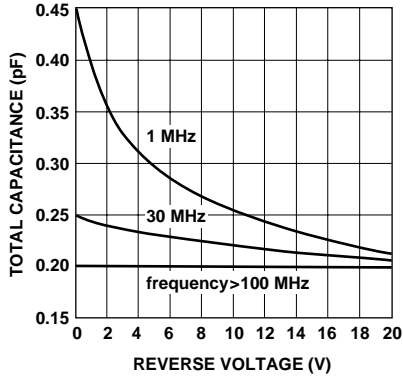

Figure 1. RF Capacitance vs. Reverse Bias, HSMP-3810 Series.

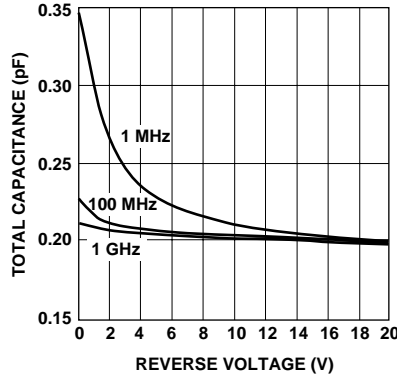

Figure 2. RF Capacitance vs. Reverse Bias, HSMP-3830 Series.

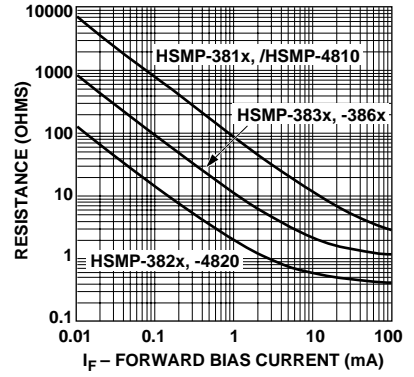

Figure 3. Resistance at 25°C vs. Forward Bias Current.

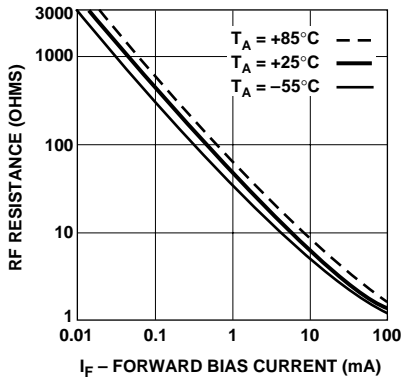

Figure 4. RF Resistance vs. Forward Bias Current for HSMP-3800.

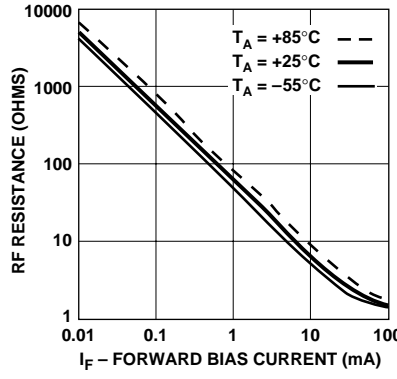

Figure 5. RF Resistance vs. Forward Bias Current for HSMP-3810/HSMP-4810.

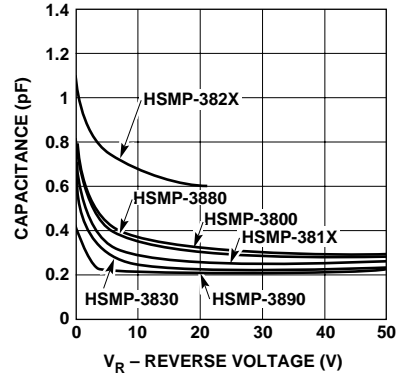

Figure 6. Capacitance vs. Reverse Voltage.

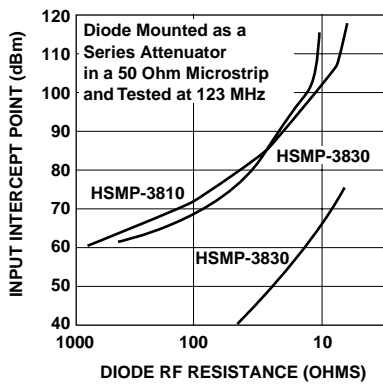

Figure 7. 2nd Harmonic Input Intercept Point vs. Diode RF Resistance for Attenuator Diodes.

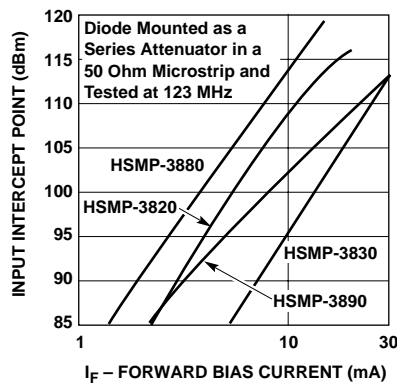

Figure 8. 2nd Harmonic Input Intercept Point vs. Forward Bias Current for Switch Diodes.

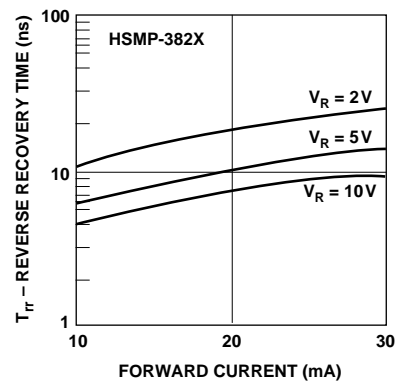

Figure 9. Reverse Recovery Time vs. Forward Current for Various Reverse Voltages, HSMP-3820 Series.

Typical Parameters (continued)

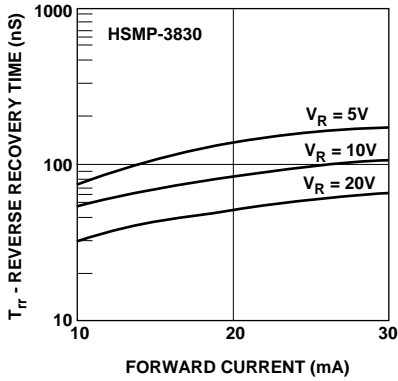

Figure 10. Reverse Recovery Time vs. Forward Current for Various Reverse Voltage. HSMP-3830 Series.

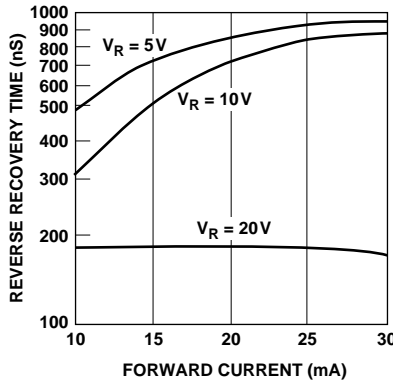

Figure 11. Typical Reverse Recovery Time vs. Reverse Voltage. HSMP-3880 Series.

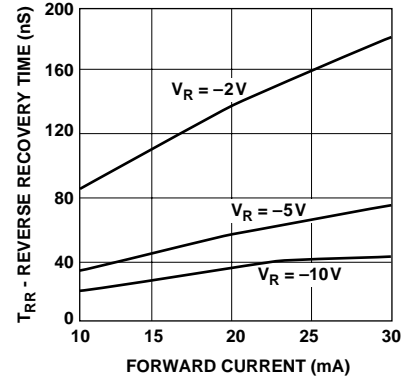

Figure 12. Typical Reverse Recovery Time vs. Reverse Voltage. HSMP-3890 Series.

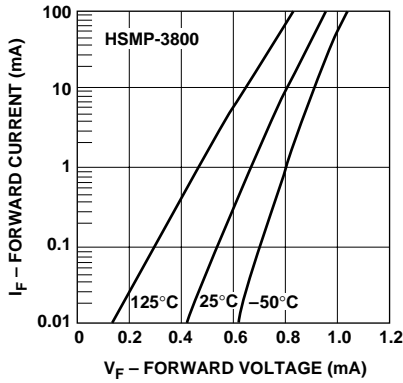

Figure 13. Forward Current vs. Forward Voltage. HSMP-3800 Series.

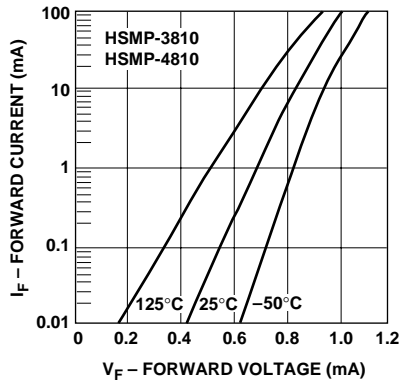

Figure 14. Forward Current vs. Forward Voltage. HSMP-3810 and HSMP-4810 Series.

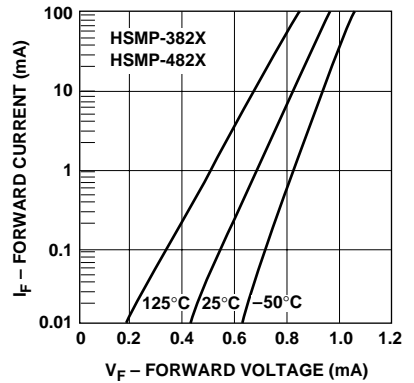

Figure 15. Forward Current vs. Forward Voltage. HSMP-3820 and HSMP-4820 Series.

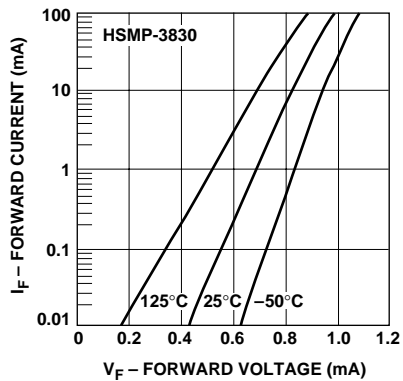

Figure 16. Forward Current vs. Forward Voltage. HSMP-3830 Series.

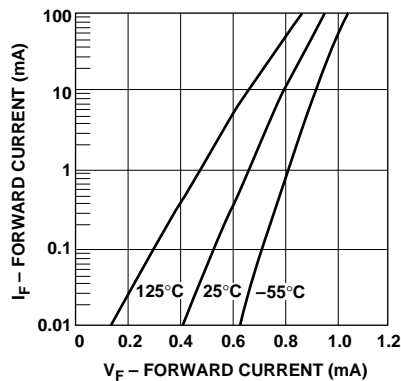

Figure 17. Forward Current vs. Forward Voltage. HSMP-3880 Series.

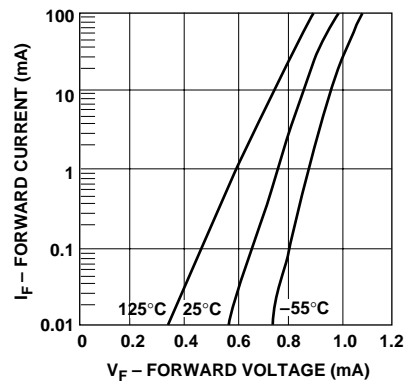

Figure 18. Forward Current vs. Forward Voltage. HSMP-3890 and HSMP-4890 Series.

Typical Parameters (continued)

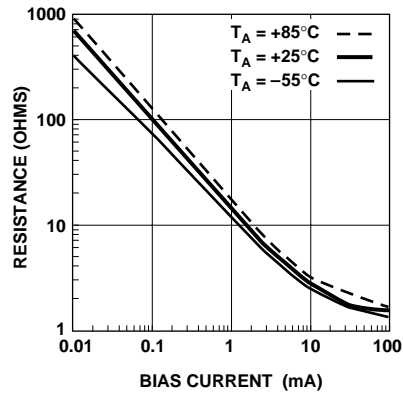

Figure 19. Typical RF Resistance vs. Forward Bias Current for HSMP-3860.

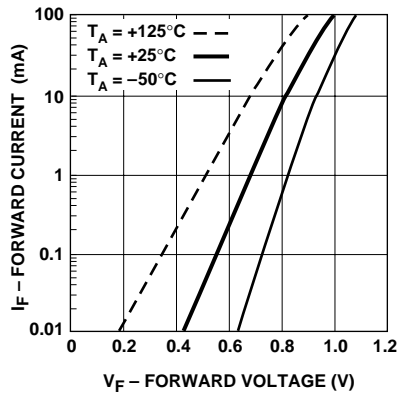

Figure 20. Forward Current vs. Forward Voltage for HSMP-3860.

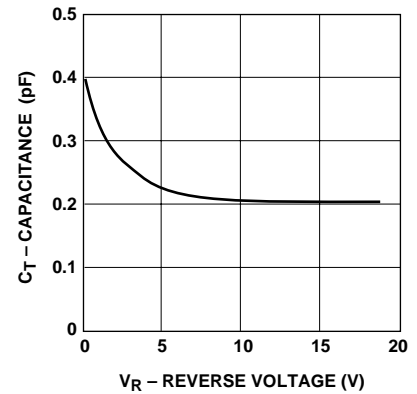
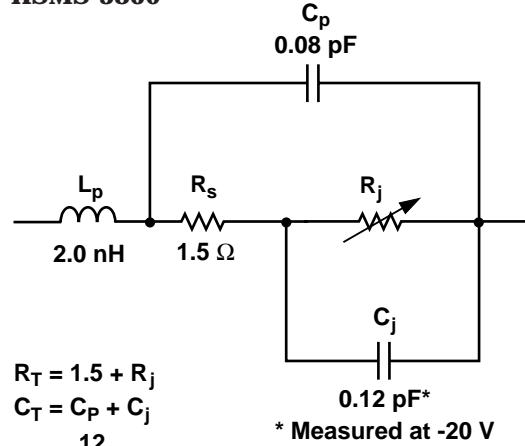

Figure 21. Typical Capacitance vs. Reverse Bias for HSMP-3860.

Equivalent Circuit Model HSMS-3860



$$R_T = 1.5 + R_j$$

$$C_T = C_p + C_j$$

$$R_j = \frac{12}{I^{0.9}} \Omega$$

I = Forward Bias Current in mA

Typical Applications for Multiple Diode Products

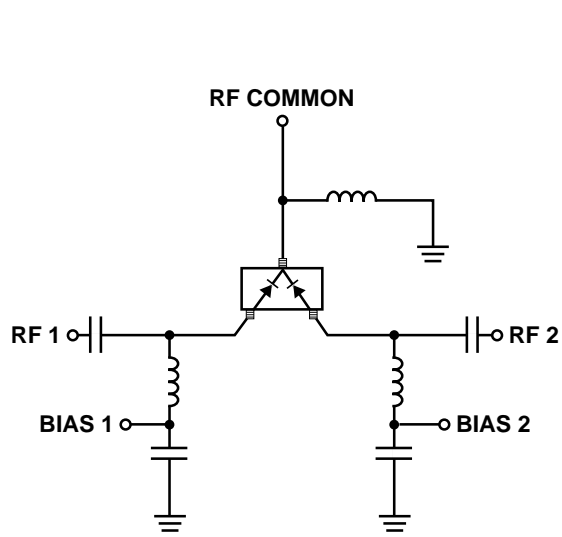

Figure 22. Simple SPDT Switch, Using Only Positive Current.

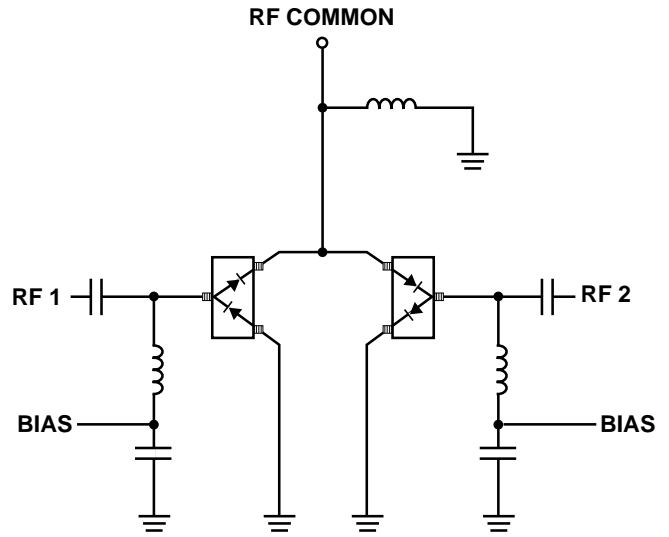

Figure 23. High Isolation SPDT Switch, Dual Bias.

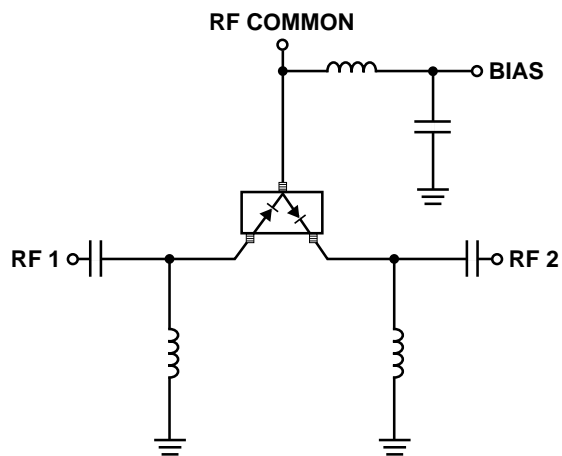

Figure 24. Switch Using Both Positive and Negative Bias Current.

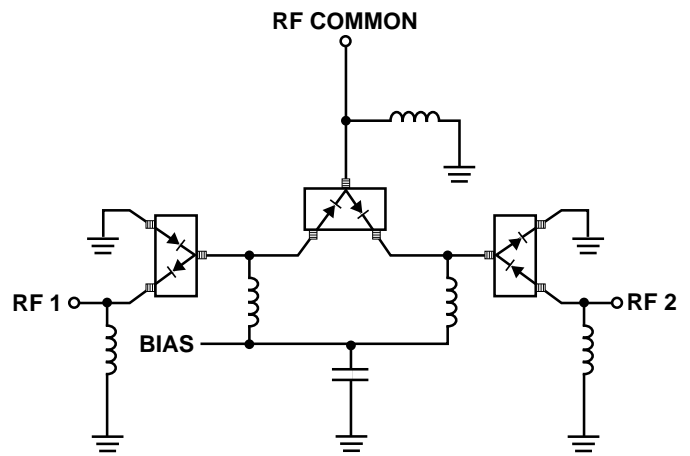

Figure 25. Very High Isolation SPDT Switch, Dual Bias.

Typical Applications for Multiple Diode Products (continued)

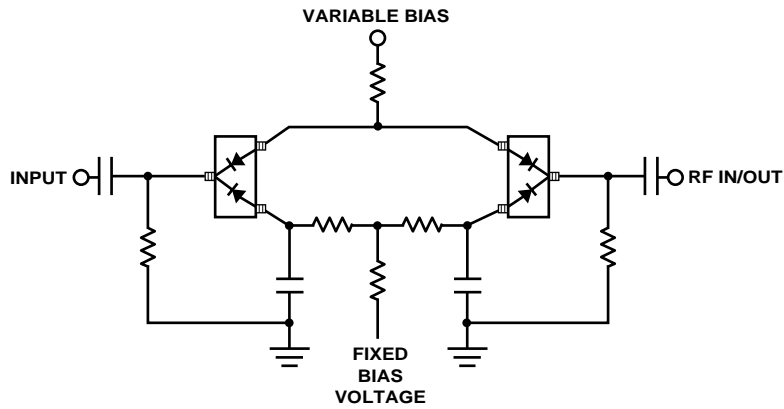
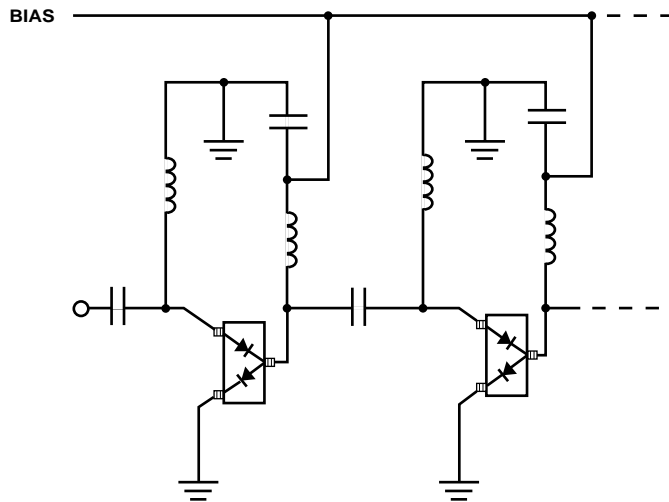
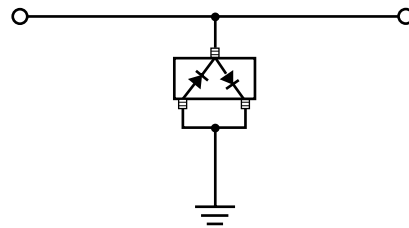

Figure 26. Four Diode π Attenuator.



**Figure 27. High Isolation SPST Switch
(Repeat Cells as Required).**



**Figure 28. Power Limiter Using HSMP-3822
Diode Pair.**

Typical Applications for HSMP-48XX Low Inductance Series



Figure 29. Internal Connections.

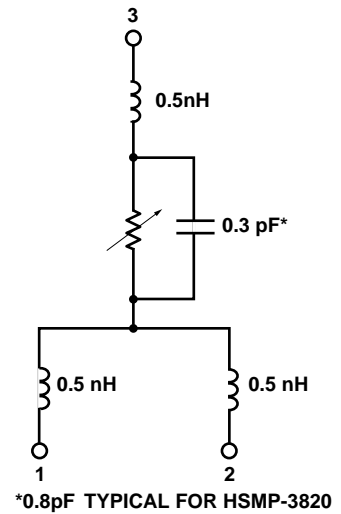

Figure 30. Equivalent Circuit.

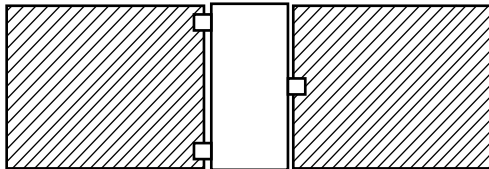

Figure 31. Circuit Layout.

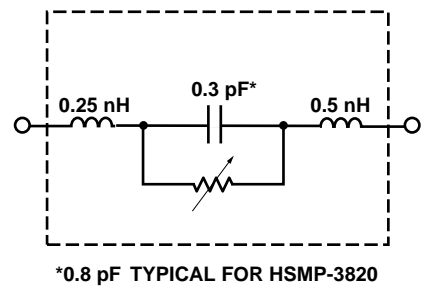

Figure 32. Equivalent Circuit.

Microstrip Series Connection for HSMP-48XX Series

In order to take full advantage of the low inductance of the HSMP-48XX series when using them in series application, both lead 1 and lead 2 should be connected together, as shown above.

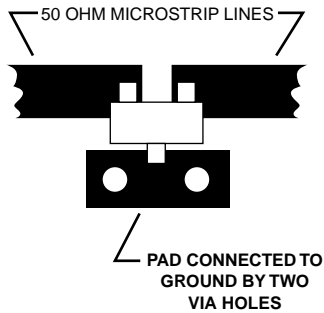

Figure 33. Circuit Layout.

Microstrip Shunt Connections for HSMP-48XX Series

In the diagram above, the center conductor of the microstrip line is interrupted and leads 1 and 2 of the

HSMP-38XX series diode are placed across the resulting gap. This forces the 0.5 nH lead inductance of leads 1 and 2 to appear as part of a low pass filter, reducing the shunt parasitic inductance and

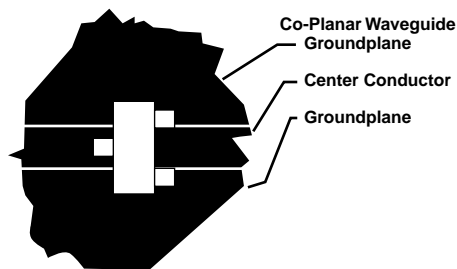
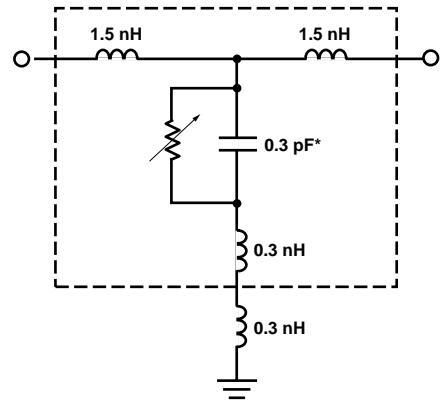

Figure 35. Circuit Layout.

Co-Planar Waveguide Shunt Connection for HSMP-48XX Series

Co-Planar waveguide, with ground on the top side of the printed circuit board, is shown

in the diagram above. Since it eliminates the need for via holes to ground, it offers lower shunt parasitic inductance and higher maximum attenuation when compared to a microstrip circuit.



*0.8 pF TYPICAL FOR HSMP-4820

Figure 34. Equivalent Circuit.

increasing the maximum available attenuation. The 0.3 nH of shunt inductance external to the diode is created by the via holes, and is a good estimate for 0.032" thick material.

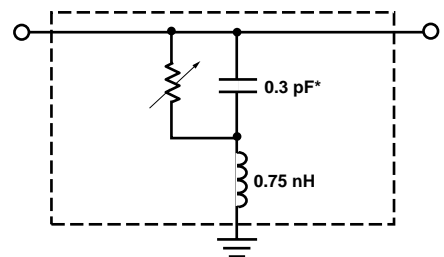

*0.8 pF TYPICAL FOR HSMP-4820

Figure 36. Equivalent Circuit.

Package Dimensions Outline 23 (SOT-23)

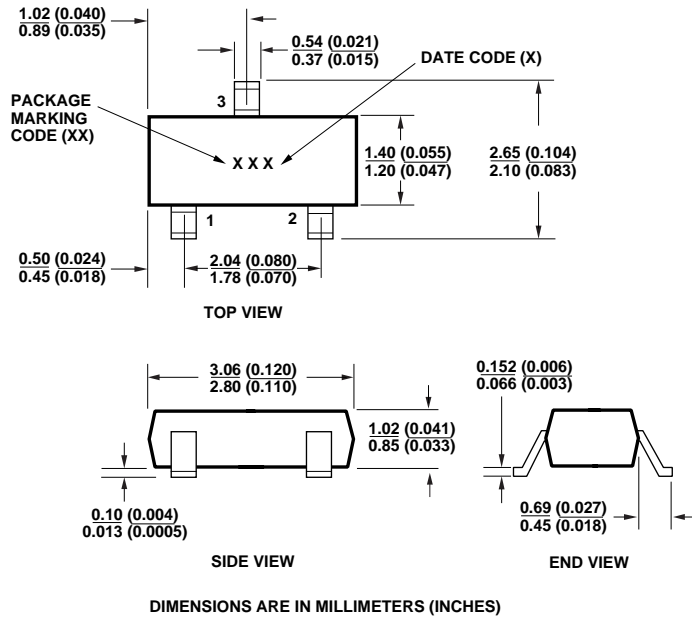

PC Board Footprints SOT-23

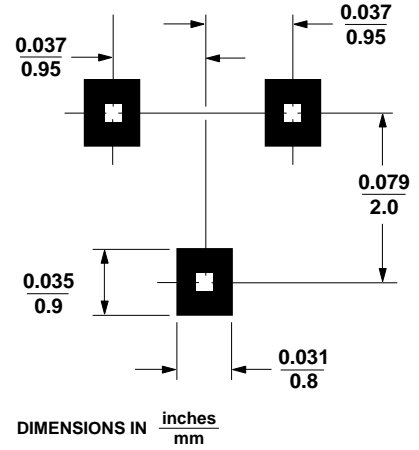

Outline 143 (SOT-143)

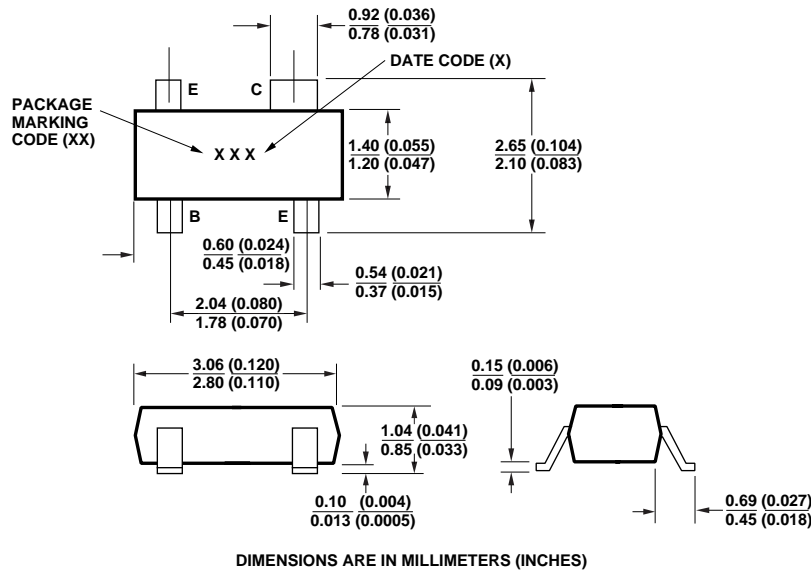

SOT-143

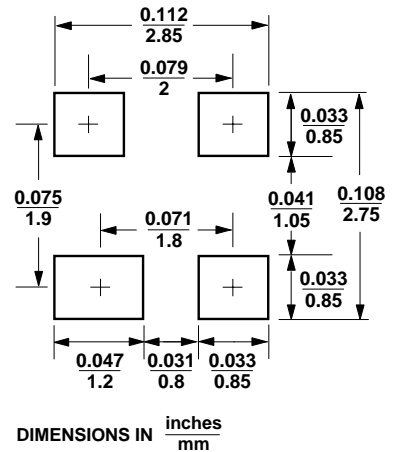

Package Characteristics

- Lead Material Alloy 42
- Lead Finish Tin-Lead 85-15%
- Maximum Soldering Temperature 260°C for 5 seconds
- Minimum Lead Strength 2 pounds pull
- Typical Package Inductance 2 nH
- Typical Package Capacitance 0.08 pF (opposite leads)

Profile Option Descriptions

- BLK = Bulk
- TR1 = 3K pc. Tape and Reel, Device Orientation; See Figures 37 and 38
- TR2 = 10K pc. Tape and Reel, Device Orientation; See Figures 37 and 38

Tape and Reeling conforms to Electronic Industries RS-481, "Taping of Surface Mounted Components for Automated Placement."

Ordering Information

Specify part number followed by option under. For example:

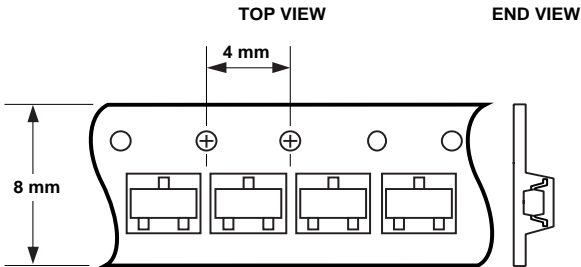
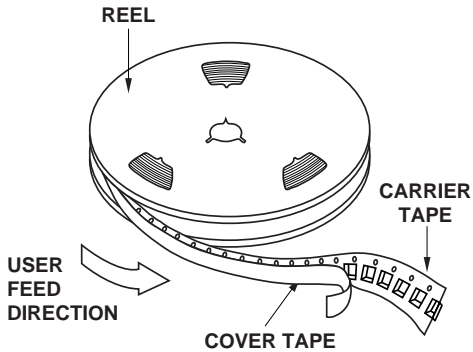
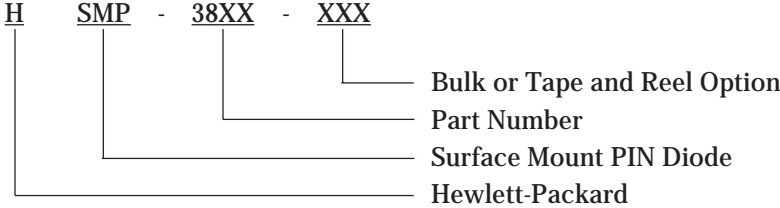

Figure 37. Options -TR1, -TR2 for SOT-23 Packages.

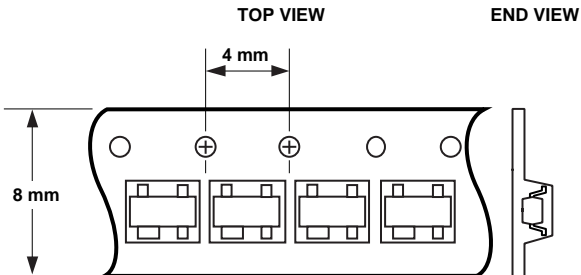

Figure 38. Options -TR1, -TR2 for SOT-143 Packages.

www.hp.com/go/rf

For technical assistance or the location of your nearest Hewlett-Packard sales office, distributor or representative call:

Americas/Canada: 1-800-235-0312 or 408-654-8675

Far East/Australasia: Call your local HP sales office.

Japan: (81 3) 3335-8152

Europe: Call your local HP sales office.

Data subject to change.
Copyright © 1999 Hewlett-Packard Co.

Obsoletes 5968-3435E 5968-5439E (6/99)