

19-0014; Rev 2; 7/96

MAXIM

High-Voltage, Fault-Protected Analog Multiplexers

MAX388/MAX389

General Description

The MAX388 8-channel single-ended (1-of-8) and the MAX389 4-channel differential (2-of-8) multiplexers (muxes) with internal data latches use a high-voltage series N-channel, P-channel, N-channel structure that significantly improves fault protection over previous devices. If power is removed with input voltages still applied, all channels turn off, allowing only a few nanoamperes of input leakage current. This protects the mux and output circuitry, as well as the signal sources connected to the channel inputs.

When an overvoltage signal up to $\pm 100V$ (typically $\pm 110V$) is applied to an analog input or output, the channel turns off. To further protect output circuitry from on-channel overvoltage, outputs are clamped to less than the power-supply voltage. Since there is no increase in supply current during fault conditions, power dissipation does not increase. The MAX388/MAX389 withstand full overvoltage on any combination of channels, including all channels simultaneously.

All channel selection and control inputs are TTL and CMOS compatible. And, break-before-make switch operation is guaranteed.

Applications

- Data-Acquisition Systems
- Industrial Process Control Systems
- Avionics Test Equipment
- Signal Routing Between Systems
- Computer-Controlled Analog Data Logging

Typical Operating Circuit

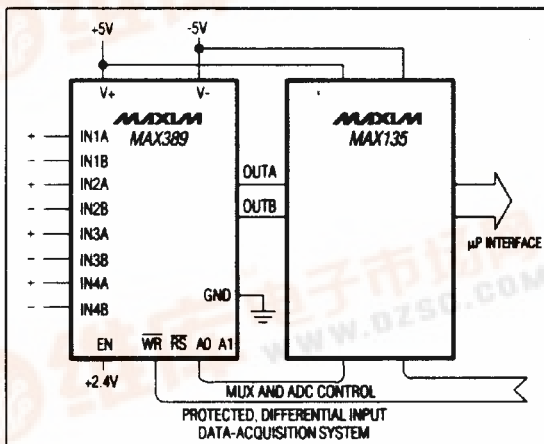

Features

- ◆ Fault and Overvoltage Protection
- ◆ Fail-Safe with Power Loss (No Latchup)
- ◆ Break-Before-Make Switching
- ◆ All Channels Off when Power Off
- ◆ Internal Data Latches
- ◆ TTL and CMOS Compatible
- ◆ Operates from $\pm 4.5V$ to $\pm 18V$ Supplies
- ◆ On-Channels Turn Off during Overvoltage
- ◆ Nanoamperes Leakage in Overvoltage

Ordering Information

PART	TEMP. RANGE	PIN-PACKAGE
MAX388CPN	0°C to +70°C	18 Plastic DIP
MAX388CJN	0°C to +70°C	18 CERDIP
MAX388CWG	0°C to +70°C	24 SO
MAX388C/D	0°C to +70°C	Dice*
MAX388EPN	-40°C to +85°C	18 Plastic DIP
MAX388EJN	-40°C to +85°C	18 CERDIP
MAX388EWG	-40°C to +85°C	24 SO
MAX388MJN	-55°C to +125°C	18 CERDIP**

Ordering information continued on last page.

*Contact factory for dice specifications.

**Contact factory for availability and processing to MIL-STD1 883.

Pin Configurations

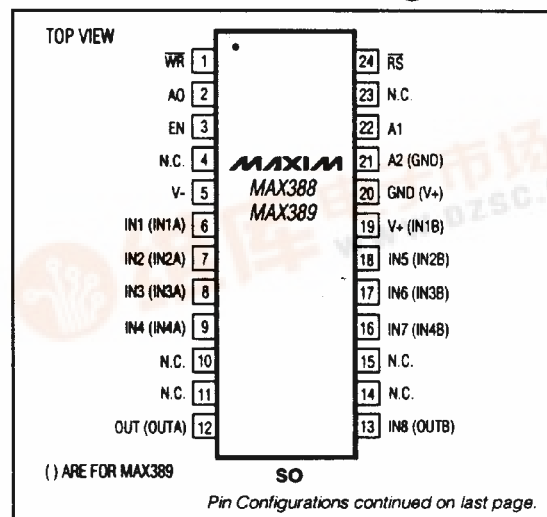

MAXIM

Maxim Integrated Products 1

For free samples & the latest literature: <http://www.maxim-ic.com>, or phone 1-800-998-8800



High-Voltage, Fault-Protected Analog Multiplexers

ABSOLUTE MAXIMUM RATINGS

V+ to V-	44V
V+ to GND	22V
V- to GND	-22V
EN, WR, RS, A0-A2	V+ + 4V to V- - 4V
Analog Input with V+ = 15V, V- = -15V	±100V
Analog Input with V+ = V- = 0V	±115V
Continuous Current, IN or OUT	20mA
Peak Current, IN or OUT (Note 1)	40mA

Continuous Power Dissipation	
24-Pin SO (derate 11.76mW/°C above +70°C)	941mW
18-Pin Plastic DIP (derate 11.1mW/°C above +70°C)	869mW
18-Pin CERDIP (derate 10.53mW/°C above +70°C)	842mW
Operating Temperature Ranges	
MAX38_C_	0°C to +70°C
MAX38_E_	-40°C to +85°C
MAX38_MJN	-55°C to +125°C
Storage Temperature Range	-65°C to +150°C
Lead Temperature (soldering, 10sec)	+300°C

Note 1: Pulsed at 1ms, 10% maximum duty cycle.

Stresses beyond those listed under "Absolute Maximum Ratings" may cause permanent damage to the device. These are stress ratings only, and functional operation of the device at these or any other conditions beyond those indicated in the operational sections of the specifications is not implied. Exposure to absolute maximum rating conditions for extended periods may affect device reliability.

ELECTRICAL CHARACTERISTICS

(V+ = 15V, V- = -15V, GND = WR = 0V, RS = +2.4V, TA = +25°C, unless otherwise noted.)

PARAMETER	SYMBOL	CONDITIONS	C, E SUFFIXES			M SUFFIX			UNITS	
			MIN	TYP	MAX	MIN	TYP	MAX		
Analog Signal Range	VANALOG	(Note 4)	-15		15	-15		15	V	
Drain-Source On Resistance	rDS(ON)	VD = ±10V, VAL = 0.8V IS = 100µA, VAH = 2.4V		2.0	3.0		2.0	3.0	kΩ	
			TMAX	3.0	4.0		3.0	4.0		
Greatest Change in rDS(ON) Between Channels	ΔrDS(ON)	-10V < VS < 10V		10			10		%	
Source-Off Leakage Current (Note 2)	IIN(OFF)	VEN = 0.8V, VIN = ±10V, VOUT = ±10V		0.03	±1.00		0.03	±0.50	nA	
			TMAX		±50		±50			
Drain-Off Leakage Current (Note 2)	IOUT(OFF)	VEN = 0.8V, VIN = ±10V, VOUT = ±10V	MAX388		0.1	±2.0		0.1	±1.0	nA
				TMAX		±200		±200		
			MAX389			±2.0		±1.0		
				TMAX		±100		±100		
Drain-On Leakage Current (Note 2)	IOUT(ON)	VEN = VAH = 2.4V, VOUT = VIN = ±10V, VAL = 0.8V	MAX388				±20	±20	nA	
				TMAX		±600		±1000		
			MAX389			±20		±20		
				TMAX		±300		±600		
LOGIC INPUT										
Logic Input Current (Input Voltage High)	IAH	VA = 2.4V (Note 3)			±1			±1	µA	
		VA = 14V (Note 3)			±1			±1		
Logic Input Current (Input Voltage Low)	IAL	VEN = 0V or 2.4V, VA = RS = WR = 0V			±1			±1	µA	
FAULT										
Output Leakage Current with Overvoltage	IOUT(OFF)	VOUT = 0V, VIN = ±60V, (Note 5)			±0.05			±0.02	µA	
			TMAX		20		10	µA		
Input Leakage Current with Overvoltage	IIN(OFF)	VIN = ±60V VOUT = ±10V, (Note 5)			40			25	µA	
Input Leakage Current with Power Supplies Off	IIN(OFF)	VIN = ±100V, VEN = VOUT = 0V, A0 = A1 = A2 = 0V or 5V			20			10	µA	

High-Voltage, Fault-Protected Analog Multiplexers

MAX388/MAX389

ELECTRICAL CHARACTERISTICS (continued)

(V+ = 15V, V- = -15V, GND = \overline{WR} = 0V, \overline{RS} = +2.4V, T_A = +25°C, unless otherwise noted.)

PARAMETER	SYMBOL	CONDITIONS	C, E SUFFIXES			M SUFFIX			UNITS
			MIN	TYP	MAX	MIN	TYP	MAX	
DYNAMIC									
Multiplexer Switching Time	t _{TRANS}	Figure 2	0.5	1.0		0.5	1.0		μs
Break-Before-Make Interval	t _{OPEN}	Figure 3	0.2			0.2			μs
Enable or Write Turn-On Time	t _{ON(EN)} t _{ON(WR)}	Figures 4 and 5	1.0	1.5		1.0	1.5		μs
Enable or Write Turn-Off Time	t _{OFF(EN)} t _{OFF(WR)}	Figures 4 and 6	0.4	1.0		0.4	1.0		μs
Charge Injection	Q	Figure 7, Tables 1a and 1b	55			55			pC
Off Isolation	OIRR	V _{EN} = 0V, R _L = 1kΩ, C _L = 15pF, V _{IN} = 7V _{RMS} , f = 100kHz	68			68			dB
Logic Input Capacitance with Switch Off	C _{IN}	f = 1MHz	5			5			pF
Input Capacitance with Switch Off	C _{S(OFF)}	V _{EN} = 0V, V _{IN} = 0V, f = 140kHz	5			5			pF
Output Capacitance with Switch Off	C _{D(OFF)}	V _{EN} = 0V, f = 140kHz, V _{OUT} = 0V	MAX388	25		25			pF
			MAX389	12		12			
WR Pulse Width	t _{WW}	Figure 1	300			300			ns
A _x , EN Data Valid to WR	t _{DW}	Setup time, Figure 1	210			180			ns
A _x , EN Data Valid after WR	t _{WD}	Hold time, Figure 1	30			10	0		ns
RS Pulse Width	t _{RS}	V _{IN} = 5V, Figure 1	500			300			ns
SUPPLY									
Supply Range		(Note 6)	±4.5		±18.0	±4.5		±18.0	V
Positive Supply Current	I+	V _{EN} = 2.4V, V _A = 0V or 5V	1.0	2.0		1.0	2.0		mA
Negative Supply Current	I-		1.2	2.5		1.2	2.5		

Note 2: Leakage currents at T_{MIN} guaranteed, but not tested.

Note 3: Digital input leakage is primarily due to the clamp diodes. Typical leakage is less than 1nA at +25°C.

Note 4: When the analog signal exceeds +13.5V or -12V, the blocking action of Maxim's gate structure operates. Only leakage currents flow, and the channel on resistance rises.

Note 5: The value shown is the steady-state value. The transient leakage is typically 50μA. See Detailed Description.

Note 6: Electrical characteristics such as r_{DS(ON)} will change when power supplies other than ±15V are used.

High-Voltage, Fault-Protected Analog Multiplexers

Typical Operating Characteristics

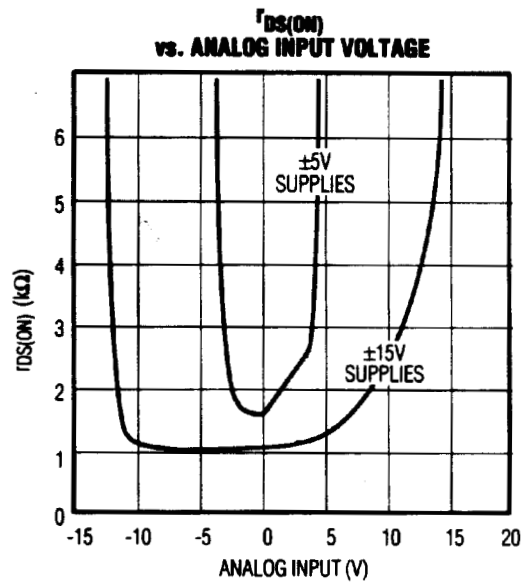
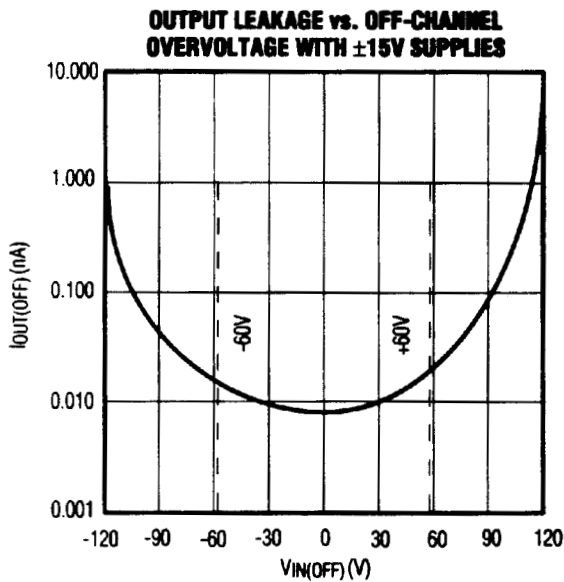
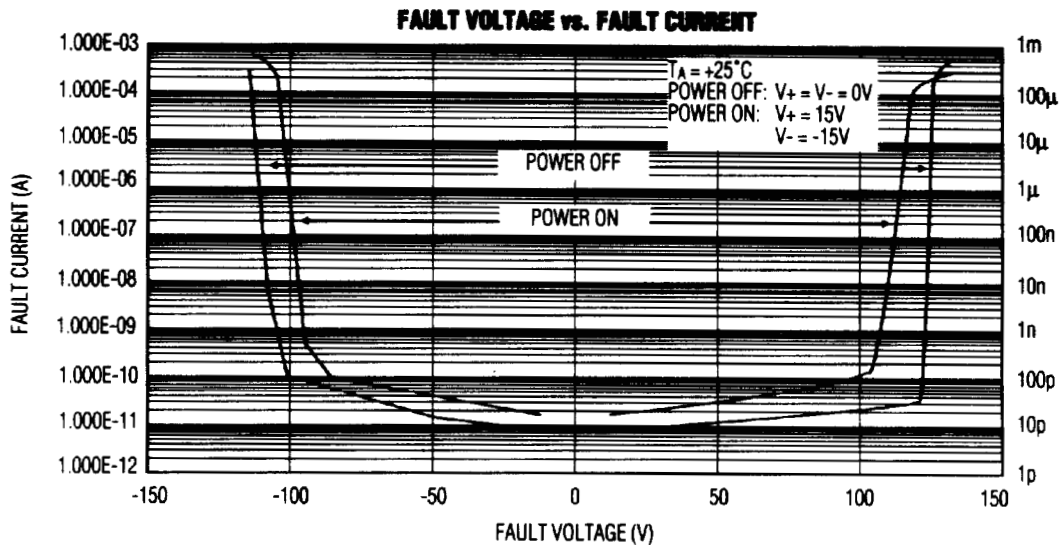

High-Voltage, Fault-Protected Analog Multiplexers

MAX388/MAX389

Detailed Description Fault-Protection Circuitry

The MAX388/MAX389 are fully fault-protected for continuous input voltages up to $\pm 100V$, whether or not the $V+$ and $V-$ power supplies are present

($\pm 115V$ with power off). These muxes use a series FET^{*} switching scheme that protects the mux output from overvoltage while limiting the input current to sub-microamp levels. Figures 7 and 8 show input leakage-current levels during overvoltage (Figure 7) and with power off (Figure 8).

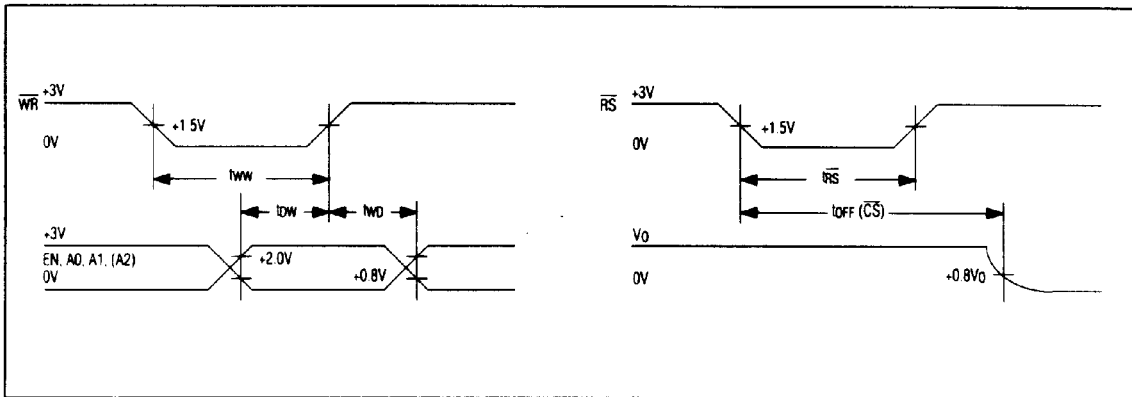

Figure 1. MAX388/MAX389 Typical Timing Diagrams

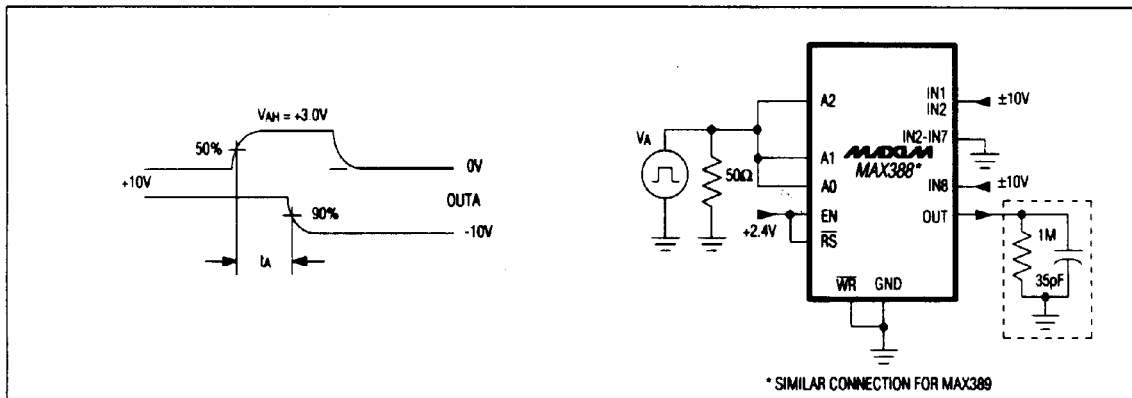

Figure 2. Access Time vs. Logic Level (High)

High-Voltage, Fault-Protected Analog Multiplexers

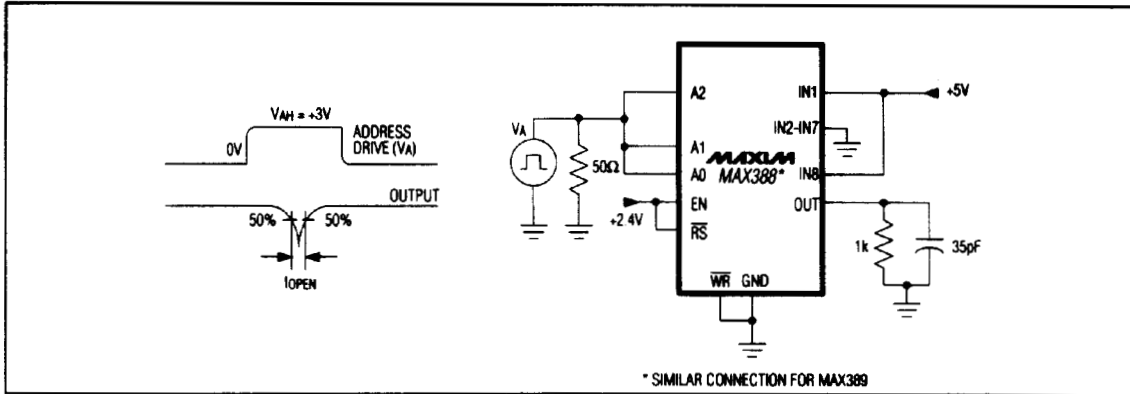

Figure 3. Break-Before-Make Delay (t_{OPEN})

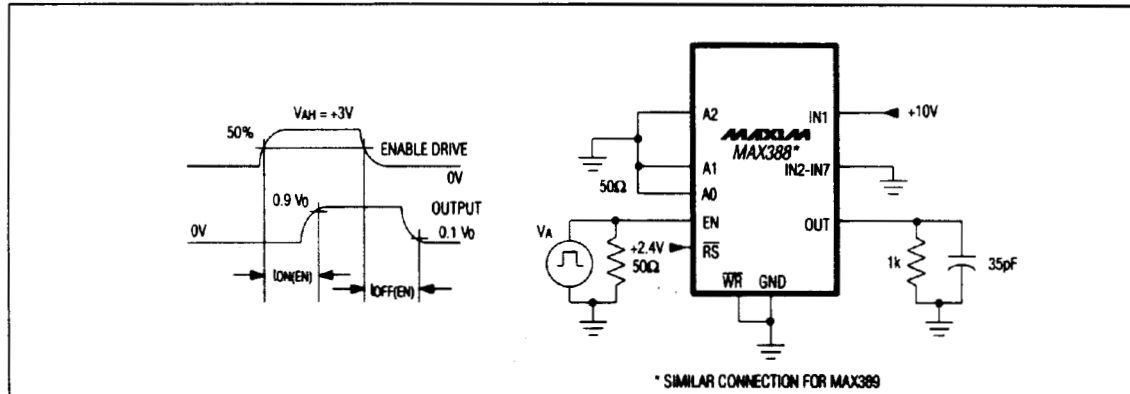

Figure 4. Enable Delay ($t_{ON(EN)}$, $t_{OFF(EN)}$)

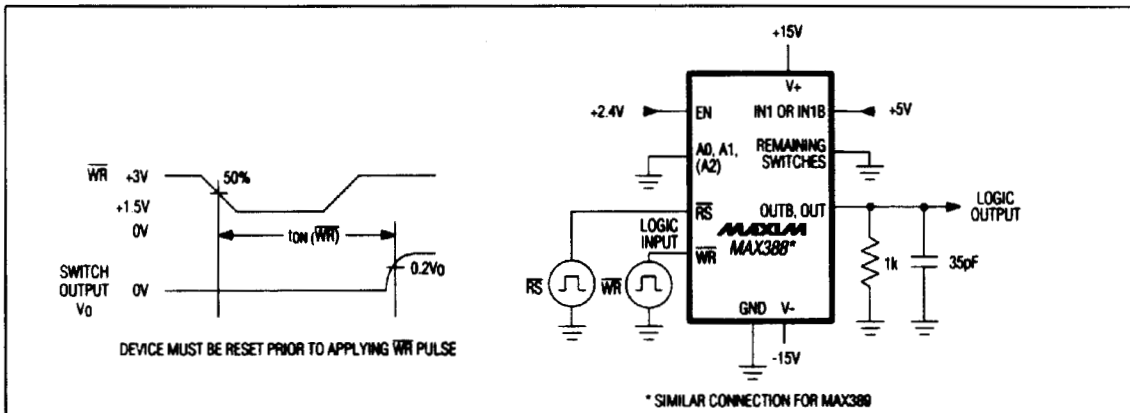

Figure 5. Write Turn-On Time ($t_{ON(WR)}$)

High-Voltage, Fault-Protected Analog Multiplexers

MAX388/MAX389

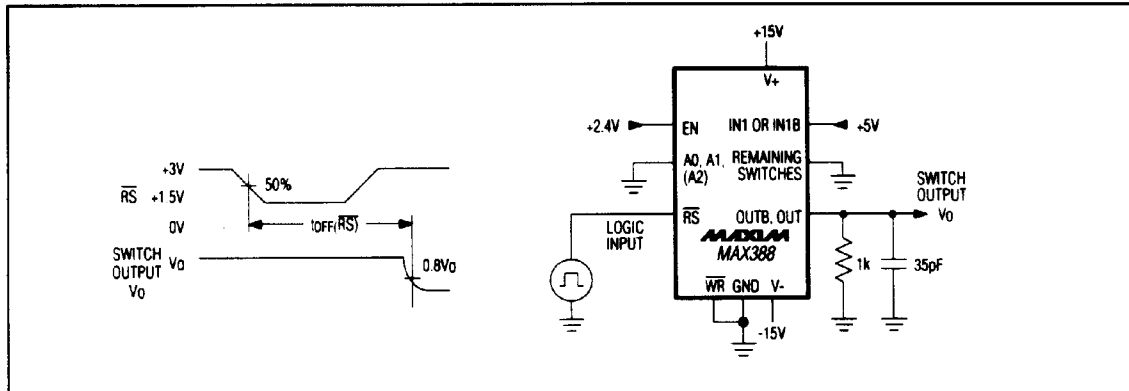

Figure 6. Reset Turn-Off Time ($t_{OFF}(RS)$)

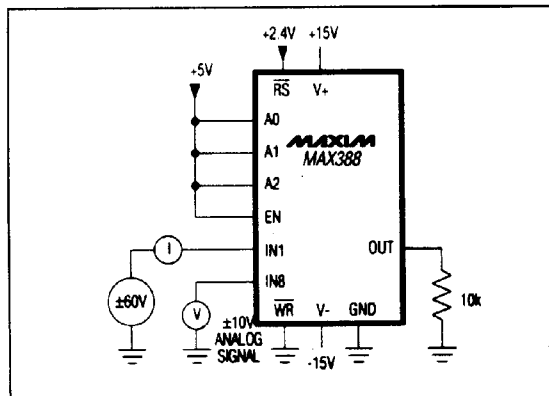

Figure 7. Input Leakage Current (Overvoltage)

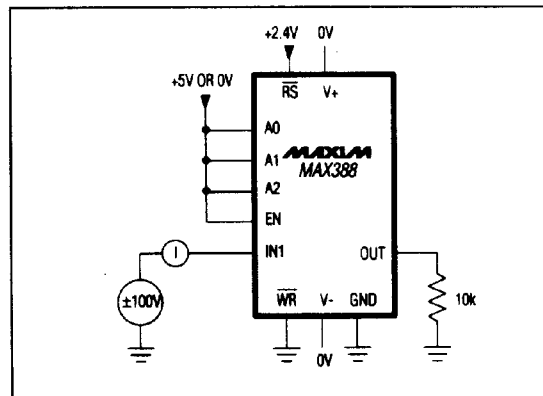

Figure 8. Input Leakage Current (Power Supplies Off)

Figures 9 and 10 show how the series FET circuit protects against overvoltage conditions. When power is off, the gates of all three FETs are at ground. With a $-100V$ input, N-channel FET Q1 is turned on by the $+100V$ gate-to-source voltage. However, the P-channel device Q2 with a V_{GS} of $+100V$ turns off, thereby preventing the input signal from reaching the output. If the input voltage is $+100V$, Q1 has a negative V_{GS} , which turns it off. Similarly, with overvoltage on the output, only sub-microamp leakage currents flow from the output back to the input, since overvoltages turn off either Q1 or Q2.

Figure 11 shows an off channel with $V+$ and $V-$ present. As with Figures 9 and 10, either an N-channel or a P-channel device will be off for any input voltage from $-100V$ to $+100V$. The leakage current with negative over-

voltages immediately drops to a few nanoamps at $+25^{\circ}C$. The fault current for positive overvoltages is initially $40\mu A$ to $50\mu A$, decaying over a few seconds to the nanoamp level. The time constant of this decay is due to stored charge on internal nodes and does not compromise fault-protection.

Figure 12 shows an on channel with $V+$ and $V-$ present. With input voltages less than $\pm 10V$, all three FETs are on, and the input signal appears at the output. If the input voltage exceeds $V+$ minus the N-channel threshold voltage (V_{TN}), the N-channel FET will turn off. Since V_{TN} is typically $1.5V$ and the P-channel threshold voltage (V_{TP}) is typically $3V$, the muxes' output swing is limited to approximately $-12V$ to $+13.5V$ with $\pm 15V$ supplies.

High-Voltage, Fault-Protected Analog Multiplexers

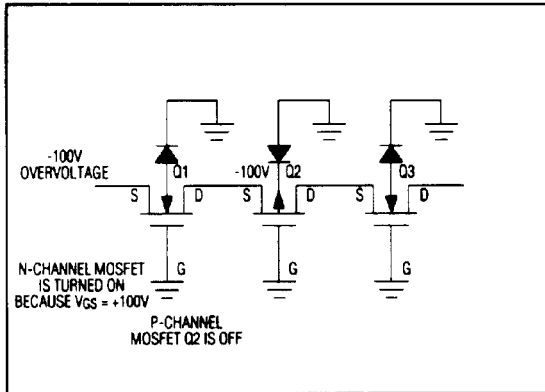

Figure 9. -100V Overvoltage with Mux Power Off

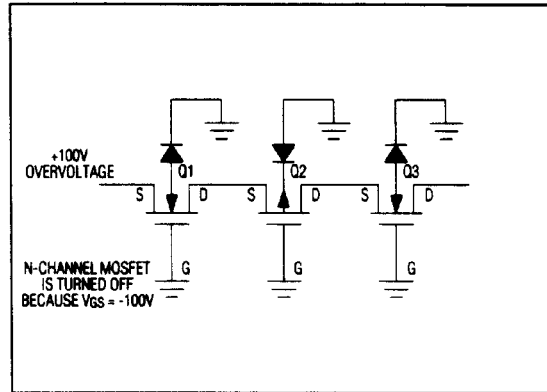

Figure 10. +100V Overvoltage with Mux Power Off

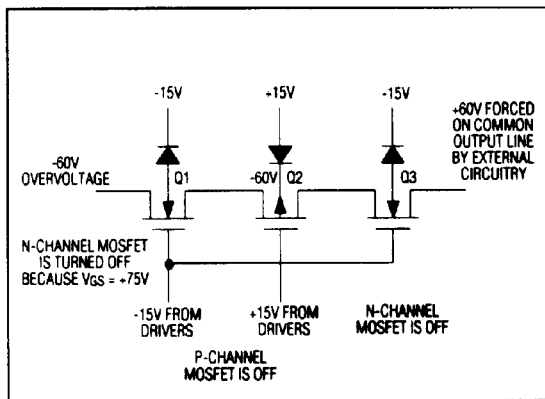

Figure 11. Off-Channel Overvoltage (-60V) with Mux Power On

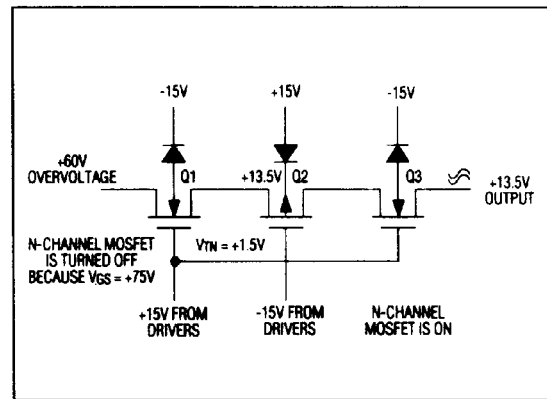

Figure 12. On-Channel Overvoltage (+60V) with Mux Power On

The *Typical Operating Characteristics* graphs show typical fault leakage vs. fault voltage curves. The MAX388/MAX389 muxes perform well up to the $\pm 115\text{V}$ maximum rating, providing an additional safety margin.

Switching Characteristics and Charge Injection

MAX388/MAX389 channel-to-channel switching time is typically 600ns, including approximately 200ns of break-before-make delay. This delay prevents the input-to-input short that would occur if two input channels were simultaneously connected to the output. In a typical data-acquisition system (Figure 13), the dominant delay is not the MAX388 mux switching time, but the settling

time of the following amplifiers and sample-and-hold (S/H). Another limiting factor is the RC time constant formed by the mux $r_{DS(ON)}$ plus the signal source impedance times the load capacitance on the mux output. Even with low signal-source impedances, 100pF capacitance on the mux output approximately doubles the settling time to 0.01% accuracy.

Tables 2a and 2b show typical charge injection levels vs. power-supply voltage and analog input voltages. Note: Since channels are well matched, differential charge injection for the MAX389 is typically less than 5pC. Charge injection that occurs during switching creates a voltage transient with a magnitude inversely proportional to mux output capacitance.

High-Voltage, Fault-Protected Analog Multiplexers

MAX388/MAX389

Table 1a. MAX388 Truth Table



A2	A1	A0	EN	WR	RS	ON SWITCH
Latching						
X	X	X	X		1	Maintains previous switch condition
Reset						
X	X	X	X	X	0	NONE (latches cleared)
Transparent Operation						
X	X	X	0	0	1	NONE
0	0	0	1	0	1	1
0	0	1	1	0	1	2
0	1	0	1	0	1	3
0	1	1	1	0	1	4
1	0	0	1	0	1	5
1	0	1	1	0	1	6
1	1	0	1	0	1	7
1	1	1	1	0	1	8

Table 1b. MAX389 Truth Table

A1	A0	EN	WR	RS	ON SWITCH
Latching					
X	X	X		1	Maintains previous switch condition
Reset					
X	X	X	X	0	NONE (latches cleared)
Transparent Operation					
X	X	0	0	1	NONE
0	0	1	0	1	1
0	1	1	0	1	2
1	0	1	0	1	3
1	1	1	0	1	4

NOTE: Logic '1': $V_{AH} \geq 2.4V$, Logic '0': $V_{AL} \leq 0.8V$

Operation from Supply Voltages Other than $\pm 15V$

The main limitation of supply voltages other than $\pm 15V$ is a reduction in output signal range. The MAX388 limits the output voltage to typically 1.5V below V_+ and 3V above V_- . Output swing is limited to +3.5V to -2V when operating from $\pm 5V$. The *Typical Operating Characteristics* graphs show typical $r_{DS(ON)}$ for $\pm 15V$, $\pm 10V$, and $\pm 5V$ supplies. Operation is guaranteed for $\pm 4.5V$ to $\pm 18V$ supplies. Switching delays increase by a factor of two or more at $\pm 5V$, but break-before-make operation is preserved.

The MAX388/MAX389 may be powered from a single +9V to +22V supply, as well as from unbalanced supplies such as +15V and -5V. Connect V_- to 0V when operating with a +9V to +22V single supply. The digital threshold remains approximately 1.6V above GND, and analog characteristics (such as $r_{DS(ON)}$) are determined by total voltage difference between V_+ and V_- . This means the MAX388/MAX389 operate with standard TTL logic levels, even with $\pm 5V$ power supplies.

Table 2a. MAX388 Charge Injection

Supply Voltage (V)	Analog Input Level (V)	Injected Charge (pC)
± 5	1.7	100
	0.0	70
	-1.7	45
± 10	5.0	200
	0.0	130
	-5.0	60
± 15	10.0	500
	0.0	180
	-10.0	50

Test Conditions: $C_L = 1000pF$ on mux output; the tabulated analog input level is applied to channel 1; channels 2 through 8 inputs are open circuited. $EN = +5V$, $A1 = A2 = 0V$, $A0$ is toggled at 2kHz rate between 0V and 3V. +100pC of charge creates a +100mV step when injected into a 1000pF load capacitance.

High-Voltage, Fault-Protected Analog Multiplexers

Table 2b. MAX389 Charge Injection

Supply Voltage (V)	Analog Input Level (V)	Injected Charge (pC)		
		OUTA	OUTB	Differential A-B
±5	1.7	105	107	-2
	0.0	73	74	-1
	-1.7	48	50	-2
±10	5.0	215	220	-5
	0.0	135	139	-4
	-5.0	62	63	-1
±15	10.0	525	530	-5
	0.0	180	185	-5
	-10.0	55	55	0

Test Conditions: $C_L = 1000\text{pF}$ on OUTA and OUTB; the tabulated analog input level is applied to inputs 1A and 1B; channels 2 through 4 are open circuited. EN = +5V, A1 = 0V, A0 is toggled from 0V to 3V at a 2kHz rate.

Digital-Interface Levels

The typical digital threshold of both the address lines and the Enable (EN) input is 1.6V, with a temperature coefficient of about $-3\text{mV}/^\circ\text{C}$. This ensures compatibility with a 0.8V to 2.4V TTL logic swing over the entire temperature range. The digital threshold is relatively independent of the supply voltages, typically moving from 1.6V to 1.5V as the power supplies are reduced from $\pm 15\text{V}$ to $\pm 5\text{V}$. In all cases, digital thresholds are referenced to GND.

The digital inputs can also be driven with CMOS logic levels swinging from either V_+ to V_- or from V_+ to GND. Digital input current is just a few nanoamps leakage at all input voltage levels, with a guaranteed maximum of $1\mu\text{A}$. The digital inputs are protected from ESD by a 30V zener diode between the input and V_+ , and can be driven $\pm 4\text{V}$ beyond the supplies without drawing excessive current.

Operation as Demultiplexers

The MAX388/MAX389 function as demultiplexers when an input is applied to the Output (OUT) pin, and channel inputs are used as outputs. Break-before-make operation and full fault protection are provided when operating as demultiplexers, unlike first-generation fault-protected muxes.

Table 3a. Typical Off-Isolation Rejection Ratio

Frequency (Hz)	100k	500k	1M
One Channel Driven (dB)	74	72	66
All Channels Driven (dB)	64	48	44

Test Conditions: $V_{IN} = 20\text{V}_{\text{p-p}}$ at the tabulated frequency, $R_L = 1.5\text{k}$ between OUT and GND, EN = 0V.

$$\text{OIRR} = 20 \log \frac{20\text{V}}{V_{\text{out}}}$$

Table 3b. Typical Crosstalk Rejection Ratio

Frequency (Hz)	100k	500k	1M
$F_L = 1.5\text{k}$ (dB)	70	68	64
$R_L = 10\text{k}$ (dB)	62	46	42

Test Conditions: Specified R_L connected from OUT to Ground. EN = +5V, A0 = A1 = A2 = +5V (channel 1 selected). $20\text{V}_{\text{p-p}}$ at the tabulated frequency is applied to channel 2. All other channels are open circuited. Similar crosstalk rejection can be observed between any two channels.

Leakage, Crosstalk, and Isolation

At DC and low frequencies, channel-to-channel crosstalk is caused by variation in output leakage currents as the off-channel input voltages are varied. The MAX388 output leakage varies only a few picoamps as all seven off inputs are toggled from -10V to $+10\text{V}$. The output voltage change depends on the impedance level at the MAX388 output ($r_{DS(\text{ON})}$ plus the input-signal source resistance), since the load driven by the MAX388 is usually a high impedance. For a signal source impedance of $10\text{k}\Omega$ or lower, DC crosstalk exceeds 120dB.

Tables 3a and 3b show typical AC crosstalk and off-isolation performance. Digital feedthrough is masked by analog charge injection when the output is enabled. When the output is disabled, digital feedthrough is virtually unmeasurable, since the digital pins are physically isolated from the analog section by the GND and V_- pins. The guard formed by these lines is continued onto the MAX388/MAX389 die to provide over 100dB isolation between the digital and analog sections at $f = 100\text{kHz}$.

High-Voltage, Fault-Protected Analog Multiplexers

MAX388/MAX389

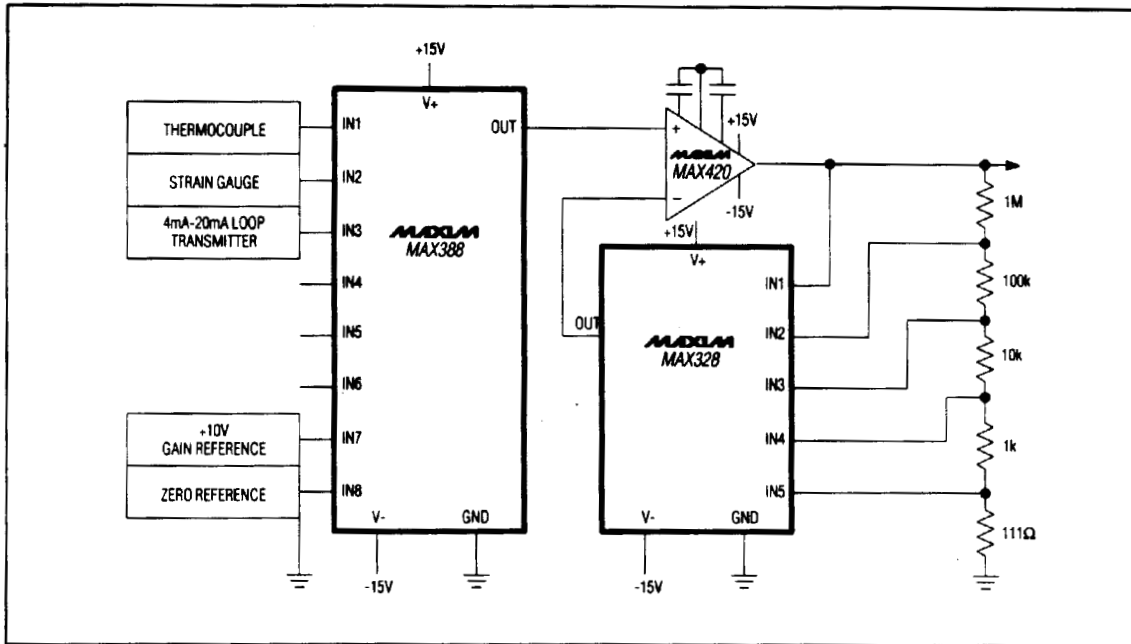

Figure 13. Typical Data-Acquisition Front End

Applications Information

Figure 13 shows a typical data-acquisition system incorporating the MAX388. Since the mux is driving a high-impedance input, the error is a function of the mux on resistance ($r_{DS(ON)}$) times the leakage current ($I_{OUT(ON)}$) and the amplifier bias current (I_{BIAS}):

$$\begin{aligned} V_{ERR} &= [r_{DS(ON)}] [I_{OUT(ON)} + I_{BIAS(MAX420)}] \\ &= (3k\Omega) (2nA + 30pA) \\ &= 6.1\mu V \text{ maximum error} \end{aligned}$$

In most cases, this error is low enough that preamplification of input signals is not needed, even with very low-level signals, such as $40\mu V/^\circ C$ from type J thermocouples.

In systems with fewer than eight inputs, an unused channel can be connected to the system ground reference point for software-zero correction. A second channel connected to the system voltage reference allows gain correction of the entire data-acquisition system as well.

A MAX420 precision op amp is connected as a programmable gain amplifier, with gains ranging from 1 to 10,000.

The guaranteed $5\mu V$ unadjusted MAX420 offset voltage maintains high-signal accuracy, while programmable gain allows the output signal level to be scaled to the optimum range for the remainder of the data-acquisition system, normally an S/H and an ADC. Since the gain-changing mux is not connected to external sensors and this point in the circuit does not require fault protection, the MAX328 low-leakage mux works well here.

Input switching, however, needs fault protection to provide the protection and isolation required for most data-acquisition inputs. Since external signal sources may continue to supply voltage when the system power is off, non-fault-protected muxes, or even first-generation fault-protected devices, allow many milliamps of fault current to flow from outside sources into the mux.

The MAX388/MAX389 eliminate these problems by limiting output voltage to safe levels (with or without power applied) and by turning all channels off when power is removed. Consequently, only sub-microamp fault currents are maintained for continuous input levels up to $\pm 100V$ with power supplies off.

High-Voltage, Fault-Protected Analog Multiplexers

Ordering Information (continued)

PART	TEMP. RANGE	PIN-PACKAGE
MAX389CPN	0°C to +70°C	18 Plastic DIP
MAX389CJN	0°C to +70°C	18 CERDIP
MAX389CWG	0°C to +70°C	24 SO
MAX389C/D	0°C to +70°C	Dice*
MAX389EPN	-40°C to +85°C	18 Plastic DIP
MAX389EJN	-40°C to +85°C	18 CERDIP
MAX389EWG	-55°C to +125°C	24 SO
MAX389MJN	-55°C to +125°C	18 CERDIP**

*Contact factory for dice specifications.

**Contact factory for availability and processing to MIL-STD-883.

Pin Configurations (continued)

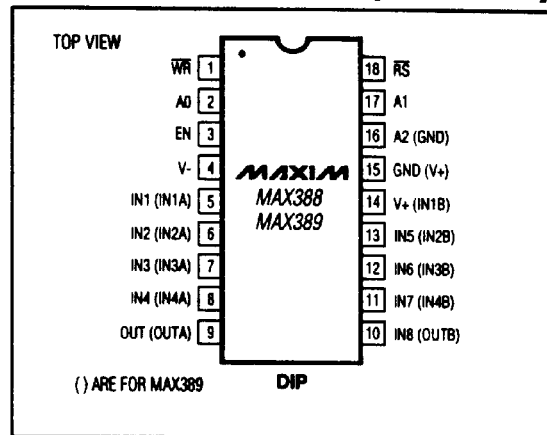

Chip Topography

DIE PAD #	MAX388	MAX389
1	WR	WR
2	A0	A0
3	EN	EN
4	V-	V-
5	IN1	IN1A
6	IN2	IN2A
7	IN3	IN3A
8	IN4	IN4A
9	OUT	OUTA
10	N.C.	OUTB
11	IN8	IN4B
12	IN7	IN3B
13	IN6	IN2B
14	IN5	IN1B
15	V+	V+
16	GND	GND
17	A2	N.C.
18	A1	A1
19	RS	RS

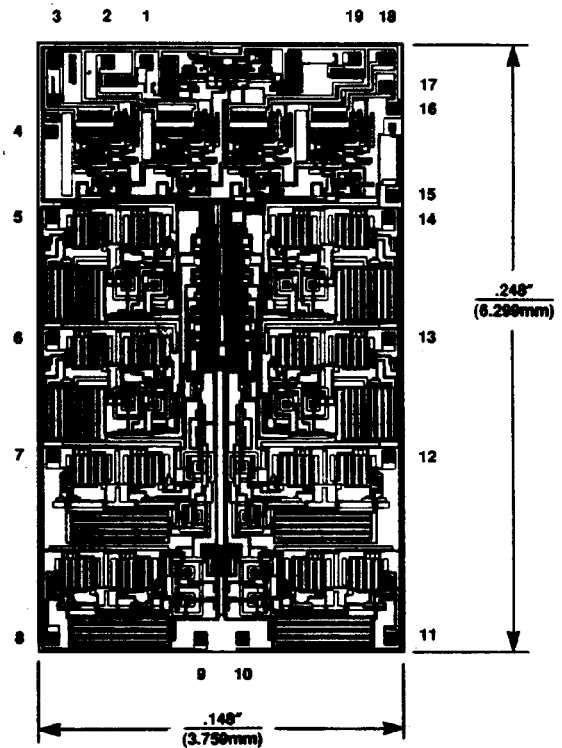

Maxim cannot assume responsibility for use of any circuitry other than circuitry entirely embodied in a Maxim product. No circuit patent licenses are implied. Maxim reserves the right to change the circuitry and specifications without notice at any time.

12 Maxim Integrated Products, 120 San Gabriel Drive, Sunnyvale, CA 94086 (408) 737-7600