



查询CY7C1381D-133AXI供应商

捷多邦, 专业PCB打样工厂, 24小时加急出货

**CY7C1381D, CY7C1381F
CY7C1383D, CY7C1383F**

18-Mbit (512K x 36/1M x 18) Flow-Through SRAM

Features

- Supports 133 MHz bus operations
- 512K x 36 and 1M x 18 common IO
- 3.3V core power supply (V_{DD})
- 2.5V or 3.3V IO supply (V_{DDQ})
- Fast clock-to-output time
— 6.5 ns (133 MHz version)
- Provides high performance 2-1-1-1 access rate
- User selectable burst counter supporting Intel® Pentium® interleaved or linear burst sequences
- Separate processor and controller address strobes
- Synchronous self-timed write
- Asynchronous output enable
- CY7C1381D/CY7C1383D available in JEDEC-standard Pb-free 100-pin TQFP, Pb-free and non Pb-free 165-ball FBGA package. CY7C1381F/CY7C1383F available in Pb-free and non Pb-free 119-ball BGA package
- IEEE 1149.1 JTAG-Compatible Boundary Scan
- ZZ sleep mode option

Functional Description ^[1]

The CY7C1381D/CY7C1383D/CY7C1381F/CY7C1383F is a 3.3V, 512K x 36 and 1M x 18 synchronous flow through SRAMs, designed to interface with high-speed microprocessors with minimum glue logic. Maximum access delay from clock rise is 6.5 ns (133 MHz version). A 2-bit on-chip counter captures the first address in a burst and increments the address automatically for the rest of the burst access. All synchronous inputs are gated by registers controlled by a positive edge triggered clock input (CLK). The synchronous inputs include all addresses, all data inputs, address pipelining chip enable (CE_1), depth-expansion chip enables (CE_2 and CE_3 ^[2]), burst control inputs (ADSC, ADSP, and ADV), write enables (BW_x , and BWE), and global write (\overline{GW}). Asynchronous inputs include the output enable (\overline{OE}) and the ZZ pin.

The CY7C1381D/CY7C1383D/CY7C1381F/CY7C1383F allows interleaved or linear burst sequences, selected by the MODE input pin. A HIGH selects an interleaved burst sequence, while a LOW selects a linear burst sequence. Burst accesses can be initiated with the processor address strobe (ADSP) or the cache controller address strobe (ADSC) inputs. Address advancement is controlled by the address advancement (ADV) input.

Addresses and chip enables are registered at rising edge of clock when address strobe processor (ADSP) or address strobe controller (ADSC) are active. Subsequent burst addresses can be internally generated as controlled by the advance pin (\overline{ADV}).

The CY7C1381D/CY7C1383D/CY7C1381F/CY7C1383F operates from a +3.3V core power supply while all outputs operate with a +2.5V or +3.3V supply. All inputs and outputs are JEDEC-standard and JESD8-5-compatible.

Selection Guide

| | 133 MHz | 100 MHz | Unit |
|------------------------------|---------|---------|------|
| Maximum Access Time | 6.5 | 8.5 | ns |
| Maximum Operating Current | 210 | 175 | mA |
| Maximum CMOS Standby Current | 70 | 70 | mA |

Notes:

1. For best practices or recommendations, please refer to the Cypress application note AN1064, *SRAM System Design Guidelines* on www.cypress.com.
2. CE_3 , CE_2 are for TQFP and 165 FBGA packages only. 119 BGA is offered only in 1 chip enable.

Logic Block Diagram – CY7C1381D/CY7C1381F [3] (512K x 36)

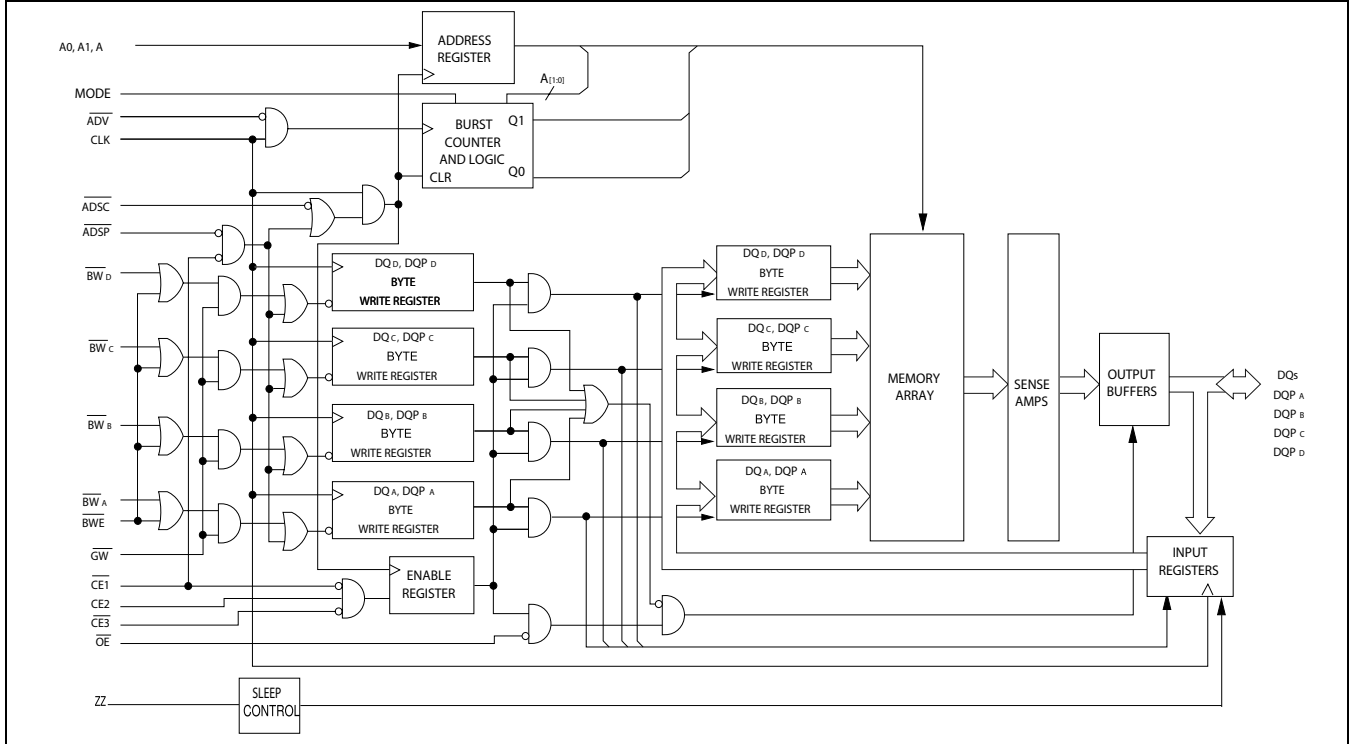

Logic Block Diagram – CY7C1383D/CY7C1383F[3] (1M x 18)

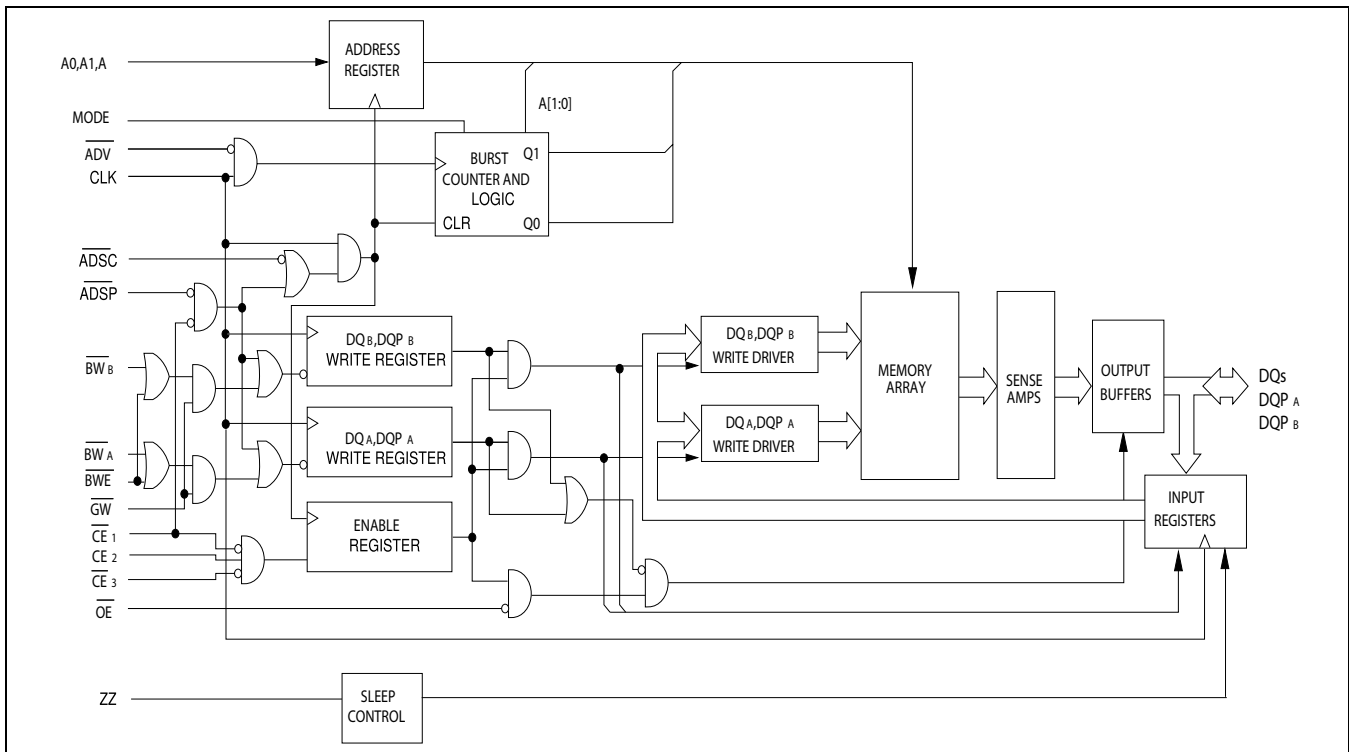

Note:
3. CY7C1381F and CY7C1383F have only 1 chip enable (\overline{CE}_1).

Pin Configurations

100-pin TQFP Pinout (3 Chip Enable)

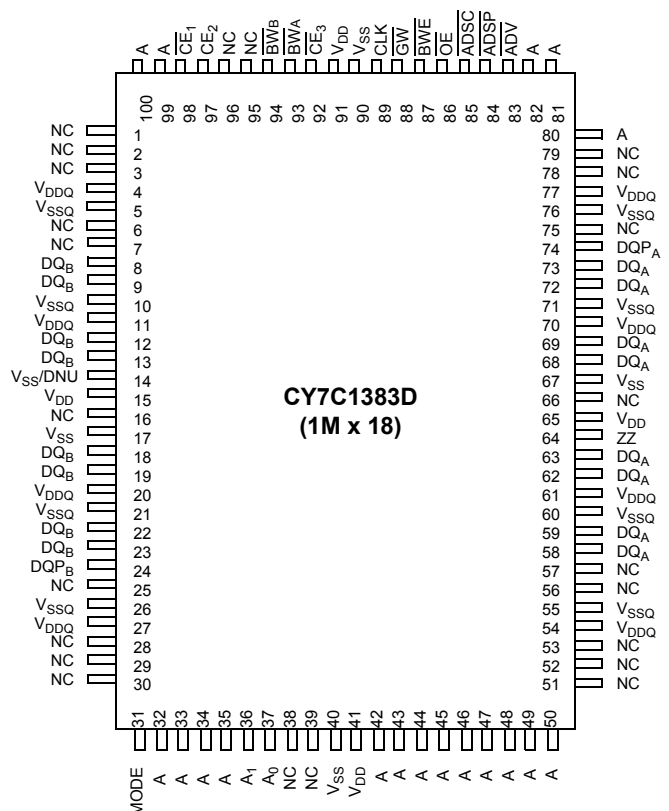
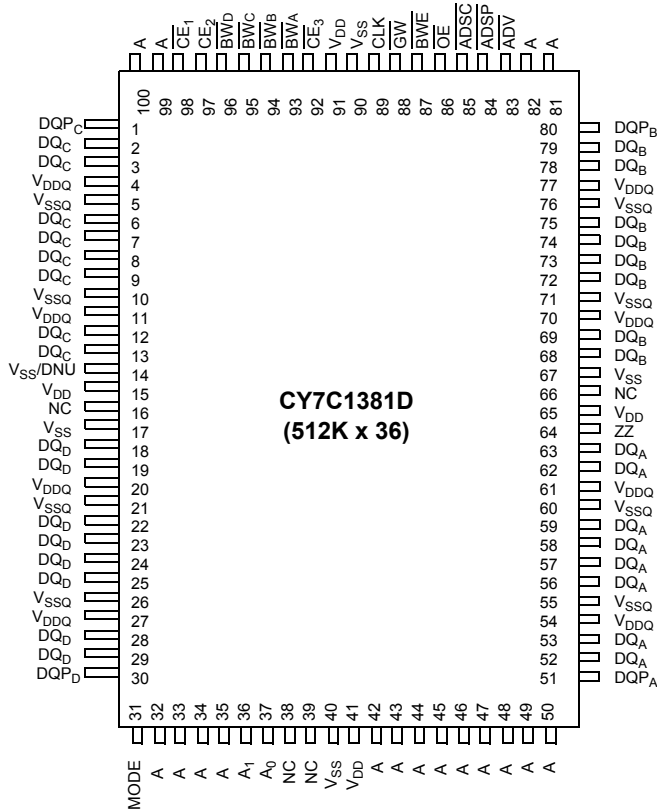



Pin Configurations (continued)

**119-Ball BGA Pinout
CY7C1381F (512K x 36)**

| | 1 | 2 | 3 | 4 | 5 | 6 | 7 |
|----------|------------------|------------------|--------------------------|--------------------------|--------------------------|------------------|------------------|
| A | V _{DDQ} | A | A | $\overline{\text{ADSP}}$ | A | A | V _{DDQ} |
| B | NC/288M | A | A | $\overline{\text{ADSC}}$ | A | A | NC/576M |
| C | NC/144M | A | A | V _{DD} | A | A | NC/1G |
| D | DQ _C | DQP _C | V _{SS} | NC | V _{SS} | DQP _B | DQ _B |
| E | DQ _C | DQ _C | V _{SS} | $\overline{\text{CE}}_1$ | V _{SS} | DQ _B | DQ _B |
| F | V _{DDQ} | DQ _C | V _{SS} | $\overline{\text{OE}}$ | V _{SS} | DQ _B | V _{DDQ} |
| G | DQ _C | DQ _C | $\overline{\text{BW}}_C$ | $\overline{\text{ADV}}$ | $\overline{\text{BW}}_B$ | DQ _B | DQ _B |
| H | DQ _C | DQ _C | V _{SS} | $\overline{\text{GW}}$ | V _{SS} | DQ _B | DQ _B |
| J | V _{DDQ} | V _{DD} | NC | V _{DD} | NC | V _{DD} | V _{DDQ} |
| K | DQ _D | DQ _D | V _{SS} | CLK | V _{SS} | DQ _A | DQ _A |
| L | DQ _D | DQ _D | $\overline{\text{BW}}_D$ | NC | $\overline{\text{BW}}_A$ | DQ _A | DQ _A |
| M | V _{DDQ} | DQ _D | V _{SS} | $\overline{\text{BWE}}$ | V _{SS} | DQ _A | V _{DDQ} |
| N | DQ _D | DQ _D | V _{SS} | A1 | V _{SS} | DQ _A | DQ _A |
| P | DQ _D | DQP _D | V _{SS} | A0 | V _{SS} | DQP _A | DQ _A |
| R | NC | A | MODE | V _{DD} | NC | A | NC |
| T | NC | NC/72M | A | A | A | NC/36M | ZZ |
| U | V _{DDQ} | TMS | TDI | TCK | TDO | NC | V _{DDQ} |

CY7C1383F (1M x 18)

| | 1 | 2 | 3 | 4 | 5 | 6 | 7 |
|----------|------------------|------------------|--------------------------|--------------------------|--------------------------|------------------|------------------|
| A | V _{DDQ} | A | A | $\overline{\text{ADSP}}$ | A | A | V _{DDQ} |
| B | NC/288M | A | A | $\overline{\text{ADSC}}$ | A | A | NC/576M |
| C | NC/144M | A | A | V _{DD} | A | A | NC/1G |
| D | DQ _B | NC | V _{SS} | NC | V _{SS} | DQP _A | NC |
| E | NC | DQ _B | V _{SS} | $\overline{\text{CE}}_1$ | V _{SS} | NC | DQ _A |
| F | V _{DDQ} | NC | V _{SS} | $\overline{\text{OE}}$ | V _{SS} | DQ _A | V _{DDQ} |
| G | NC | DQ _B | $\overline{\text{BW}}_B$ | $\overline{\text{ADV}}$ | NC | NC | DQ _A |
| H | DQ _B | NC | V _{SS} | $\overline{\text{GW}}$ | V _{SS} | DQ _A | NC |
| J | V _{DDQ} | V _{DD} | NC | V _{DD} | NC | V _{DD} | V _{DDQ} |
| K | NC | DQ _B | V _{SS} | CLK | V _{SS} | NC | DQ _A |
| L | DQ _B | NC | NC | NC | $\overline{\text{BW}}_A$ | DQ _A | NC |
| M | V _{DDQ} | DQ _B | V _{SS} | $\overline{\text{BWE}}$ | V _{SS} | NC | V _{DDQ} |
| N | DQ _B | NC | V _{SS} | A1 | V _{SS} | DQ _A | NC |
| P | NC | DQP _B | V _{SS} | A0 | V _{SS} | NC | DQ _A |
| R | NC | A | MODE | V _{DD} | NC | A | NC |
| T | NC/72M | A | A | NC/36M | A | A | ZZ |
| U | V _{DDQ} | TMS | TDI | TCK | TDO | NC | V _{DDQ} |



Pin Configurations (continued)

165-Ball FBGA Pinout(3 Chip Enable)

CY7C1381D (512K x 36)

| | 1 | 2 | 3 | 4 | 5 | 6 | 7 | 8 | 9 | 10 | 11 |
|----------|------------------|-----------------|-------------------|-------------------|-------------------|-------------------|------------------|-------------------|-------------------|-----------------|------------------|
| A | NC/288M | A | \overline{CE}_1 | \overline{BW}_C | \overline{BW}_B | \overline{CE}_3 | \overline{BWE} | \overline{ADSC} | \overline{ADV} | A | NC |
| B | NC/144M | A | CE_2 | \overline{BW}_D | \overline{BW}_A | CLK | \overline{GW} | \overline{OE} | \overline{ADSP} | A | NC/576M |
| C | DQP _C | NC | V _{DDQ} | V _{SS} | V _{SS} | V _{SS} | V _{SS} | V _{SS} | V _{DDQ} | NC/1G | DQP _B |
| D | DQ _C | DQ _C | V _{DDQ} | V _{DD} | V _{SS} | V _{SS} | V _{SS} | V _{DD} | V _{DDQ} | DQ _B | DQ _B |
| E | DQ _C | DQ _C | V _{DDQ} | V _{DD} | V _{SS} | V _{SS} | V _{SS} | V _{DD} | V _{DDQ} | DQ _B | DQ _B |
| F | DQ _C | DQ _C | V _{DDQ} | V _{DD} | V _{SS} | V _{SS} | V _{SS} | V _{DD} | V _{DDQ} | DQ _B | DQ _B |
| G | DQ _C | DQ _C | V _{DDQ} | V _{DD} | V _{SS} | V _{SS} | V _{SS} | V _{DD} | V _{DDQ} | DQ _B | DQ _B |
| H | NC | NC | NC | V _{DD} | V _{SS} | V _{SS} | V _{SS} | V _{DD} | NC | NC | ZZ |
| J | DQ _D | DQ _D | V _{DDQ} | V _{DD} | V _{SS} | V _{SS} | V _{SS} | V _{DD} | V _{DDQ} | DQ _A | DQ _A |
| K | DQ _D | DQ _D | V _{DDQ} | V _{DD} | V _{SS} | V _{SS} | V _{SS} | V _{DD} | V _{DDQ} | DQ _A | DQ _A |
| L | DQ _D | DQ _D | V _{DDQ} | V _{DD} | V _{SS} | V _{SS} | V _{SS} | V _{DD} | V _{DDQ} | DQ _A | DQ _A |
| M | DQ _D | DQ _D | V _{DDQ} | V _{DD} | V _{SS} | V _{SS} | V _{SS} | V _{DD} | V _{DDQ} | DQ _A | DQ _A |
| N | DQP _D | NC | V _{DDQ} | V _{SS} | NC | A | NC | V _{SS} | V _{DDQ} | NC | DQP _A |
| P | NC | NC/72M | A | A | TDI | A1 | TDO | A | A | A | A |
| R | MODE | NC/36M | A | A | TMS | A0 | TCK | A | A | A | A |

CY7C1383D (1M x 18)

| | 1 | 2 | 3 | 4 | 5 | 6 | 7 | 8 | 9 | 10 | 11 |
|----------|------------------|-----------------|-------------------|-------------------|-------------------|-------------------|------------------|-------------------|-------------------|-----------------|------------------|
| A | NC/288M | A | \overline{CE}_1 | \overline{BW}_B | NC | \overline{CE}_3 | \overline{BWE} | \overline{ADSC} | \overline{ADV} | A | A |
| B | NC/144M | A | CE_2 | NC | \overline{BW}_A | CLK | \overline{GW} | \overline{OE} | \overline{ADSP} | A | NC/576M |
| C | NC | NC | V _{DDQ} | V _{SS} | V _{SS} | V _{SS} | V _{SS} | V _{SS} | V _{DDQ} | NC/1G | DQP _A |
| D | NC | DQ _B | V _{DDQ} | V _{DD} | V _{SS} | V _{SS} | V _{SS} | V _{DD} | V _{DDQ} | NC | DQ _A |
| E | NC | DQ _B | V _{DDQ} | V _{DD} | V _{SS} | V _{SS} | V _{SS} | V _{DD} | V _{DDQ} | NC | DQ _A |
| F | NC | DQ _B | V _{DDQ} | V _{DD} | V _{SS} | V _{SS} | V _{SS} | V _{DD} | V _{DDQ} | NC | DQ _A |
| G | NC | DQ _B | V _{DDQ} | V _{DD} | V _{SS} | V _{SS} | V _{SS} | V _{DD} | V _{DDQ} | NC | DQ _A |
| H | V _{SS} | NC | NC | V _{DD} | V _{SS} | V _{SS} | V _{SS} | V _{DD} | NC | NC | ZZ |
| J | DQ _B | NC | V _{DDQ} | V _{DD} | V _{SS} | V _{SS} | V _{SS} | V _{DD} | V _{DDQ} | DQ _A | NC |
| K | DQ _B | NC | V _{DDQ} | V _{DD} | V _{SS} | V _{SS} | V _{SS} | V _{DD} | V _{DDQ} | DQ _A | NC |
| L | DQ _B | NC | V _{DDQ} | V _{DD} | V _{SS} | V _{SS} | V _{SS} | V _{DD} | V _{DDQ} | DQ _A | NC |
| M | DQ _B | NC | V _{DDQ} | V _{DD} | V _{SS} | V _{SS} | V _{SS} | V _{DD} | V _{DDQ} | DQ _A | NC |
| N | DQP _B | NC | V _{DDQ} | V _{SS} | NC | A | NC | V _{SS} | V _{DDQ} | NC | NC |
| P | NC | NC/72M | A | A | TDI | A1 | TDO | A | A | A | A |
| R | MODE | NC/36M | A | A | TMS | A0 | TCK | A | A | A | A |

Pin Definitions

| Name | IO | Description |
|--|--------------------|--|
| A ₀ , A ₁ , A | Input-Synchronous | Address inputs used to select one of the address locations. Sampled at the rising edge of the CLK if $\overline{\text{ADSP}}$ or $\overline{\text{ADSC}}$ is active LOW, and $\overline{\text{CE}}_1$, CE ₂ , and $\overline{\text{CE}}_3$ ^[2] are sampled active. A _[1:0] feed the 2-bit counter. |
| $\overline{\text{BW}}_A$, $\overline{\text{BW}}_B$ $\overline{\text{BW}}_C$, $\overline{\text{BW}}_D$ | Input-Synchronous | Byte write select inputs, active LOW. Qualified with $\overline{\text{BWE}}$ to conduct byte writes to the SRAM. Sampled on the rising edge of CLK. |
| $\overline{\text{GW}}$ | Input-Synchronous | Global write enable input, active LOW. When asserted LOW on the rising edge of CLK, a global write is conducted (all bytes are written, regardless of the values on $\overline{\text{BW}}_{[A:D]}$ and $\overline{\text{BWE}}$). |
| CLK | Input-Clock | Clock input. Used to capture all synchronous inputs to the device. Also used to increment the burst counter when ADV is asserted LOW, during a burst operation. |
| $\overline{\text{CE}}_1$ | Input-Synchronous | Chip enable 1 input, active LOW. Sampled on the rising edge of CLK. Used in conjunction with CE ₂ and $\overline{\text{CE}}_3$ ^[2] to select or deselect the device. ADSP is ignored if CE ₁ is HIGH. CE ₁ is sampled only when a new external address is loaded. |
| CE ₂ | Input-Synchronous | Chip enable 2 input, active HIGH. Sampled on the rising edge of CLK. Used in conjunction with $\overline{\text{CE}}_1$ and $\overline{\text{CE}}_3$ ^[2] to select or deselect the device. CE ₂ is sampled only when a new external address is loaded. |
| $\overline{\text{CE}}_3$ ^[2] | Input-Synchronous | Chip enable 3 input, active LOW. Sampled on the rising edge of CLK. Used in conjunction with $\overline{\text{CE}}_1$ and CE ₂ to select or deselect the device. CE ₃ is sampled only when a new external address is loaded. |
| $\overline{\text{OE}}$ | Input-Asynchronous | Output enable, asynchronous input, active LOW. Controls the direction of the IO pins. When LOW, the IO pins behave as outputs. When deasserted HIGH, IO pins are tri-stated, and act as input data pins. OE is masked during the first clock of a read cycle when emerging from a deselected state. |
| $\overline{\text{ADV}}$ | Input-Synchronous | Advance input signal. Sampled on the rising edge of CLK. When asserted, it automatically increments the address in a burst cycle. |
| $\overline{\text{ADSP}}$ | Input-Synchronous | Address strobe from processor, sampled on the rising edge of CLK, active LOW. When asserted LOW, addresses presented to the device are captured in the address registers. A _[1:0] are also loaded into the burst counter. When $\overline{\text{ADSP}}$ and $\overline{\text{ADSC}}$ are both asserted, only $\overline{\text{ADSP}}$ is recognized. $\overline{\text{ADSP}}$ is ignored when CE ₁ is deasserted HIGH. |
| $\overline{\text{ADSC}}$ | Input-Synchronous | Address strobe from controller, sampled on the rising edge of CLK, active LOW. When asserted LOW, addresses presented to the device are captured in the address registers. A _[1:0] are also loaded into the burst counter. When $\overline{\text{ADSP}}$ and $\overline{\text{ADSC}}$ are both asserted, only $\overline{\text{ADSP}}$ is recognized. |
| $\overline{\text{BWE}}$ | Input-Synchronous | Byte write enable input, active LOW. Sampled on the rising edge of CLK. This signal must be asserted LOW to conduct a byte write. |
| ZZ | Input-Asynchronous | ZZ sleep input. This active HIGH input places the device in a non-time critical sleep condition with data integrity preserved. For normal operation, this pin has to be LOW or left floating. ZZ pin has an internal pull down. |
| DQ _s | IO-Synchronous | Bidirectional data IO lines. As inputs, they feed into an on-chip data register that is triggered by the rising edge of CLK. As outputs, they deliver the data contained in the memory location specified by the addresses presented during the previous clock rise of the read cycle. The direction of the pins is controlled by OE. When OE is asserted LOW, the pins behave as outputs. When HIGH, DQ _s and DQP _x are placed in a tri-state condition. The outputs are automatically tri-stated during the data portion of a write sequence, during the first clock when emerging from a deselected state, and when the device is deselected, regardless of the state of OE. |
| DQP _x | IO-Synchronous | Bidirectional data parity IO lines. Functionally, these signals are identical to DQ _s . During write sequences, DQP _x is controlled by $\overline{\text{BW}}_x$ correspondingly. |

Pin Definitions (continued)

| Name | IO | Description |
|--------------|--------------------------------|--|
| MODE | Input-Static | Selects burst order. When tied to GND selects linear burst sequence. When tied to V_{DD} or left floating selects interleaved burst sequence. This is a strap pin and must remain static during device operation. Mode pin has an internal pull up. |
| V_{DD} | Power Supply | Power supply inputs to the core of the device. |
| V_{DDQ} | IO Power Supply | Power supply for the IO circuitry. |
| V_{SS} | Ground | Ground for the core of the device. |
| V_{SSQ} | IO Ground | Ground for the IO circuitry. |
| TDO | JTAG serial output Synchronous | Serial data-out to the JTAG circuit. Delivers data on the negative edge of TCK. If the JTAG feature is not being utilized, this pin can be left unconnected. This pin is not available on TQFP packages. |
| TDI | JTAG serial input Synchronous | Serial data-in to the JTAG circuit. Sampled on the rising edge of TCK. If the JTAG feature is not being utilized, this pin can be left floating or connected to V_{DD} through a pull up resistor. This pin is not available on TQFP packages. |
| TMS | JTAG serial input Synchronous | Serial data-in to the JTAG circuit. Sampled on the rising edge of TCK. If the JTAG feature is not being utilized, this pin can be disconnected or connected to V_{DD} . This pin is not available on TQFP packages. |
| TCK | JTAG-Clock | Clock input to the JTAG circuitry. If the JTAG feature is not being utilized, this pin must be connected to V_{SS} . This pin is not available on TQFP packages. |
| NC | – | No connects. Not internally connected to the die. 36M, 72M, 144M, 288M, 576M, and 1G are address expansion pins and are not internally connected to the die. |
| V_{SS}/DNU | Ground/DNU | This pin can be connected to ground or can be left floating. |

Functional Overview

All synchronous inputs pass through input registers controlled by the rising edge of the clock. Maximum access delay from the clock rise (t_{CDV}) is 6.5 ns (133 MHz device).

The CY7C1381D/CY7C1383D/CY7C1381F/CY7C1383F supports secondary cache in systems utilizing a linear or interleaved burst sequence. The interleaved burst order supports Pentium® and i486™ processors. The linear burst sequence is suited for processors that utilize a linear burst sequence. The burst order is user selectable, and is determined by sampling the MODE input. Accesses can be initiated with the processor address strobe (\overline{ADSP}) or the controller address strobe (\overline{ADSC}). Address advancement through the burst sequence is controlled by the ADV input. A two-bit on-chip wraparound burst counter captures the first address in a burst sequence and automatically increments the address for the rest of the burst access.

Byte write operations are qualified with the byte write enable ($\overline{BW_E}$) and byte write select ($\overline{BW_X}$) inputs. A global write enable (\overline{GW}) overrides all byte write inputs and writes data to all four bytes. All writes are simplified with on-chip synchronous self-timed write circuitry.

Three synchronous chip selects ($\overline{CE_1}$, CE_2 , $\overline{CE_3}$ [2]) and an asynchronous output enable (\overline{OE}) provide for easy bank

selection and output tri-state control. \overline{ADSP} is ignored if $\overline{CE_1}$ is HIGH.

Single Read Accesses

A single read access is initiated when the following conditions are satisfied at clock rise: (1) $\overline{CE_1}$, CE_2 , and $\overline{CE_3}$ [2] are all asserted active, and (2) \overline{ADSP} or \overline{ADSC} is asserted LOW (if the access is initiated by \overline{ADSC} , the write inputs must be deasserted during this first cycle). The address presented to the address inputs is latched into the address register and the burst counter and/or control logic, and later presented to the memory core. If the OE input is asserted LOW, the requested data will be available at the data outputs with a maximum to t_{CDV} after clock rise. \overline{ADSP} is ignored if $\overline{CE_1}$ is HIGH.

Single Write Accesses Initiated by \overline{ADSP}

This access is initiated when the following conditions are satisfied at clock rise: (1) $\overline{CE_1}$, CE_2 , $\overline{CE_3}$ [2] are all asserted active, and (2) \overline{ADSP} is asserted LOW. The addresses presented are loaded into the address register and the burst inputs (\overline{GW} , $\overline{BW_E}$, and $\overline{BW_X}$) are ignored during this first clock cycle. If the write inputs are asserted active (see [Truth Table for Read/Write](#) [4, 9] on page 10 for appropriate states that indicate a write) on the next clock rise, the appropriate data will be latched and written into the device. Byte writes are allowed. All IOs are tri-stated during a byte write. As this is a common IO device, the asynchronous \overline{OE} input signal must be

deasserted and the IOs must be tri-stated prior to the presentation of data to DQs. As a safety precaution, the data lines are tri-stated once a write cycle is detected, regardless of the state of OE.

Single Write Accesses Initiated by $\overline{\text{ADSC}}$

This write access is initiated when the following conditions are satisfied at clock rise: (1) $\overline{\text{CE}}_1$, CE_2 , and $\overline{\text{CE}}_3$ [2] are all asserted active, (2) $\overline{\text{ADSC}}$ is asserted LOW, (3) $\overline{\text{ADSP}}$ is deasserted HIGH, and (4) the write input signals ($\overline{\text{GW}}$, $\overline{\text{BWE}}$, and $\overline{\text{BW}}_X$) indicate a write access. $\overline{\text{ADSC}}$ is ignored if $\overline{\text{ADSP}}$ is active LOW.

The addresses presented are loaded into the address register and the burst counter, the control logic, or both, and delivered to the memory core. The information presented to $\text{DQ}_{[A:D]}$ will be written into the specified address location. Byte writes are allowed. All IOs are tri-stated when a write is detected, even a byte write. Since this is a common IO device, the asynchronous OE input signal must be deasserted and the IOs must be tri-stated prior to the presentation of data to DQ_S . As a safety precaution, the data lines are tri-stated once a write cycle is detected, regardless of the state of OE.

Burst Sequences

The CY7C1381D/CY7C1383D/CY7C1381F/CY7C1383F provides an on-chip two-bit wraparound burst counter inside the SRAM. The burst counter is fed by $A_{[1:0]}$, and can follow either a linear or interleaved burst order. The burst order is determined by the state of the MODE input. A LOW on MODE will select a linear burst sequence. A HIGH on MODE will select an interleaved burst order. Leaving MODE unconnected will cause the device to default to a interleaved burst sequence.

ZZ Mode Electrical Characteristics

| Parameter | Description | Test Conditions | Min | Max | Unit |
|-------------|-----------------------------------|---------------------------|------------|------------|------|
| I_{DDZZ} | Sleep mode standby current | $ZZ \geq V_{DD} - 0.2V$ | | 80 | mA |
| t_{ZZS} | Device operation to ZZ | $ZZ \geq V_{DD} - 0.2V$ | | $2t_{CYC}$ | ns |
| t_{ZZREC} | ZZ recovery time | $ZZ \leq 0.2V$ | $2t_{CYC}$ | | ns |
| t_{ZZI} | ZZ active to sleep current | This parameter is sampled | | $2t_{CYC}$ | ns |
| t_{RZZI} | ZZ inactive to exit sleep current | This parameter is sampled | 0 | | ns |

Sleep Mode

The ZZ input pin is an asynchronous input. Asserting ZZ places the SRAM in a power conservation sleep mode. Two clock cycles are required to enter into or exit from this sleep mode. While in this mode, data integrity is guaranteed. Accesses pending when entering the sleep mode are not considered valid nor is the completion of the operation guaranteed. The device must be deselected prior to entering the sleep mode. CE_1 , CE_2 , $\overline{\text{CE}}_3$ [2], $\overline{\text{ADSP}}$, and $\overline{\text{ADSC}}$ must remain inactive for the duration of t_{ZZREC} after the ZZ input returns LOW.

Interleaved Burst Address Table (MODE = Floating or V_{DD})

| First Address A1: A0 | Second Address A1: A0 | Third Address A1: A0 | Fourth Address A1: A0 |
|-------------------------|--------------------------|-------------------------|--------------------------|
| 00 | 01 | 10 | 11 |
| 01 | 00 | 11 | 10 |
| 10 | 11 | 00 | 01 |
| 11 | 10 | 01 | 00 |

Linear Burst Address Table (MODE = GND)

| First Address A1: A0 | Second Address A1: A0 | Third Address A1: A0 | Fourth Address A1: A0 |
|-------------------------|--------------------------|-------------------------|--------------------------|
| 00 | 01 | 10 | 11 |
| 01 | 10 | 11 | 00 |
| 10 | 11 | 00 | 01 |
| 11 | 00 | 01 | 10 |



Truth Table [4, 5, 6, 7, 8]

| Cycle Description | ADDRESS Used | \overline{CE}_1 | CE_2 | \overline{CE}_3 | ZZ | \overline{ADSP} | \overline{ADSC} | \overline{ADV} | \overline{WRITE} | \overline{OE} | CLK | DQ |
|------------------------------|--------------|-------------------|--------|-------------------|----|-------------------|-------------------|------------------|--------------------|-----------------|-----|-----------|
| Deselected Cycle, Power Down | None | H | X | X | L | X | L | X | X | X | L-H | Tri-State |
| Deselected Cycle, Power Down | None | L | L | X | L | L | X | X | X | X | L-H | Tri-State |
| Deselected Cycle, Power Down | None | L | X | H | L | L | X | X | X | X | L-H | Tri-State |
| Deselected Cycle, Power Down | None | L | L | X | L | H | L | X | X | X | L-H | Tri-State |
| Deselected Cycle, Power Down | None | X | X | X | L | H | L | X | X | X | L-H | Tri-State |
| Sleep Mode, Power Down | None | X | X | X | H | X | X | X | X | X | X | Tri-State |
| Read Cycle, Begin Burst | External | L | H | L | L | L | X | X | X | L | L-H | Q |
| Read Cycle, Begin Burst | External | L | H | L | L | L | X | X | X | H | L-H | Tri-State |
| Write Cycle, Begin Burst | External | L | H | L | L | H | L | X | L | X | L-H | D |
| Read Cycle, Begin Burst | External | L | H | L | L | H | L | X | H | L | L-H | Q |
| Read Cycle, Begin Burst | External | L | H | L | L | H | L | X | H | H | L-H | Tri-State |
| Read Cycle, Continue Burst | Next | X | X | X | L | H | H | L | H | L | L-H | Q |
| Read Cycle, Continue Burst | Next | X | X | X | L | H | H | L | H | H | L-H | Tri-State |
| Read Cycle, Continue Burst | Next | H | X | X | L | X | H | L | H | L | L-H | Q |
| Read Cycle, Continue Burst | Next | H | X | X | L | X | H | L | H | H | L-H | Tri-State |
| Write Cycle, Continue Burst | Next | X | X | X | L | H | H | L | L | X | L-H | D |
| Write Cycle, Continue Burst | Next | H | X | X | L | X | H | L | L | X | L-H | D |
| Read Cycle, Suspend Burst | Current | X | X | X | L | H | H | H | H | L | L-H | Q |
| Read Cycle, Suspend Burst | Current | X | X | X | L | H | H | H | H | H | L-H | Tri-State |
| Read Cycle, Suspend Burst | Current | H | X | X | L | X | H | H | H | L | L-H | Q |
| Read Cycle, Suspend Burst | Current | H | X | X | L | X | H | H | H | H | L-H | Tri-State |
| Write Cycle, Suspend Burst | Current | X | X | X | L | H | H | H | L | X | L-H | D |
| Write Cycle, Suspend Burst | Current | H | X | X | L | X | H | H | L | X | L-H | D |

Notes:

4. X=Don't Care, H = Logic HIGH, L = Logic LOW.
5. \overline{WRITE} = L when any one or more byte write enable signals, and \overline{BWE} = L or \overline{GW} = L. \overline{WRITE} = H when all byte write enable signals, \overline{BWE} , \overline{GW} = H.
6. The DQ pins are controlled by the current cycle and the \overline{OE} signal. \overline{OE} is asynchronous and is not sampled with the clock.
7. The SRAM always initiates a read cycle when \overline{ADSP} is asserted, regardless of the state of \overline{GW} , \overline{BWE} , or \overline{BW} . Writes may occur only on subsequent clocks after the \overline{ADSP} or with the assertion of \overline{ADSC} . As a result, \overline{OE} must be driven HIGH prior to the start of the write cycle to allow the outputs to tri-state. \overline{OE} is a don't care for the remainder of the write cycle.
8. \overline{OE} is asynchronous and is not sampled with the clock rise. It is masked internally during write cycles. During a read cycle all data bits are tri-state when \overline{OE} is inactive or when the device is deselected, and all data bits behave as output when \overline{OE} is active (LOW).

Truth Table for Read/Write [4, 9]

| Function (CY7C1381D/CY7C1381F) | \overline{GW} | \overline{BWE} | \overline{BW}_D | \overline{BW}_C | \overline{BW}_B | \overline{BW}_A |
|---|-----------------|------------------|-------------------|-------------------|-------------------|-------------------|
| Read | H | H | X | X | X | X |
| Read | H | L | H | H | H | H |
| Write Byte A (DQ _A , DQP _A) | H | L | H | H | H | L |
| Write Byte B (DQ _B , DQP _B) | H | L | H | H | L | H |
| Write Bytes A, B (DQ _A , DQ _B , DQP _A , DQP _B) | H | L | H | H | L | L |
| Write Byte C (DQ _C , DQP _C) | H | L | H | L | H | H |
| Write Bytes C, A (DQ _C , DQ _A , DQP _C , DQP _A) | H | L | H | L | H | L |
| Write Bytes C, B (DQ _C , DQ _B , DQP _C , DQP _B) | H | L | H | L | L | H |
| Write Bytes C, B, A (DQ _C , DQ _B , DQ _A , DQP _C , DQP _B , DQP _A) | H | L | H | L | L | L |
| Write Byte D (DQ _D , DQP _D) | H | L | L | H | H | H |
| Write Bytes D, A (DQ _D , DQ _A , DQP _D , DQP _A) | H | L | L | H | H | L |
| Write Bytes D, B (DQ _D , DQ _B , DQP _D , DQP _B) | H | L | L | H | L | H |
| Write Bytes D, B, A (DQ _D , DQ _B , DQ _A , DQP _D , DQP _B , DQP _A) | H | L | L | H | L | L |
| Write Bytes D, B (DQ _D , DQ _B , DQP _D , DQP _B) | H | L | L | L | H | H |
| Write Bytes D, B, A (DQ _D , DQ _C , DQ _A , DQP _D , DQP _C , DQP _A) | H | L | L | L | H | L |

Truth Table for Read/Write [4, 9]

| Function (CY7C1383D/CY7C1383F) | \overline{GW} | \overline{BWE} | \overline{BW}_B | \overline{BW}_A |
|---|-----------------|------------------|-------------------|-------------------|
| Write Bytes D, C, A (DQ _D , DQ _B , DQ _A , DQP _D , DQP _B , DQP _A) | H | L | L | L |
| Write All Bytes | H | L | L | L |
| Write All Bytes | L | X | X | X |
| Read | H | H | X | X |
| Read | H | L | H | H |
| Write Byte A – (DQ _A and DQP _A) | H | L | H | L |
| Write Byte B – (DQ _B and DQP _B) | H | L | L | H |
| Write All Bytes | H | L | L | L |
| Write All Bytes | L | X | X | X |

Note:

 9. Table only lists a partial listing of the byte write combinations. Any combination of \overline{BW}_X is valid. Appropriate write will be done based on which byte write is active.

IEEE 1149.1 Serial Boundary Scan (JTAG)

The CY7C1381D/CY7C1383D/CY7C1381F/CY7C1383F incorporates a serial boundary scan test access port (TAP). This part is fully compliant with 1149.1. The TAP operates using JEDEC-standard 3.3V or 2.5V IO logic levels.

The CY7C1381D/CY7C1383D/CY7C1381F/CY7C1383F contains a TAP controller, instruction register, boundary scan register, bypass register, and ID register.

Disabling the JTAG Feature

It is possible to operate the SRAM without using the JTAG feature. To disable the TAP controller, TCK must be tied LOW (V_{SS}) to prevent clocking of the device. TDI and TMS are internally pulled up and may be unconnected. They may alternately be connected to V_{DD} through a pull up resistor. TDO may be left unconnected. Upon power up, the device will come up in a reset state, which will not interfere with the operation of the device.

TAP Controller State Diagram

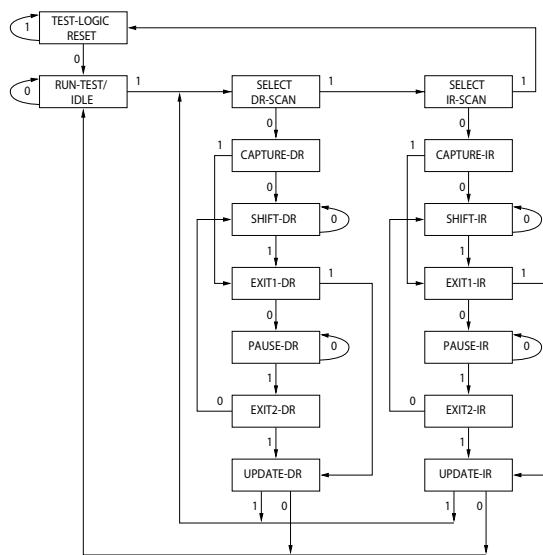

The 0 or 1 next to each state represents the value of TMS at the rising edge of TCK.

Test Access Port (TAP)

Test Clock (TCK)

The test clock is used only with the TAP controller. All inputs are captured on the rising edge of TCK. All outputs are driven from the falling edge of TCK.

Test MODE SELECT (TMS)

The TMS input is used to give commands to the TAP controller and is sampled on the rising edge of TCK. This pin may be left unconnected if the TAP is not used. The ball is pulled up internally, resulting in a logic HIGH level.

Test Data-In (TDI)

The TDI ball is used to serially input information into the registers and can be connected to the input of any of the

registers. The register between TDI and TDO is chosen by the instruction that is loaded into the TAP instruction register. TDI is internally pulled up and can be unconnected if the TAP is unused in an application. TDI is connected to the most significant bit (MSB) of any register. (See [TAP Controller Block Diagram](#).)

Test Data-Out (TDO)

The TDO output ball is used to serially clock data-out from the registers. The output is active depending upon the current state of the TAP state machine. The output changes on the falling edge of TCK. TDO is connected to the least significant bit (LSB) of any register. (See [TAP Controller State Diagram](#).)

TAP Controller Block Diagram

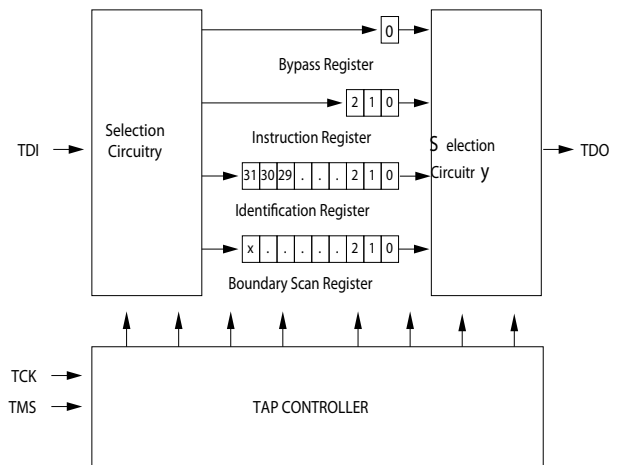

Performing a TAP Reset

A Reset is performed by forcing TMS HIGH (V_{DD}) for five rising edges of TCK. This Reset does not affect the operation of the SRAM and may be performed while the SRAM is operating. At power up, the TAP is reset internally to ensure that TDO comes up in a High-Z state.

TAP Registers

Registers are connected between the TDI and TDO balls and allow data to be scanned in and out of the SRAM test circuitry. Only one register can be selected at a time through the instruction registers. Data is serially loaded into the TDI ball on the rising edge of TCK. Data is output on the TDO ball on the falling edge of TCK.

Instruction Register

Three-bit instructions can be serially loaded into the instruction register. This register is loaded when it is placed between the TDI and TDO balls as shown in the [TAP Controller Block Diagram](#). Upon power up, the instruction register is loaded with the IDCODE instruction. It is also loaded with the IDCODE instruction if the controller is placed in a reset state as described in the previous section.

When the TAP controller is in the Capture-IR state, the two least significant bits are loaded with a binary '01' pattern to allow for fault isolation of the board level serial test path.

Bypass Register

To save time when serially shifting data through registers, it is sometimes advantageous to skip certain chips. The bypass register is a single-bit register that can be placed between the TDI and TDO balls. This allows data to be shifted through the SRAM with minimal delay. The bypass register is set LOW (V_{SS}) when the BYPASS instruction is executed.

Boundary Scan Register

The boundary scan register is connected to all the input and bidirectional balls on the SRAM.

The boundary scan register is loaded with the contents of the RAM input and output ring when the TAP controller is in the Capture-DR state and is then placed between the TDI and TDO balls when the controller is moved to the Shift-DR state. The EXTEST, SAMPLE/PRELOAD, and SAMPLE Z instructions can be used to capture the contents of the input and output ring.

The boundary scan order tables show the order in which the bits are connected. Each bit corresponds to one of the bumps on the SRAM package. The MSB of the register is connected to TDI, and the LSB is connected to TDO.

Identification (ID) Register

The ID register is loaded with a vendor-specific 32-bit code during the Capture-DR state when the IDCODE command is loaded in the instruction register. The IDCODE is hardwired into the SRAM and can be shifted out when the TAP controller is in the Shift-DR state. The ID register has a vendor code and other information described in [Identification Register Definitions on page 15](#).

TAP Instruction Set

Overview

Eight different instructions are possible with the three bit instruction register. All combinations are listed in [Identification Codes on page 15](#). Three of these instructions are listed as RESERVED and must not be used. The other five instructions are described in detail below.

Instructions are loaded into the TAP controller during the Shift-IR state, when the instruction register is placed between TDI and TDO. During this state, instructions are shifted through the instruction register through the TDI and TDO balls. To execute the instruction once it is shifted in, the TAP controller needs to be moved into the Update-IR state.

EXTEST

The EXTEST instruction enables the preloaded data to be driven out through the system output pins. This instruction also selects the boundary scan register to be connected for serial access between the TDI and TDO in the Shift-DR controller state.

IDCODE

The IDCODE instruction causes a vendor-specific 32-bit code to be loaded into the instruction register. It also places the instruction register between the TDI and TDO balls and allows the IDCODE to be shifted out of the device when the TAP controller enters the Shift-DR state.

The IDCODE instruction is loaded into the instruction register upon power up or whenever the TAP controller is given a test logic reset state.

SAMPLE Z

The SAMPLE Z instruction causes the boundary scan register to be connected between the TDI and TDO balls when the TAP controller is in a Shift-DR state. The SAMPLE Z command places all SRAM outputs into a High-Z state.

SAMPLE/PRELOAD

SAMPLE/PRELOAD is a 1149.1 mandatory instruction. When the SAMPLE/PRELOAD instructions are loaded into the instruction register and the TAP controller is in the Capture-DR state, a snapshot of data on the inputs and output pins is captured in the boundary scan register.

The user must be aware that the TAP controller clock can only operate at a frequency up to 20 MHz, while the SRAM clock operates more than an order of magnitude faster. Because there is a large difference in the clock frequencies, it is possible that during the Capture-DR state, an input or output will undergo a transition. The TAP may then try to capture a signal while in transition (metastable state). This will not harm the device, but there is no guarantee as to the value that will be captured. Repeatable results may not be possible.

To guarantee that the boundary scan register will capture the correct value of a signal, the SRAM signal must be stabilized long enough to meet the TAP controller's capture setup plus hold times (t_{CS} and t_{CH}). The SRAM clock input might not be captured correctly if there is no way in a design to stop (or slow) the clock during a SAMPLE/PRELOAD instruction. If this is an issue, it is still possible to capture all other signals and simply ignore the value of the CK and CK captured in the boundary scan register.

Once the data is captured, it is possible to shift out the data by putting the TAP into the Shift-DR state. This places the boundary scan register between the TDI and TDO pins.

PRELOAD allows an initial data pattern to be placed at the latched parallel outputs of the boundary scan register cells prior to the selection of another boundary scan test operation.

The shifting of data for the SAMPLE and PRELOAD phases can occur concurrently when required; that is, while data captured is shifted out, the preloaded data is shifted in.

BYPASS

When the BYPASS instruction is loaded in the instruction register and the TAP is placed in a Shift-DR state, the bypass register is placed between the TDI and TDO balls. The advantage of the BYPASS instruction is that it shortens the boundary scan path when multiple devices are connected together on a board.

EXTEST Output Bus Tri-State

IEEE standard 1149.1 mandates that the TAP controller be able to put the output bus into a tri-state mode.

The boundary scan register has a special bit located at bit #85 (for 119-BGA package) or bit #89 (for 165-fBGA package). When this scan cell, called the "extest output bus tri-state," is latched into the preload register during the Update-DR state in the TAP controller, it will directly control the state of the output

(Q-bus) pins, when the EXTEST is entered as the current instruction. When HIGH, it will enable the output buffers to drive the output bus. When LOW, this bit will place the output bus into a High-Z condition.

This bit can be set by entering the SAMPLE/PRELOAD or EXTEST command, and then shifting the desired bit into that cell, during the Shift-DR state. During Update-DR, the value loaded into that shift-register cell will latch into the preload register. When the EXTEST instruction is entered, this bit will

directly control the output Q-bus pins. Note that this bit is preset HIGH to enable the output when the device is powered up, and also when the TAP controller is in the Test-Logic-Reset state.

Reserved

These instructions are not implemented but are reserved for future use. Do not use these instructions.

TAP Timing

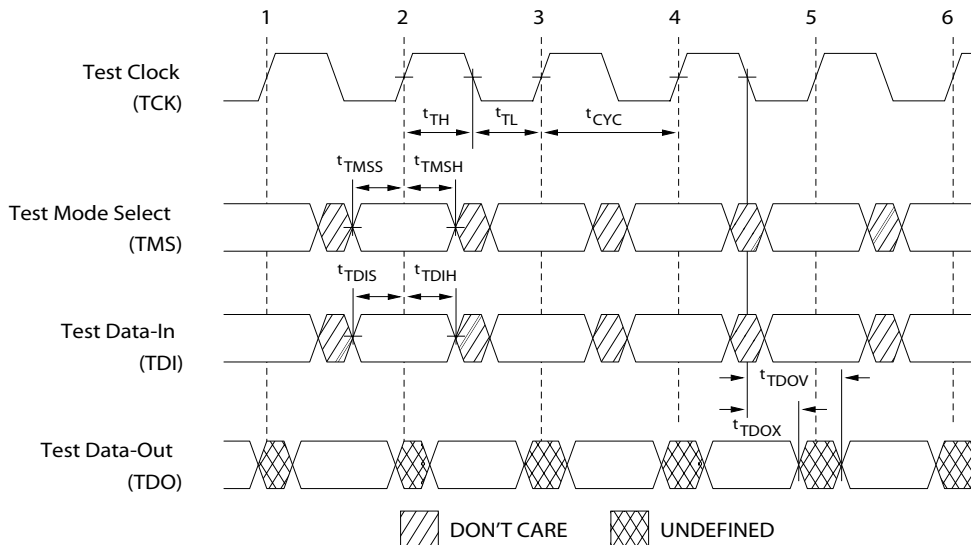

TAP AC Switching Characteristics

Over the Operating Range ^[10, 11]

| Parameter | Description | Min | Max | Unit |
|---------------------|-------------------------------|-----|-----|------|
| Clock | | | | |
| t_{TCYC} | TCK Clock Cycle Time | 50 | | ns |
| t_{TF} | TCK Clock Frequency | | 20 | MHz |
| t_{TH} | TCK Clock HIGH time | 20 | | ns |
| t_{TL} | TCK Clock LOW time | 20 | | ns |
| Output Times | | | | |
| t_{TDOV} | TCK Clock LOW to TDO Valid | | 10 | ns |
| t_{TDOX} | TCK Clock LOW to TDO Invalid | 0 | | ns |
| Setup Times | | | | |
| t_{TMSS} | TMS Setup to TCK Clock Rise | 5 | | ns |
| t_{TDIS} | TDI Setup to TCK Clock Rise | 5 | | ns |
| t_{CS} | Capture Setup to TCK Rise | 5 | | ns |
| Hold Times | | | | |
| t_{TMSH} | TMS Hold after TCK Clock Rise | 5 | | ns |
| t_{TDIH} | TDI Hold after Clock Rise | 5 | | ns |
| t_{CH} | Capture Hold after Clock Rise | 5 | | ns |

Notes:

10. t_{CS} and t_{CH} refer to the setup and hold time requirements of latching data from the boundary scan register.
 11. Test conditions are specified using the load in TAP AC test conditions. $t_R/t_F = 1$ ns.

3.3V TAP AC Test Conditions

Input pulse levels V_{SS} to 3.3V
 Input rise and fall times 1 ns
 Input timing reference levels 1.5V
 Output reference levels 1.5V
 Test load termination supply voltage 1.5V

2.5V TAP AC Test Conditions

Input pulse levels V_{SS} to 2.5V
 Input rise and fall time 1 ns
 Input timing reference levels 1.25V
 Output reference levels 1.25V
 Test load termination supply voltage 1.25V

3.3V TAP AC Output Load Equivalent

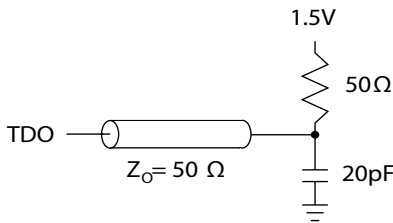

2.5V TAP AC Output Load Equivalent

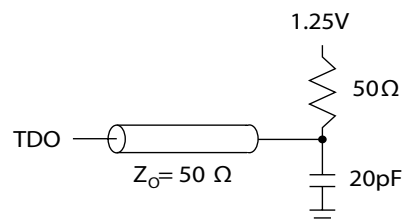

TAP DC Electrical Characteristics And Operating Conditions

(0°C < TA < +70°C; $V_{DD} = 3.3V \pm 0.165V$ unless otherwise noted) [12]

| Parameter | Description | Conditions | Min | Max | Unit |
|------------------|---------------------|---|------|----------------|---------------|
| V _{OH1} | Output HIGH Voltage | $I_{OH} = -4.0 \text{ mA}$ $V_{DDQ} = 3.3V$ | 2.4 | | V |
| | | $I_{OH} = -1.0 \text{ mA}$ $V_{DDQ} = 2.5V$ | 2.0 | | V |
| V _{OH2} | Output HIGH Voltage | $I_{OH} = -100 \mu\text{A}$ $V_{DDQ} = 3.3V$ | 2.9 | | V |
| | | $V_{DDQ} = 2.5V$ | 2.1 | | V |
| V _{OL1} | Output LOW Voltage | $I_{OL} = 8.0 \text{ mA}$ $V_{DDQ} = 3.3V$ | | 0.4 | V |
| | | $I_{OL} = 8.0 \text{ mA}$ $V_{DDQ} = 2.5V$ | | 0.4 | V |
| V _{OL2} | Output LOW Voltage | $I_{OL} = 100 \mu\text{A}$ $V_{DDQ} = 3.3V$ | | 0.2 | V |
| | | $V_{DDQ} = 2.5V$ | | 0.2 | V |
| V _{IH} | Input HIGH Voltage | $V_{DDQ} = 3.3V$ | 2.0 | $V_{DD} + 0.3$ | V |
| | | $V_{DDQ} = 2.5V$ | 1.7 | $V_{DD} + 0.3$ | V |
| V _{IL} | Input LOW Voltage | $V_{DDQ} = 3.3V$ | -0.3 | 0.8 | V |
| | | $V_{DDQ} = 2.5V$ | -0.3 | 0.7 | V |
| I _X | Input Load Current | $GND \leq V_{IN} \leq V_{DDQ}$ | -5 | 5 | μA |

Note:
 12. All voltages referenced to V_{SS} (GND).



Identification Register Definitions

| Instruction Field | CY7C1381D/CY7C1381F (512K × 36) | CY7C1383D/CY7C1383F (1M × 18) | Description |
|--------------------------------------|------------------------------------|----------------------------------|--|
| Revision Number (31:29) | 000 | 000 | Describes the version number. |
| Device Depth (28:24) ^[13] | 01011 | 01011 | Reserved for internal use. |
| Device Width (23:18) 119-BGA | 101001 | 101001 | Defines the memory type and architecture. |
| Device Width (23:18) 165-FBGA | 000001 | 000001 | Defines the memory type and architecture. |
| Cypress Device ID (17:12) | 100101 | 010101 | Defines the width and density. |
| Cypress JEDEC ID Code (11:1) | 00000110100 | 00000110100 | Allows unique identification of SRAM vendor. |
| ID Register Presence Indicator (0) | 1 | 1 | Indicates the presence of an ID register. |

Scan Register Sizes

| Register Name | Bit Size (×36) | Bit Size (×18) |
|---|----------------|----------------|
| Instruction Bypass | 3 | 3 |
| Bypass | 1 | 1 |
| ID | 32 | 32 |
| Boundary Scan Order (119-ball BGA package) | 85 | 85 |
| Boundary Scan Order (165-ball fBGA package) | 89 | 89 |

Identification Codes

| Instruction | Code | Description |
|----------------|------|---|
| EXTEST | 000 | Captures Input/Output ring contents. Places the boundary scan register between TDI and TDO. Forces all SRAM outputs to High-Z state. |
| IDCODE | 001 | Loads the ID register with the vendor ID code and places the register between TDI and TDO. This operation does not affect SRAM operations. |
| SAMPLE Z | 010 | Captures Input/Output ring contents. Places the boundary scan register between TDI and TDO. Forces all SRAM output drivers to a High-Z state. |
| RESERVED | 011 | Do Not Use. This instruction is reserved for future use. |
| SAMPLE/PRELOAD | 100 | Captures Input/Output ring contents. Places the boundary scan register between TDI and TDO. Does not affect SRAM operation. |
| RESERVED | 101 | Do Not Use. This instruction is reserved for future use. |
| RESERVED | 110 | Do Not Use. This instruction is reserved for future use. |
| BYPASS | 111 | Places the bypass register between TDI and TDO. This operation does not affect SRAM operations. |

Note:
13. Bit #24 is "1" in the register definitions for both 2.5V and 3.3V versions of this device.



119-Ball BGA Boundary Scan Order ^[14, 15]

| Bit # | Ball ID | Bit # | Ball ID | Bit # | Ball ID | Bit # | Ball ID |
|-------|---------|-------|---------|-------|---------|-------|----------|
| 1 | H4 | 23 | F6 | 45 | G4 | 67 | L1 |
| 2 | T4 | 24 | E7 | 46 | A4 | 68 | M2 |
| 3 | T5 | 25 | D7 | 47 | G3 | 69 | N1 |
| 4 | T6 | 26 | H7 | 48 | C3 | 70 | P1 |
| 5 | R5 | 27 | G6 | 49 | B2 | 71 | K1 |
| 6 | L5 | 28 | E6 | 50 | B3 | 72 | L2 |
| 7 | R6 | 29 | D6 | 51 | A3 | 73 | N2 |
| 8 | U6 | 30 | C7 | 52 | C2 | 74 | P2 |
| 9 | R7 | 31 | B7 | 53 | A2 | 75 | R3 |
| 10 | T7 | 32 | C6 | 54 | B1 | 76 | T1 |
| 11 | P6 | 33 | A6 | 55 | C1 | 77 | R1 |
| 12 | N7 | 34 | C5 | 56 | D2 | 78 | T2 |
| 13 | M6 | 35 | B5 | 57 | E1 | 79 | L3 |
| 14 | L7 | 36 | G5 | 58 | F2 | 80 | R2 |
| 15 | K6 | 37 | B6 | 59 | G1 | 81 | T3 |
| 16 | P7 | 38 | D4 | 60 | H2 | 82 | L4 |
| 17 | N6 | 39 | B4 | 61 | D1 | 83 | N4 |
| 18 | L6 | 40 | F4 | 62 | E2 | 84 | P4 |
| 19 | K7 | 41 | M4 | 63 | G2 | 85 | Internal |
| 20 | J5 | 42 | A5 | 64 | H1 | | |
| 21 | H6 | 43 | K4 | 65 | J3 | | |
| 22 | G7 | 44 | E4 | 66 | 2K | | |

Notes:

- 14. Balls which are NC (No Connect) are pre-set LOW.
- 15. Bit# 85 is pre-set HIGH.



165-Ball BGA Boundary Scan Order ^[14, 16]

| Bit # | Ball ID |
|-------|---------|
| 1 | N6 |
| 2 | N7 |
| 3 | N10 |
| 4 | P11 |
| 5 | P8 |
| 6 | R8 |
| 7 | R9 |
| 8 | P9 |
| 9 | P10 |
| 10 | R10 |
| 11 | R11 |
| 12 | H11 |
| 13 | N11 |
| 14 | M11 |
| 15 | L11 |
| 16 | K11 |
| 17 | J11 |
| 18 | M10 |
| 19 | L10 |
| 20 | K10 |
| 21 | J10 |
| 22 | H9 |
| 23 | H10 |
| 24 | G11 |
| 25 | F11 |
| 26 | E11 |
| 27 | D11 |
| 28 | G10 |
| 29 | F10 |
| 30 | E10 |

| Bit # | Ball ID |
|-------|---------|
| 31 | D10 |
| 32 | C11 |
| 33 | A11 |
| 34 | B11 |
| 35 | A10 |
| 36 | B10 |
| 37 | A9 |
| 38 | B9 |
| 39 | C10 |
| 40 | A8 |
| 41 | B8 |
| 42 | A7 |
| 43 | B7 |
| 44 | B6 |
| 45 | A6 |
| 46 | B5 |
| 47 | A5 |
| 48 | A4 |
| 49 | B4 |
| 50 | B3 |
| 51 | A3 |
| 52 | A2 |
| 53 | B2 |
| 54 | C2 |
| 55 | B1 |
| 56 | A1 |
| 57 | C1 |
| 58 | D1 |
| 59 | E1 |
| 60 | F1 |

| Bit # | Ball ID |
|-------|----------|
| 61 | G1 |
| 62 | D2 |
| 63 | E2 |
| 64 | F2 |
| 65 | G2 |
| 66 | H1 |
| 67 | H3 |
| 68 | J1 |
| 69 | K1 |
| 70 | L1 |
| 71 | M1 |
| 72 | J2 |
| 73 | K2 |
| 74 | L2 |
| 75 | M2 |
| 76 | N1 |
| 77 | N2 |
| 78 | P1 |
| 79 | R1 |
| 80 | R2 |
| 81 | P3 |
| 82 | R3 |
| 83 | P2 |
| 84 | R4 |
| 85 | P4 |
| 86 | N5 |
| 87 | P6 |
| 88 | R6 |
| 89 | Internal |
| | |

Note:
16. Bit# 89 is pre-set HIGH.



Maximum Ratings

Exceeding the maximum ratings may impair the useful life of the device. For user guidelines, not tested.

- Storage Temperature -65°C to +150°C
- Ambient Temperature with Power Applied..... -55°C to +125°C
- Supply Voltage on V_{DD} Relative to GND -0.3V to +4.6V
- Supply Voltage on V_{DDQ} Relative to GND -0.3V to +V_{DD}
- DC Voltage Applied to Outputs in Tri-State..... -0.5V to V_{DDQ} + 0.5V

- DC Input Voltage -0.5V to V_{DD} + 0.5V
- Current into Outputs (LOW) 20 mA
- Static Discharge Voltage..... > 2001V (per MIL-STD-883, Method 3015)
- Latch-up Current > 200 mA

Operating Range

| Range | Ambient Temperature | V _{DD} | V _{DDQ} |
|------------|---------------------|-----------------|------------------------------|
| Commercial | 0°C to +70°C | 3.3V -5%/+10% | 2.5V - 5% to V _{DD} |
| Industrial | -40°C to +85°C | | |

Electrical Characteristics

Over the Operating Range [17, 18]

| Parameter | Description | Test Conditions | Min | Max | Unit |
|------------------|---|---|-------------------------|------------------------|------|
| V _{DD} | Power Supply Voltage | | 3.135 | 3.6 | V |
| V _{DDQ} | IO Supply Voltage | for 3.3V IO | 3.135 | V _{DD} | V |
| | | for 2.5V IO | 2.375 | 2.625 | V |
| V _{OH} | Output HIGH Voltage | for 3.3V IO, I _{OH} = -4.0 mA | 2.4 | | V |
| | | for 2.5V IO, I _{OH} = -1.0 mA | 2.0 | | V |
| V _{OL} | Output LOW Voltage | for 3.3V IO, I _{OL} = 8.0 mA | | 0.4 | V |
| | | for 2.5V IO, I _{OL} = 1.0 mA | | 0.4 | V |
| V _{IH} | Input HIGH Voltage [17] | for 3.3V IO | 2.0 | V _{DD} + 0.3V | V |
| | | for 2.5V IO | 1.7 | V _{DD} + 0.3V | V |
| V _{IL} | Input LOW Voltage [17] | for 3.3V IO | -0.3 | 0.8 | V |
| | | for 2.5V IO | -0.3 | 0.7 | V |
| I _X | Input Leakage Current except ZZ and MODE | GND ≤ V _I ≤ V _{DDQ} | -5 | 5 | μA |
| | | Input Current of MODE | Input = V _{SS} | -30 | |
| | Input Current of ZZ | Input = V _{DD} | | 5 | μA |
| | | Input = V _{SS} | -5 | | μA |
| I _{OZ} | Output Leakage Current | Input = V _{DD} | | 30 | μA |
| | | GND ≤ V _I ≤ V _{DD} , Output Disabled | -5 | 5 | μA |
| I _{DD} | V _{DD} Operating Supply Current | V _{DD} = Max, I _{OUT} = 0 mA, f = f _{MAX} = 1/t _{CYC} | 7.5-ns cycle, 133 MHz | 210 | mA |
| | | | 10-ns cycle, 100 MHz | 175 | mA |
| I _{SB1} | Automatic CE Power Down Current—TTL Inputs | Max V _{DD} , Device Deselected, V _{IN} ≥ V _{IH} or V _{IN} ≤ V _{IL} , f = f _{MAX} , inputs switching | 7.5-ns cycle, 133 MHz | 140 | mA |
| | | | 10-ns cycle, 100 MHz | 120 | |
| I _{SB2} | Automatic CE Power Down Current—CMOS Inputs | Max V _{DD} , Device Deselected, V _{IN} ≥ V _{DD} - 0.3V or V _{IN} ≤ 0.3V, f = 0, inputs static | All speeds | 70 | mA |
| I _{SB3} | Automatic CE Power Down Current—CMOS Inputs | Max V _{DD} , Device Deselected, V _{IN} ≥ V _{DDQ} - 0.3V or V _{IN} ≤ 0.3V, f = f _{MAX} , inputs switching | 7.5-ns cycle, 133 MHz | 130 | mA |
| | | | 10-ns cycle, 100 MHz | 110 | mA |
| I _{SB4} | Automatic CE Power Down Current—TTL Inputs | Max V _{DD} , Device Deselected, V _{IN} ≥ V _{DD} - 0.3V or V _{IN} ≤ 0.3V, f = 0, inputs static | All Speeds | 80 | mA |

Notes:

- 17. Overshoot: V_{IH}(AC) < V_{DD} + 1.5V (pulse width less than t_{CYC}/2), undershoot: V_{IL}(AC) > -2V (pulse width less than t_{CYC}/2).
- 18. T_{power up}: Assumes a linear ramp from 0v to V_{DD}(min) within 200 ms. During this time V_{IH} < V_{DD} and V_{DDQ} ≤ V_{DD}.

Capacitance [19]

| Parameter | Description | Test Conditions | 100 TQFP Package | 119 BGA Package | 165 FBGA Package | Unit |
|-----------|--------------------------|--|------------------|-----------------|------------------|------|
| C_{IN} | Input Capacitance | $T_A = 25^\circ\text{C}$, $f = 1\text{ MHz}$, $V_{DD} = 3.3\text{V}$, $V_{DDQ} = 2.5\text{V}$ | 5 | 8 | 9 | pF |
| C_{CLK} | Clock Input Capacitance | | 5 | 8 | 9 | pF |
| C_{IO} | Input/Output Capacitance | | 5 | 8 | 9 | pF |

Thermal Resistance [19]

| Parameter | Description | Test Conditions | 100 TQFP Package | 119 BGA Package | 165 FBGA Package | Unit |
|---------------|--|---|------------------|-----------------|------------------|--------------------|
| Θ_{JA} | Thermal Resistance (Junction to Ambient) | Test conditions follow standard test methods and procedures for measuring thermal impedance, in accordance with EIA/JESD51. | 28.66 | 23.8 | 20.7 | $^\circ\text{C/W}$ |
| Θ_{JC} | Thermal Resistance (Junction to Case) | | 4.08 | 6.2 | 4.0 | $^\circ\text{C/W}$ |

AC Test Loads and Waveforms

3.3V IO Test Load

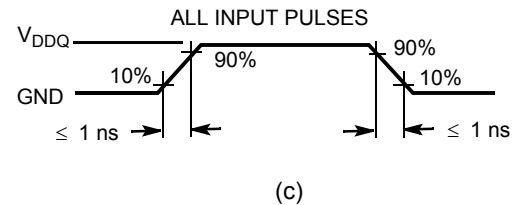
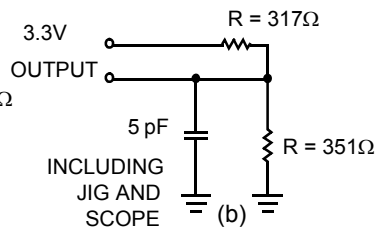
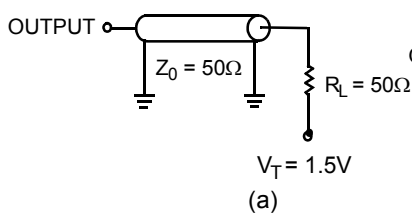

2.5V IO Test Load

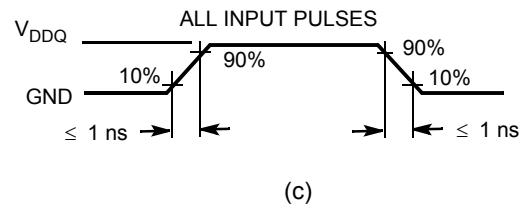
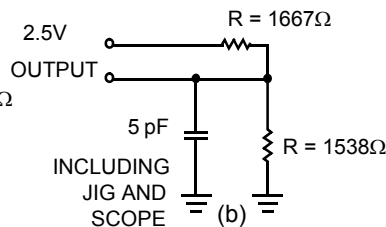
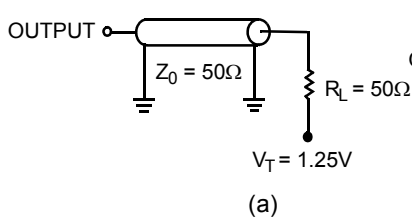

Note:
19. Tested initially and after any design or process change that may affect these parameters.



Switching Characteristics

Over the Operating Range ^[20, 21]

| Parameter | Description | 133 MHz | | 100 MHz | | Unit |
|---------------------|--|---------|-----|---------|-----|------|
| | | Min | Max | Min | Max | |
| t _{POWER} | V _{DD} (Typical) to the first Access ^[22] | 1 | | 1 | | ms |
| Clock | | | | | | |
| t _{CYC} | Clock Cycle Time | 7.5 | | 10 | | ns |
| t _{CH} | Clock HIGH | 2.1 | | 2.5 | | ns |
| t _{CL} | Clock LOW | 2.1 | | 2.5 | | ns |
| Output Times | | | | | | |
| t _{CDV} | Data Output Valid After CLK Rise | | 6.5 | | 8.5 | ns |
| t _{DOH} | Data Output Hold After CLK Rise | 2.0 | | 2.0 | | ns |
| t _{CLZ} | Clock to Low-Z ^[23, 24, 25] | 2.0 | | 2.0 | | ns |
| t _{CHZ} | Clock to High-Z ^[23, 24, 25] | 0 | 4.0 | 0 | 5.0 | ns |
| t _{OEV} | \overline{OE} LOW to Output Valid | | 3.2 | | 3.8 | ns |
| t _{OELZ} | \overline{OE} LOW to Output Low-Z ^[23, 24, 25] | 0 | | 0 | | ns |
| t _{OEHZ} | \overline{OE} HIGH to Output High-Z ^[23, 24, 25] | | 4.0 | | 5.0 | ns |
| Setup Times | | | | | | |
| t _{AS} | Address Setup Before CLK Rise | 1.5 | | 1.5 | | ns |
| t _{ADS} | \overline{ADSP} , \overline{ADSC} Setup Before CLK Rise | 1.5 | | 1.5 | | ns |
| t _{ADVS} | \overline{ADV} Setup Before CLK Rise | 1.5 | | 1.5 | | ns |
| t _{WES} | \overline{GW} , \overline{BWE} , $\overline{BW}_{[A:D]}$ Setup Before CLK Rise | 1.5 | | 1.5 | | ns |
| t _{DS} | Data Input Setup Before CLK Rise | 1.5 | | 1.5 | | ns |
| t _{CES} | Chip Enable Setup | 1.5 | | 1.5 | | ns |
| Hold Times | | | | | | |
| t _{AH} | Address Hold After CLK Rise | 0.5 | | 0.5 | | ns |
| t _{ADH} | \overline{ADSP} , \overline{ADSC} Hold After CLK Rise | 0.5 | | 0.5 | | ns |
| t _{WEH} | \overline{GW} , \overline{BWE} , $\overline{BW}_{[A:D]}$ Hold After CLK Rise | 0.5 | | 0.5 | | ns |
| t _{ADVH} | \overline{ADV} Hold After CLK Rise | 0.5 | | 0.5 | | ns |
| t _{DH} | Data Input Hold After CLK Rise | 0.5 | | 0.5 | | ns |
| t _{CEH} | Chip Enable Hold After CLK Rise | 0.5 | | 0.5 | | ns |

Notes:

20. Timing reference level is 1.5V when V_{DDQ} = 3.3V and is 1.25V when V_{DDQ} = 2.5V.

21. Test conditions shown in (a) of AC Test Loads unless otherwise noted.

22. This part has a voltage regulator internally; t_{POWER} is the time that the power needs to be supplied above V_{DD}(minimum) initially, before a read or write operation can be initiated.

23. t_{CHZ}, t_{CLZ}, t_{OELZ}, and t_{OEHZ} are specified with AC test conditions shown in part (b) of [AC Test Loads and Waveforms on page 19](#). Transition is measured ± 200 mV from steady-state voltage.

24. At any given voltage and temperature, t_{OEHZ} is less than t_{OELZ} and t_{CHZ} is less than t_{CLZ} to eliminate bus contention between SRAMs when sharing the same data bus. These specifications do not imply a bus contention condition, but reflect parameters guaranteed over worst case user conditions. Device is designed to achieve High-Z prior to Low-Z under the same system condition.

25. This parameter is sampled and not 100% tested.

Timing Diagrams

Read Cycle Timing [26]

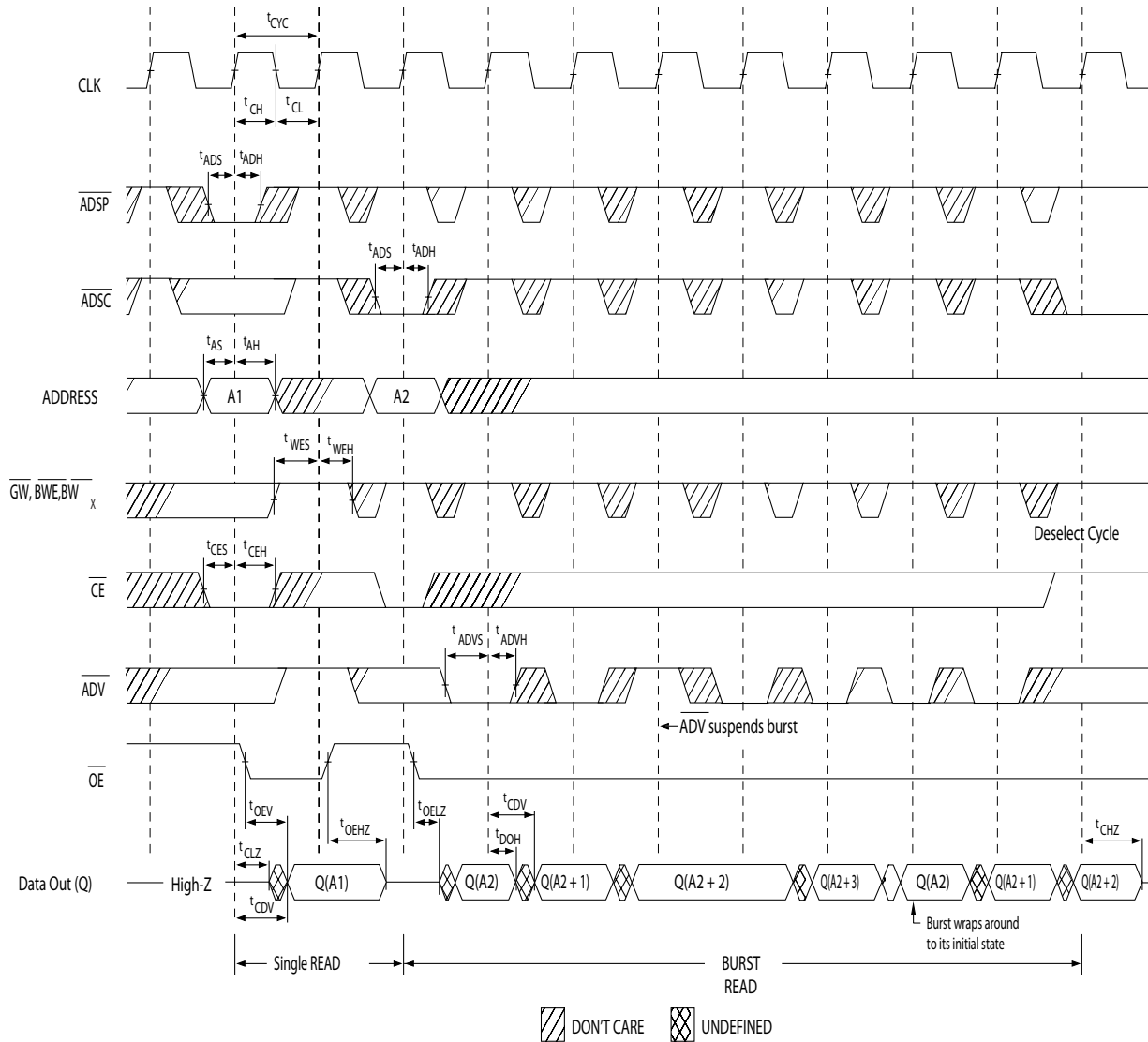

Note:

26. On this diagram, when CE is LOW: CE1 is LOW, CE2 is HIGH and CE3 is LOW. When CE is HIGH: CE1 is HIGH or CE2 is LOW or CE3 is HIGH.

Timing Diagrams (continued)

Write Cycle Timing [26, 27]

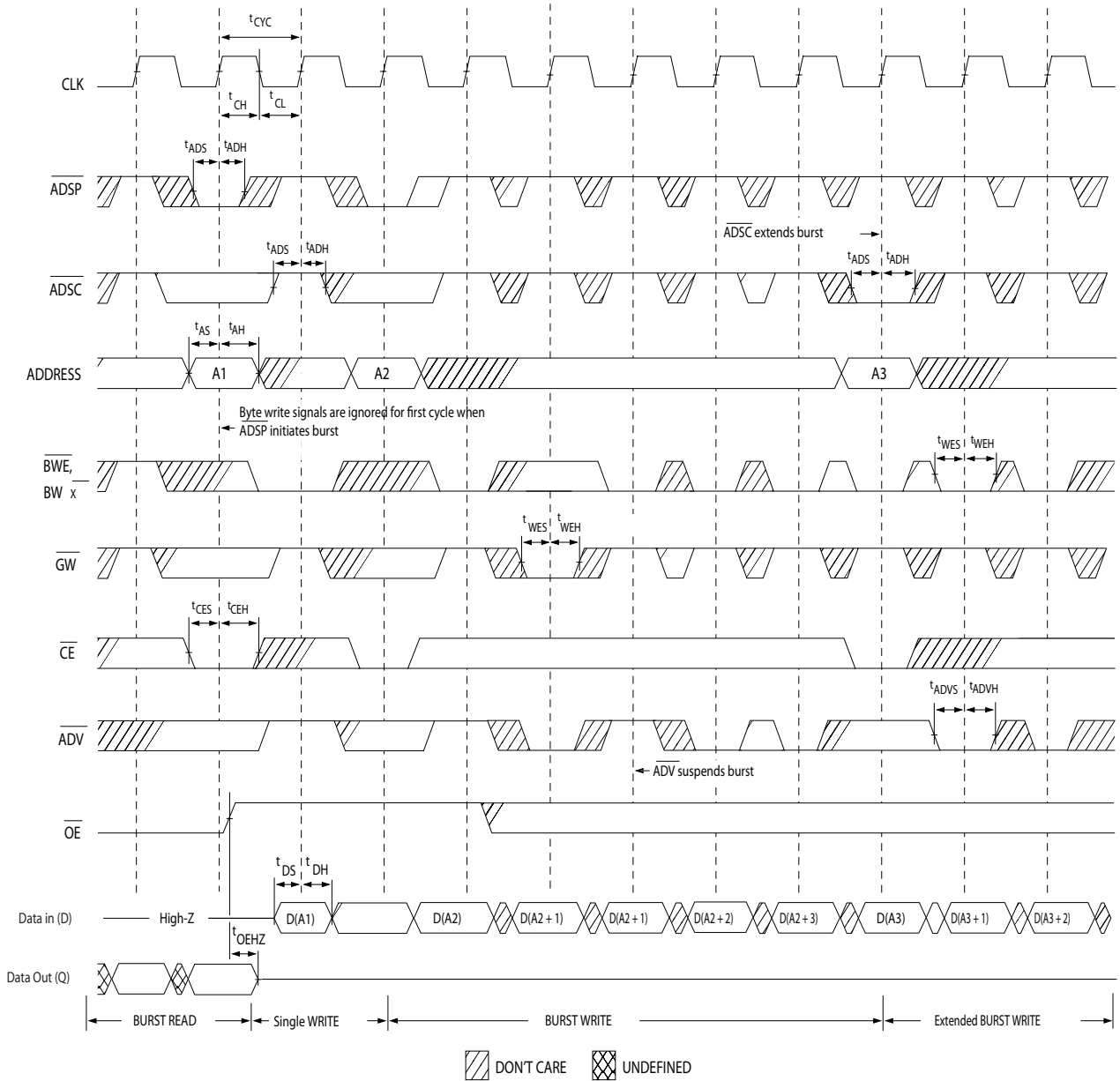

Note:
27. Full width write can be initiated by either \overline{GW} LOW; or by \overline{GW} HIGH, \overline{BWE} LOW and $\overline{BW_x}$ LOW.

Timing Diagrams (continued)

Read/Write Cycle Timing [26, 28, 29]

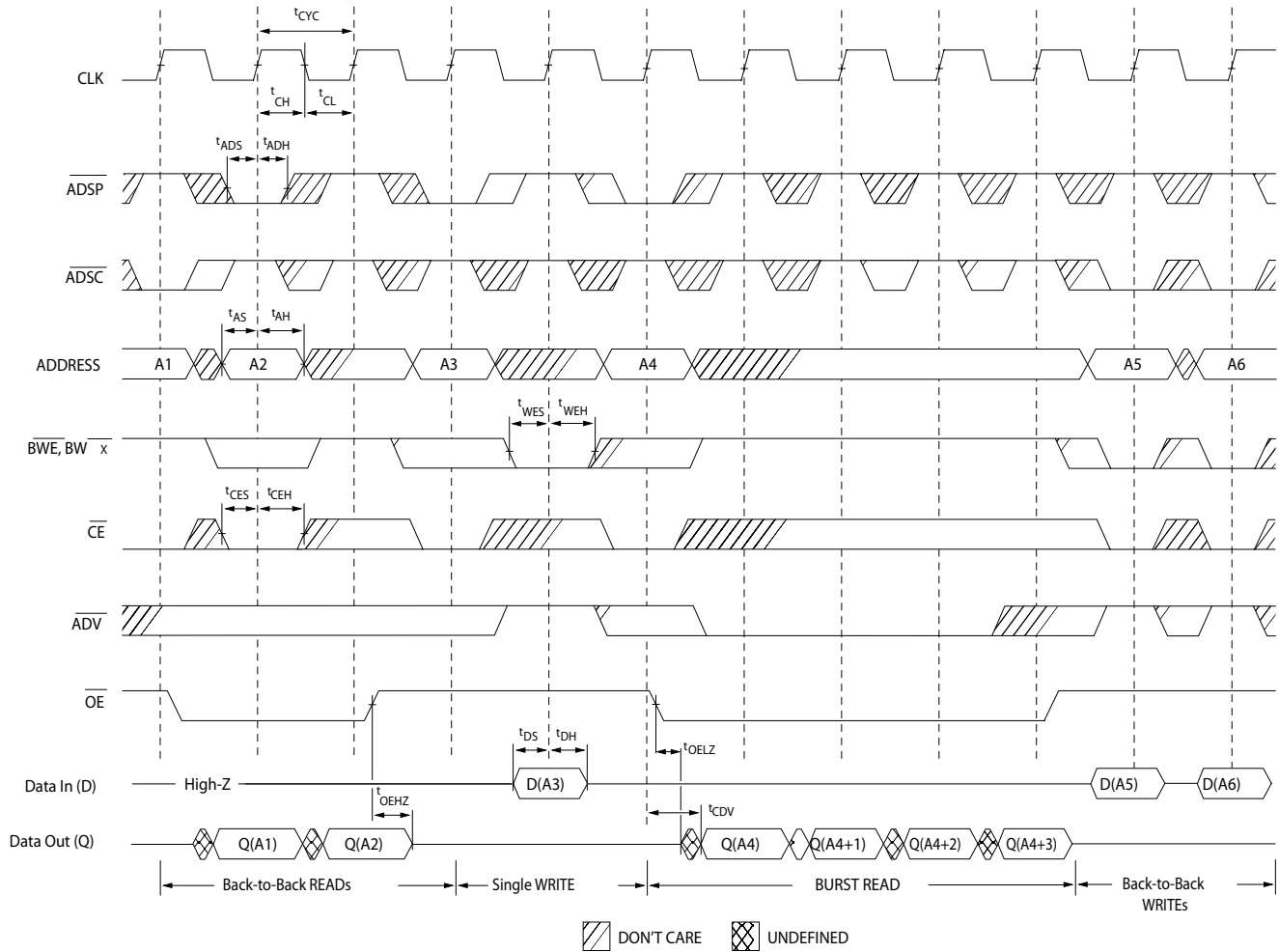

Notes:

- 28. The data bus (Q) remains in high-Z following a WRITE cycle, unless a new read access is initiated by \overline{ADSP} or \overline{ADSC} .
- 29. \overline{GW} is HIGH.

Timing Diagrams (continued)

ZZ Mode Timing [30, 31]

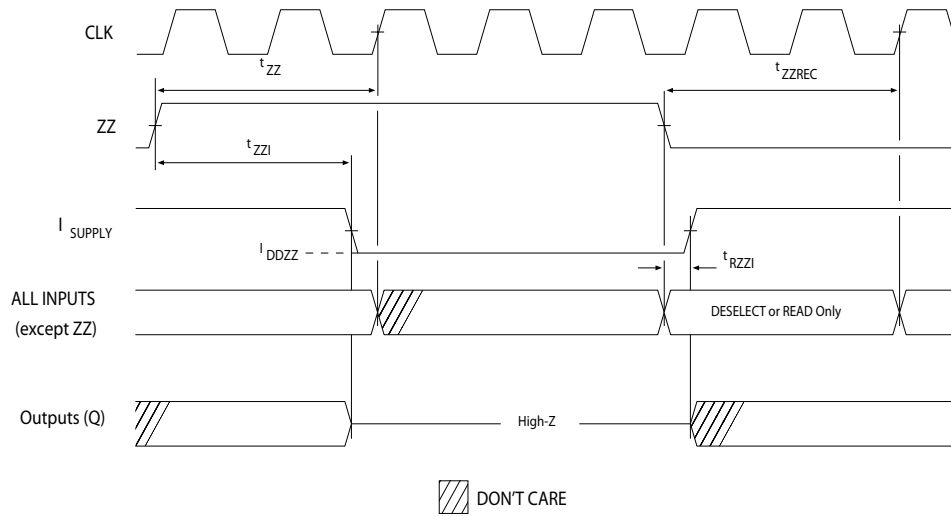

Notes:

30. Device must be deselected when entering ZZ mode. See Truth Table [4, 5, 6, 7, 8] on page 9 for all possible signal conditions to deselect the device.

31. DQs are in high-Z when exiting ZZ sleep mode.



**CY7C1381D, CY7C1381F
CY7C1383D, CY7C1383F**

Ordering Information

Not all of the speed, package and temperature ranges are available. Please contact your local sales representative or visit www.cypress.com for actual products offered.

| Speed (MHz) | Ordering Code | Package Diagram | Part and Package Type | Operating Range | |
|-------------------|-------------------|--|--|-----------------|------------|
| 133 | CY7C1381D-133AXC | 51-85050 | 100-Pin Thin Quad Flat Pack (14 x 20 x 1.4 mm) Pb-Free | Commercial | |
| | CY7C1383D-133AXC | | | | |
| | CY7C1381F-133BGC | 51-85115 | 119-ball Ball Grid Array (14 x 22 x 2.4 mm) | | |
| | CY7C1383F-133BGC | | | | |
| | CY7C1381F-133BGXC | 51-85115 | 119-ball Ball Grid Array (14 x 22 x 2.4 mm) Pb-Free | | |
| | CY7C1383F-133BGXC | | | | |
| | CY7C1381D-133BZC | 51-85180 | 165-ball Fine-Pitch Ball Grid Array (13 x 15 x 1.4 mm) | | |
| | CY7C1383D-133BZC | | | | |
| | CY7C1381D-133BZXC | 51-85180 | 165-ball Fine-Pitch Ball Grid Array (13 x 15 x 1.4 mm) Pb-Free | | |
| | CY7C1383D-133BZXC | | | | |
| | CY7C1381D-133AXI | 51-85050 | 100-Pin Thin Quad Flat Pack (14 x 20 x 1.4 mm) Pb-Free | | Industrial |
| | CY7C1383D-133AXI | | | | |
| | CY7C1381F-133BGI | 51-85115 | 119-ball Ball Grid Array (14 x 22 x 2.4 mm) | | |
| | CY7C1383F-133BGI | | | | |
| | CY7C1381F-133BGXI | 51-85115 | 119-ball Ball Grid Array (14 x 22 x 2.4 mm) Pb-Free | | |
| | CY7C1383F-133BGXI | | | | |
| CY7C1381D-133BZI | 51-85180 | 165-ball Fine-Pitch Ball Grid Array (13 x 15 x 1.4 mm) | | | |
| CY7C1383D-133BZI | | | | | |
| CY7C1381D-133BZXI | 51-85180 | 165-ball Fine-Pitch Ball Grid Array (13 x 15 x 1.4 mm) Pb-Free | | | |
| CY7C1383D-133BZXI | | | | | |
| 100 | CY7C1381D-100AXC | 51-85050 | 100-Pin Thin Quad Flat Pack (14 x 20 x 1.4 mm) Pb-Free | Commercial | |
| | CY7C1383D-100AXC | | | | |
| | CY7C1381F-100BGC | 51-85115 | 119-ball Ball Grid Array (14 x 22 x 2.4 mm) | | |
| | CY7C1383F-100BGC | | | | |
| | CY7C1381F-100BGXC | 51-85115 | 119-ball Ball Grid Array (14 x 22 x 2.4 mm) Pb-Free | | |
| | CY7C1383F-100BGXC | | | | |
| | CY7C1381D-100BZC | 51-85180 | 165-ball Fine-Pitch Ball Grid Array (13 x 15 x 1.4 mm) | | |
| | CY7C1383D-100BZC | | | | |
| | CY7C1381D-100BZXC | 51-85180 | 165-ball Fine-Pitch Ball Grid Array (13 x 15 x 1.4 mm) Pb-Free | | |
| | CY7C1383D-100BZXC | | | | |
| | CY7C1381D-100AXI | 51-85050 | 100-Pin Thin Quad Flat Pack (14 x 20 x 1.4 mm) Pb-Free | Industrial | |
| | CY7C1383D-100AXI | | | | |
| | CY7C1381F-100BGI | 51-85115 | 119-ball Ball Grid Array (14 x 22 x 2.4 mm) | | |
| | CY7C1383F-100BGI | | | | |
| | CY7C1381F-100BGXI | 51-85115 | 119-ball Ball Grid Array (14 x 22 x 2.4 mm) Pb-Free | | |
| | CY7C1383F-100BGXI | | | | |
| | CY7C1381D-100BZI | 51-85180 | 165-ball Fine-Pitch Ball Grid Array (13 x 15 x 1.4 mm) | | |
| | CY7C1383D-100BZI | | | | |
| | CY7C1381D-100BZXI | 51-85180 | 165-ball Fine-Pitch Ball Grid Array (13 x 15 x 1.4 mm) Pb-Free | | |
| | CY7C1383D-100BZXI | | | | |

Package Diagrams

Figure 1. 100-Pin Thin Plastic Quad Flat pack (14 x 20 x 1.4 mm) (51-85050)

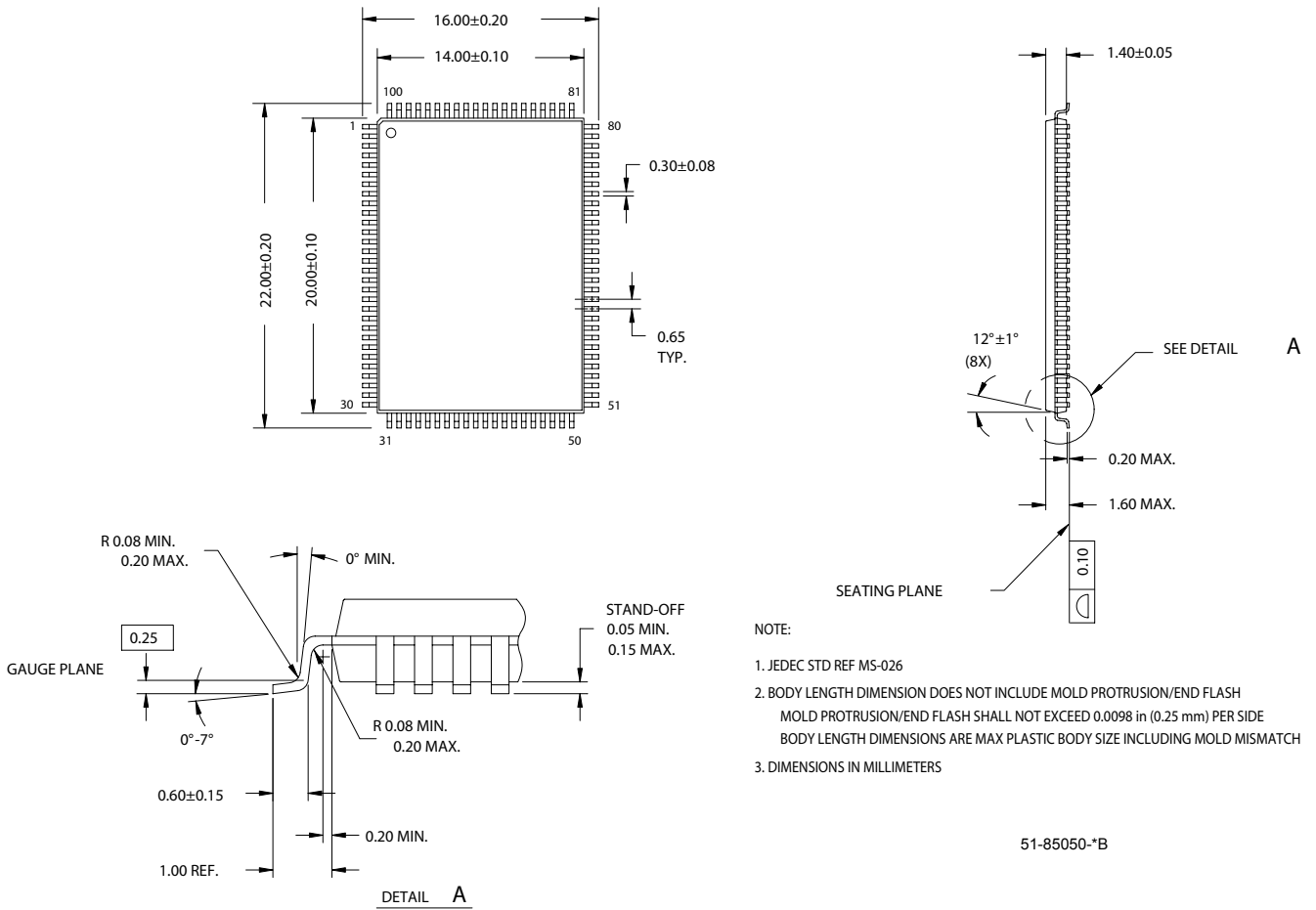

Package Diagrams (continued)

Figure 2. 119-ball BGA (14 x 22 x 2.4 mm) (51-85115)

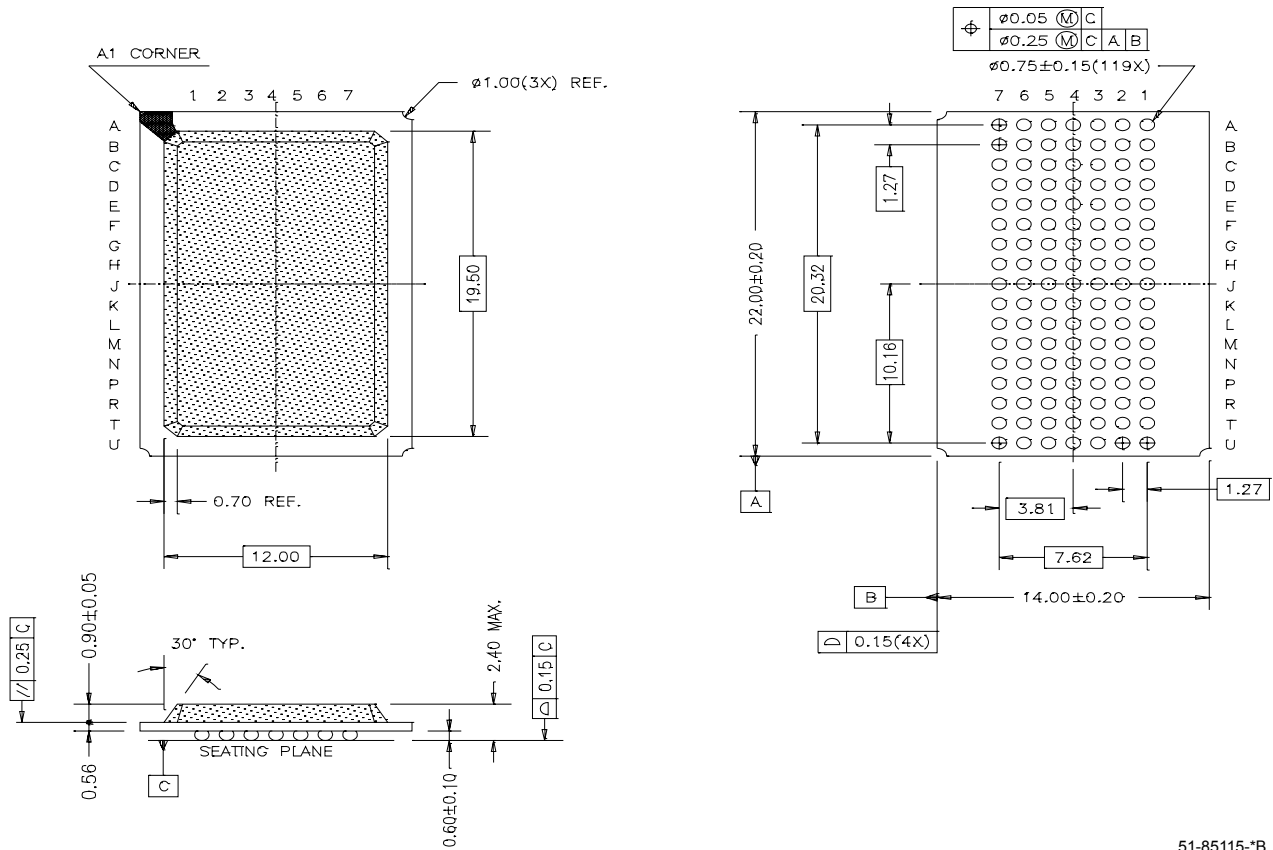

51-85115-B

Package Diagrams (continued)

Figure 3. 165-ball FBGA (13 x 15 x 1.4 mm) (51-85180)

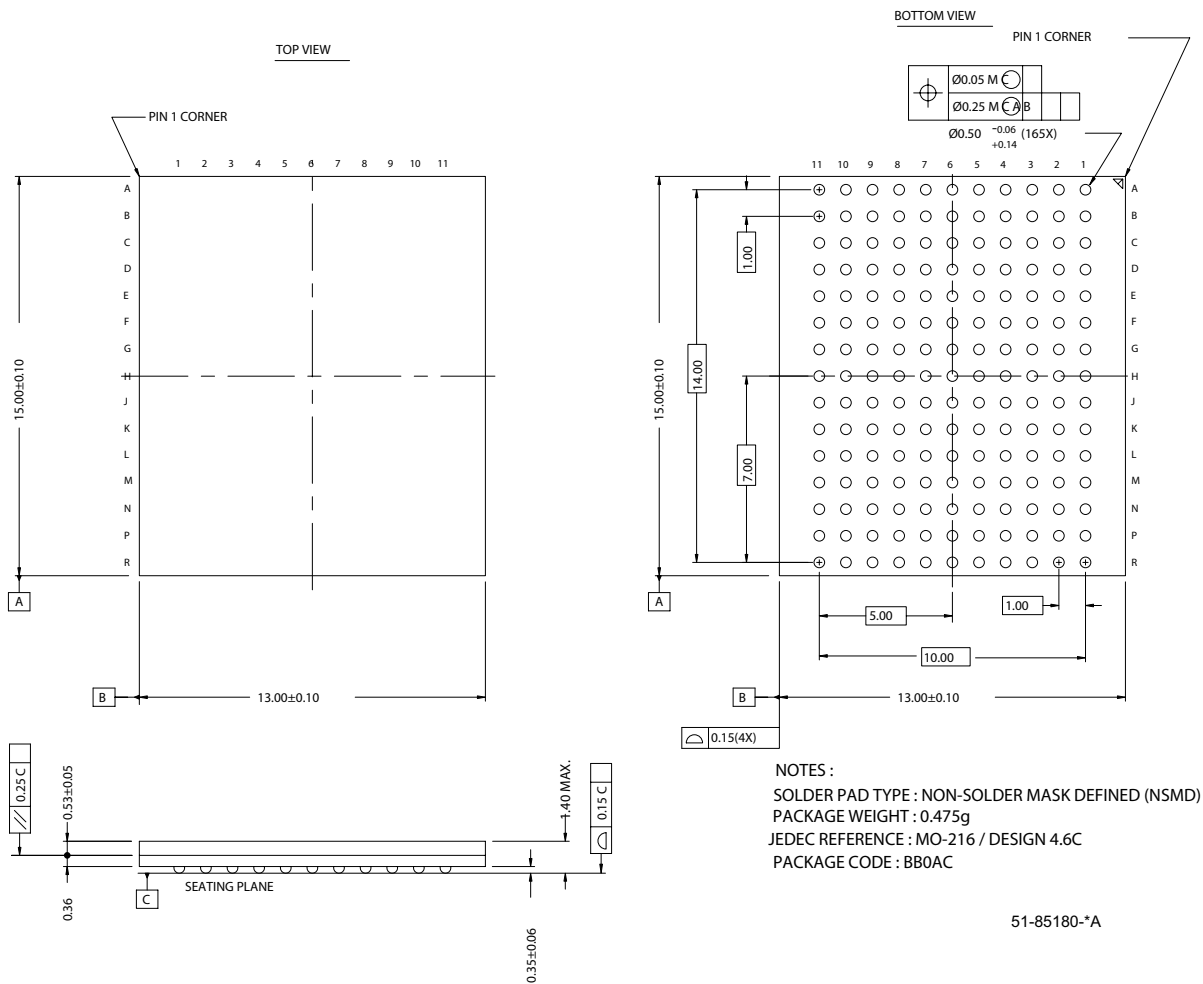

Intel and Pentium are registered trademarks, and i486 is a trademark of Intel Corporation. All product and company names mentioned in this document are the trademarks of their respective holders.



Document History Page

| Document Title: CY7C1381D/CY7C1383D/CY7C1381F/CY7C1383F 18-Mbit (512K x 36/1M x 18) Flow-Through SRAM Document Number: 38-05544 | | | | |
|--|---------|------------|-----------------|---|
| REV. | ECN NO. | Issue Date | Orig. of Change | Description of Change |
| ** | 254518 | See ECN | RKF | New data sheet |
| *A | 288531 | See ECN | SYT | Edited description under "IEEE 1149.1 Serial Boundary Scan (JTAG)" for non-compliance with 1149.1 Removed 117-MHz Speed Bin Added Pb-free information for 100-Pin TQFP, 119 BGA and 165 FBGA package Added comment of 'Pb-free BG packages availability' below the Ordering Information |
| *B | 326078 | See ECN | PCI | Address expansion pins/balls in the pinouts for all packages are modified as per JEDEC standard Added description on EXTEST Output Bus Tri-State Changed description on the Tap Instruction Set Overview and Extest Changed Device Width (23:18) for 119-BGA from 000001 to 101001 Added separate row for 165 -FBGA Device Width (23:18) Changed θ_{JA} and θ_{JC} for TQFP Package from 31 and 6 °C/W to 28.66 and 4.08 °C/W respectively Changed θ_{JA} and θ_{JC} for BGA Package from 45 and 7 °C/W to 23.8 and 6.2 °C/W respectively Changed θ_{JA} and θ_{JC} for FBGA Package from 46 and 3 °C/W to 20.7 and 4.0 °C/W respectively Modified V_{OL} , V_{OH} test conditions Removed comment of 'Pb-free BG packages availability' below the Ordering Information Updated Ordering Information Table Changed from Preliminary to Final |
| *C | 351895 | See ECN | PCI | Updated Ordering Information Table |
| *D | 416321 | See ECN | NXR | Changed address of Cypress Semiconductor Corporation on Page# 1 from "3901 North First Street" to "198 Champion Court" Changed the description of I_X from Input Load Current to Input Leakage Current on page# 18 Changed the I_X current values of MODE on page # 18 from -5 μ A and 30 μ A to -30 μ A and 5 μ A Changed the I_X current values of ZZ on page # 18 from -30 μ A and 5 μ A to -5 μ A and 30 μ A Changed $V_{IH} \leq V_{DD}$ to $V_{IH} < V_{DD}$ on page # 18 Replaced Package Name column with Package Diagram in the Ordering Information table Updated Ordering Information Table |
| *E | 475009 | See ECN | VKN | Added the Maximum Rating for Supply Voltage on V_{DDQ} Relative to GND Changed t_{TH} , t_{TL} from 25 ns to 20 ns and t_{DOV} from 5 ns to 10 ns in TAP AC Switching Characteristics table. Updated the Ordering Information table. |
| *F | 776456 | See ECN | VKN | Added Part numbers CY7C1381F and CY7C1383F and its related information Added footnote# 3 regarding Chip Enable Updated Ordering Information table |