



# SILICON RFIC LOW CURRENT AMPLIFIER FOR MOBILE COMMUNICATIONS

## UPC8178TB

### FEATURES

- **LOW CURRENT CONSUMPTION**  
I<sub>CC</sub> = 1.9 mA TYP @ V<sub>CC</sub> = 3.0 V
- **SUPPLY VOLTAGE:**  
V<sub>CC</sub> = 2.4 to 3.3 V
- **EXCELLENT ISOLATION:**  
ISOL = 39 dB TYP @ f = 1.0 GHz  
ISOL = 40 dB TYP @ f = 1.9 GHz  
ISOL = 38 dB TYP @ f = 2.4 GHz
- **POWER GAIN:**  
GP = 11.0 dB TYP @ f = 1.0 GHz  
GP = 11.5 dB TYP @ f = 1.9 GHz  
GP = 11.5 dB TYP @ f = 2.4 GHz
- **OPERATING FREQUENCY:**  
0.1 to 2.4 GHz (Output port LC matching)
- **1 dB GAIN COMPRESSION OUTPUT POWER:**  
PO(1 dB) = -4.0 dBm TYP @ f = 1.0 GHz  
PO(1 dB) = -7.0 dBm TYP @ f = 1.9 GHz  
PO(1 dB) = -7.5 dBm TYP @ f = 2.4 GHz
- **HIGH-DENSITY SURFACE MOUNTING:**  
6-pin super minimold package (2.0 x 1.25 x 0.9 mm)
- **LOW WEIGHT:**  
7 mg (Standard Value)

POWER GAIN vs. FREQUENCY

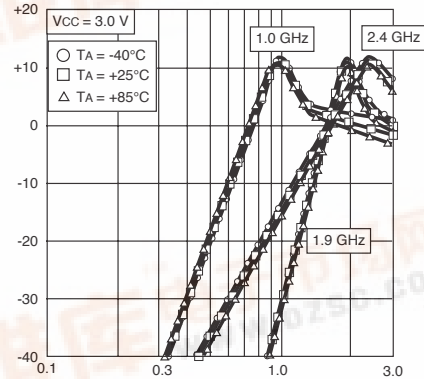

### DESCRIPTION

The UPC8178TB is a silicon monolithic integrated circuit designed as an amplifier for mobile communications. This IC can realize low current consumption with an external chip inductor which cannot be realized on an internal 50 Ω wideband matched IC. This low current amplifier operates on 3.0 V. This device is manufactured using NEC's 30 GHz f<sub>max</sub> UHS0 (Ultra High Speed Process) silicon bipolar process which uses direct silicon nitride passivation film and gold electrodes. These materials can protect the chip surface from pollution and prevent corrosion/migration. Thus, this IC has excellent performance, uniformity and reliability.

NEC's stringent quality assurance and test procedures ensure the highest reliability and performance.

### APPLICATIONS

- Buffer Amplifiers on 0.1 to 2.4 GHz mobile communications system

### ELECTRICAL CHARACTERISTICS

(T<sub>A</sub> = 25°C, V<sub>CC</sub> = V<sub>OUT</sub> = 3.0 V, Z<sub>S</sub> = Z<sub>L</sub> = 50 Ω, at LC matched frequency unless otherwise specified)

PART NUMBER PACKAGE OUTLINE			UPC8178TB S06			
SYMBOLS	PARAMETERS AND CONDITIONS <sup>1</sup>		UNITS	MIN	TYP	MAX
I <sub>CC</sub>	Circuit Current (no signal)		mA	1.4	1.9	2.4
GP	Power Gain	f = 1.0 GHz	dB	9.0	11.0	13.0
		f = 1.9 GHz	dB	9.0	11.5	13.5
		f = 2.4 GHz	dB	9.0	11.5	13.5
ISOL	Isolation	f = 1.0 GHz	dB	34	39	—
		f = 1.9 GHz	dB	35	40	—
		f = 2.4 GHz	dB	33	38	—
PO(1dB)	1 dB Gain Compression Output Power	f = 1.0 GHz	dBm	-8.0	-4.0	—
		f = 1.9 GHz	dBm	-11.0	-7.0	—
		f = 2.4 GHz	dBm	-11.5	-7.5	—
NF	Noise Figure	f = 1.0 GHz	dB	—	5.5	7.0
		f = 1.9 GHz	dB	—	5.5	7.0
		f = 2.4 GHz	dB	—	5.5	7.0
RLin	Input Return Loss	f = 1.0 GHz	dB	4	7	—
		f = 1.9 GHz	dB	5	8	—
		f = 2.4 GHz	dB	6.5	9.5	—



# UPC8178TB

## ABSOLUTE MAXIMUM RATINGS<sup>1</sup>

(T<sub>A</sub> = +25°C unless otherwise specified)

SYMBOLS	PARAMETERS	UNITS	RATINGS
V <sub>CC</sub>	Supply Voltage <sup>2</sup>	V	3.6
I <sub>CC</sub>	Circuit Current	mA	15
P <sub>D</sub>	Power Dissipation <sup>3</sup>	mW	270
T <sub>A</sub>	Operating Ambient Temperature	°C	-40 to +85
T <sub>STG</sub>	Storage Temperature	°C	-55 to +150
P <sub>IN</sub>	Input Power	dBm	+5

Notes:

1. Operation in excess of any one of these conditions may result in permanent damage.
2. Pins 4 and 6.
3. Mounted on a double-sided copper clad 50x50x1.6 mm epoxy glass PWB, T<sub>A</sub> = +85°C.

## RECOMMENDED OPERATING CONDITIONS

SYMBOLS	PARAMETERS	UNITS	MIN	TYP	MAX
V <sub>CC</sub>	Supply Voltage <sup>1</sup>	V	2.4	3.0	3.3
T <sub>A</sub>	Operating Ambient Temperature	°C	-40	+25	+85

Note:

1. Same voltage applied to pins 4 and 6.

## SERIES PRODUCTS<sup>1</sup> (T<sub>A</sub> = +25°C, V<sub>CC</sub> = V<sub>out</sub> = 3.0 V, Z<sub>S</sub> = Z<sub>L</sub> = 50 Ω)

Parameter Part No.	I <sub>CC</sub> (mA)	1.0 GHz output port matching frequency			1.66 GHz output port matching frequency			1.9 GHz output port matching frequency			2.4 GHz output port matching frequency			Marking
		GP (dB)	ISOL (dB)	Po(1 dB) (dBm)	GP (dB)	ISOL (dB)	Po(1 dB) (dBm)	GP (dB)	ISOL (dB)	Po(1 dB) (dBm)	GP (dB)	ISOL (dB)	Po(1 dB) (dBm)	
UPC8178TB	1.9	11	39	-4.0	-	-	-	11.5	40	-7.0	11.5	38	-7.5	C3B
UPC8179TB	4.0	13.5	44	+3.0	-	-	-	15.5	42	+1.5	15.5	41	+1.0	C3C
UPC8128TB	2.8	12.5	39	-4.0	13	39	-4.0	13	37	-4.0	-	-	-	C2P
UPC8151TB	4.2	12.5	38	+2.5	15	36	+1.5	15	34	+0.5	-	-	-	C2U
UPC8152TB	5.6	23	40	-4.5	19.5	38	-8.5	17.5	35	-8.5	-	-	-	C2V

Note:

1. Typical performance.

## PIN FUNCTIONS (Pin Voltage is measured at V<sub>CC</sub> = 3.0 V)

Pin No.	Pin Name	Applied Voltage (V)	Pin Voltage (V)	Function and Applications	Internal Equivalent Circuit
1	Input	-	0.91	Signal input pin. An internal matching circuit, configured with resistors, enables a 50 Ω connection over a wide band. This pin must be coupled to the signal source with the capacitor for DC out.	
2 3 5	GND	0	-	Ground pin. This pin should be connected to the system ground with minimum inductance. Ground pattern on the board should be formed as wide as possible. All the ground pins must be connected together with a wide ground pattern to decrease impedance difference.	
4	Output	Voltage same as V <sub>CC</sub> through external inductor	-	Signal output pin. This pin is designed as the collector output. Due to the high impedance output, this pin should be externally equipped with LC matching circuit to next stage. For L, a size 1005 chip inductor can be used.	
6	V <sub>CC</sub>	2.4 to 3.3	-	Power supply pin. This pin should be externally equipped with a bypass capacitor to minimize its impedance.	

**TEST CIRCUIT 1** (f = 1.0 GHz)

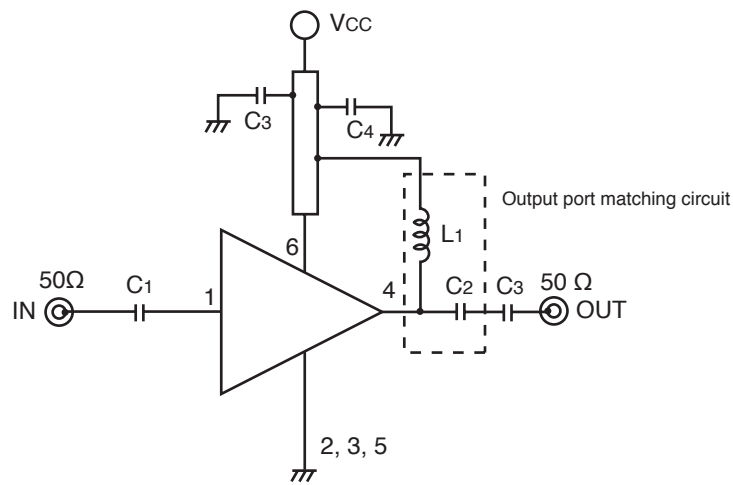

**EXAMPLE OF TEST CIRCUIT 1 ASSEMBLED ON EVALUATION BOARD**

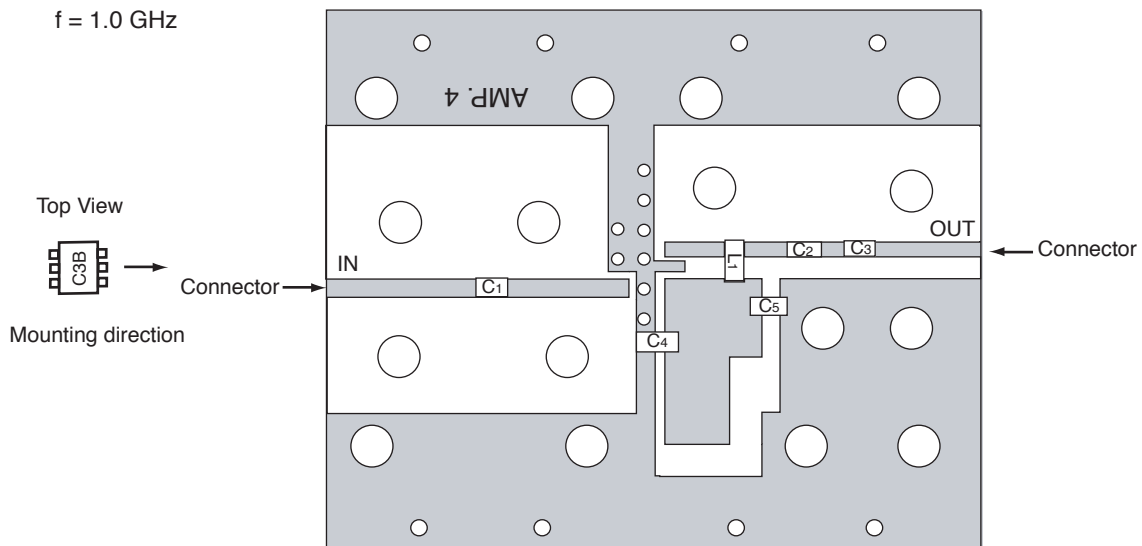

**COMPONENT LIST**

	1.0 GHz Output Port Matching
C1, C3, C5	1000 pF
C2	0.75 pF
C4	10 pF
L1	12 nH

# UPC8178TB

## TEST CIRCUIT 2 (f = 1.9 GHz)

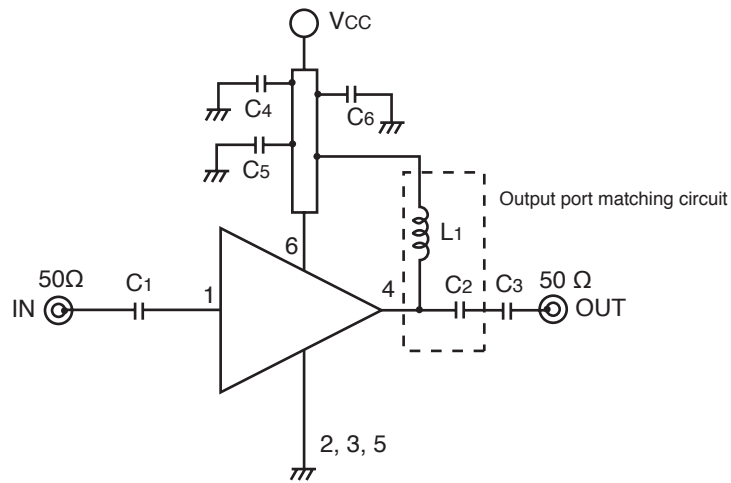

## EXAMPLE OF TEST CIRCUIT 2 ASSEMBLED ON EVALUATION BOARD

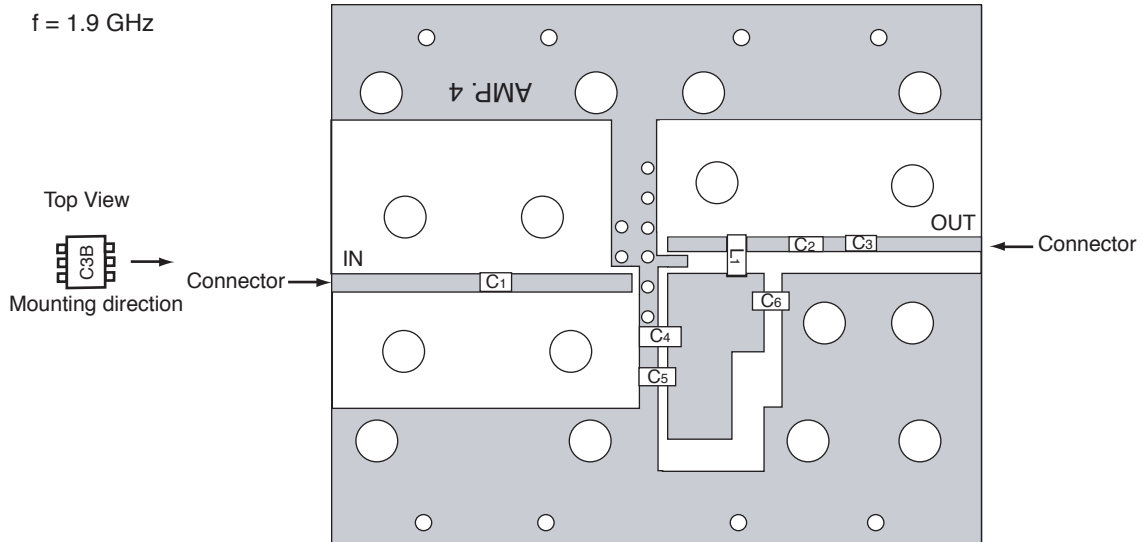

### COMPONENT LIST

	1.9 GHz Output Port Matching
C1, C3, C5, C6	1000 pF
C2	0.5 pF
C4	10 pF
L1	3.9 nH

**TEST CIRCUIT 3** (f = 2.4 GHz)

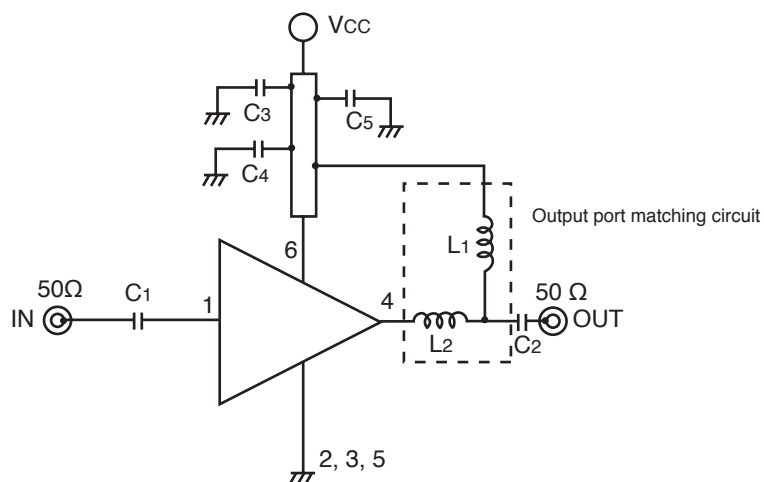

**EXAMPLE OF TEST CIRCUIT 3 ASSEMBLED ON EVALUATION BOARD**

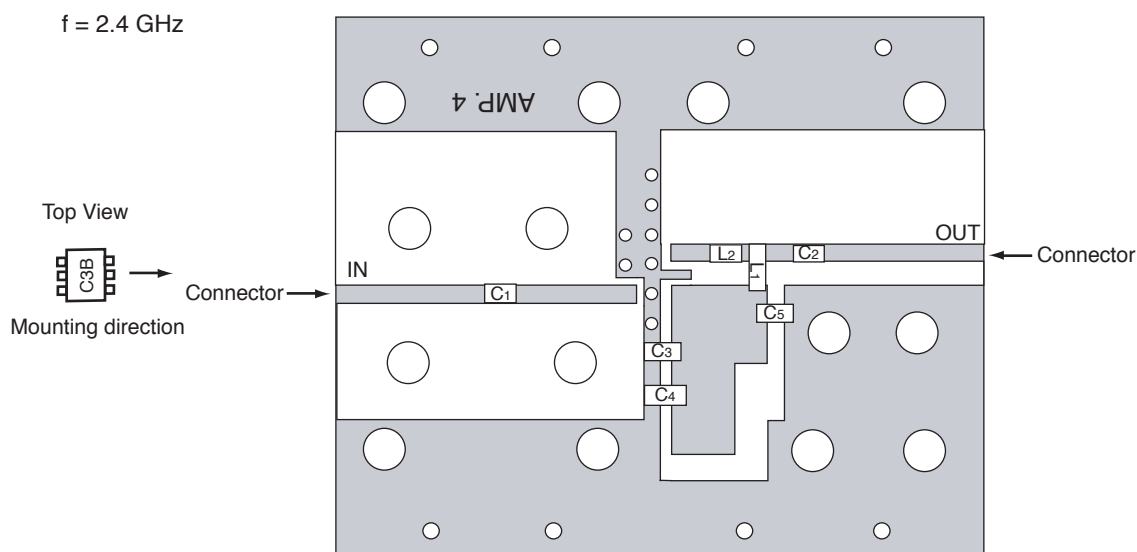

**COMPONENT LIST**

	2.4 GHz Output Port Matching
C1, C3, C4, C5	1000 pF
C3	10 pF
L1	1.8 nH
L2	2.7 nH

NOTES:

1. 42 x 35 x 0.4 mm double sided copper clad polyimide board.
2. Solder plated on pattern.
3. Back side: GND pattern.
4. ○ Through holes.

# UPC8178TB

## OUTLINE DIMENSIONS (Units in mm)

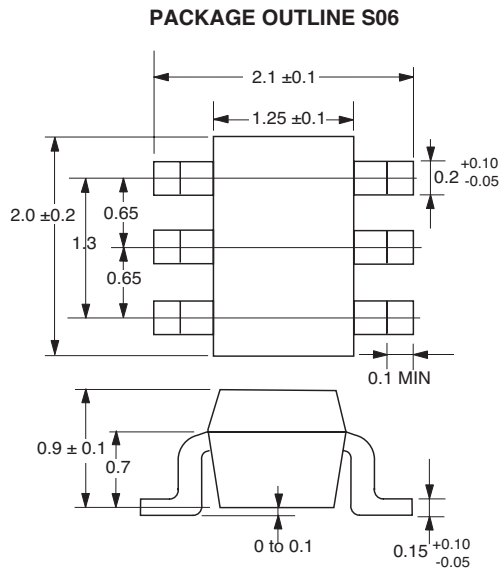

Note:  
All dimensions are typical unless otherwise specified.

## PIN CONNECTIONS

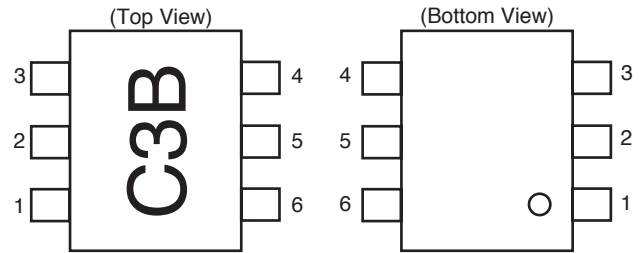

PIN NO.	PIN NAME
1	Input
2	GND
3	GND
4	Output
5	GND
6	Vcc

## SYSTEM APPLICATION EXAMPLE

### Location examples in digital cellular

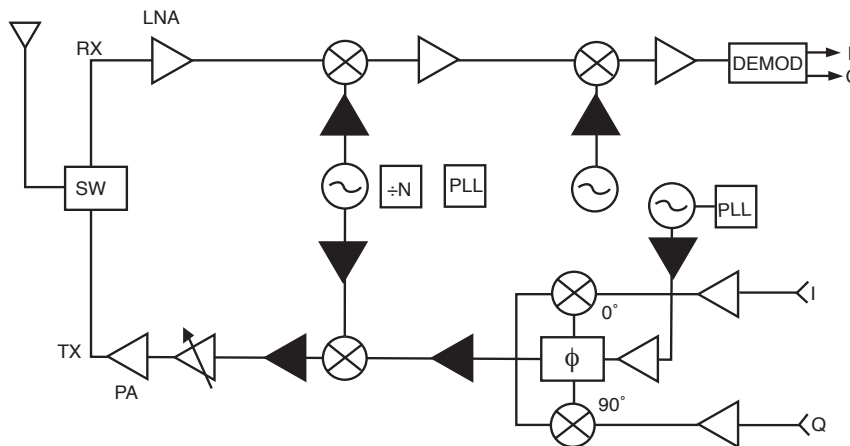

## ORDERING INFORMATION

Part Number	Quantity
UPC8178TB-E3-A	3 K pcs/reel

### Life Support Applications

These NEC products are not intended for use in life support devices, appliances, or systems where the malfunction of these products can reasonably be expected to result in personal injury. The customers of CEL using or selling these products for use in such applications do so at their own risk and agree to fully indemnify CEL for all damages resulting from such improper use or sale.

Note: Embossed tape, 8 mm wide. Pins 1, 2 and 3 face the tape perforation side.

EXCLUSIVE NORTH AMERICAN AGENT FOR **NEC** RF, MICROWAVE & OPTOELECTRONIC SEMICONDUCTORS

**CEL CALIFORNIA EASTERN LABORATORIES** • Headquarters • 4590 Patrick Henry Drive • Santa Clara, CA 95054-1817 • (408) 988-3500 • Telex 34-6393 • FAX (408) 988-0279  
24-Hour Fax-On-Demand: 800-390-3232 (U.S. and Canada only) • Internet: <http://WWW.CEL.COM>

DATA SUBJECT TO CHANGE WITHOUT NOTICE

06/20/2001

Subject: Compliance with EU Directives

CEL certifies, to its knowledge, that semiconductor and laser products detailed below are compliant with the requirements of European Union (EU) Directive 2002/95/EC Restriction on Use of Hazardous Substances in electrical and electronic equipment (RoHS) and the requirements of EU Directive 2003/11/EC Restriction on Penta and Octa BDE.

CEL Pb-free products have the same base part number with a suffix added. The suffix –A indicates that the device is Pb-free. The –AZ suffix is used to designate devices containing Pb which are exempted from the requirement of RoHS directive (\*). In all cases the devices have Pb-free terminals. All devices with these suffixes meet the requirements of the RoHS directive.

This status is based on CEL’s understanding of the EU Directives and knowledge of the materials that go into its products as of the date of disclosure of this information.

Restricted Substance per RoHS	Concentration Limit per RoHS (values are not yet fixed)	Concentration contained in CEL devices	
		-A	-AZ
Lead (Pb)	< 1000 PPM	Not Detected	(*)
Mercury	< 1000 PPM	Not Detected	
Cadmium	< 100 PPM	Not Detected	
Hexavalent Chromium	< 1000 PPM	Not Detected	
PBB	< 1000 PPM	Not Detected	
PBDE	< 1000 PPM	Not Detected	

If you should have any additional questions regarding our devices and compliance to environmental standards, please do not hesitate to contact your local representative.

Important Information and Disclaimer: Information provided by CEL on its website or in other communications concerning the substance content of its products represents knowledge and belief as of the date that it is provided. CEL bases its knowledge and belief on information provided by third parties and makes no representation or warranty as to the accuracy of such information. Efforts are underway to better integrate information from third parties. CEL has taken and continues to take reasonable steps to provide representative and accurate information but may not have conducted destructive testing or chemical analysis on incoming materials and chemicals. CEL and CEL suppliers consider certain information to be proprietary, and thus CAS numbers and other limited information may not be available for release.

In no event shall CEL’s liability arising out of such information exceed the total purchase price of the CEL part(s) at issue sold by CEL to customer on an annual basis.

See CEL Terms and Conditions for additional clarification of warranties and liability.