

## Quad High Speed $\pm 65V$ 750mA Ultrasound Pulser

### Features

- ▶ HVCMOS technology for high performance
- ▶ High density integration ultrasound transmitter
- ▶ 0 to  $\pm 65V$  output voltage
- ▶  $\pm 750mA$  source and sink current in Pulse mode
- ▶  $\pm 110mA$  source and sink current in CW mode
- ▶ Up to 20MHz operating frequency
- ▶ Matched delay times
- ▶ 1.2V to 5.0V CMOS logic interface
- ▶ Built-in output drain bleed resistors

### Application

- ▶ Portable medical ultrasound imaging
- ▶ Piezoelectric transducer drivers
- ▶ NDT ultrasound transmission
- ▶ Pulse waveform generator

### General Description

The Supertex HV738 is a four-channel, monolithic, high voltage, high speed pulse generator. It is designed for portable medical ultrasound applications. This high voltage and high speed integrated circuit can also be used for piezoelectric, capacitive or MEMS sensing in ultrasonic nondestructive detection and sonar ranger applications.

The HV738 consists of a controller logic interface circuit, level translators, MOSFET gate drivers and high current power P-channel and N-channel MOSFETs as the output stage for each channel.

The output stages of each channel are designed to provide peak output currents over  $\pm 1.1A$  for pulsing, when in mode 4, with up to  $\pm 65$  volt swings. When in mode 1, all the output stages drop the peak current to  $\pm 140mA$  for low-voltage CW mode operation to decrease the power consumption of the IC. The P and N type of power FETs gate drivers are supplied by two floating 8.0VDC power supplies referenced to  $V_{PP}$  and  $V_{NN}$ . This direct coupling topology of the gate drivers not only eliminates two high voltage capacitors per channel, but also makes the PCB layout easier.

### Typical Application Circuit

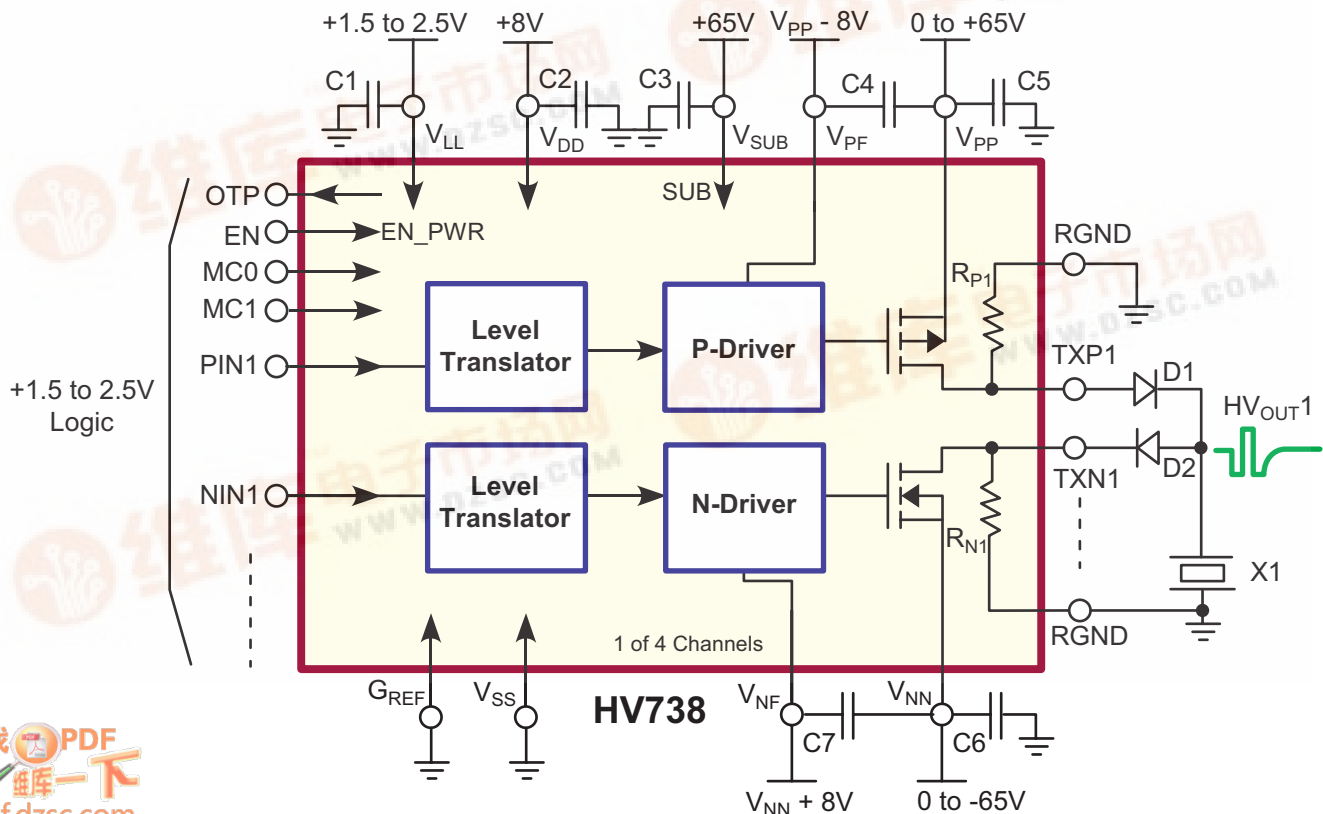

## Ordering Information

Device	Package Options
	48-Lead QFN 7x7mm body, 1.0mm height (max), 0.5mm pitch
HV738	HV738K6-G

-G indicates package is RoHS compliant ("Green")



## Absolute Maximum Ratings

Parameter	Value
$V_{SS}$ , Power supply reference	0V
$V_{LL}$ , Positive logic supply	-0.5V to +7V
$V_{DD}$ , Positive logic and level translator supply	-0.5V to +14V
$(V_{PP} - V_{PF})$ Positive floating gate drive supply	-0.5V to +14V
$(V_{NF} - V_{NN})$ Negative gate floating drive supply	-0.5V to +14V
$(V_{PP} - V_{NN})$ Differential high voltage supply	+140V
$V_{PP}$ , High voltage positive supply	-0.5V to +70V
$V_{NN}$ , High voltage negative supply	+0.5V to -70V
OTP, Over Temperature Protection output	-0.5V to +7V
All logic input $PIN_x$ , $NIN_x$ and EN voltages	-0.5V to +7V
$(V_{SUB} - V_{SS})$ Substrate to $V_{SS}$ voltage difference	+140V
$(V_{PP} - TXP_x)$ $V_{PP}$ to $TXP_x$ voltage difference	+140V
$(V_{SUB} - TXP_x)$ Substrate to $TXP_x$ voltage difference	+140V
$(TXN_x - V_{NN})$ $TXN_x$ to $V_{NN}$ voltage difference	+140V
Operating temperature	-40°C to 125°C
Storage temperature	-65°C to 150°C
Thermal resistance, $\theta_{JA}$	29°C/W
Thermal resistance, $\theta_{JC}$ (Junction to thermal pad)	0.5°C/W

Absolute Maximum Ratings are those values beyond which damage to the device may occur. Functional operation under these conditions is not implied. Continuous operation of the device at the absolute rating level may affect device reliability. All voltages are referenced to device ground.

## Pin Configuration

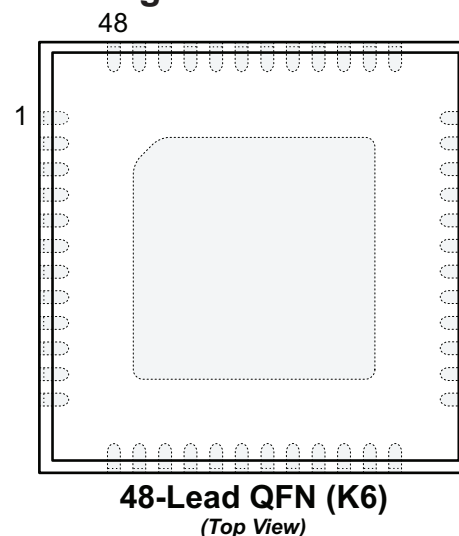

## Package Marking

• HV738K6  
 LLLLLLLL  
 YYWW  
 AAA CCC

L = Lot Number  
 YY = Year Sealed  
 WW = Week Sealed  
 A = Assembler ID  
 C = Country of Origin  
 — = "Green" Packaging

### 48-Lead QFN

## Power-Up Sequence

1	$V_{SUB}$
2	$V_{LL}$ with logic signal low
3	$V_{DD}$
4	$(V_{PP} - V_{PF})$ and $(V_{NF} - V_{NN})$
5	$V_{PP}$ and $V_{NN}$
6	Logic control signals

## Power-Down Sequence

1	All logic signals go to low
2	$V_{PP}$ and $V_{NN}$
3	$(V_{PP} - V_{PF})$ and $(V_{NF} - V_{NN})$
4	$V_{DD}$
5	$V_{LL}$
6	$V_{SUB}$

## Operating Supply Voltages and Current (4 Channel Active)

(Operating conditions, unless otherwise specified,  $V_{SS} = 0V$ ,  $V_{LL} = +2.5V$ ,  $V_{DD} = +8V$ ,  $V_{PP}-V_{PF} = +8V$ ,  $V_{NN}-V_{NF} = -8V$ ,  $V_{PP} = +65V$ ,  $V_{NN} = -65V$ ,  $T_A = 25^\circ C$ )

Symbol	Parameter	Min	Typ	Max	Units	Conditions
$V_{LL}$	Logic voltage reference	1.2	2.5	5.0	V	---
$V_{DD}$	Internal voltage supply	7.5	8.0	10	V	---
$V_{PF}$	Positive gate driver supply	$(V_{PP}-10)$	$(V_{PP}-8.0)$	$(V_{PP}-7.5)$	V	Floating driver voltage supplies.
$V_{NF}$	Negative gate drive supply	$(V_{NN}+7.5)$	$(V_{NN}+8.0)$	$(V_{NN}+10)$	V	
$V_{SUB}$	IC substrate voltage	$V_{DD}$	$V_{PP}$	+65	V	Must be the most positive potential of the IC.
$V_{PP}$	Positive HV supply	0	-	+65	V	---
$V_{NN}$	Negative HV supply	-65	-	0	V	---
$SR_{MAX}$	Slew rate limit of $V_{PP}$ , $V_{NN}$	-	-	25	V/ $\mu$ s	Built-in slew rate detection protection.
$I_{LL}$	$V_{LL}$ Current EN = Low	-	35	120	$\mu$ A	---
$I_{DDQ}$	$V_{DD}$ Current EN = Low	-	10	-	$\mu$ A	---
$I_{DDEN}$	$V_{DD}$ Current EN = High	-	0.75	2.0	mA	f = 0MHz
$I_{DDEN}$	$V_{DD}$ Current MODE = 4	-	2.0	-	mA	f = 5.0MHz, continuous, no loads
$I_{DDENCW}$	$V_{DD}$ Current MODE = 1	-	5.0	-	mA	
$I_{PPQ}$	$V_{PP}$ Current EN = Low	-	10	20	$\mu$ A	f = 0MHz
$I_{PPEN}$	$V_{PP}$ Current MODE = 4	-	200	-	mA	f = 5.0MHz, continuous, no loads
$I_{PPENCW}$	$V_{PP}$ Current MODE = 1	-	140	-	mA	
$I_{NNQ}$	$V_{NN}$ Current EN = Low	-	10	20	$\mu$ A	f = 0MHz
$I_{NNEN}$	$V_{NN}$ Current MODE = 4	-	170	-	mA	f = 5.0MHz, continuous, no loads
$I_{NNENCW}$	$V_{NN}$ Current MODE = 1	-	140	-	mA	
$I_{PFQ}$	$V_{PF}$ Current EN = Low	-	8.0	20	$\mu$ A	f = 0MHz
$I_{PFEN}$	$V_{PF}$ Current MODE = 4	-	30	-	mA	f = 5.0MHz, continuous, no loads
$I_{PFENCW}$	$V_{PF}$ Current MODE = 1	-	10	-	mA	
$I_{NFQ}$	$V_{NF}$ Current EN = Low	-	10	20	$\mu$ A	f = 0MHz
$I_{NFEN}$	$V_{NF}$ Current MODE = 4	-	12	-	mA	f = 5.0MHz, continuous, no loads
$I_{NFENCW}$	$V_{NF}$ Current MODE = 1	-	5.0	-	mA	

## Under Voltage and Over Temperature Protection

Symbol	Parameter	Min	Typ	Max	Units	Conditions
$V_{PULL\_UP}$	Open drain pull-up voltage	-	-	5.0	V	---
$V_{UVDD}$	$V_{DD}$ threshold	3.5	6.0	7.0	V	---
$V_{UVLL}$	$V_{LL}$ threshold	0.8	0.9	1.0	V	---
$V_{UVVF}$	$V_{PF}$ , $V_{NF}$ threshold	2.7	4.75	5.4	V	---
$V_{OL\_OTP}$	OTP flag output low voltage	-	-	1.0	V	$V_{LL} = 2.5V$ , OTP = Active, $I_{PULL\_UP} = 1.0mA$ .
$I_{OTP}$	Max. open drain output current	-	1.0	-	mA	---
$T_{OTP}$	Over-temperature threshold	95	110	125	$^\circ C$	If over-temperature occurred, OTP low and all TX outputs will be HiZ.
$T_{HYS}$	OTP output reset hysteresis	-	7.0	-		

## Electrical Characteristics

(Operating conditions, unless otherwise specified,  $V_{SS} = 0V$ ,  $V_{LL} = +2.5V$ ,  $V_{DD} = +8V$ ,  $V_{PP} - V_{PF} = +8V$ ,  $V_{NN} - V_{NF} = -8V$ ,  $V_{PP} = +65V$ ,  $V_{NN} = -65V$ ,  $T_A = 25^\circ C$ )

### Output P-Channel MOSFET, TXP (Mode 4)

Symbol	Parameter	Min	Typ	Max	Units	Conditions
$I_{OUT}$	Output saturation current	0.75	1.2	-	A	---
$R_{ON}$	Channel resistance	-	13	-	$\Omega$	$I_{SD} = 100mA$
$C_{OSS}$	Output capacitance	-	50	-	pF	$V_{DS} = 25V$ , $f = 1.0MHz$

### Output N-Channel MOSFET, TXN (Mode 4)

Symbol	Parameter	Min	Typ	Max	Units	Conditions
$I_{OUT}$	Output saturation current	0.75	1.1	-	A	---
$R_{ON}$	Channel resistance	-	12.5	-	$\Omega$	$I_{SD} = 100mA$
$C_{OSS}$	Output capacitance	-	20	-	pF	$V_{DS} = 25V$ , $f = 1.0MHz$

### MOSFET Drain Bleed Resistor

Symbol	Parameter	Min	Typ	Max	Units	Conditions
$R_{P/N1-4}$	Output bleed resistance	10	15	20	k $\Omega$	---
$P_{RO}$	Bleed resistors power limit	-	-	40	mW	---

### Logic Inputs

Symbol	Parameter	Min	Typ	Max	Units	Conditions
$V_{IH}$	Input logic high voltage	$(V_{LL} - 0.4)$	-	$V_{LL}$	V	---
$V_{IL}$	Input logic low voltage	0	-	0.4	V	---
$I_{IH}$	Input logic high current	-	-	10	$\mu A$	---
$I_{IL}$	Input logic low current	-10	-	-	$\mu A$	---
$C_{IN}$	Input logic capacitance	-	-	5.0	pF	---

### AC Electrical Characteristics

(Operating conditions, unless otherwise specified,  $V_{SS} = 0V$ ,  $V_{LL} = +2.5V$ ,  $V_{DD} = +8V$ ,  $V_{PP} - V_{PF} = +8V$ ,  $V_{NN} - V_{NF} = -8V$ ,  $V_{PP} = +65V$ ,  $V_{NN} = -65V$ ,  $T_A = 25^\circ C$ )

Symbol	Parameter	Min	Typ	Max	Units	Conditions
$t_r$	Output rise time	-	35	-	ns	330pF//2.5k $\Omega$ load
$t_f$	Output fall time	-	43	-	ns	
$f_{OUT}$	Output frequency range	-	-	20	MHz	100 $\Omega$ resistor load
HD2	Second harmonic distortion	-	-35	-	dB	
$t_{EN}$	Enable time	-	180	500	$\mu s$	
$t_{DIS}$	Disable time	-	2.8	10	$\mu s$	
$t_{dr}$	Delay time on inputs rise	-	22	-	ns	
$t_{df}$	Delay time on inputs fall	-	22	-	ns	
$t_{dm}$	Delay on mode change	-	2.5	10	$\mu s$	
$\Delta t_{DELAY}$	$ t_{dr} - t_{df} $ Delay time matching	-	-	$\pm 3.0$	ns	P to N, channel to channel
$t_j$	Delay jitter on rise or fall	-	13	-	ps	$V_{PP}/V_{NN} = \pm 25V$ , input $t_r$ , 50% to HV $_{OUT}$ $t_r$ or $t_f$ , 50%, with 330pF//2.5k $\Omega$ load

## Switching Time Diagram

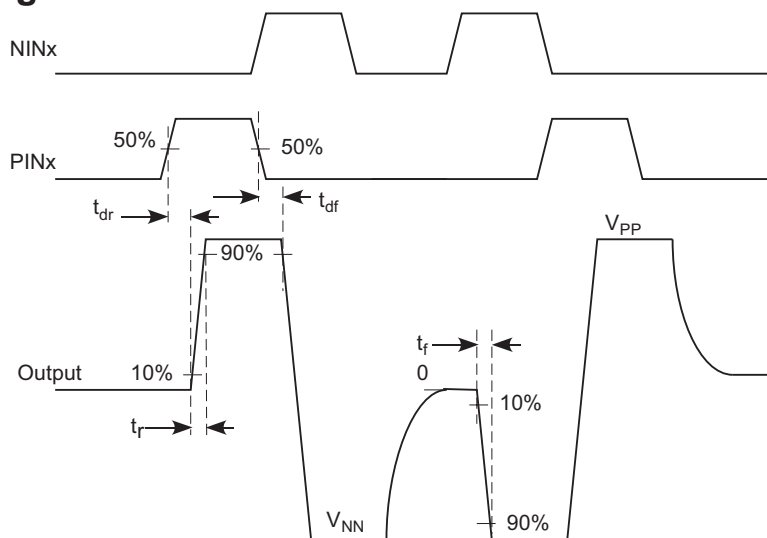

## Truth Table (All Modes)

Logic Inputs			Output	
EN	PIN <sub>x</sub>	NIN <sub>x</sub>	TXP <sub>x</sub>	TXN <sub>x</sub>
1	0	0	OFF	OFF
1	1	0	ON	OFF
1	0	1	OFF	ON
1	1	1	ON*	ON*
0	X	X	OFF	OFF

\*Note: Not allowed, may damage IC

## Drive Mode Control Table

Mode	MC1	MC0	I <sub>SC</sub> (A)	R <sub>ONP</sub> (Ω)	R <sub>ONR</sub> (Ω)
1	0	0	0.28	56.0	54.0
2	0	1	0.38	41.0	39.5
3	1	0	0.65	24.0	23.0
4	1	1	1.20	13.0	12.5

\*Note:

1.  $V_{PF}/V_{NN} = +/-65V$ ,  $V_{DD} = (V_{PP} - V_{PF}) = (V_{NF} - V_{NN}) = +8.0V$

2. I<sub>SC</sub> is current into 1.0Ω to GND

3. R<sub>ON</sub> calculated from V<sub>OUT</sub> into 100Ω load

## Pin Description

Pin #	Name	Function
1, 12	V <sub>DD</sub>	Positive internal voltage supply (+8.0V).
2, 11	V <sub>SS</sub>	Power supply return (0V).
48	V <sub>LL</sub>	Logic Hi voltage reference input (+2.5V).
47	G <sub>REF</sub>	Logic Low reference, logic ground (0V).
26, 35	RGND	Bleed resistors common return ground. (Both pins must be used)
18, 19, 20, 41, 42, 43	V <sub>PP</sub>	Positive high voltage power supply (+65V).
21, 22, 23, 38, 39, 40	V <sub>NN</sub>	Negative high voltage power supply (-65V).
17, 44	V <sub>PF</sub>	P-FET drive floating power supply, (V <sub>PP</sub> - V <sub>PF</sub> ) = +8.0V.
24, 37	V <sub>NF</sub>	N-FET drive floating power supply, (V <sub>NF</sub> - V <sub>NN</sub> ) = +8.0V.
34	TXP1	Output P-FET drain (open drain output) for channel 1.
33	TXN1	Output N-FET drain (open drain output) for channel 1.
32	TXP2	Output P-FET drain (open drain output) for channel 2.
31	TXN2	Output N-FET drain (open drain output) for channel 2.
30	TXP3	Output P-FET drain (open drain output) for channel 3.
29	TXN3	Output N-FET drain (open drain output) for channel 3.
28	TXP4	Output P-FET drain (open drain output) for channel 4.
27	TXN4	Output N-FET drain (open drain output) for channel 4.
3	PIN1	Input logic control of high voltage output P-FET of channel 1, Hi=on, Low=off.
4	NIN1	Input logic control of high voltage output N-FET of channel 1, Hi=on, Low=off.
5	PIN2	Input logic control of high voltage output P-FET of channel 2, Hi=on, Low=off.
6	NIN2	Input logic control of high voltage output N-FET of channel 2, Hi=on, Low=off.
7	PIN3	Input logic control of high voltage output P-FET of channel 3, Hi=on, Low=off.
8	NIN3	Input logic control of high voltage output N-FET of channel 3, Hi=on, Low=off.
9	PIN4	Input logic control of high voltage output P-FET of channel 4, Hi=on, Low=off.
10	NIN4	Input logic control of high voltage output N-FET of channel 4, Hi=on, Low=off.
46	EN	Chip power enable Hi=on, Low=off.
15	MC0	Output current mode control pins, see Drive Mode Control Table.
14	MC1	
13	OTP	Over temperature protection output, open N-FET drain, active low if IC temperature >110°C.
16, 25, 36, 45	Thermal Pad (V <sub>SUB</sub> )	Substrate of the IC, Substrate bottom is internally connected to the central thermal pad on the bottom of package. It must be connected to V <sub>SUB</sub> , the most positive potential of the IC externally.

# 48-Lead QFN Package Outline (K6)

7x7mm body, 1.0mm height (max), 0.50mm pitch

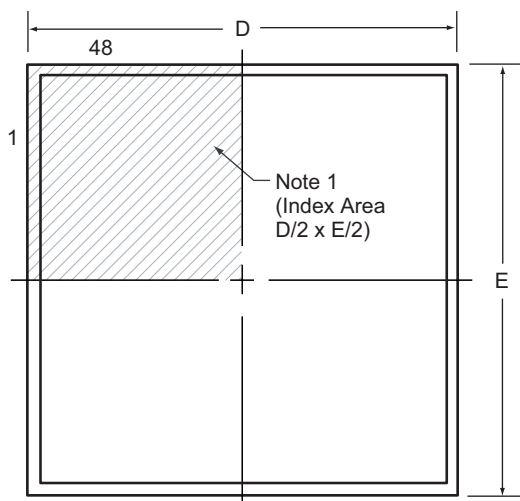

**Top View**

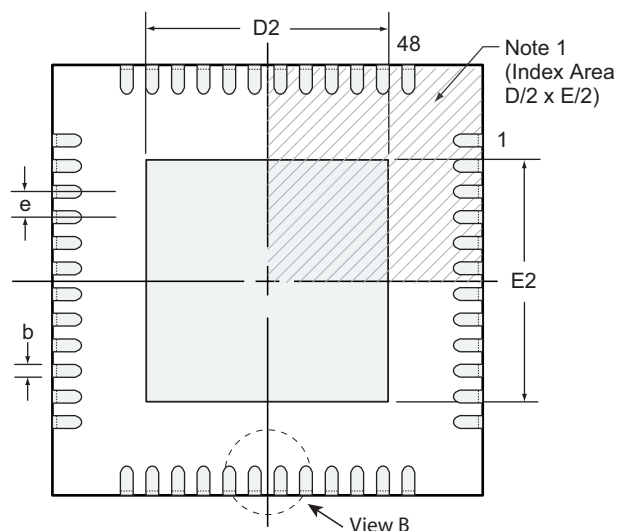

**Bottom View**

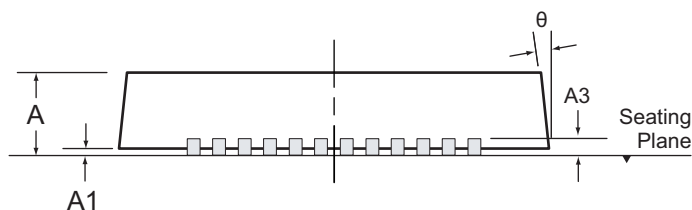

**Side View**

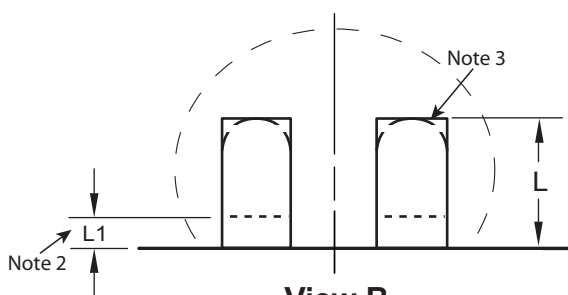

**View B**

**Notes:**

1. Details of Pin 1 identifier are optional, but must be located within the indicated area. The Pin 1 identifier may be either a mold, or an embedded metal or marked feature.
2. Depending on the method of manufacturing, a maximum of 0.15mm pullback (L1) may be present.
3. The inner tip of the lead may be either rounded or square.

Symbol	A	A1	A3	b	D	D2	E	E2	e	L	L1	θ	
Dimension (mm)	MIN	0.80	0.00	0.20 REF	0.18	6.85	2.25	6.85	2.25	0.50 BSC	0.30	0.00	0°
	NOM	0.90	0.02		0.25	7.00	4.70	7.00	4.70		0.40	-	-
	MAX	1.00	0.05		0.30	7.15	5.25	7.15	5.25		0.50	0.15	14°

JEDEC Registration MO-220, Variation VKKD-2, Issue K, June 2006.

Drawings are not to scale.

(The package drawing(s) in this data sheet may not reflect the most current specifications. For the latest package outline information go to <http://www.supertex.com/packaging.html>.)

**Supertex inc.** does not recommend the use of its products in life support applications, and will not knowingly sell its products for use in such applications, unless it receives an adequate "product liability indemnification insurance agreement". **Supertex** does not assume responsibility for use of devices described and limits its liability to the replacement of the devices determined defective due to workmanship. No responsibility is assumed for possible omissions or inaccuracies. Circuitry and specifications are subject to change without notice. For the latest product specifications, refer to the **Supertex** website: <http://www.supertex.com>.