

## Features

- Low-voltage and Standard-voltage Operation
  - 2.7 ( $V_{CC} = 2.7V$  to 5.5V)
  - 1.8 ( $V_{CC} = 1.8V$  to 5.5V)
- User Selectable Internal Organization
  - 16K: 2048 x 8 or 1024 x 16
- Three-wire Serial Interface
- Sequential Read Operation
- Schmitt Trigger, Filtered Inputs for Noise Suppression
- 2 MHz Clock Rate (5V) Compatibility
- Self-timed Write Cycle (10 ms max)
- High Reliability
  - Endurance: 1 Million Write Cycles
  - Data Retention: 100 Years
- Automotive Devices Available
- 8-lead JEDEC PDIP, 8-lead JEDEC SOIC, 8-lead Ultra Thin Mini-MAP (MLP 2x3), and 8-lead TSSOP Packages
- Die Sales: Wafer Form, Waffle Pack and Bumped Wafers

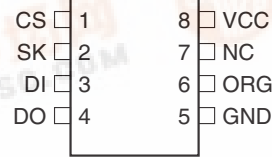
## Description

The AT93C86A provides 16384 bits of serial electrically erasable programmable read only memory (EEPROM), organized as 1024 words of 16 bits each when the ORG pin is connected to  $V_{CC}$  and 2048 words of eight bits each when it is tied to ground. The device is optimized for use in many industrial and commercial applications where low-power and low-voltage operations are essential. The AT93C86A is available in space saving 8-lead PDIP, 8-lead JEDEC SOIC, 8-lead Ultra Thin Mini-MAP (MLP 2x3), and 8-lead TSSOP packages.

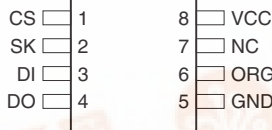
Table 1. Pin Configurations

Pin Name	Function
CS	Chip Select
SK	Serial Data Clock
DI	Serial Data Input
DO	Serial Data Output
GND	Ground
VCC	Power Supply
ORG	Internal Organization
NC	No Connect

8-lead PDIP



8-lead SOIC



8-lead Ultra Thin Mini-MAP (MLP 2x3)



Bottom View

8-lead TSSOP



## Three-wire Serial EEPROM

16K (2048 x 8 or 1024 x 16)

## AT93C86A





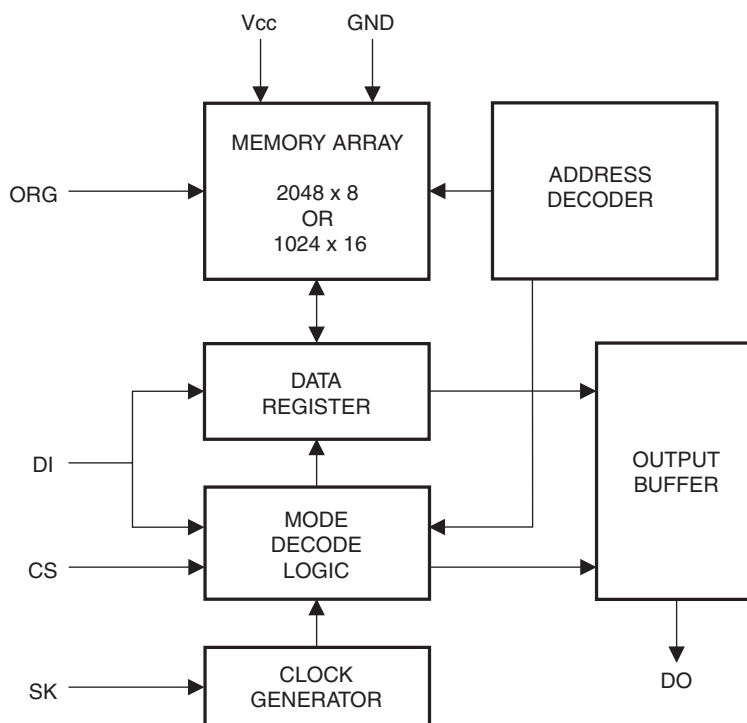
The AT93C86A is enabled through the Chip Select pin (CS), and accessed via a three-wire serial interface consisting of Data Input (DI), Data Output (DO), and Shift Clock (SK). Upon receiving a Read instruction at DI, the address is decoded and the data is clocked out serially on the data output pin DO. The Write cycle is completely self-timed and no separate Erase cycle is required before Write. The Write cycle is only enabled when the part is in the Erase/Write Enable state. When CS is brought “high” following the initiation of a Write cycle, the DO pin outputs the Ready/Busy status of the part. The AT93C86A is available in a 2.7V to 5.5V version.

### Absolute Maximum Ratings\*

Operating Temperature.....	-55°C to +125°C
Storage Temperature .....	-65°C to +150°C
Voltage on any Pin with Respect to Ground.....	-1.0V to +7.0V
Maximum Operating Voltage .....	6.25V
DC Output Current.....	5.0 mA

\*NOTICE: Stresses beyond those listed under “Absolute Maximum Ratings” may cause permanent damage to the device. This is a stress rating only and functional operation of the device at these or any other conditions beyond those indicated in the operational sections of this specification is not implied. Exposure to absolute maximum rating conditions for extended periods may affect device reliability

Figure 1. Block Diagram



Note: When the ORG pin is connected to Vcc, the x 16 organization is selected. When it is connected to ground, the x 8 organization is selected. If the ORG pin is left unconnected and the application does not load the input beyond the capability of the internal 1 Meg ohm pullup, then the x 16 organization is selected.

**Table 2.** Pin Capacitance<sup>(1)</sup>

Applicable over recommended operating range from  $T_A = 25^\circ\text{C}$ ,  $f = 1.0\text{ MHz}$ ,  $V_{CC} = +5.0\text{V}$  (unless otherwise noted)

Symbol	Test Conditions	Max	Units	Conditions
$C_{OUT}$	Output Capacitance (DO)	5	pF	$V_{OUT} = 0\text{V}$
$C_{IN}$	Input Capacitance (CS, SK, DI)	5	pF	$V_{IN} = 0\text{V}$

Note: 1. This parameter is characterized and is not 100% tested.

**Table 3.** DC Characteristics

Applicable over recommended operating range from:  $T_{AI} = -40^\circ\text{C}$  to  $+85^\circ\text{C}$ ,  $V_{CC} = +1.8\text{V}$  to  $+5.5\text{V}$ ,  
 $T_{AE} = -40^\circ\text{C}$  to  $+125^\circ\text{C}$ ,  $V_{CC} = +1.8\text{V}$  to  $+5.5\text{V}$  (unless otherwise noted)

Symbol	Parameter	Test Condition	Min	Typ	Max	Unit
$V_{CC1}$	Supply Voltage		1.8		5.5	V
$V_{CC2}$	Supply Voltage		2.7		5.5	V
$V_{CC3}$	Supply Voltage		4.5		5.5	V
$I_{CC}$	Supply Current	$V_{CC} = 5.0\text{V}$	READ at 1.0 MHz	0.5	2.0	mA
			WRITE at 1.0 MHz	0.5	2.0	mA
$I_{SB1}$	Standby Current	$V_{CC} = 1.8\text{V}$	CS = 0V	0	0.1	$\mu\text{A}$
$I_{SB2}$	Standby Current	$V_{CC} = 2.7\text{V}$	CS = 0V	6.0	10.0	$\mu\text{A}$
$I_{SB3}$	Standby Current	$V_{CC} = 5.0\text{V}$	CS = 0V	17	30	$\mu\text{A}$
$I_{IL}$	Input Leakage	$V_{IN} = 0\text{V}$ to $V_{CC}$		0.1	3.0	$\mu\text{A}$
$I_{OL}$	Output Leakage	$V_{IN} = 0\text{V}$ to $V_{CC}$		0.1	3.0	$\mu\text{A}$
$V_{IL1}^{(1)}$ $V_{IH1}^{(1)}$	Input Low Voltage Input High Voltage	$2.7\text{V} \leq V_{CC} \leq 5.5\text{V}$	--0.6 2.0		0.8 $V_{CC} + 1$	V
$V_{IL2}^{(1)}$ $V_{IH2}^{(1)}$	Input Low Voltage Input High Voltage	$1.8\text{V} \leq V_{CC} \leq 2.7\text{V}$	-0.6 $V_{CC} \times 0.7$		$V_{CC} \times 0.3$ $V_{CC} + 1$	V
$V_{OL1}$ $V_{OH1}$	Output Low Voltage Output High Voltage	$2.7\text{V} \leq V_{CC} \leq 5.5\text{V}$	$I_{OL} = 2.1\text{ mA}$		0.4	V
			$I_{OH} = -0.4\text{ mA}$	2.4		V
$V_{OL2}$ $V_{OH2}$	Output Low Voltage Output High Voltage	$1.8\text{V} \leq V_{CC} \leq 2.7\text{V}$	$I_{OL} = 0.15\text{ mA}$		0.2	V
			$I_{OH} = -100\text{ }\mu\text{A}$	$V_{CC} - 0.2$		V

Note: 1.  $V_{IL}$  min and  $V_{IH}$  max are reference only and are not tested.



**Table 4.** AC Characteristics

Applicable over recommended operating range from  $T_{AI} = -40^{\circ}\text{C}$  to  $+85^{\circ}\text{C}$ ,  $T_{AE} = -40^{\circ}\text{C}$  to  $+125^{\circ}\text{C}$ ,  $V_{CC} = \text{As Specified}$ ,  $CL = 1$  TTL Gate and  $100\text{ pF}$  (unless otherwise noted)

Symbol	Parameter	Test Condition	Min	Typ	Max	Units
$f_{SK}$	SK Clock Frequency	$4.5V \leq V_{CC} \leq 5.5V$ $2.7V \leq V_{CC} \leq 5.5V$ $1.8V \leq V_{CC} \leq 5.5V$	0 0 0		2 1 0.25	MHz
$t_{SKH}$	SK High Time	$2.7V \leq V_{CC} \leq 5.5V$ $1.8V \leq V_{CC} \leq 5.5V$	250 1000			ns
$t_{SKL}$	SK Low Time	$2.7V \leq V_{CC} \leq 5.5V$ $1.8V \leq V_{CC} \leq 5.5V$	250 1000			ns
$t_{CS}$	Minimum CS Low Time	$2.7V \leq V_{CC} \leq 5.5V$ $1.8V \leq V_{CC} \leq 5.5V$	250 1000			ns
$t_{CSS}$	CS Setup Time	Relative to SK $2.7V \leq V_{CC} \leq 5.5V$ $1.8V \leq V_{CC} \leq 5.5V$	50 200			ns
$t_{DIS}$	DI Setup Time	Relative to SK $2.7V \leq V_{CC} \leq 5.5V$ $1.8V \leq V_{CC} \leq 5.5V$	100 400			ns
$t_{CSH}$	CS Hold Time	Relative to SK	0			ns
$t_{DIH}$	DI Hold Time	Relative to SK $2.7V \leq V_{CC} \leq 5.5V$ $1.8V \leq V_{CC} \leq 5.5V$	100 400			ns
$t_{PD1}$	Output Delay to "1"	AC Test $2.7V \leq V_{CC} \leq 5.5V$ $1.8V \leq V_{CC} \leq 5.5V$			250 1000	ns
$t_{PD0}$	Output Delay to "0"	AC Test $2.7V \leq V_{CC} \leq 5.5V$ $1.8V \leq V_{CC} \leq 5.5V$			250 1000	ns
$t_{SV}$	CS to Status Valid	AC Test $2.7V \leq V_{CC} \leq 5.5V$ $1.8V \leq V_{CC} \leq 5.5V$			250 1000	ns
$t_{DF}$	CS to DO in High Impedance	AC Test CS = $V_{IL}$ $2.7V \leq V_{CC} \leq 5.5V$ $1.8V \leq V_{CC} \leq 5.5V$			150 400	ns
$t_{WP}$	Write Cycle Time	$1.8V \leq V_{CC} \leq 5.5V$	0.1	3	10	ms
						ms
Endurance <sup>(1)</sup>	5.0V, 25°C		1M			Write Cycles

Note: 1. This parameter is ensured by characterization.

**Table 5.** Instruction Set for the AT93C86A

Instruction	SB	Op Code	Address		Data		Comments
			x 8	x 16	x 8	x 16	
READ	1	10	$A_{10} - A_0$	$A_9 - A_0$			Reads data stored in memory, at specified address.
EWEN	1	00	11XXXXXXXXXX	11XXXXXXXXXX			Write enable must precede all programming modes.
ERASE	1	11	$A_{10} - A_0$	$A_9 - A_0$			Erases memory location $A_n - A_0$ .
WRITE	1	01	$A_{10} - A_0$	$A_9 - A_0$	$D_7 - D_0$	$D_{15} - D_0$	Writes memory location $A_n - A_0$ .
ERAL	1	00	10XXXXXXXXXX	10XXXXXXXXXX			Erases all memory locations. Valid only at $V_{CC} = 4.5V$ to $5.5V$ .
WRAL	1	00	01XXXXXXXXXX	01XXXXXXXXXX	$D_7 - D_0$	$D_{15} - D_0$	Writes all memory locations. Valid when $V_{CC} = 4.5V$ to $5.5V$ and Disable Register cleared.
EWDS	1	00	00XXXXXXXXXX	00XXXXXXXXXX			Disables all programming instructions.

## Functional Description

The AT93C86A is accessed via a simple and versatile three-wire serial communication interface. Device operation is controlled by seven instructions issued by the host processor. **A valid instruction starts with a rising edge of CS** and consists of a Start Bit (logic “1”) followed by the appropriate Op Code and the desired memory address location.

**READ (READ):** The Read (READ) instruction contains the address code for the memory location to be read. After the instruction and address are decoded, data from the selected memory location is available at the serial output pin DO. Output data changes are synchronized with the rising edges of serial clock SK. It should be noted that a dummy bit (logic “0”) precedes the 8- or 16-bit data output string. The AT93C86A supports sequential read operations. The device will automatically increment the internal address pointer and clock out the next memory location as long as CS is held high. In this case, the dummy bit (logic “0”) will not be clocked out between memory locations, thus allowing for a continuous stream of data to be read.

**ERASE/WRITE (EWEN):** To assure data integrity, the part automatically goes into the Erase/Write Disable (EWDS) state when power is first applied. An Erase/Write Enable (EWEN) instruction must be executed first before any programming instructions can be carried out. Please note that once in the EWEN state, programming remains enabled until an EWDS instruction is executed or  $V_{CC}$  power is removed from the part.

**ERASE (ERASE):** The Erase (ERASE) instruction programs all bits in the specified memory location to the logical “1” state. The self-timed erase cycle starts once the ERASE instruction and address are decoded. The DO pin outputs the Ready/Busy status of the part if CS is brought high after being kept low for a minimum of 250 ns ( $t_{CS}$ ). A logic “1” at pin DO indicates that the selected memory location has been erased, and the part is ready for another instruction.

**WRITE (WRITE):** The Write (WRITE) instruction contains the 8 or 16 bits of data to be written into the specified memory location. The self-timed programming cycle  $t_{VP}$  starts after the last bit of data is received at serial data input pin DI. The DO pin outputs the Ready/Busy status of the part if CS is brought high after being kept low for a minimum of



250 ns ( $t_{CS}$ ). A logic "0" at DO indicates that programming is still in progress. A logic "1" indicates that the memory location at the specified address has been written with the data pattern contained in the instruction and the part is ready for further instructions. *A Ready/Busy status cannot be obtained if the CS is brought high after the end of the self-timed programming cycle  $t_{WP}$ .*

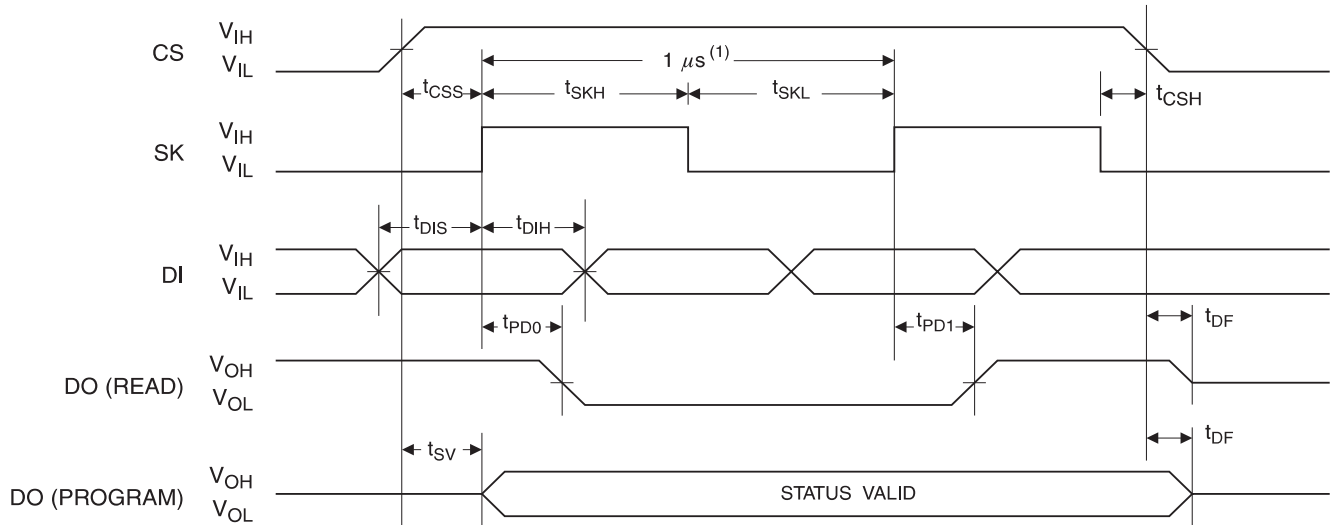
**ERASE ALL (ERAL):** The Erase All (ERAL) instruction programs every bit in the memory array to the logic "1" state and is primarily used for testing purposes. The DO pin outputs the Ready/Busy status of the part if CS is brought high after being kept low for a minimum of 250 ns ( $t_{CS}$ ). The ERAL instruction is valid only at  $V_{CC} = 5.0V \pm 10\%$ .

**WRITE ALL (WRAL):** The Write All (WRAL) instruction programs all memory locations with the data patterns specified in the instruction. The DO pin outputs the Ready/Busy status of the part if CS is brought high after being kept low for a minimum of 250 ns ( $t_{CS}$ ). The WRAL instruction is valid only at  $V_{CC} = 5.0V \pm 10\%$ .

**ERASE/WRITE DISABLE (EWDS):** To protect against accidental data disturbance, the Erase/Write Disable (EWDS) instruction disables all programming modes and should be executed after all programming operations. The operation of the READ instruction is independent of both the EWEN and EWDS instructions and can be executed at any time.

## Timing Diagrams

**Figure 2.** Synchronous Data Timing

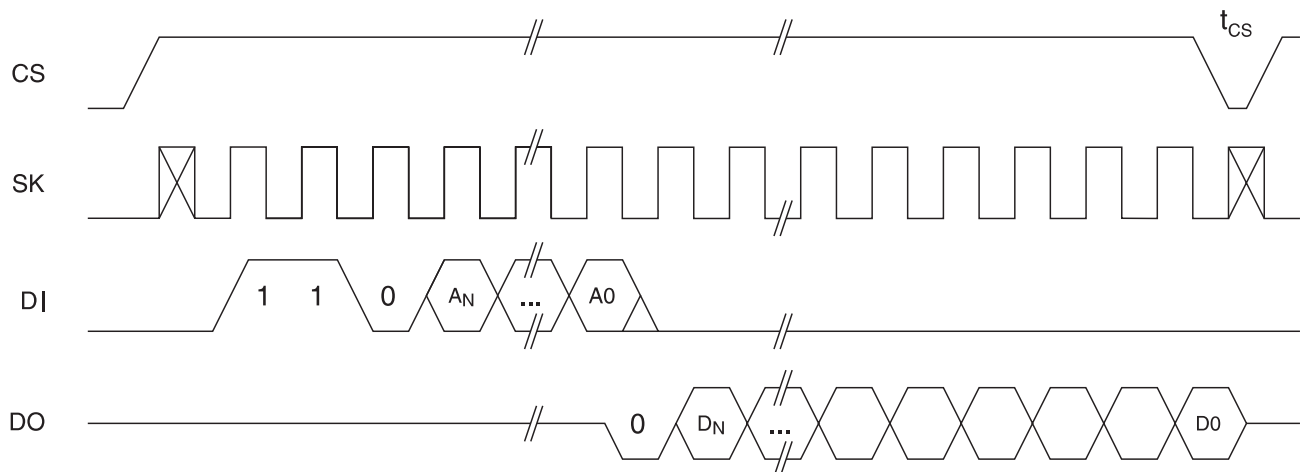


Note: 1. This is the minimum SK period.

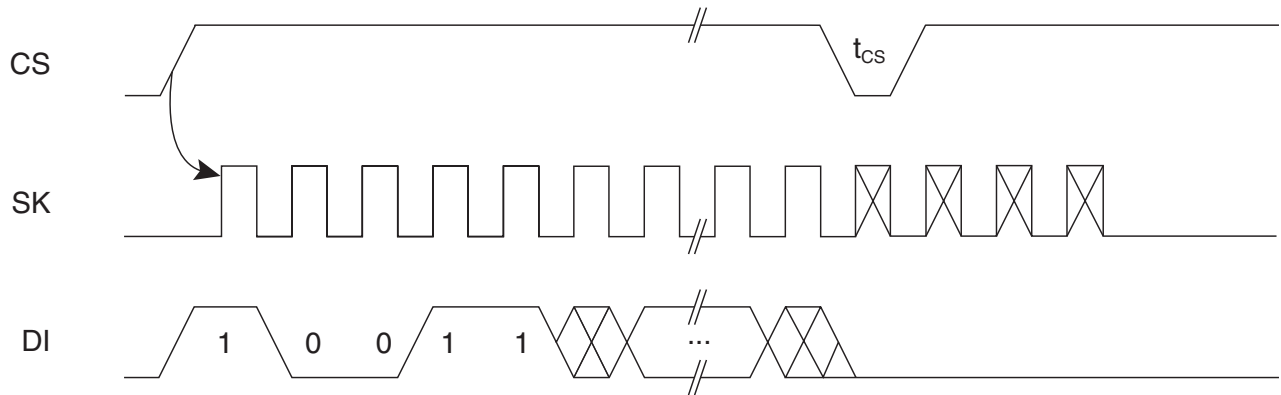
## Organization Key for Timing Diagrams

I/O	AT93C86A (16K)	
	x 8	x 16
$A_N$	$A_{10}$	$A_9$
$D_N$	$D_7$	$D_{15}$

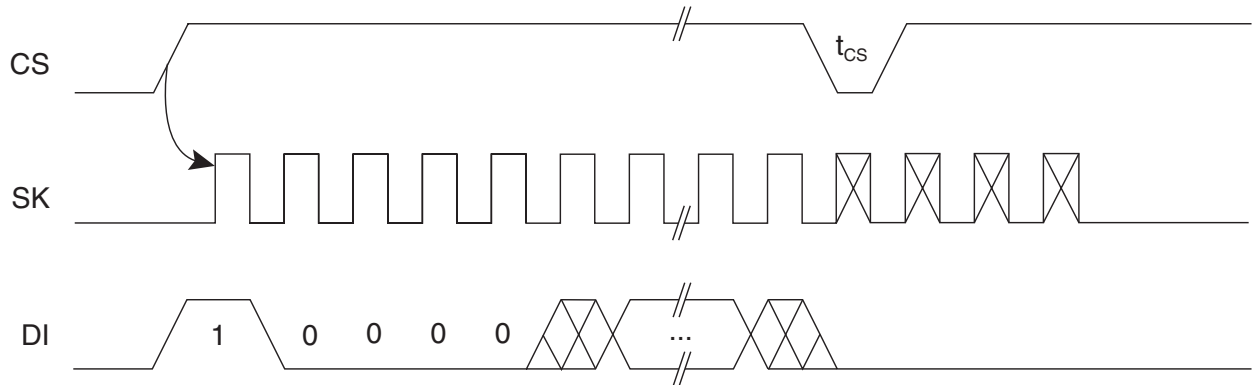
**Figure 3.** READ Timing



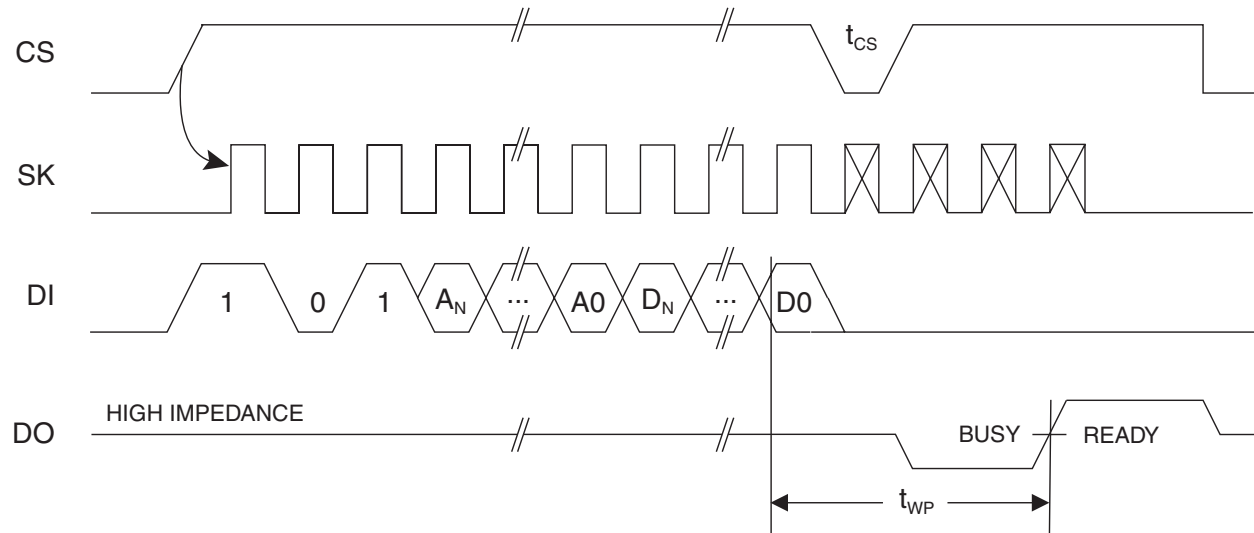
**Figure 4. EWEN Timing**



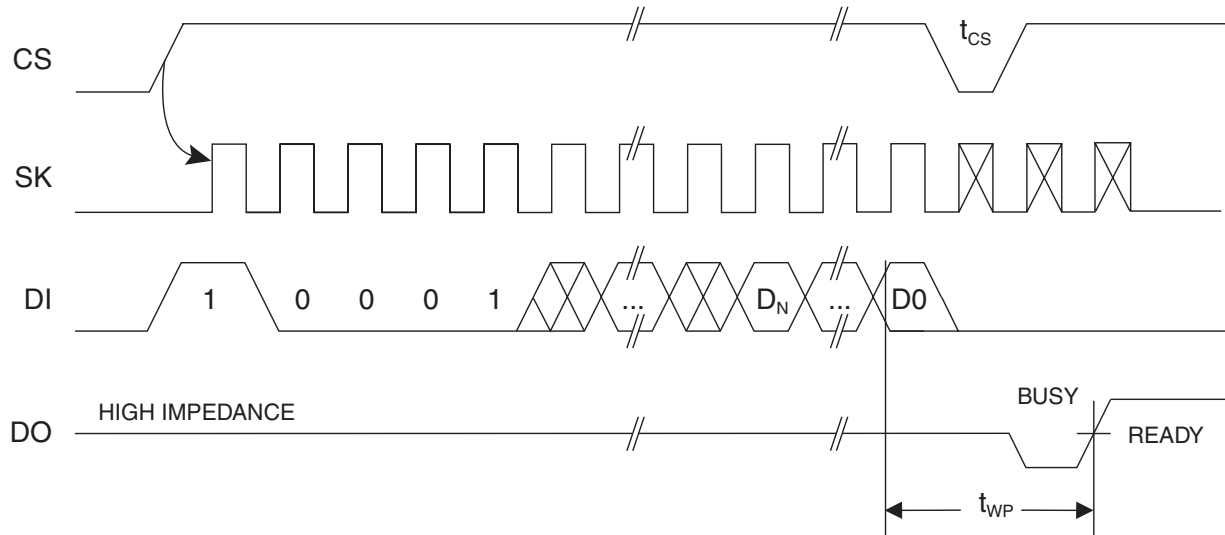
**Figure 5. EWDS Timing**



**Figure 6. WRITE Timing**

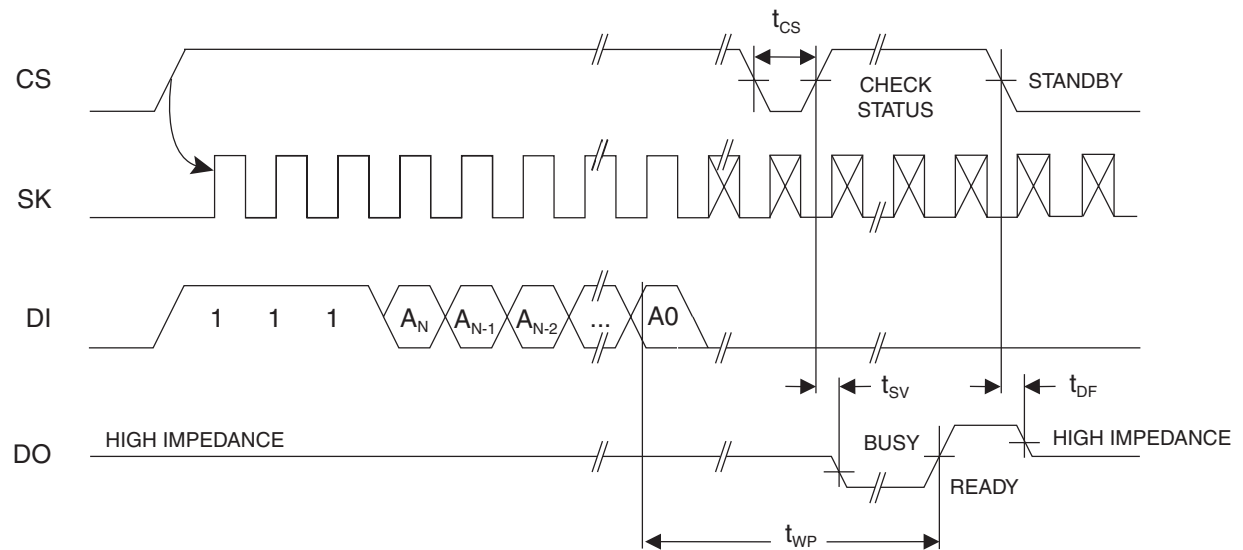


**Figure 7. WRAL Timing<sup>(1)</sup>**

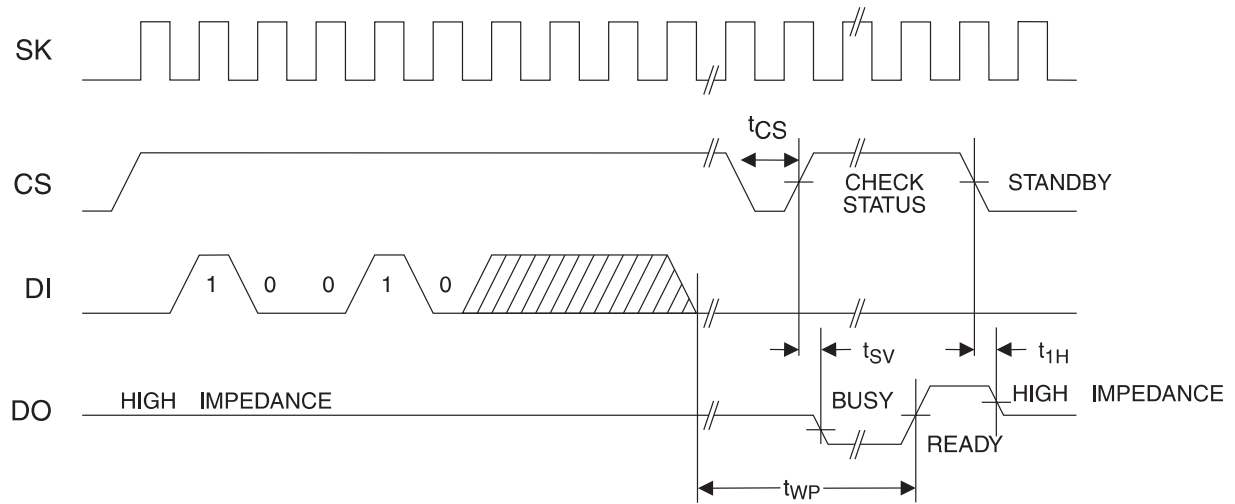


Note: 1. Valid only at  $V_{CC} = 4.5V$  to  $5.5V$ .

**Figure 8. ERASE Timing**



**Figure 9.** ERAL Timing<sup>(1)</sup>



Note: 1. Valid only at  $V_{CC} = 4.5V$  to  $5.5V$ .

## AT93C86A Ordering Information<sup>(1)</sup>

Ordering Code	Package	Operation Range
AT93C86A-10PU-2.7 <sup>(2)</sup>	8P3	Lead-Free/Halogen-Free/ Industrial Temperature (-40°C to 85°C)
AT93C86A-10PU-1.8 <sup>(2)</sup>	8P3	
AT93C86A-10SU-2.7 <sup>(2)</sup>	8S1	
AT93C86A-10SU-1.8 <sup>(2)</sup>	8S1	
AT93C86A-10TU-2.7 <sup>(2)</sup>	8A2	
AT93C86A-10TU-1.8 <sup>(2)</sup>	8A2	
AT93C86AY1-10YU-1.8 <sup>(2)</sup> (Not recommended for new design)	8Y1	
AT93C86AY6-10YH-1.8 <sup>(3)</sup>	8Y6	
AT93C86A-W1.8-11 <sup>(4)</sup>	Die Sale	Industrial Temperature (-40°C to 85°C)

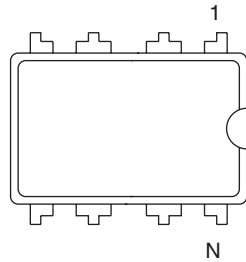
- Notes:
1. For 2.7V devices used in a 4.5V to 5.5V range, please refer to performance values in the AC and DC characteristics tables.
  2. "U" designates Green package + RoHS compliant.
  3. "H" designates Green Package + RoHS compliant, with NiPdAu Lead Finish.
  4. Available in Waffle pack and Wafer form; order as SL788 for inkless Wafer form. Bumped die available upon request. Please contact Serial EEPROM marketing.

Package Type	
<b>8P3</b>	8-lead, 0.300" Wide, Plastic Dual Inline Package (PDIP)
<b>8S1</b>	8-lead, 0.150" Wide, Plastic Gull Wing Small Outline (JEDEC SOIC)
<b>8A2</b>	8-lead, 0.170" Wide, Thin Shrink Small Outline Package (TSSOP)
<b>8Y1</b>	8-lead, 4.90 mm x 3.00 mm Body, Dual Footprint, Non-leaded, Miniature Array Package (MAP)
<b>8Y6</b>	8-lead, 2.00 mm x 3.00 mm Body, 0.50 mm Pitch, Ultra Thin Mini-MAP, Dual No Lead Package (DFN), (MLP 2x3 mm)
Options	
<b>-2.7</b>	Low Voltage (2.7V to 5.5V)
<b>-1.8</b>	Low Voltage (1.8V to 5.5V)

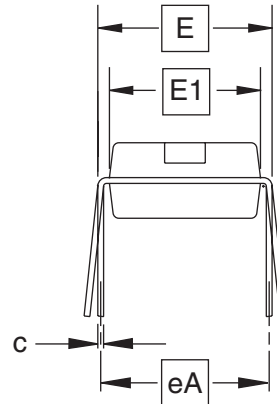


## Packaging Information

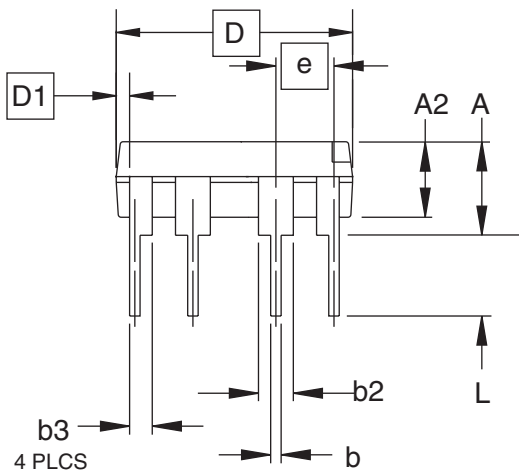
### 8P3 – PDIP



Top View



End View



Side View

**COMMON DIMENSIONS**  
(Unit of Measure = inches)

SYMBOL	MIN	NOM	MAX	NOTE
A			0.210	2
A2	0.115	0.130	0.195	
b	0.014	0.018	0.022	5
b2	0.045	0.060	0.070	6
b3	0.030	0.039	0.045	6
c	0.008	0.010	0.014	
D	0.355	0.365	0.400	3
D1	0.005			3
E	0.300	0.310	0.325	4
E1	0.240	0.250	0.280	3
e	0.100 BSC			
eA	0.300 BSC			4
L	0.115	0.130	0.150	2

- Notes:
1. This drawing is for general information only; refer to JEDEC Drawing MS-001, Variation BA for additional information.
  2. Dimensions A and L are measured with the package seated in JEDEC seating plane Gauge GS-3.
  3. D, D1 and E1 dimensions do not include mold Flash or protrusions. Mold Flash or protrusions shall not exceed 0.010 inch.
  4. E and eA measured with the leads constrained to be perpendicular to datum.
  5. Pointed or rounded lead tips are preferred to ease insertion.
  6. b2 and b3 maximum dimensions do not include Dambar protrusions. Dambar protrusions shall not exceed 0.010 (0.25 mm).

01/09/02



2325 Orchard Parkway  
San Jose, CA 95131

**TITLE**

**8P3**, 8-lead, 0.300" Wide Body, Plastic Dual  
In-line Package (PDIP)

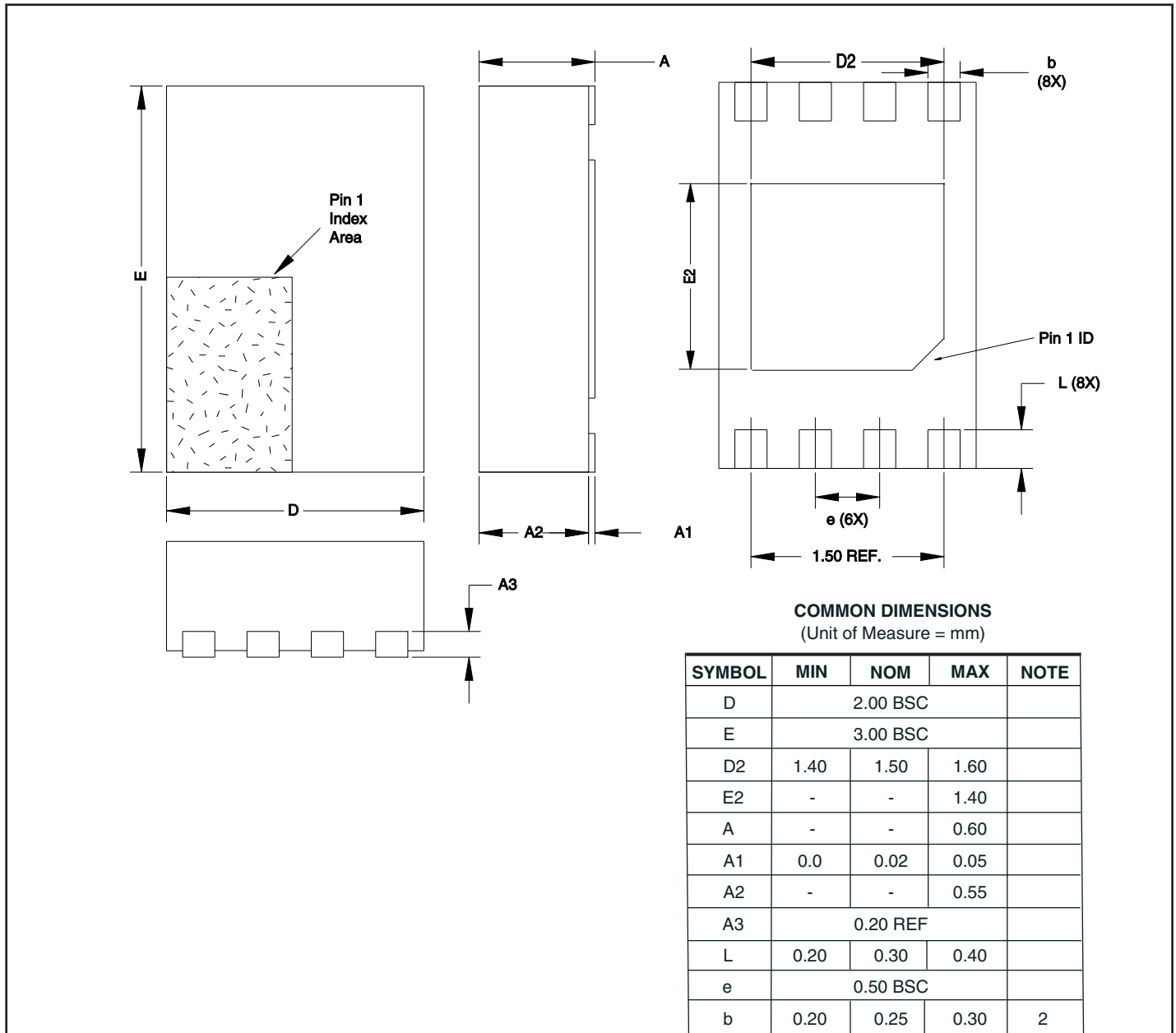
**DRAWING NO.**

8P3

**REV.**

B

## 8Y6 - MLP 2x3 mm



- Notes:
1. This drawing is for general information only. Refer to JEDEC Drawing MO-229, for proper dimensions, tolerances, datums, etc.
  2. Dimension b applies to metallized terminal and is measured between 0.15 mm and 0.30 mm from the terminal tip. If the terminal has the optional radius on the other end of the terminal, the dimension should not be measured in that radius area.

8/26/05



2325 Orchard Parkway  
San Jose, CA 95131

**TITLE**

**8Y6**, 8-lead 2.0 x 3.0 mm Body, 0.50 mm Pitch, Ultra Thin Mini-Map, Dual No Lead Package (DFN) ,(MLP 2x3)

**DRAWING NO.**

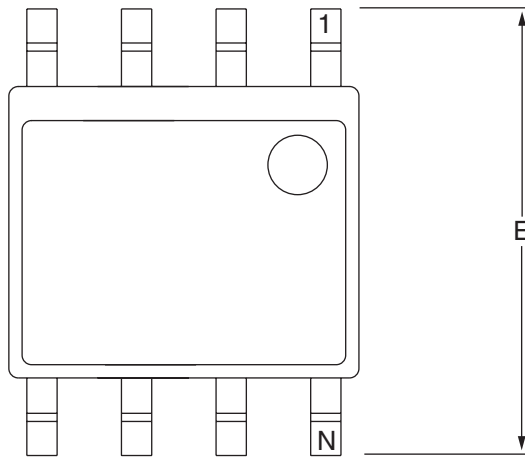
8Y6

**REV.**

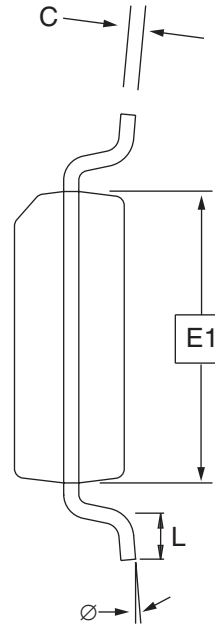
C



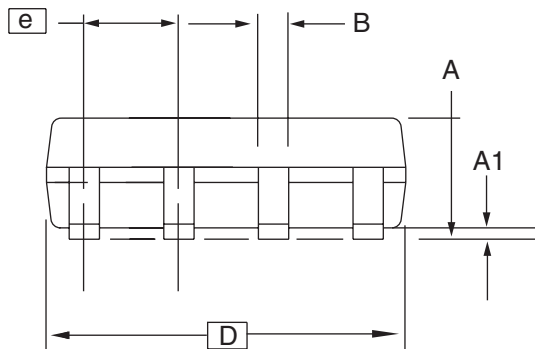
**8S1 – JEDEC SOIC**



Top View



End View



Side View

**COMMON DIMENSIONS**  
(Unit of Measure = mm)

SYMBOL	MIN	NOM	MAX	NOTE
A	1.35	–	1.75	
A1	0.10	–	0.25	
B	0.31	–	0.51	
C	0.17	–	0.25	
D	4.80	–	5.00	
E1	3.81	–	3.99	
E	5.79	–	6.20	
e	1.27 BSC			
L	0.40	–	1.27	
∅	0°	–	8°	

Note: These drawings are for general information only. Refer to JEDEC Drawing MS-012, Variation AA for proper dimensions, tolerances, datums, etc.

10/7/03



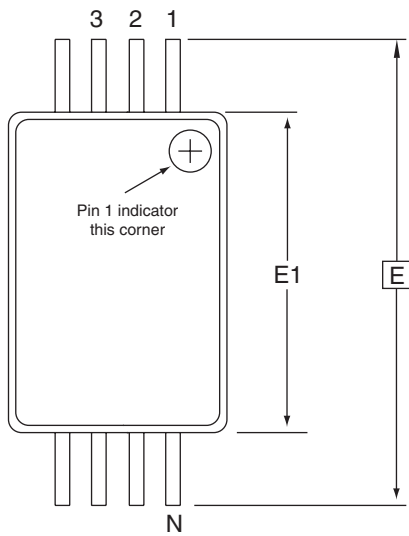
1150 E. Cheyenne Mtn. Blvd.  
Colorado Springs, CO 80906

**TITLE**  
**8S1**, 8-lead (0.150" Wide Body), Plastic Gull Wing  
Small Outline (JEDEC SOIC)

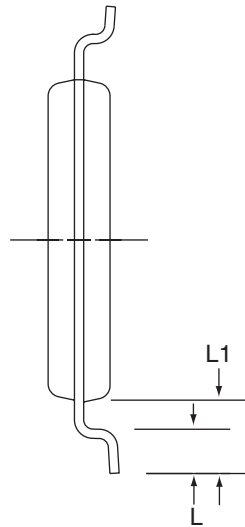
**DRAWING NO.**  
8S1

**REV.**  
B

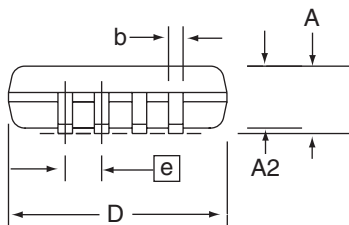
## 8A2 – TSSOP



Top View



End View



Side View

### COMMON DIMENSIONS (Unit of Measure = mm)

SYMBOL	MIN	NOM	MAX	NOTE
D	2.90	3.00	3.10	2, 5
E	6.40 BSC			
E1	4.30	4.40	4.50	3, 5
A	-	-	1.20	
A2	0.80	1.00	1.05	
b	0.19	-	0.30	4
e	0.65 BSC			
L	0.45	0.60	0.75	
L1	1.00 REF			

- Notes:
1. This drawing is for general information only. Refer to JEDEC Drawing MO-153, Variation AA, for proper dimensions, tolerances, datums, etc.
  2. Dimension D does not include mold Flash, protrusions or gate burrs. Mold Flash, protrusions and gate burrs shall not exceed 0.15 mm (0.006 in) per side.
  3. Dimension E1 does not include inter-lead Flash or protrusions. Inter-lead Flash and protrusions shall not exceed 0.25 mm (0.010 in) per side.
  4. Dimension b does not include Dambar protrusion. Allowable Dambar protrusion shall be 0.08 mm total in excess of the b dimension at maximum material condition. Dambar cannot be located on the lower radius of the foot. Minimum space between protrusion and adjacent lead is 0.07 mm.
  5. Dimension D and E1 to be determined at Datum Plane H.

5/30/02



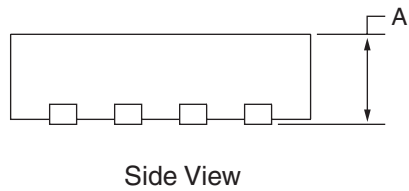
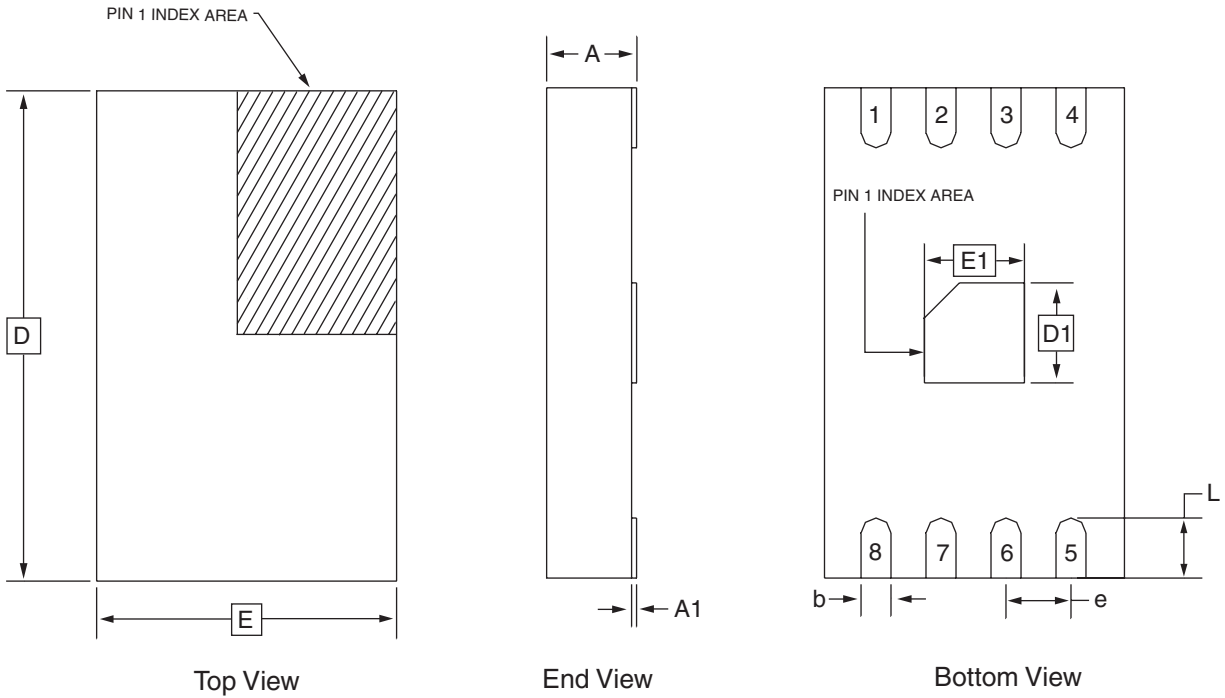
2325 Orchard Parkway  
San Jose, CA 95131

**TITLE**  
**8A2**, 8-lead, 4.4 mm Body, Plastic  
Thin Shrink Small Outline Package (TSSOP)

**DRAWING NO.**  
8A2

**REV.**  
B

# 8Y1 - MAP



**COMMON DIMENSIONS**  
(Unit of Measure = mm)

SYMBOL	MIN	NOM	MAX	NOTE
A	-	-	0.90	
A1	0.00	-	0.05	
D	4.70	4.90	5.10	
E	2.80	3.00	3.20	
D1	0.85	1.00	1.15	
E1	0.85	1.00	1.15	
b	0.25	0.30	0.35	
e	0.65 TYP			
L	0.50	0.60	0.70	

2/28/03



2325 Orchard Parkway  
San Jose, CA 95131

**TITLE**

**8Y1**, 8-lead (4.90 x 3.00 mm Body) MSOP Array Package  
(MAP) Y1

**DRAWING NO.**

8Y1

**REV.**

C

## Revision History

<b>Doc. Rev.</b>	<b>Date</b>	<b>Comments</b>
3408H	1/2007	Add "Bottom View" to pg 1 Ultra Thin MiniMap package drawing pg 4 revise Note 1 added "ensured by characterization"
3408G	7/2006	Revision history implemented. Deleted 'Preliminary' status from datasheet; Added 'Ultra Thin' description to MLP 2x3 package; Deleted '1.8V not available' on Figure 1 Note; Added 1.8V range on Table 4 under Write Cycle Time.



## Atmel Corporation

2325 Orchard Parkway  
San Jose, CA 95131, USA  
Tel: 1(408) 441-0311  
Fax: 1(408) 487-2600

## Regional Headquarters

### Europe

Atmel Sarl  
Route des Arsenalux 41  
Case Postale 80  
CH-1705 Fribourg  
Switzerland  
Tel: (41) 26-426-5555  
Fax: (41) 26-426-5500

### Asia

Room 1219  
Chinachem Golden Plaza  
77 Mody Road Tsimshatsui  
East Kowloon  
Hong Kong  
Tel: (852) 2721-9778  
Fax: (852) 2722-1369

### Japan

9F, Tonetsu Shinkawa Bldg.  
1-24-8 Shinkawa  
Chuo-ku, Tokyo 104-0033  
Japan  
Tel: (81) 3-3523-3551  
Fax: (81) 3-3523-7581

## Atmel Operations

### Memory

2325 Orchard Parkway  
San Jose, CA 95131, USA  
Tel: 1(408) 441-0311  
Fax: 1(408) 436-4314

### Microcontrollers

2325 Orchard Parkway  
San Jose, CA 95131, USA  
Tel: 1(408) 441-0311  
Fax: 1(408) 436-4314

La Chantrerie  
BP 70602  
44306 Nantes Cedex 3, France  
Tel: (33) 2-40-18-18-18  
Fax: (33) 2-40-18-19-60

### ASIC/ASSP/Smart Cards

Zone Industrielle  
13106 Rousset Cedex, France  
Tel: (33) 4-42-53-60-00  
Fax: (33) 4-42-53-60-01

1150 East Cheyenne Mtn. Blvd.  
Colorado Springs, CO 80906, USA  
Tel: 1(719) 576-3300  
Fax: 1(719) 540-1759

Scottish Enterprise Technology Park  
Maxwell Building  
East Kilbride G75 0QR, Scotland  
Tel: (44) 1355-803-000  
Fax: (44) 1355-242-743

### RF/Automotive

Theresienstrasse 2  
Postfach 3535  
74025 Heilbronn, Germany  
Tel: (49) 71-31-67-0  
Fax: (49) 71-31-67-2340

1150 East Cheyenne Mtn. Blvd.  
Colorado Springs, CO 80906, USA  
Tel: 1(719) 576-3300  
Fax: 1(719) 540-1759

### Biometrics/Imaging/Hi-Rel MPU/ High Speed Converters/RF Datacom

Avenue de Rochepleine  
BP 123  
38521 Saint-Egreve Cedex, France  
Tel: (33) 4-76-58-30-00  
Fax: (33) 4-76-58-34-80

---

## Literature Requests

[www.atmel.com/literature](http://www.atmel.com/literature)

**Disclaimer:** The information in this document is provided in connection with Atmel products. No license, express or implied, by estoppel or otherwise, to any intellectual property right is granted by this document or in connection with the sale of Atmel products. **EXCEPT AS SET FORTH IN ATMEL'S TERMS AND CONDITIONS OF SALE LOCATED ON ATMEL'S WEB SITE, ATMEL ASSUMES NO LIABILITY WHATSOEVER AND DISCLAIMS ANY EXPRESS, IMPLIED OR STATUTORY WARRANTY RELATING TO ITS PRODUCTS INCLUDING, BUT NOT LIMITED TO, THE IMPLIED WARRANTY OF MERCHANTABILITY, FITNESS FOR A PARTICULAR PURPOSE, OR NON-INFRINGEMENT. IN NO EVENT SHALL ATMEL BE LIABLE FOR ANY DIRECT, INDIRECT, CONSEQUENTIAL, PUNITIVE, SPECIAL OR INCIDENTAL DAMAGES (INCLUDING, WITHOUT LIMITATION, DAMAGES FOR LOSS OF PROFITS, BUSINESS INTERRUPTION, OR LOSS OF INFORMATION) ARISING OUT OF THE USE OR INABILITY TO USE THIS DOCUMENT, EVEN IF ATMEL HAS BEEN ADVISED OF THE POSSIBILITY OF SUCH DAMAGES.** Atmel makes no representations or warranties with respect to the accuracy or completeness of the contents of this document and reserves the right to make changes to specifications and product descriptions at any time without notice. Atmel does not make any commitment to update the information contained herein. Unless specifically provided otherwise, Atmel products are not suitable for, and shall not be used in, automotive applications. Atmel's products are not intended, authorized, or warranted for use as components in applications intended to support or sustain life.

© 2007 Atmel Corporation. All rights reserved. Atmel®, logo and combinations thereof, Everywhere You Are® and others, are registered trademarks or trademarks of Atmel Corporation or its subsidiaries. Other terms and product names may be trademarks of others.



Printed on recycled paper.

3408H-SEEPR-1/07