



## MKV AC capacitors

Damping, Commutating

Ordering code: **B25838**  
Date: September 2005

© EPCOS AG 2005. Reproduction, publication and dissemination of this data sheet, enclosures hereto and the information contained therein without EPCOS' prior express consent is prohibited.



**Damping**

**Features**

- High dielectric strength
- High peak-current capability

**Applications**

- For damping and commutating in the upper frequency range

**Construction**

- Self-healing
- Plastic dielectric
- Oil-impregnated tubular windings (no PCB)
- Metal-sprayed end faces ensure reliable contacting
- Cylindrical aluminum case
- Ceramic lead-throughs
- Mounting bolts M8 or M12



**Terminals**

- Screw terminals M10
- Tab connectors 6.3 mm
- Dual tab connectors 6.3 mm

**Mounting**

- If the vibration stress is  $\leq 5 g$  and the capacitors are  $\leq 60$  mm in diameter and  $\leq 160$  mm in height the bolt is used for mounting.

**Grounding**

- Mounting bolt for grounding in accordance with VDE 0100
- Grounding identification in accordance with DIN 40 011

**Individual data sheets**

Individual data sheets contain detailed specification incl. thermal data. Upon request, these data sheets are available for each capacitor type.



Damping

Technical data

Standards		IEC 1071-1/2 EN 61071-1/2 VDE 0560 part 120 and 121
Dielectric dissipation factor	$\tan \delta_0$	$2 \cdot 10^{-4}$
Capacitance tolerance		$\pm 10\%$
Max. repetitive rate of voltage rise	$(dv/dt)_{\max}$	$\frac{\hat{v}}{C}$
Max. non-repetitive rate of voltage rise	$(dv/dt)_s$	$\frac{I_s}{C}$
Climatic data:		
Min. operating temperature	$T_{\min}$	$- 25 \text{ }^\circ\text{C}$
Max. operating temperature	$T_{\max}$	$+ 85 \text{ }^\circ\text{C}$
Average relative humidity		$\leq 95 \%$
Failure quota	$\alpha_{\text{FQ}(\text{co})}$	300 failures per $10^9$ component hours
Load duration	$t_{\text{LD}(\text{co})}$	100 000 h
Storage temperature limit	$T_{\text{stg}}$	$- 55/+ 85 \text{ }^\circ\text{C}$
IEC climatic category (IEC 68-1 and 2)		25/085/56
Test data:		
AC test voltage		
between terminals	$V_{\text{TT}}$	$1,25 \cdot V_{\text{R}}, 50 \text{ Hz}, 10 \text{ s}$ (or DC $1.75 \times V_{\text{R}}, 10 \text{ s}$ )
between terminals and case	$V_{\text{TC}}$	$2 \cdot V_i + 1000 \text{ V}, 50 \text{ Hz}, 10 \text{ s}$ Insulating voltage $V_i = \text{max. recurrent peak voltage } \hat{v} / \sqrt{2}$
Insulation resistance	$R_{\text{ins}}$	$C_{\text{R}} \leq 1 \text{ } \mu\text{F}: \geq 10 \text{ 000 M}\Omega$
Self-discharge time constant	$\tau = R_{\text{ins}} \cdot C$	$C_{\text{R}} > 1 \text{ } \mu\text{F}: \geq 10 \text{ 000 s}$
Dissipation factor (50 Hz)	$\tan \delta$	$\leq 3 \cdot 10^{-4}$



**MKV AC Capacitors**
**B25838**
**Damping**
**Characteristics and ordering codes**

$C_R^{1)}$	$I_{max}$	$\hat{i}$	$I_s$	$R_{ins}$ 20 °C	$L_{self}$	Dimensions $d \times l$	Fig.	Appr. weight	Ordering code
$\mu F$	A	A	A	m $\Omega$	nH	mm		g	
<b><math>V_R = AC 600 V</math></b>				$\hat{v} = 750 V$ $v_s = 1000 V$		$V_{TT} = AC 750 V, 10 s$ $V_{TC} = AC 2100 V, 10 s$			
2.2	20	350	880	8.0	60	40.0 × 57	3	90	B25838K4225K001
4.7	40	750	1900	4.5	70	40.0 × 95	2	140	B25838K4475K009
10	80	1600	4000	2.4	90	64.2 × 115	1	450	B25838L4106K004
15	80	2400	6000	2.2	140	79.2 × 194	1	1100	B25838L4156K004
22	80	3500	8800	1.7	140	79.2 × 194	1	1100	B25838L4226K004
33	80	5300	13000	1.4	140	79.2 × 194	1	1100	B25838L4336K004
47	80	7500	19000	1.1	140	79.2 × 194	1	1100	B25838L4476K004
<b><math>V_R = AC 900 V</math></b>				$\hat{v} = 1100 V$ $v_s = 1500 V$		$V_{TT} = AC 1150 V, 10 s$ $V_{TC} = AC 2600 V, 10 s$			
1.0	20	280	700	9.6	60	40.0 × 57	3	90	B25838K6105K001
2.2	20	620	1500	4.9	60	50.0 × 57	3	130	B25838K6225K001
4.7	40	1300	3300	3.1	70	50.0 × 95	2	220	B25838K6475K009
6.8	80	1900	4800	2.0	90	64.2 × 115	1	450	B25838L6685K004
10	80	2800	7000	1.9	140	79.2 × 194	1	1100	B25838L6106K004
12	80	3400	8400	1.7	140	79.2 × 194	1	1100	B25838L6126K004
15	80	4200	10500	1.5	140	79.2 × 194	1	1100	B25838L6156K004
22	80	6200	15000	1.2	140	79.2 × 194	1	1100	B25838L6226K004
33	80	9200	23000	1.1	140	89.3 × 194	1	1500	B25838L6336K004
<b><math>V_R = AC 1100 V</math></b>				$\hat{v} = 1400 V$ $v_s = 1900 V$		$V_{TT} = AC 1400 V, 10 s$ $V_{TC} = AC 3000 V, 10 s$			
1,0	20	600	1500	13,0	90	40,0 × 95	3	140	B25838K8105K001
2,2	20	1300	3300	6,5	70	50,0 × 95	3	220	B25838K8225K001
4,7	80	2800	7000	3,5	170	64,2 × 194	1	750	B25838L8475K004
10	80	6000	15000	2,1	170	79,2 × 194	1	1100	B25838L8106K004
12	80	7200	18000	2,0	170	89,3 × 194	1	1500	B25838L8126K004
15	80	9000	23000	1,7	170	89,3 × 194	1	1500	B25838L8156K004
18	80	11000	27000	1,5	170	89,3 × 194	1	1500	B25838L8186K004
22	80	13000	33000	1,4	170	89,3 × 194	1	1500	B25838L8226K004

1) Other capacitance values upon request

**Dimensional drawing 1**

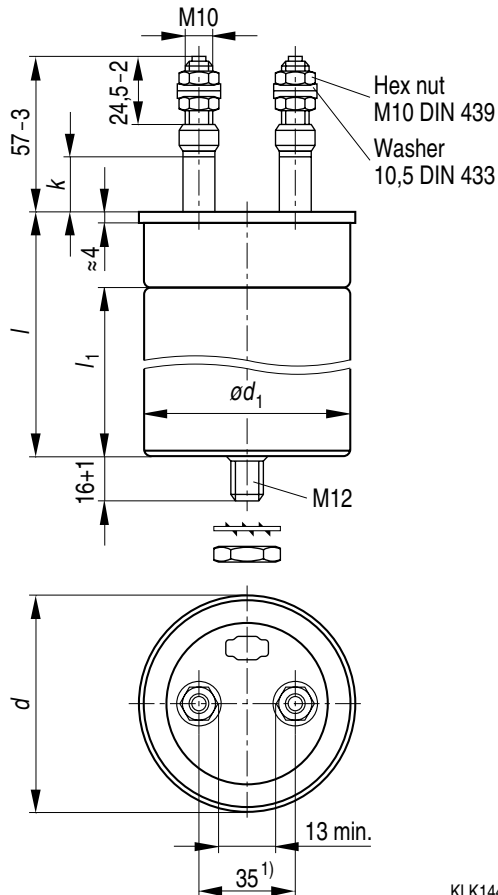
Screw terminals M10



KLK1440-3

Dimensions in mm

$d-1,2$	$l-4$	$\varnothing d_1-0,4$	$l_1 \text{ min}$	Creepage distance $k$	Clearance
64.2	115	60.2	78	20	13
64.2	194	60.2	150	20	13
79.2	194	75.2	150	20	13
89.3	194	85.2	150	20	13
Max. torque terminals*)				7 Nm	

**Dimensional drawing 2**

Dual tab connectors 6.3 mm

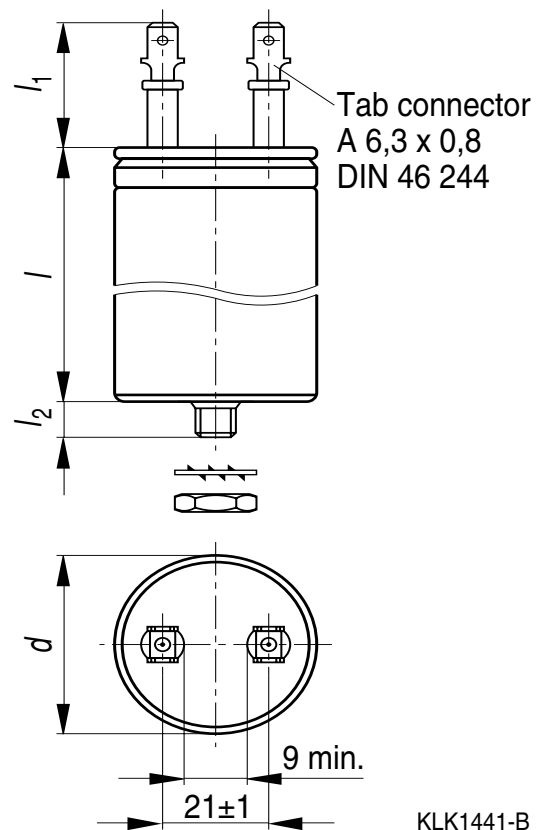

KLK1441-B

Dimensions in mm

$d_{-0,2}^{+0,5}$	$l_{-2}^{+1}$	$l_1 \text{ max}$	$l_2 + 1^{**}$	Creepage distance	Clearance
40	95	28	8	10	9
50	95	32	12	14	9

\*\*) 8 mm = threaded bolt M8  
12 mm = threaded bolt M12

\*) The terminal torque must not act upon the ceramic. So the lead should be locked between to nuts.

1) Dimensions only for orientation, subject for modifications

**Mounting parts (included in delivery)**

Threaded bolt	Max. torque	Toothed washer	Hex nut
M8	4 Nm	J 8.2 DIN 6797	M 8 DIN 439
M12	10 Nm	J 12.5 DIN 6797	M12 DIN 439

**Dimensional drawing 3**

Tab connectors 6.3 mm

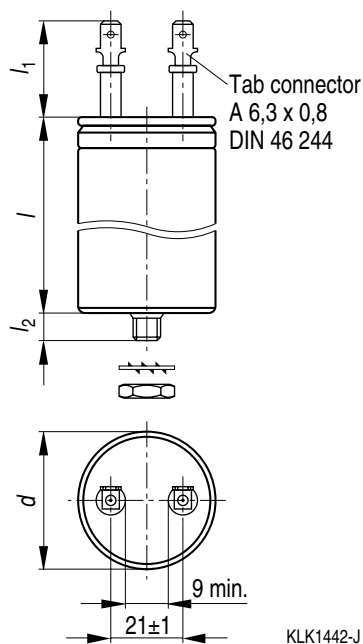

Dimensions in mm

$d_{-0,2}^{+0,5}$	$l_{-2}^{+1}$	$l_1 \text{ max}$	$l_2 + 1^*)$	Creepage distance	Clearance
40	57	28	8	10 <sup>**)</sup>	9
40	57	32	8	14	9
40	95	32	8	14	9
50	57	32	12	14	9
50	95	32	12	14	9

\*) 8 mm = threaded bolt M8, 12 mm = threaded bolt M12

\*\*) Type B25838K4225K001

**Mounting parts (included in delivery)**

Threaded bolt	Max. torque	Toothed washer	Hex nut
M8	4 Nm	J 8,2 DIN 6797	M 8 DIN 439
M12	10 Nm	J 12,5 DIN 6797	M 12 DIN 439



## Cautions and warnings

### Safety

- In case of dents of more than 1 mm depth or any other mechanical damage, capacitors must not be used at all. This applies also in cases of oil leakage.
- Electrical or mechanical misapplication of capacitors may be hazardous. Personal injury or property damage may result from bursting of the capacitor or from expulsion of oil or melted material due to mechanical disruption of the capacitor.
- Ensure good, effective grounding for capacitor enclosures.
- Observe appropriate safety precautions during operation (self-recharging phenomena and the high energy contained in capacitors).
- Handle capacitors carefully, because they may still be charged even after disconnection.
- The terminals of capacitors, connected bus bars and cables as well as other devices may also be energized.
- Follow good engineering practice.
- Failure to follow cautions may result, worst case, in premature failures, bursting and fire.

### Thermal load

After installation of the capacitor it is necessary to verify that maximum hot-spot temperature is not exceeded at extreme service conditions (see [www.epcos.com/thermal\\_design](http://www.epcos.com/thermal_design)).

### Mechanical protection

The capacitor has to be installed in a way that mechanical damages and dents in the aluminum can be avoided.

### Storage and operating conditions

Do not use or store capacitors in corrosive atmosphere especially where chloride gas, sulfide gas, acid, alkali, salt or the like are present. In dusty environments, regular maintenance and cleaning especially of the terminals is required to avoid conductive path between phases and/or phases and ground.

### Overpressure disconnecter

To ensure full functionality of an overpressure disconnecter, the following must be observed:

- The elastic elements must not be hindered, i.e.
  - connecting lines must be flexible leads (cables),
  - there must be sufficient space (minimum 12 mm) above the connections for expansion of the overpressure disconnecter,
  - folding crimps must not be retained by clamps.
- Stress parameters of the capacitor must be within the IEC61071 specification.

### Service life expectancy

Electrical components do not have an unlimited service life expectancy; this applies to self-healing capacitors too. The maximum service life expectancy may vary depending on the application the capacitor is used in.



## Important notes

The following applies to all products named in this publication:

1. Some parts of this publication contain **statements about the suitability of our products for certain areas of application**. These statements are based on our knowledge of typical requirements that are often placed on our products in the areas of application concerned. We nevertheless expressly point out **that such statements cannot be regarded as binding statements about the suitability of our products for a particular customer application**.  
As a rule, EPCOS is either unfamiliar with individual customer applications or less familiar with them than the customers themselves. For these reasons, it is always ultimately incumbent on the customer to check and decide whether an EPCOS product with the properties described in the product specification is suitable for use in a particular customer application.
2. We also point out that **in individual cases, a malfunction of passive electronic components or failure before the end of their usual service life cannot be completely ruled out in the current state of the art, even if they are operated as specified**. In customer applications requiring a very high level of operational safety and especially in customer applications in which the malfunction or failure of a passive electronic component could endanger human life or health (e.g. in accident prevention or life-saving systems), it must therefore be ensured by means of suitable design of the customer application or other action taken by the customer (e.g. installation of protective circuitry or redundancy) that no injury or damage is sustained by third parties in the event of malfunction or failure of a passive electronic component.
3. **The warnings, cautions and product-specific notes must be observed.**
4. In order to satisfy certain technical requirements, **some of the products described in this publication may contain substances subject to restrictions in certain jurisdictions (e.g. because they are classed as “hazardous”)**. Useful information on this will be found in our Material Data Sheets on the Internet ([www.epcos.com/material](http://www.epcos.com/material)). Should you have any more detailed questions, please contact our sales offices.
5. We constantly strive to improve our products. Consequently, **the products described in this publication may change from time to time**. The same is true of the corresponding product specifications. Please check therefore to what extent product descriptions and specifications contained in this publication are still applicable before or when you place an order.  
We also **reserve the right to discontinue production and delivery of products**. Consequently, we cannot guarantee that all products named in this publication will always be available.
6. Unless otherwise agreed in individual contracts, **all orders are subject to the current version of the “General Terms of Delivery for Products and Services in the Electrical Industry” published by the German Electrical and Electronics Industry Association (ZVEI)**.
7. The trade names EPCOS, CeraDiode, CSSP, PhaseCap, PhaseMod, SilverCap, SIFI, SIMID, SIKOREL, SIOV, SIP5D, SIP5K, TOPcap, UltraCap, WindCap are **trademarks registered or pending** in Europe and in other countries. Further information will be found on the Internet at [www.epcos.com/trademarks](http://www.epcos.com/trademarks).