



FEMTOCLOCKS™ CRYSTAL-TO-LVPECL 350MHZ FREQUENCY MARGINING SYNTHESIZER

ICS843207-350

GENERAL DESCRIPTION

The ICS843207-350 is a low phase-noise frequency margining synthesizer that targets clocking for high performance interfaces such as SPI4.2 and is a member of the HiPerClockS™ family of high performance clock solutions from IDT. In the default mode, each output can be configured individually to generate an 87.5MHz, 175MHz or 350MHz LVPECL output clock signal from a 14MHz crystal input. There is also a frequency margining mode available where the device can be configured, using control pins, to vary the output frequency up or down from nominal by 5%. The ICS843207-350 is provided in a 48-pin LQFP package.

FEATURES

- Seven independently configurable LVPECL outputs at 87.5MHz, 175MHz or 350MHz
- Individual high impedance control of each output
- Selectable crystal oscillator interface designed for 14MHz, 18pF parallel resonant crystal or LVCMOS single-ended input
- Output frequency can be varied $\pm 5\%$ from nominal
- VCO range: 620MHz - 750MHz
- Full 3.3V supply mode
- 0°C to 70°C ambient operating temperature
- Available in both standard (RoHS 5) and lead-free (RoHS 6) packages

PIN ASSIGNMENT

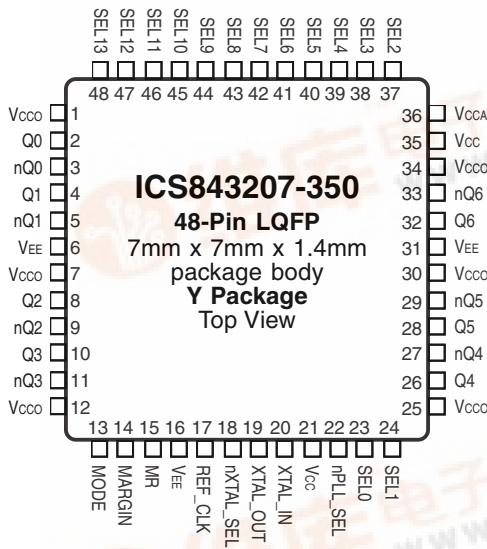

BLOCK DIAGRAM

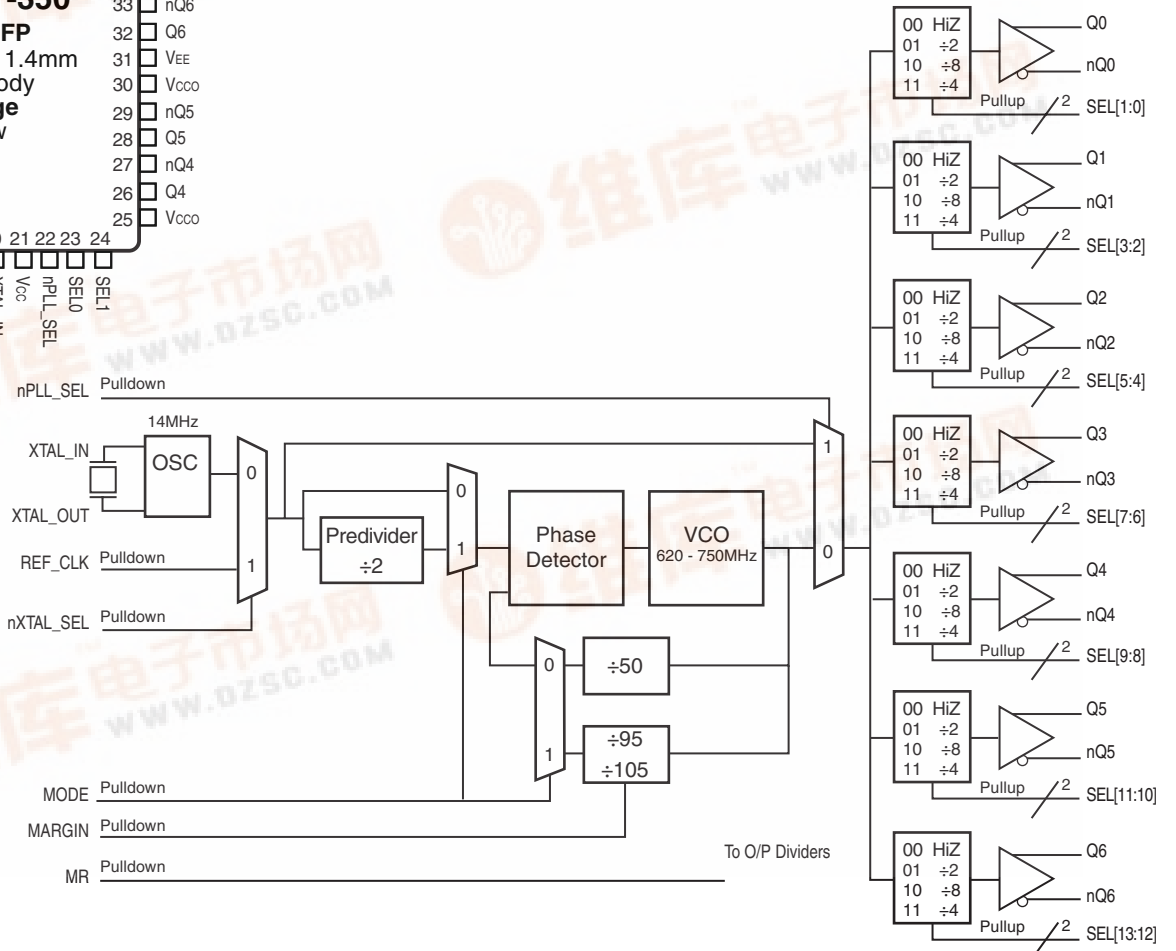

FUNCTIONAL DESCRIPTION

The ICS843207-350 features a fully integrated PLL and therefore requires no external components for setting the loop bandwidth. A 14MHz fundamental crystal is used as the input to the on chip oscillator. The output of the oscillator is fed into the pre-divider. In frequency margining mode, the 14MHz crystal frequency is divided by 2 and a 7MHz reference frequency is applied to the phase detector. The VCO of the PLL operates over a range of 620MHz to 750MHz. The output of the M divider is also applied to the phase detector. The default mode for the ICS843207-350 is a nominal VCO frequency of 700MHz with each output configurable to divide by 2, 4 or 8. The nominal output frequency can be changed by placing the device into the margining mode using the mode pin

and using the margin pin to change the M feedback divider. Frequency margining mode operation occurs when the MODE input is HIGH. The phase detector and the M divider force the VCO output frequency to be M times the reference frequency by adjusting the VCO control voltage. The output of the VCO is scaled by an output divider prior to being sent to the LVPECL output buffer. The divider provides a 50% output duty cycle. The relationship between the crystal input frequency, the M divider, the VCO frequency and the output frequency is provided in Table 1A. When changing back from frequency margining mode to nominal mode, the device will return to the default nominal configuration described above.

TABLE 1A. FREQUENCY SELECT FUNCTION TABLE

XTAL (MHz)	SELx	SELx-1	VCO (MHz)	Output Divider	Output Frequency (MHz)
14	0	0	700	N/A	HiZ
14	0	1	700	2	350
14	1	0	700	8	87.5
14	1	1	700	4	175

TABLE 1B. FREQUENCY MARGIN FUNCTION TABLE

MODE	MARGIN	XTAL (MHz)	Pre-Divider (P)	Feedback Divider	VCO (MHz)	% Change
1	0	14	2	95	665	-5.0
0	X	14	1	50	700	Nom. Mode
1	1	14	2	105	735	+5.0

TABLE 2. PIN DESCRIPTIONS

Number	Name	Type		Description
1, 7, 12, 25, 30, 34	V _{CCO}	Power		Output supply pins.
2, 3	Q0, nQ0	Ouput		Differential output pair. LVPECL interface levels.
4, 5	Q1, nQ1	Ouput		Differential output pair. LVPECL interface levels.
6, 16, 31	V _{EE}	Power		Negative supply pins.
8, 9	Q2, nQ2	Ouput		Differential output pair. LVPECL interface levels.
10, 11	Q3, nQ3	Ouput		Differential output pair. LVPECL interface levels.
13	MODE	Input	Pulldown	MODE pin. LOW = default mode. HIGH = frequency margining mode. See Table 4B. LVCMOS/LVTTL interface levels.
14	Margin	Input	Pulldown	Sets the frequency to ±5% in frequency margining mode. See Table 1B. LVCMOS/LVTTL interface levels.
15	MR	Input	Pulldown	Active High Master Reset. When logic HIGH, the internal dividers are reset causing the true outputs Qx to go LOW and inverted outputs nQx to go HIGH. When logic LOW, the internal dividers and the outputs are enabled. LVCMOS/LVTTL interface levels.
17	REF_CLK	Input	Pulldown	Reference input clock. LVCMOS/LVTTL interface levels.
18	nXTAL_SEL	Input	Pulldown	Crystal select pin. Selects between the crystal and the reference clock inputs. LVCMOS/LVTTL interface levels.
19, 20	XTAL_OUT, XTAL_IN	Input		Parallel resonant crystal interface. XTAL_OUT is the output, XTAL_IN is the input.
21, 35	V _{CC}	Power		Core supply pins.
22	nPLL_SEL	Input	Pulldown	PLL select pin. When HIGH, PLL is bypassed and input is fed directly to the output dividers. When LOW, PLL is enabled. LVCMOS/LVTTL interface levels.
23, 24, 37, 38, 39, 40, 41, 42, 43, 44, 45, 46, 47, 48	SEL0, SEL1, SEL2, SEL3, SEL4, SEL5, SEL6, SEL7, SEL8, SEL9, SEL10, SEL11, SEL12, SEL13	Input	Pullup	Output divider select pins. See Table 1A. LVCMOS/LVTTL interface levels.
26, 27	Q4, nQ4	Ouput		Differential output pair. LVPECL interface levels.
28, 29	Q5, nQ5	Ouput		Differential output pair. LVPECL interface levels.
32, 33	Q6, nQ6	Ouput		Differential output pair. LVPECL interface levels.
36	V _{CCA}	Power		Analog supply pin.

NOTE: *Pullup and Pulldown* refer to internal input resistors. See Table 2, Pin Characteristics, for typical values.

TABLE 3. PIN CHARACTERISTICS

Symbol	Parameter	Test Conditions	Minimum	Typical	Maximum	Units
C _{IN}	Input Capacitance			4		pF
R _{PULLDOWN}	Input Pulldown Resistor			51		kΩ
R _{PULLUP}	Input Pulldown Resistor			51		kΩ

TABLE 4A. nXTAL_SEL CONTROL INPUT FUNCTION TABLE

Input	
nXTAL_SEL	Selected Source
0	XTAL_IN, XTAL_OUT
1	REF_CLK

TABLE 4B. MODE CONTROL INPUT FUNCTION TABLE

Input	Condition
MODE	Q0:Q6, nQ0:nQ6
0	Default Mode
1	Frequency Margining Mode

ABSOLUTE MAXIMUM RATINGS

Supply Voltage, V_{CC}	4.6V
Inputs, V_I	-0.5V to $V_{CC} + 0.5V$
Outputs, I_O	
Continuous Current	50mA
Surge Current	100mA
Package Thermal Impedance, θ_{JA}	65.7°C/W (0 mps)
Storage Temperature, T_{STG}	-65°C to 150°C

NOTE: Stresses beyond those listed under Absolute Maximum Ratings may cause permanent damage to the device. These ratings are stress specifications only. Functional operation of product at these conditions or any conditions beyond those listed in the *DC Characteristics* or *AC Characteristics* is not implied. Exposure to absolute maximum rating conditions for extended periods may affect product reliability.

TABLE 5A. POWER SUPPLY DC CHARACTERISTICS, $V_{CC} = V_{CCO} = 3.3V \pm 5\%$, $V_{CCO} = V_{EE} = 0V$, $T_A = 0^\circ C$ TO $70^\circ C$

Symbol	Parameter	Test Conditions	Minimum	Typical	Maximum	Units
V_{CC}	Core Supply Voltage		3.135	3.3	3.465	V
V_{CCA}	Analog Supply Voltage		$V_{CC} - 0.13$	3.3	V_{CC}	V
V_{CCO}	Output Supply Voltage		3.135	3.3	3.465	V
I_{EE}	Power Supply Current				210	mA
I_{CCA}	Analog Supply Current				13	mA

TABLE 5B. LVCMOS / LVTTTL DC CHARACTERISTICS, $V_{CC} = V_{CCO} = 3.3V \pm 5\%$, $V_{EE} = 0V$, $T_A = 0^\circ C$ TO $70^\circ C$

Symbol	Parameter	Test Conditions	Minimum	Typical	Maximum	Units
V_{IH}	Input High Voltage	$V_{CC} = 3.3V$	2		$V_{CC} + 0.3$	V
V_{IL}	Input Low Voltage	$V_{CC} = 3.3V$	-0.3		0.8	V
I_{IH}	Input High Current	REF_CLK, MARGIN, MODE, nPLL_SEL, MR, nXTAL_SEL	$V_{CC} = V_{IN} = 3.465$		150	μA
		SEL[0:13]	$V_{CC} = V_{IN} = 3.465$		5	μA
I_{IL}	Input Low Current	REF_CLK, MARGIN, MODE, nPLL_SEL, MR, nXTAL_SEL	$V_{CC} = 3.465V$, $V_{IN} = 0V$	-5		μA
		SEL[0:13]	$V_{CC} = 3.465V$, $V_{IN} = 0V$	-150		μA
$\Delta t/\Delta v$	Input Transition Rise/Fall Rate	SEL[0:13], MODE			20	ns/V

TABLE 5C. LVPECL DC CHARACTERISTICS, $V_{CC} = V_{CCO} = 3.3V \pm 5\%$, $V_{EE} = 0V$, $T_A = 0^\circ C$ TO $70^\circ C$

Symbol	Parameter	Test Conditions	Minimum	Typical	Maximum	Units
V_{OH}	Output High Voltage; NOTE 1		$V_{CCO} - 1.4$		$V_{CCO} - 0.9$	V
V_{OL}	Output Low Voltage; NOTE 1		$V_{CCO} - 2.0$		$V_{CCO} - 1.7$	V
V_{SWING}	Peak-to-Peak Output Voltage Swing		0.6		1.0	V

NOTE 1: Outputs terminated with 50Ω to $V_{CCO} - 2V$.

TABLE 6. CRYSTAL CHARACTERISTICS

Parameter	Test Conditions	Minimum	Typical	Maximum	Units
Mode of Oscillation		Fundamental			
Frequency		12.4	14	15	MHz
Equivalent Series Resistance (ESR)				40	Ω
Shunt Capacitance				7	pF
Drive Level				300	μW

NOTE: Characterized using an 18pF parallel resonant crystal.

TABLE 7. AC CHARACTERISTICS, $V_{CC} = V_{CCO} = 3.3V \pm 5\%$, $V_{EE} = 0V$, $T_A = 0^\circ C$ TO $70^\circ C$

Symbol	Parameter	Test Conditions	Minimum	Typical	Maximum	Units
f_{OUT}	Output Frequency	$N = \div 2$	310	350	375	MHz
		$N = \div 4$	155	175	187.5	MHz
		$N = \div 8$	77.5	87.5	93.75	MHz
f_{IN}	Input Frequency	REF_CLK	12.4	14	15	MHz
$f_{jit}(\emptyset)$	RMS Phase Jitter, Random; NOTE 1	Mode = LOW 350MHz, (12kHz - 20MHz)		1.54		ps
		Mode = LOW 175MHz, (12kHz - 20MHz)		1.48		ps
		Mode = LOW 87.5MHz, (12kHz - 20MHz)		1.61		ps
t_R / t_F	Output Rise/Fall Time	20% to 80%	300		600	ps
odc	Output Duty Cycle	Output Divider = $\div 2$	42		58	%
		Output Divider = $\neq 2$	46		64	%

NOTE 1: Characterized using a 14MHz crystal.

TYPICAL PHASE NOISE AT 175MHz

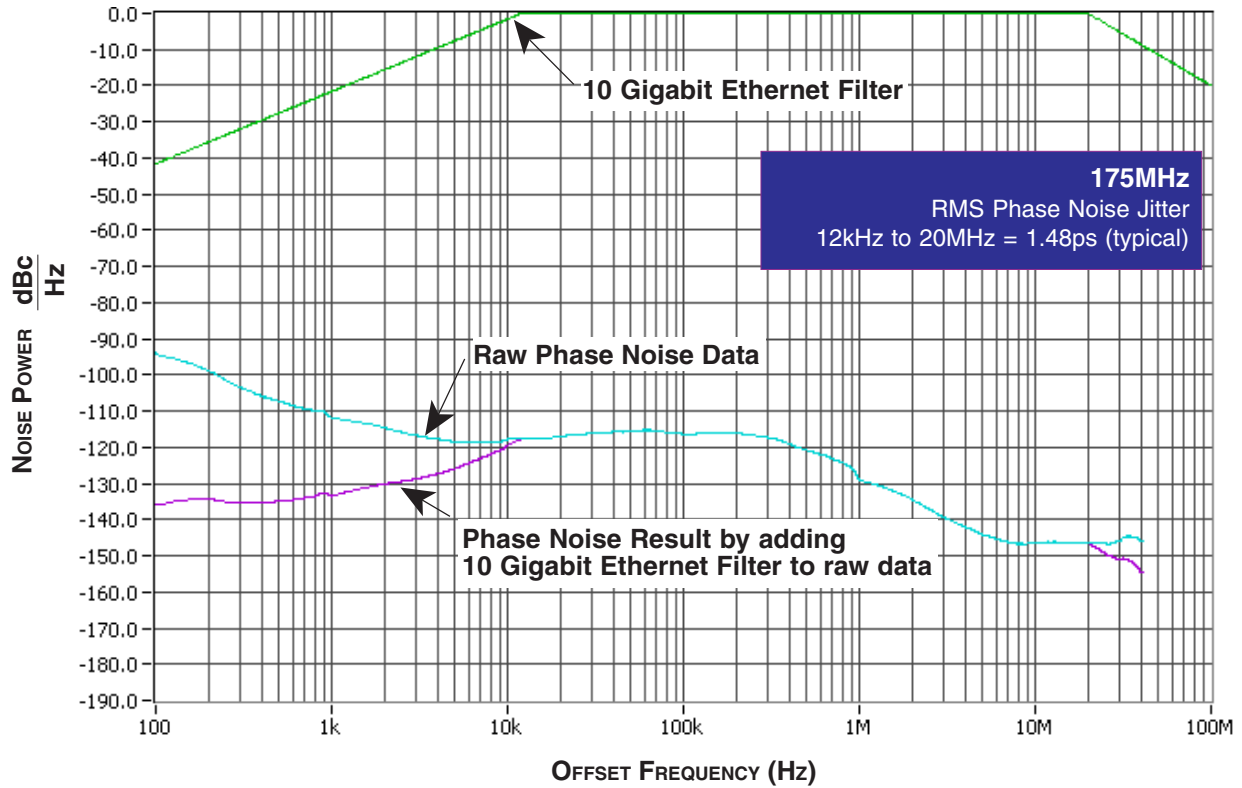

TYPICAL PHASE NOISE AT 350MHz

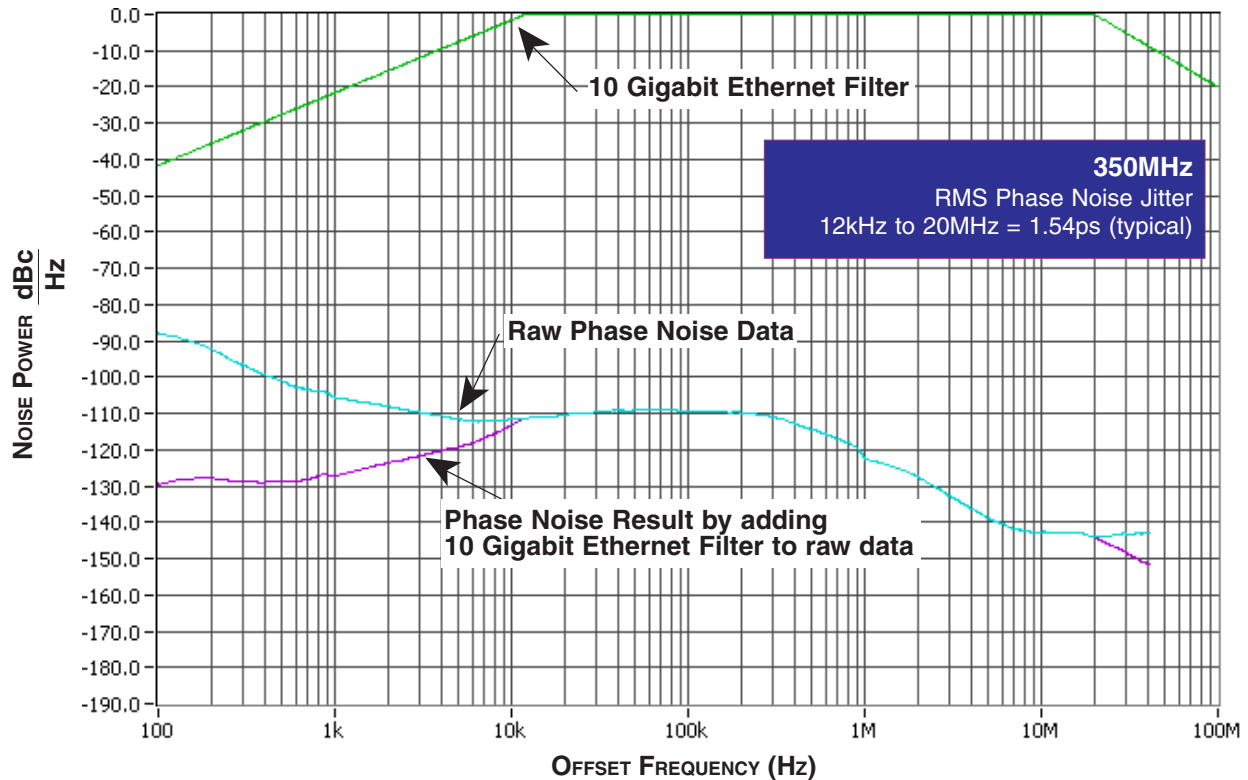

PARAMETER MEASUREMENT INFORMATION

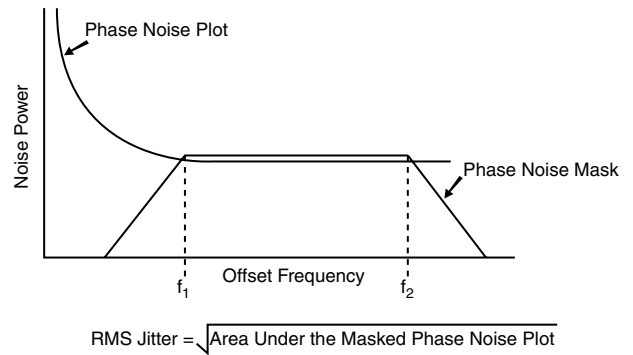
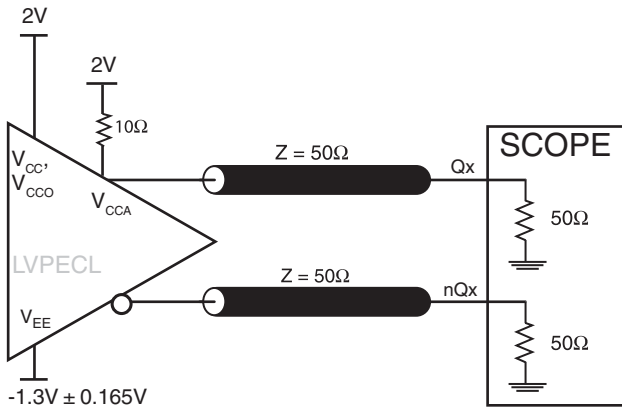

3.3V CORE/3.3V OUTPUT LOAD AC TEST CIRCUIT

RMS PHASE JITTER

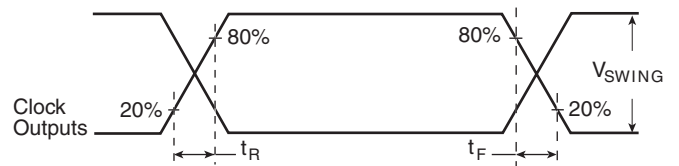
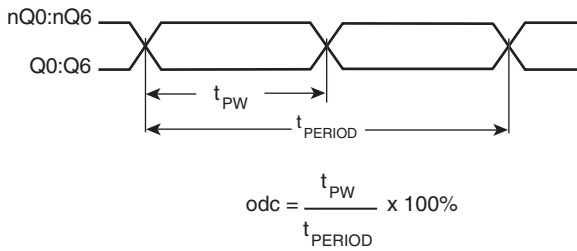

OUTPUT DUTY CYCLE/PULSE WIDTH/PERIOD

OUTPUT RISE/FALL TIME

APPLICATION INFORMATION

POWER SUPPLY FILTERING TECHNIQUES

As in any high speed analog circuitry, the power supply pins are vulnerable to random noise. To achieve optimum jitter performance, power supply isolation is required. The ICS843207-350 provides separate power supplies to isolate any high switching noise from the outputs to the internal PLL. V_{CC} , V_{CCA} and V_{CCO} should be individually connected to the power supply plane through vias, and $0.01\mu\text{F}$ bypass capacitors should be used for each pin. *Figure 1* illustrates this for a generic V_{CC} pin and also shows that V_{CCA} requires that an additional 10Ω resistor along with a $10\mu\text{F}$ bypass capacitor be connected to the V_{CCA} pin.

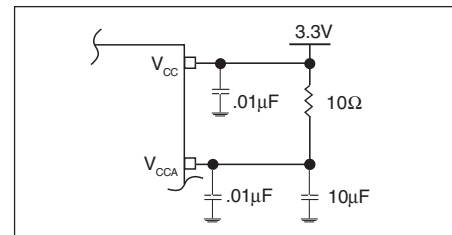

FIGURE 1. POWER SUPPLY FILTERING

CRYSTAL INPUT INTERFACE

The ICS843207-350 has been characterized with 18pF parallel resonant crystals. The capacitor values shown in

Figure 2 below were determined using a 14MHz , 18pF parallel resonant crystal and were chosen to minimize the ppm error.

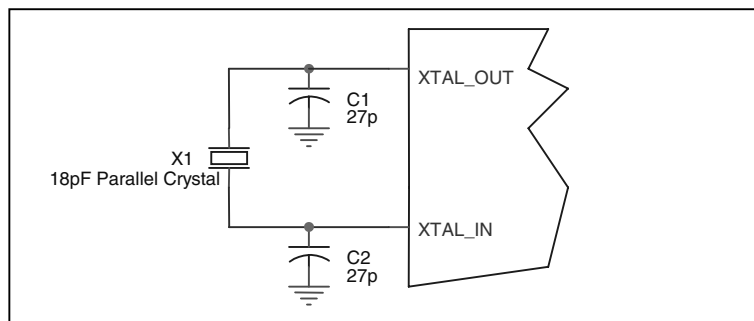

FIGURE 2. CRYSTAL INPUT INTERFACE

LVCMOS TO XTAL INTERFACE

The XTAL_IN input can accept a single-ended LVCMOS signal through an AC couple capacitor. A general interface diagram is shown in *Figure 3*. The XTAL_OUT pin can be left floating. The input edge rate can be as slow as 10ns. For LVCMOS inputs, it is recommended that the amplitude be reduced from full swing to half swing in order to prevent signal interference with the power rail and to reduce noise. This configuration requires that the output

impedance of the driver (R_o) plus the series resistance (R_s) equals the transmission line impedance. In addition, matched termination at the crystal input will attenuate the signal in half. This can be done in one of two ways. First, R1 and R2 in parallel should equal the transmission line impedance. For most 50Ω applications, R1 and R2 can be 100Ω. This can also be accomplished by removing R1 and making R2 50Ω.

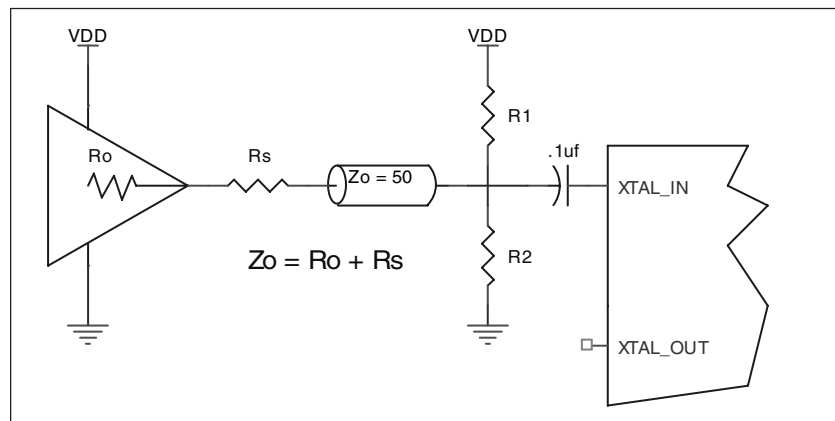

FIGURE 3. GENERAL DIAGRAM FOR LVCMOS DRIVER TO XTAL INPUT INTERFACE

RECOMMENDATIONS FOR UNUSED INPUT AND OUTPUT PINS

INPUTS:

CRYSTAL INPUTS

For applications not requiring the use of the crystal oscillator input, both XTAL_IN and XTAL_OUT can be left floating. Though not required, but for additional protection, a 1kΩ resistor can be tied from XTAL_IN to ground.

REF_CLK INPUT

For applications not requiring the use of the reference clock, it can be left floating. Though not required, but for additional protection, a 1kΩ resistor can be tied from the REF_CLK to ground.

LVCMOS CONTROL PINS

All control pins have internal pull-ups or pull-downs; additional resistance is not required but can be added for additional protection. A 1kΩ resistor can be used.

OUTPUTS:

LVPECL OUTPUTS

All unused LVPECL outputs can be left floating. We recommend that there is no trace attached. Both sides of the differential output pair should either be left floating or terminated.

TERMINATION FOR 3.3V LVPECL OUTPUT

The clock layout topology shown below is a typical termination for LVPECL outputs. The two different layouts mentioned are recommended only as guidelines.

FOUT and nFOUT are low impedance follower outputs that generate ECL/LVPECL compatible outputs. Therefore, terminating resistors (DC current path to ground) or current sources must be used for functionality. These outputs are

designed to drive 50Ω transmission lines. Matched impedance techniques should be used to maximize operating frequency and minimize signal distortion. *Figures 4A and 4B* show two different layouts which are recommended only as guidelines. Other suitable clock layouts may exist and it would be recommended that the board designers simulate to guarantee compatibility across all printed circuit and clock component process variations.

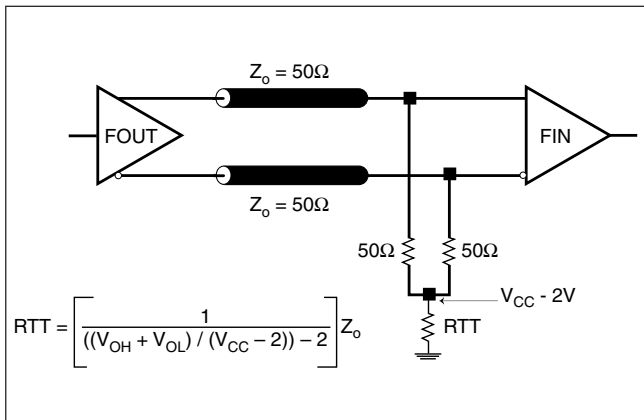

FIGURE 4A. LVPECL OUTPUT TERMINATION

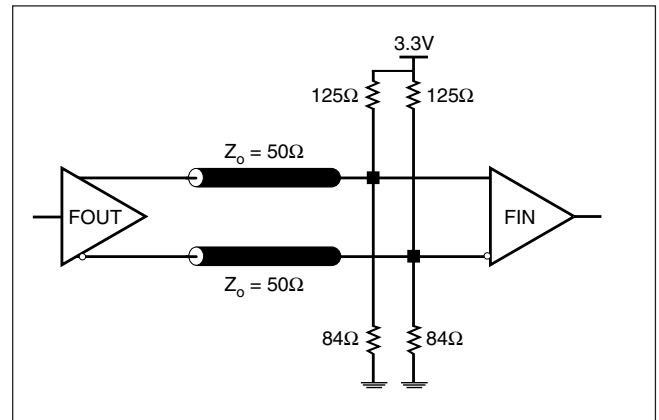

FIGURE 4B. LVPECL OUTPUT TERMINATION

POWER CONSIDERATIONS

This section provides information on power dissipation and junction temperature for the ICS843207-350. Equations and example calculations are also provided.

1. Power Dissipation.

The total power dissipation for the ICS843207-350 is the sum of the core power plus the power dissipated in the load(s). The following is the power dissipation for $V_{CC} = 3.3V + 5\% = 3.465V$, which gives worst case results.

NOTE: Please refer to Section 3 for details on calculating power dissipated in the load.

- Power (core)_{MAX} = $V_{CC_MAX} * I_{EE_MAX} = 3.465V * 210mA = 727.65mW$
- Power (outputs)_{MAX} = **30mW/Loaded Output pair**
If all outputs are loaded, the total power is $7 * 30mW = 210mW$

$$\text{Total Power}_{_MAX} (3.63V, \text{ with all outputs switching}) = 727.65mW + 210mW = 937.65mW$$

2. Junction Temperature.

Junction temperature, T_j , is the temperature at the junction of the bond wire and bond pad and directly affects the reliability of the device. The maximum recommended junction temperature for HiPerClockS™ devices is 125°C.

The equation for T_j is as follows: $T_j = \theta_{JA} * Pd_total + T_A$

T_j = Junction Temperature

θ_{JA} = Junction-to-Ambient Thermal Resistance

Pd_total = Total Device Power Dissipation (example calculation is in section 1 above)

T_A = Ambient Temperature

In order to calculate junction temperature, the appropriate junction-to-ambient thermal resistance θ_{JA} must be used. Assuming air flow at 1 meter per second and a multi-layer board, the appropriate value is 55.9°C/W per Table 8 below.

Therefore, T_j for an ambient temperature of 70°C with all outputs switching is:

$$70^\circ\text{C} + 0.938\text{W} * 55.9^\circ\text{C}/\text{W} = 122.4^\circ\text{C}. \text{ This is below the limit of } 125^\circ\text{C}.$$

This calculation is only an example. T_j will obviously vary depending on the number of loaded outputs, supply voltage, air flow, and the type of board (single layer or multi-layer).

TABLE 8. THERMAL RESISTANCE θ_{JA} FOR 48-PIN LQFP, FORCED CONVECTION

θ_{JA} by Velocity (Meters per Second)			
	0	1	2.5
Multi-Layer PCB, JEDEC Standard Test Boards	65.7°C/W	55.9°C/W	52.4°C/W

3. Calculations and Equations.

The purpose of this section is to derive the power dissipated into the load.

LVPECL output driver circuit and termination are shown in *Figure 5*.

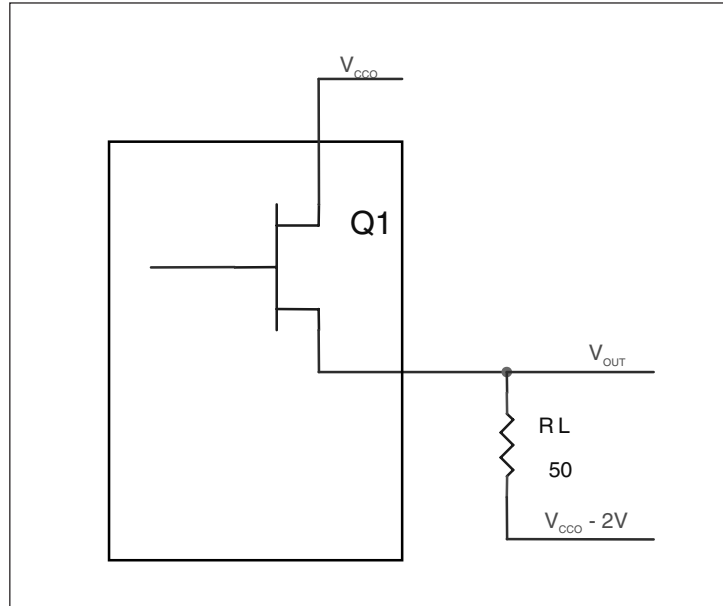

FIGURE 5. LVPECL DRIVER CIRCUIT AND TERMINATION

To calculate worst case power dissipation into the load, use the following equations which assume a 50Ω load, and a termination voltage of $V_{CCO} - 2V$.

- For logic high, $V_{OUT} = V_{OH_MAX} = V_{CCO_MAX} - 0.9V$

$$(V_{CCO_MAX} - V_{OH_MAX}) = 0.9V$$

- For logic low, $V_{OUT} = V_{OL_MAX} = V_{CCO_MAX} - 1.7V$

$$(V_{CCO_MAX} - V_{OL_MAX}) = 1.7V$$

Pd_H is power dissipation when the output drives high.

Pd_L is the power dissipation when the output drives low.

$$Pd_H = [(V_{OH_MAX} - (V_{CCO_MAX} - 2V))/R_L] * (V_{CCO_MAX} - V_{OH_MAX}) = [(2V - (V_{CCO_MAX} - V_{OH_MAX}))/R_L] * (V_{CCO_MAX} - V_{OH_MAX}) = [(2V - 0.9V)/50\Omega] * 0.9V = \mathbf{19.8mW}$$

$$Pd_L = [(V_{OL_MAX} - (V_{CCO_MAX} - 2V))/R_L] * (V_{CCO_MAX} - V_{OL_MAX}) = [(2V - (V_{CCO_MAX} - V_{OL_MAX}))/R_L] * (V_{CCO_MAX} - V_{OL_MAX}) = [(2V - 1.7V)/50\Omega] * 1.7V = \mathbf{10.2mW}$$

Total Power Dissipation per output pair = $Pd_H + Pd_L = \mathbf{30mW}$

RELIABILITY INFORMATION

TABLE 9. θ_{JA} VS. AIR FLOW TABLE FOR 48 LEAD LQFP

θ_{JA} by Velocity (Meters per Second)			
	0	1	2.5
Multi-Layer PCB, JEDEC Standard Test Boards	65.7°C/W	55.9°C/W	52.4°C/W

TRANSISTOR COUNT

The transistor count for ICS843207-350 is: 4380

PACKAGE OUTLINE - Y SUFFIX FOR 48 LEAD LQFP

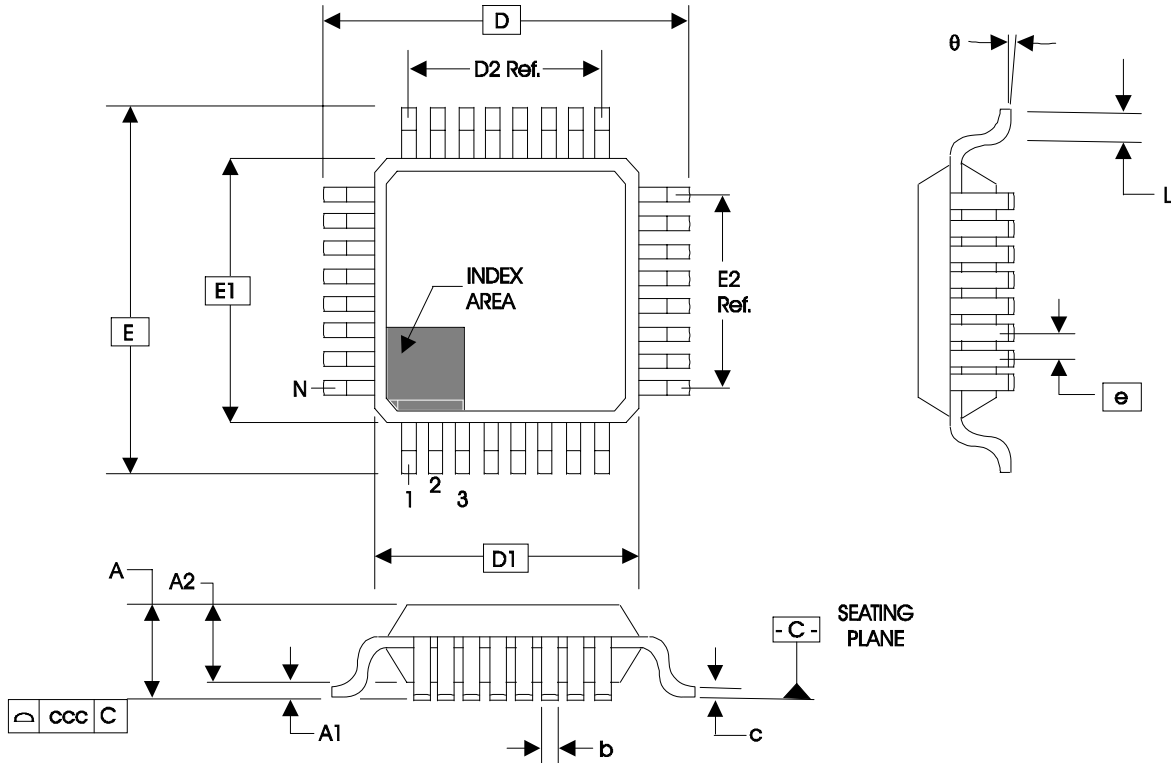

TABLE 10. PACKAGE DIMENSIONS

JEDEC VARIATION ALL DIMENSIONS IN MILLIMETERS			
SYMBOL	BBC		
	MINIMUM	NOMINAL	MAXIMUM
N	48		
A	--	--	1.60
A1	0.05	--	0.15
A2	1.35	1.40	1.45
b	0.17	0.22	0.27
c	0.09	--	0.20
D	9.00 BASIC		
D1	7.00 BASIC		
D2	5.50 Ref.		
E	9.00 BASIC		
E1	7.00 BASIC		
E2	5.50 Ref.		
e	0.50 BASIC		
L	0.45	0.60	0.75
θ	0°	--	7°
ccc	--	--	0.08

Reference Document: JEDEC Publication 95, MS-026

TABLE 11. ORDERING INFORMATION

Part/Order Number	Marking	Package	Shipping Packaging	Temperature
843207CY-350	43207C350	48 Lead LQFP	tray	0°C to 70°C
843207CY-350T	43207C350	48 Lead LQFP	1000 tape & reel	0°C to 70°C
843207CY-350LF	3207C350L	48 Lead "Lead-Free" LQFP	tray	0°C to 70°C
843207CY-350LFT	3207C350L	48 Lead "Lead-Free" LQFP	1000 tape & reel	0°C to 70°C

NOTE: Parts that are ordered with an "LF" suffix to the part number are the Pb-Free configuration and are RoHS compliant.

ICS843207-350

FEMTOCLOCKS™ CRYSTAL-TO-LVPECL 350MHZ FREQUENCY MARGINING SYNTHESIZER

PRELIMINARY

Innovate with IDT and accelerate your future networks. Contact:

www.IDT.com

For Sales

800-345-7015
408-284-8200
Fax: 408-284-2775

For Tech Support

netcom@idt.com
480-763-2056

Corporate Headquarters

Integrated Device Technology, Inc.
6024 Silver Creek Valley Road
San Jose, CA 95138
United States
800 345 7015
+408 284 8200 (outside U.S.)

Asia Pacific and Japan

Integrated Device Technology
Singapore (1997) Pte. Ltd.
Reg. No. 199707558G
435 Orchard Road
#20-03 Wisma Atria
Singapore 238877
+65 6 887 5505

Europe

IDT Europe, Limited
321 Kingston Road
Leatherhead, Surrey
KT22 7TU
England
+44 (0) 1372 363 339
Fax: +44 (0) 1372 378851

