

## Single Output UNS Series

### Non-Isolated, 3.3V and 5V 3 Amp, DC/DC Converters

#### Features

- Low cost
- SIP or DIP packaging
- 3.3V (10W) or 5V (15W) outputs
- Wide range inputs:  
4.75-13.6V for 3.3V models  
6-16.5V for 5V models
- High efficiencies, typically 90-92%
- Low output noise, 50mVp-p
- Remote on/off control
- 100µA "standby" input current
- Output current limiting
- EMC compliant
- Highly reliable, 100% SMT construction
- Conformally coated for harsh environments

Low cost, high efficiency, wide input voltage range and low output noise define DATEL's new UNS Series of non-isolated, step-down, switching DC/DC converters. The 3.3V- and 5V-output devices are, respectively, 90% and 92% efficient. All models are fully line and load regulated and maintain specified accuracy over the impressively wide input voltage ranges of 4.75 to 13.6 Volts for 3.3V outputs and 6 to 16.5 Volts for 5V outputs. Output ripple and noise are typically 50mVp-p.

UNS devices are fabricated using proven SMT-on-pcb construction techniques. The 3.3V and 5V devices are both available in either lightweight SIP (2" x 0.4" x 0.8") or DIP (2" x 0.8" x 0.4", 600 mil spacing between rows) package configurations. The DIP option is designated by a "D" suffix added to the part number. All models are conformally coated for protection against moisture and dust.

The high efficiency of the UNS Series' fixed-frequency (190kHz) switching design eliminates the need for thermally conductive potting compound. Devices are specified for full-power operation up to ambient temperatures of +50°C. With derating, they operate up to +70°C. Calculated MTBF (MIL-HDBK-217F) is more than 1.6 million hours.

These simple-to-use power converters have no minimum load requirements. They draw 1mA when unloaded and a mere 100µA in the standby mode (On/Off Control turned off). 3.3V models have an output voltage adjustment range of 2.7 to 3.3 Volts. 5V models are adjustable down to 3.0V.

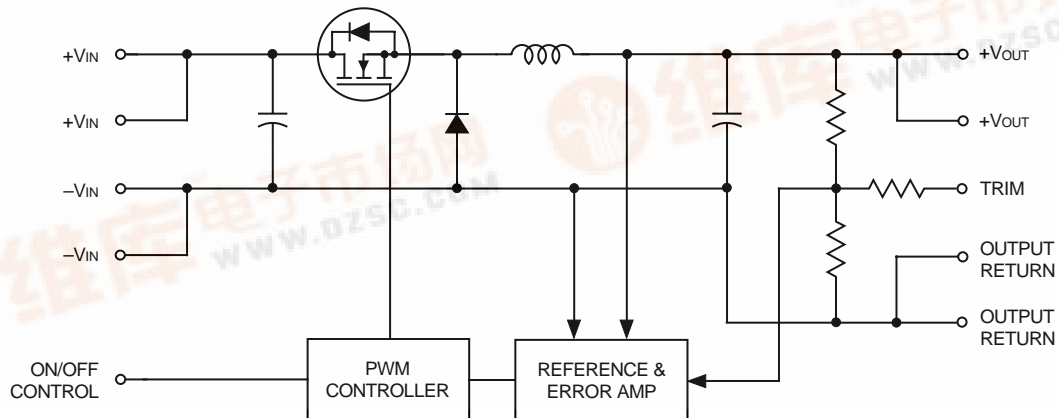

Figure 1. Simplified Schematic



Performance Specifications and Ordering Guide <sup>①</sup>

Model <sup>②</sup>	Output				Input			Efficiency		Package (Case, Pinout)		
	V <sub>OUT</sub> (Volts)	I <sub>OUT</sub> (Amps)	R/N (mVp-p) <sup>③</sup>		Regulation (Max.) <sup>④</sup>		V <sub>IN</sub> Nom. (Volts)	Range (Volts)	I <sub>IN</sub> <sup>⑤</sup> (mA)		Min.	Typ.
			Typ.	Max.	Line	Load						
UNS-3.3/3-D5	3.3	3	50	100	±1.0%	±3.0%	7.5	4.75-13.6	1/1400	--	90%	B1, P18
UNS-3.3/3-D5D	3.3	3	50	100	±1.0%	±3.0%	7.5	4.75-13.6	1/1400	--	90%	B2, P18
UNS-5/3-D12	5	3	50	100	±1.0%	±3.0%	12	6-16.5	1/1330	--	92%	B1, P18
UNS-5/3-D12D	5	3	50	100	±1.0%	±3.0%	12	6-16.5	1/1330	--	92%	B2, P18

- ① Typical at T<sub>A</sub> = +25°C under nominal line voltage and full-load conditions, unless otherwise noted.
- ② "D" suffix indicates DIP package.
- ③ Ripple/Noise (R/N) measured over a 20MHz bandwidth with a 100µF external input capacitor and a 220µF external output capacitor. Additional output capacitors will lower R/N. See Technical Notes.
- ④ Listed output regulation specifications describe the total change in output voltage as the input (line) voltage or output (load) current is varied over its full specified range. Typically, line regulation is better than ±0.5% and load regulation is better than ±1.0%. Load regulation applies for 0 to 100% load conditions.
- ⑤ Nominal line voltage, no-load/full-load conditions.

PART NUMBER STRUCTURE

**UNS - 3.3 / 3 - D5 D**

Output Configuration:  
U = Unipolar

Non-Isolated  
SIP packaging

Nominal Output Voltage:  
3.3 or 5 Volts

Input Voltage Range:  
D5 = 4.75-13.6 Volts (7.5V nominal)  
D12 = 6-16.5 Volts (12V nominal)

Maximum Output Current  
in Amps

Add "D" suffix for optional  
DIP package configuration

TEMPERATURE DERATING

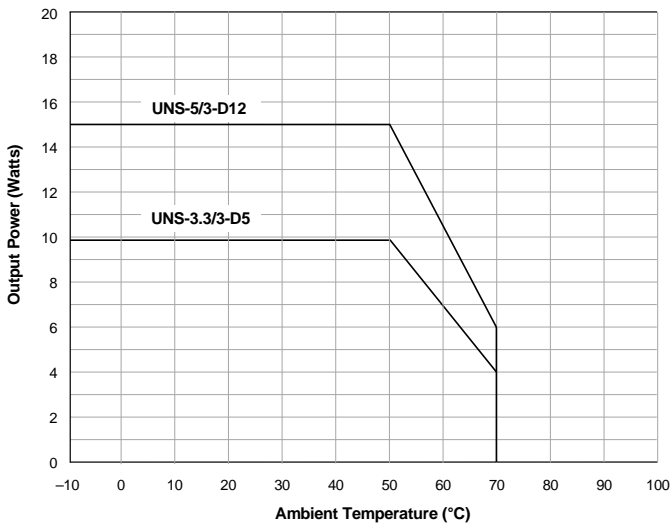

Note: Derating curves apply to both SIP and DIP package configurations

MECHANICAL SPECIFICATIONS

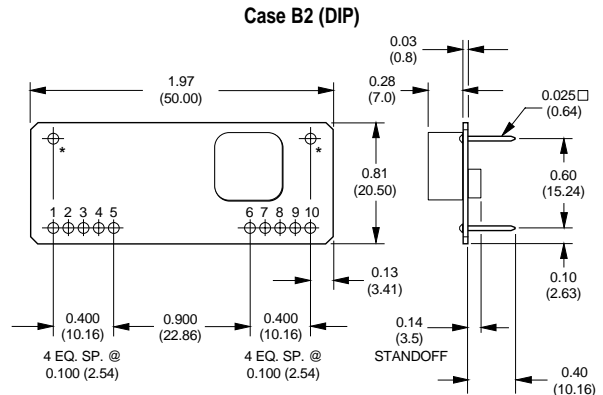
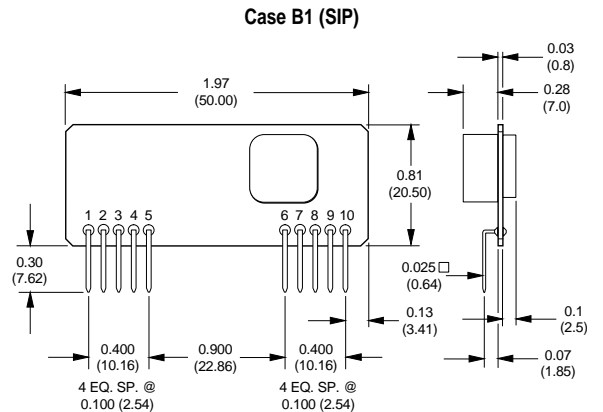

\* NO CONNECTION. FOR MECHANICAL STABILITY ONLY.

I/O Connections			
Pin	Function P18	Pin	Function P18
1	+Input	6	Trim
2	+Input	7	Output Rtn.
3	-Input	8	Output Rtn.
4	-Input	9	+Output
5	On/Off Control	10	+Output

Typical @ T<sub>A</sub> = +25°C under nominal line voltage and full-load conditions, unless noted. ①

Input	
<b>Input Voltage Range:</b>	
"D5" and "D5D" Models	4.75-13.6 Volts (7.5V nominal)
"D12" and "D12D" Models	6-16.5 Volts (12V nominal)
<b>Input Current</b>	See Ordering Guide
<b>Input Filter Type</b>	Capacitive
<b>Overvoltage Protection</b>	None
<b>Reverse-Polarity Protection</b>	None
<b>On/Off Control (Pin 5) ②</b>	TTL high (or open) = on, low = off
Output	
<b>Vout Accuracy</b>	±5%, maximum
<b>Temperature Coefficient</b>	±0.01% per °C
<b>Ripple/Noise (20MHz bandwidth) ③</b>	See Ordering Guide
<b>Line/Load Regulation ④</b>	See Ordering Guide
<b>Efficiency</b>	See Ordering Guide
<b>Current Limiting ⑤</b>	Auto-recovery
Dynamic Characteristics	
<b>Transient Response (50% load step)</b>	200µsec max. to ±2% of final value
<b>Switching Frequency</b>	190kHz
Environmental	
<b>Operating Temperature:</b>	
Without Derating	-10 to +50°C
With Derating	to +70°C (See Derating Curve)
<b>Storage Temperature</b>	-25 to +85°C
Physical	
<b>Dimensions:</b> SIP Models	2 x 0.41 x 0.8" (50 x 10.3 x 21mm)
DIP Models ⑥	2 x 0.8 x 0.44" (50 x 21 x 11.3mm)
<b>Shielding</b>	None
<b>Case Connection</b>	None
<b>Pin Material</b>	Gold-plated phosphor bronze
<b>Weight</b>	0.35 ounces (10 grams)

① UNS Series devices require external input/output capacitors to achieve rated performance. Listed specifications assume C<sub>IN</sub> = 100µF and C<sub>OUT</sub> = 220µF.

② See Technical Notes.

③ Output Ripple/Noise can be reduced with external capacitors. See Technical Notes.

④ UNS Series converters have no minimum-load requirements.

⑤ Current limiting initiates at approximately 5% above rated load.

⑥ DIP models have a standoff which makes their total above-board height 0.44 inches.

Absolute Maximum Ratings	
<b>Input Voltage:</b>	
"D5" Models	15 Volts
"D12" Models	18 Volts
<b>Input Reverse-Polarity Protection</b>	None. See Technical Notes.
<b>Output Overvoltage Protection</b>	None
<b>Output Current</b>	Current limited. Devices can withstand an output short circuit for brief durations only.
<b>Storage Temperature</b>	-25 to +85°C
<b>Lead Temperature (soldering, 10 sec.)</b>	+300°C
These are stress ratings. Exposure of devices to any of these conditions may adversely affect long-term reliability. Proper operation under conditions other than those listed in the Performance/Functional Specifications Table is not implied.	

#### TECHNICAL NOTES

##### Input and Output Capacitors

Though UNS Series, non-isolated, DC/DC converters have on-board input and output capacitors (C<sub>IN</sub> = 6.8µF, C<sub>OUT</sub> = 6.8µF), the majority of applications will require the installation of additional external I/O capacitance.

The total input capacitance functions as a true energy-storage element, and its optimal value will vary as a function of line voltage. The selected external input capacitor should have both low ESR and low ESL because, as the power converter's input FET switch cycles on and off, the input capacitance must have the ability to instantaneously supply pulses of relatively high current.

Rather than install a large, expensive, on-board capacitor that addresses all possible input-voltage and output-load conditions, DATEL has chosen to leave out the bulk of the input capacitance so that users may select a cost-effective component appropriate to their own application. We use a low-ESR 100µF external input capacitor during production testing and have found 330µF to be a conservative value that works well in the majority of applications.

In addition to their on-board output capacitor, UNS Series devices require the installation of additional output capacitors to achieve rated ripple/noise specifications. External output capacitors should be low-ESR tantalum or electrolytic types, and they should be located as close to the converters as possible. A minimum of 220µF is required to achieve rated ripple/noise specs. Increased capacitance will lower output noise. There are no limitations on output capacitance; however, we have found minimal noise improvements beyond 4700µF.

**Output Trimming**

5V devices can be trimmed down to 3.0V, and 3.3V devices can be trimmed down to 2.7V using a single external trimpot or fixed resistor. The trimpot should be connected between +Vout (pins 9 and 10) and Trim (pin 6) as shown in the figure below. The trimpot can be used to determine the value of a single fixed resistor which can then be connected between pins 9 and 10 and 6. Fixed resistors should be metal-film types with relatively low absolute TCR's to ensure stability.

In order to maximize their efficiency, UNS devices employ high-value resistors in their voltage feedback loop. Consequently, the external trimpots must also be high-resistance devices (1-2 megohms). If the trimpots are accidentally turned to their 0Ω stops, it will not damage the converters; however, the output voltage will be pulled down to an unstable level. Use care not to trim the output voltage below the levels indicated in the accompanying table.

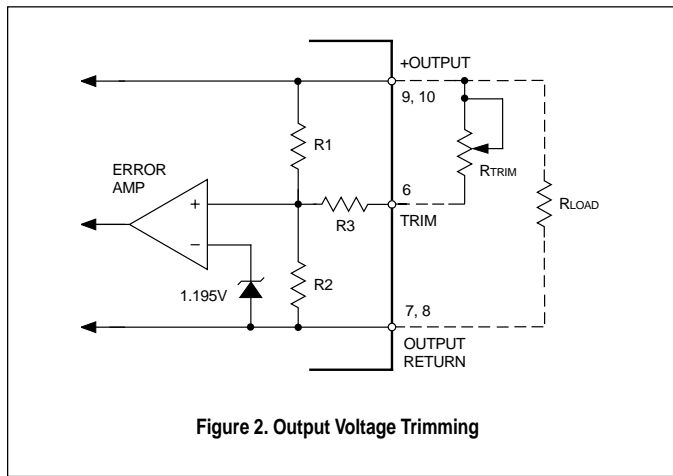

Figure 2. Output Voltage Trimming

Product	UNS-3.3/3	UNS-5/3
Output Voltage Adjustment Range	2.7 to 3.3V	3.0 to 5.0V
R1	68.68kΩ	124.7kΩ
R2	38kΩ	39kΩ
R3	10kΩ	10kΩ
R <sub>TRIM</sub>	≥160kΩ	≥100kΩ

Table 1. Output Voltage Trim Values

**The On/Off Control Pin**

For normal operation, pin 5 should be left open. This pin has an internal 250kΩ pull-up resistor to +5V (or to +V<sub>IN</sub> if +V<sub>IN</sub> < 5V). For dynamic control of the converters' on/off functionality, a TTL logic high (+2.4V minimum, +5V maximum or +V<sub>IN</sub> maximum if +V<sub>IN</sub> < 5V, 100μA max.) applied to pin 5 enables the converter, and a quasi-TTL logic low (0 to +0.5V, 100μA max.) disables the converter. Control voltages should be referenced to pins 3 and 4 (-Input). For best results, use a mechanical relay or open-collector logic.

When the converter is turned off, its input "standby" current will be approximately 100μA. Applying a voltage that is greater than V<sub>IN</sub> to the On/Off Control pin, or applying any voltage to this pin when no input power is applied to the converter, may cause permanent damage to the converter.

**TYPICAL PERFORMANCE CURVES**

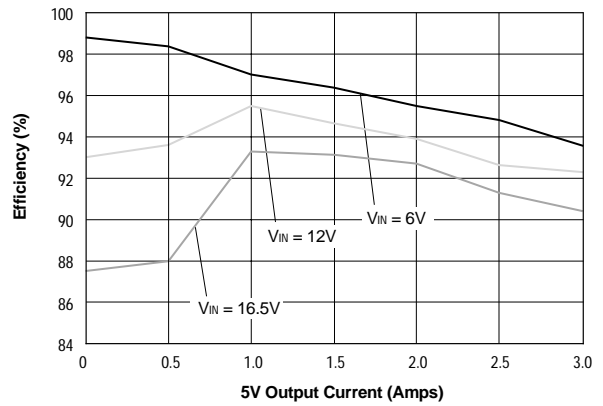

Efficiency vs. Output Current and Input Voltage (Model UNS-5/3)

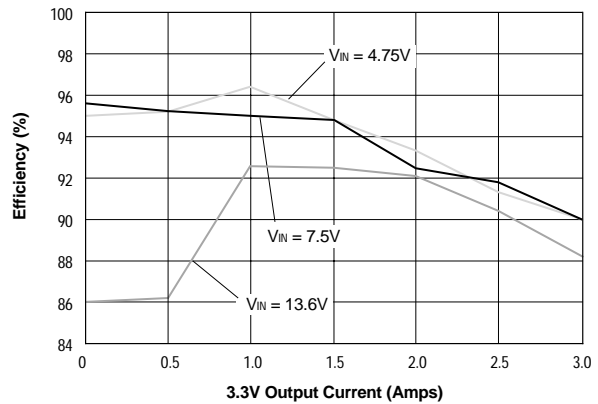

Efficiency vs. Output Current and Input Voltage (Model UNS-3.3/3)

## NON-ISOLATED DC/DC CONVERTER SELECTION GUIDE

### 2.5V SINGLE OUTPUT, NON-ISOLATED

Output Current (Amps, Max.)	Input Voltage, Nominal (Range) (Volts)	Package ①		Regulation		Ripple/Noise ② (mVp-p)	Efficiency (Min.)	DATEL Model Number	Data Sheet @ www.datel.com
		Dimensions (Inches)	Case, Pinout	Line (Max.)	Load (Max.)				
2	5 (4.75-5.5)	1 x 1 x 0.45	C7A, P9	±0.25%	±0.5%	30	83%	UNR-2.5/2-D5	UNR, 5W
8	5 (4.75-5.5)	2 x 1 x 0.39	C5A, P9	±0.1%	±0.5%	40	86%	UNR-2.5/8-D5	UNR, 20/25W
	12 (10.4-13.6)	2 x 1 x 0.48	C5C, P9	±0.1%	±0.6%	40	85%	UNR-2.5/8-D12	UNR, 20/25W
10	5 (4.75-5.5)	2 x 1 x 0.39	C5A, P9	±0.1%	±0.5%	40	85%	UNR-2.5/10-D5	UNR, 20/25W
	12 (10.4-13.6)	2 x 1 x 0.48	C5C, P9	±0.1%	±0.6%	40	83%	UNR-2.5/10-D12	UNR, 20/25W
12	5 (4.75-5.5)	2 x 1 x 0.44	C5B, P9	±0.1%	±0.5%	40	84%	UNR-2.5/12-D5	UNR, 30W
20	5 (4.5-5.5)	2 x 2 x 0.49	C21, P26	±0.1%	±1.0%	60	85%	UNR-2.5/20-D5 ③	Contact DATEL

### 3.3V SINGLE OUTPUT, NON-ISOLATED

3	5 (4.75-5.5)	1 x 1 x 0.45	C7A, P9	±0.4%	±0.5%	30	86%	UNR-3.3/3-D5	UNR, 10W
	7.5 (4.75-13.6)	2 x 0.4 x 0.8 ④	B1, P18	±1.0%	±3.0%	50	90% ⑥	UNS-3.3/3-D5	UNS, 10/15W
	7.5 (4.75-13.6)	2 x 0.8 x 0.4 ⑤	B2, P18	±1.0%	±3.0%	50	90% ⑥	UNS-3.3/3-D5D	UNS, 10/15W
	12 (10.4-13.6)	1 x 1 x 0.45	C7A, P9	±0.25%	±0.5%	100	87%	UNR-3.3/3-D12	UNR, 10W
8	5 (4.75-5.5)	2 x 1 x 0.39	C5A, P9	±0.1%	±0.5%	40	88%	UNR-3.3/8-D5	UNR, 26/33W
	5 (4.75-5.5)	2 x 1 x 0.39	C16A, P23	±0.1%	±0.5%	40	88%	UNR-3.3/8-D5T ③ ⑧	Contact DATEL
	5 (4.75-5.5)	2 x 0.4 x 0.53 ⑨	B3, P27	±0.1%	±0.5%	40	88%	USN-3.3/8-D5 ③	Contact DATEL
	12 (10.4-13.6)	2 x 1 x 0.48	C5C, P9	±0.1%	±0.6%	60	86%	UNR-3.3/8-D12	UNR, 26/33W
10	12 (10.4-13.6)	2 x 1 x 0.48	C16C, P23	±0.1%	±0.6%	60	86%	UNR-3.3/8-D12T ③ ⑧	Contact DATEL
	5 (4.75-5.5)	2 x 1 x 0.39	C5A, P9	±0.1%	±0.5%	40	86%	UNR-3.3/10-D5	UNR, 26/33W
	5 (4.75-5.5)	2 x 1 x 0.39	C16A, P23	±0.1%	±0.5%	40	86%	UNR-3.3/10-D5T ③ ⑧	Contact DATEL
	5 (4.75-5.5)	2 x 0.4 x 0.53 ⑨	B3, P27	±0.1%	±0.5%	40	86%	USN-3.3/10-D5 ③	Contact DATEL
12	12 (10.4-13.6)	2 x 1 x 0.48	C5C, P9	±0.1%	±0.6%	60	85%	UNR-3.3/10-D12	UNR, 26/33W
	12 (10.4-13.6)	2 x 1 x 0.48	C16C, P23	±0.1%	±0.6%	60	85%	UNR-3.3/10-D12T ③ ⑧	Contact DATEL
12	5 (4.75-5.5)	2 x 1 x 0.44	C5B, P9	±0.1%	±0.5%	40	87%	UNR-3.3/12-D5	UNR, 40W
20	5 (4.5-5.5)	2 x 2 x 0.49	C21, P26	±0.1%	±1.0%	50	87%	UNR-3.3/20-D5 ③	Contact DATEL

### 5V SINGLE OUTPUT, NON-ISOLATED

3	12 (6-16.5)	2 x 0.4 x 0.8 ④	B1, P18	±1.0%	±3.0%	50	92% ⑥	UNS-5/3-D12	UNS, 10/15W
	12 (6-16.5)	2 x 0.8 x 0.4 ⑤	B2, P18	±1.0%	±3.0%	50	92% ⑥	UNS-5/3-D12D	UNS, 10/15W
5 ⑦	12 (10.4-13.6)	2 x 1 x 0.48	C13, P21	±0.25%	±0.5%	60	87%	UNR-5/5-D12	UNR, 25W

Listed specifications are typical at T<sub>A</sub> = +25°C under nominal line voltage and full-load conditions, unless noted.

① See individual product data sheets for mechanical specifications and pinouts.

② Ripple/Noise is specified over a 20MHz bandwidth.

③ Listed specifications for these products are preliminary.

④ 10-pin SIP package.

⑤ 10-pin DIP package.

⑥ Listed specification is a typical.

⑦ Output voltage is user adjustable from 3.3 to 6V.

⑧ Output voltage is user adjustable from 1.4 to 3.6V.

⑨ Industry-standard, 11-pin SIP package.