



- Steep Roll-off Filter for 915 MHz ISM band
- Complies with Directive 2002/95/EC (RoHS)



SF2049E

**915.00 MHz
SAW Filter**

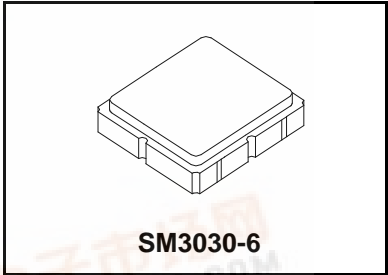

Absolute Maximum Ratings

Rating	Value	Units
Input Power Level	15	dBm
DC Voltage	5	V
Operating Temperature Range	-40 to +85	°C
Storage Temperature Range	-40 to +85	°C

Electrical Characteristics

Characteristic	Sym	Notes	Min	Typ	Max	Units
Center Frequency	F _C			915.00		MHz
Insertion Loss within 902 ~ 928 MHz	IL			2.2	3.5	dB
Amplitude Ripple (p-p) within 902 ~ 928 MHz				0.6	2.0	
VSWR within 902 ~ 928 MHz				1.6	2.3	
Attenuation (Reference level from 0dB)		D.C. ~ 800 MHz	50	63.0		
		800 ~ 880 MHz	40.0	48.0		
		960 ~ 1080 MHz	32.0	39.0		
		1080 ~ 1500 MHz	45.0	65.0		
		1500 ~ 3000 1500 MHz	22.0	28.0		
Source Impedance	Z _S			50		Ω
Load Impedance	Z _L			50		Ω

Case Style	SM3030-6 3.0 x 3.0 mm Nominal Footprint
Lid Symbolization (Y=year, WW=week, S=shift) dot=pin 1 indicator	541, YWWS
Standard Reel Quantity	1000 Pieces/Reel
Reel Size 7 Inch	
Reel Size 13 Inch	3000 Pieces/Reel

Electrical Connections

Connection	Terminals
Port 1	2
Port 2	5
Case Ground	All others

Notes:

1. Unless noted otherwise, all specifications apply over the operating temperature range with filter soldered to the specified demonstration board with impedance matching to 50 Ω and measured with 50 Ω network analyzer.
2. Unless noted otherwise, all frequency specifications are referenced to the nominal center frequency, f_c.
3. Rejection is measured as attenuation below the minimum IL point in the passband. Rejection in final user application is dependent on PCB layout and external impedance matching design. See Application Note No. 42 for details.
4. "LRIP" or "L" after the part number indicates "low rate initial production" and "ENG" or "E" indicates "engineering prototypes."
5. The design, manufacturing process, and specifications of this filter are subject to change.
6. Either Port 1 or Port 2 may be used for either input or output in the design. However, impedances and impedance matching may vary between Port 1 and Port 2, so that the filter must always be installed in one direction per the circuit design.
7. US and international patents may apply.
8. RFM, stylized RFM logo, and RF Monolithics, Inc. are registered trademarks of RF Monolithics, Inc.
9. ©Copyright 1999, RF Monolithics Inc.
10. Electrostatic Sensitive Device. Observe precautions for handling.



915.00 MHz

SAW Filter

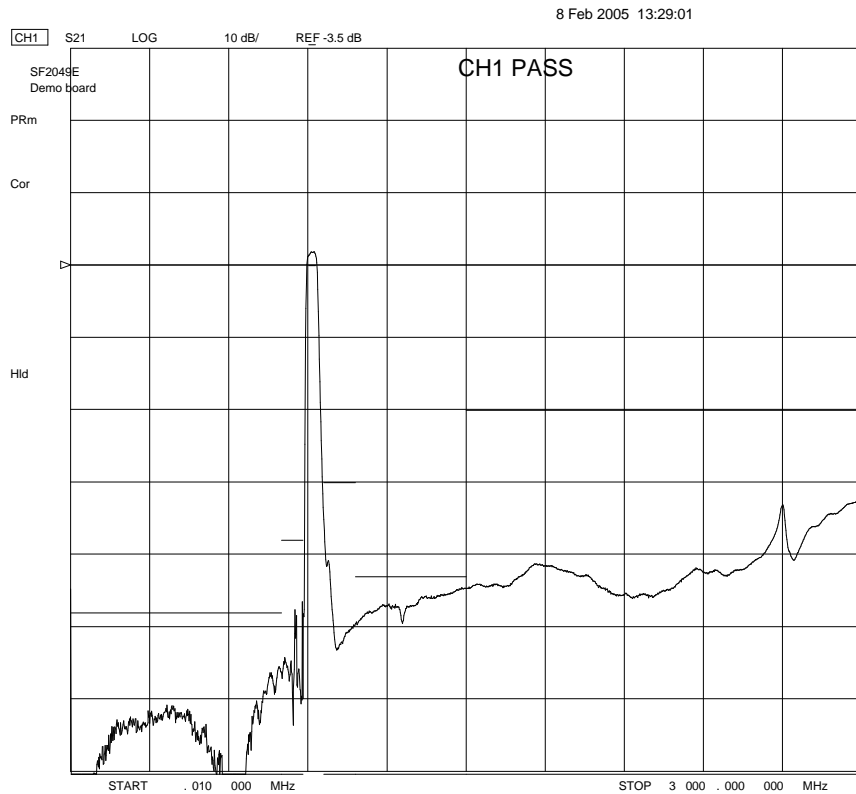
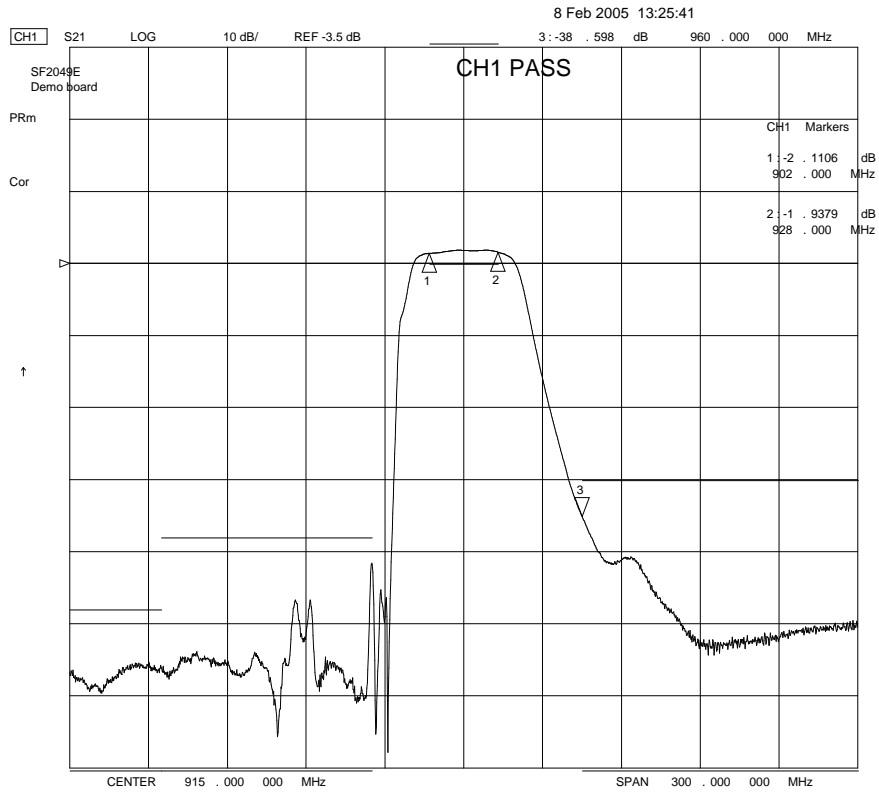

915.00 MHz

SAW Filter

Tape and Reel Specifications

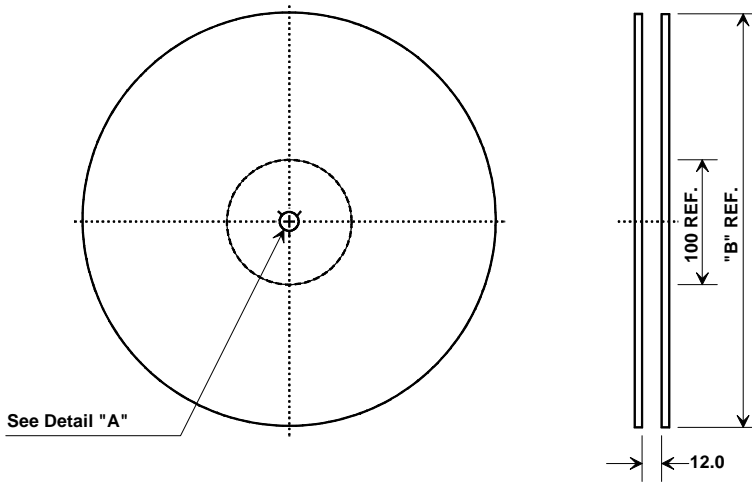

"B "		Quantity Per Reel
Inches	millimeters	
7	178	1000
13	330	3000

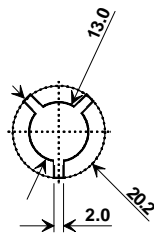

COMPONENT ORIENTATION and DIMENSIONS

Carrier Tape Dimensions	
Ao	3.35 mm
Bo	3.35 mm
Ko	1.40 mm
Pitch	8.0 mm
W	12.0 mm

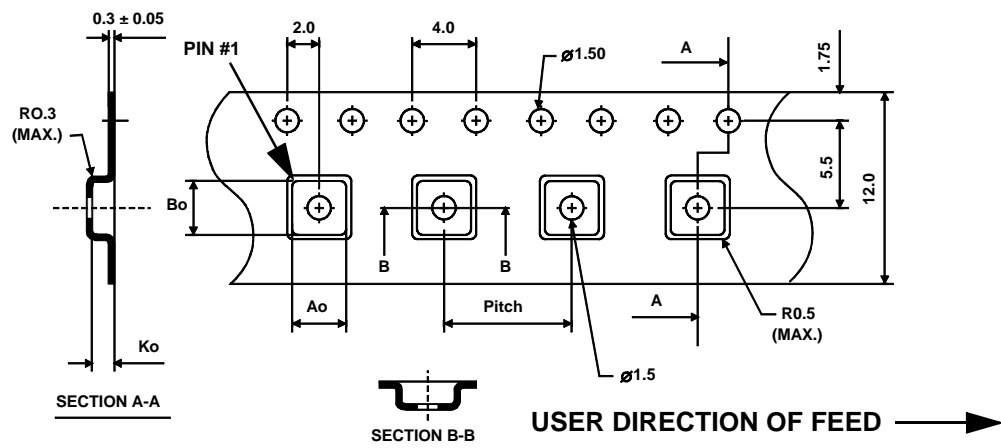

915.00 MHz

SAW Filter

SM3030-6 Case

**6-Terminal Ceramic Surface-Mount Case
3.0 X 3.0 mm Nominal Footprint**

Case Dimensions

Dimension	mm			Inches		
	Min	Nom	Max	Min	Nom	Max
A	2.87	3.0	3.13	0.113	0.118	0.123
B	2.87	3.0	3.13	0.113	0.118	0.123
C	1.12	1.25	1.38	0.044	0.049	0.054
D	0.77	0.9	1.03	0.030	0.035	0.040
E	2.67	2.80	2.93	0.105	0.110	0.115
F	1.47	1.6	1.73	0.058	0.063	0.068
G	0.72	0.85	0.98	0.028	0.033	0.038
H	1.37	1.5	1.63	0.054	0.059	0.064
I	0.47	0.6	0.73	0.019	0.024	0.029
J	1.17	1.3	1.43	0.046	0.051	0.056

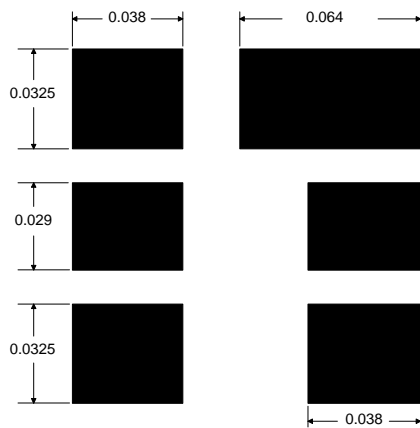

Foot Print Dimensions in Nominal Inches

Electrical Connections

Connection		Terminals
Port 1	Single Ended Input	2
Port 2	Single Ended Output	5
	Ground	All others
Single Ended Operation Only		
Dot indicates Pin 1		

TOP VIEW

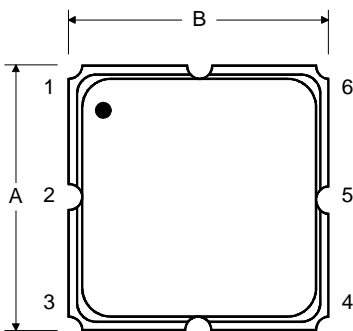

BOTTOM VIEW

