

LED LAMP

TRIANGULAR TYPE



TRIANGULAR TYPE	LENS COLOR				EMITTING COLOR	LUMINOUS INTENSITY IN MCD @10MA			
	Color Diffused (TYP 1)	Color Transparent (TYP 2)	White Diffused (TYP 3)	Water Clear (TYP 4)		TYP			
						1	2	3	4
<p>As sample in P25-44</p>	T1123 T2123 T3123 T3123P T4123 T5123 T7123		T1323 T2323 T3323 T3323P T4323 T5323 T7323		Red GaAsP Yellow Green Pure Green Orange Red GaP Low Current Red	0.6 1.2 1.4 1.2 2.0 1.2 1.6		0.6 1.2 1.4 1.2 2.0 1.2 1.6	
<p>As sample in P25-44</p>	T1133 T2133 T3133 T3133P T4133 T5133 T7133		T1333 T2333 T3333 T3333P T4333 T5333 T7333		Red GaAsP Yellow Green Pure Green Orange Red GaP Low Current Red	1.1 2.1 2.5 2.1 2.6 2.1 2.5		1.1 2.1 2.5 2.1 2.6 2.1 2.5	
	T1114 T2114 T3114 T3114P T4114 T5114 T7114		T1314 T2314 T3314 T3314P T4314 T5314 T7314		Red GaAsP Yellow Green Pure Green Orange Red GaP Low Current Red	0.6 1.2 1.4 1.2 2.0 1.2 1.6		0.6 1.2 1.4 1.2 2.0 1.2 1.6	
	T1122 T2122 T3122 T3122P T4122 T5122 T7122		T1322 T2322 T3322 T3322P T4322 T5322 T7322		Red GaAsP Yellow Green Pure Green Orange Red GaP Low Current Red	0.6 1.2 1.4 1.2 2.0 1.2 1.6		0.6 1.2 1.4 1.2 2.0 1.2 1.6	
	S1137 S2137 S3137 S3137P S4137 S5137 S7137		S1237 S2237 S3237 S3237P S4237 S5237 S7237		Red GaAsP Yellow Green Pure Green Orange Red GaP Red GaAlAs Low Current Red	1.9 3.7 4.3 3.7 4.7 3.7 4.5		5.0 9.8 11.4 9.8 12.8 9.8 12.5	
	S1136 S2136 S3136 S3136P S4136 S5136 S7136		S1236 S2236 S3236 S3236P S4236 S5236 S7236		Red GaAsP Yellow Green Pure Green Orange Red GaP Red GaAlAs Low Current Red	1.9 3.7 4.3 3.7 4.7 3.7 4.5		5.0 9.8 11.4 9.8 12.8 9.8 12.5	

HOLDER TYPE

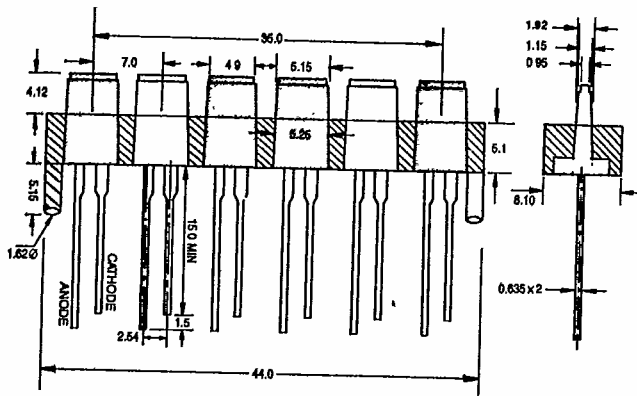

H-1 1x5m/m ARRAY SOCKET 6 SEGUENT

As sample in P25-58

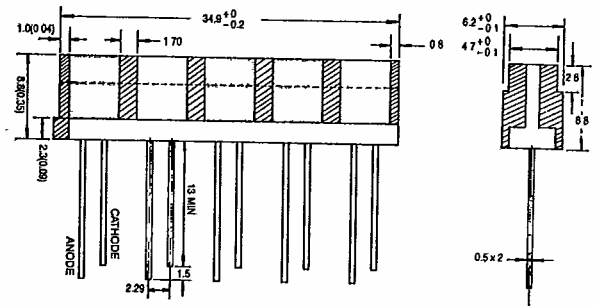

H-2 1.8x5.3m/m ARRAY SOCKET 5 SEGUENT

As sample in P25-59

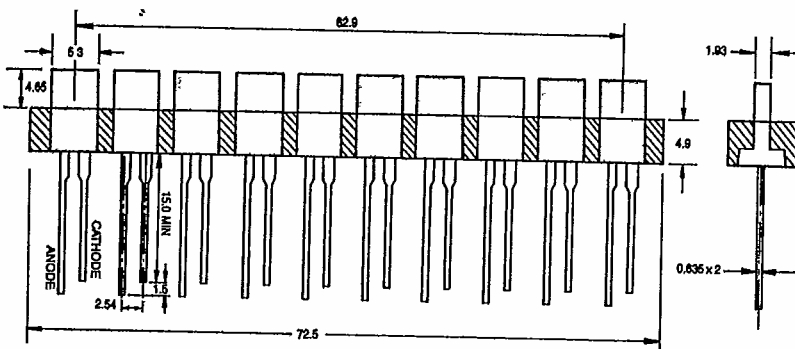

H-3 1.8x5.3m/m ARRAY SOCKET 10 SEGUENT

As sample in P25-60

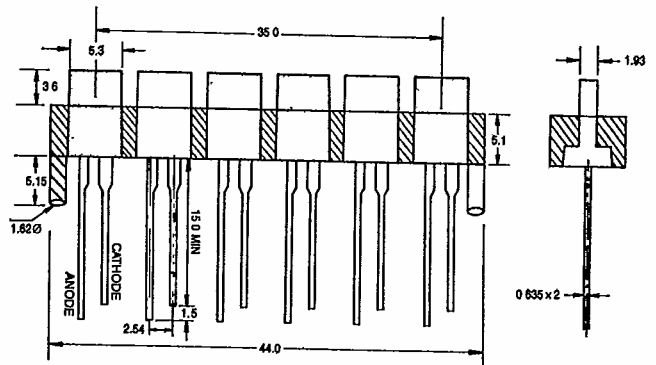

H-4 1.8x5.3m/m ARRAY SOCKET 6 SEGUENT

As sample in P25-61

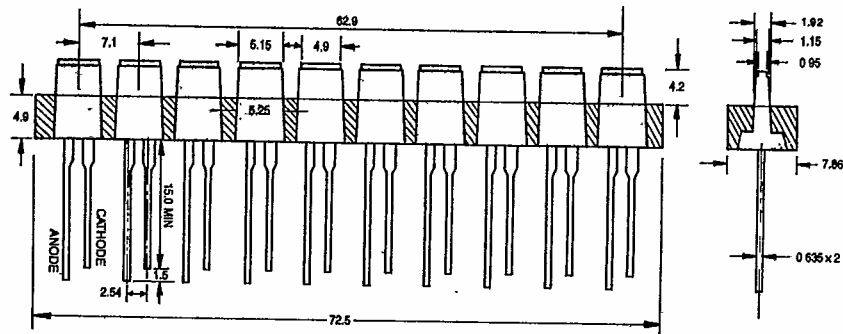

H-5 1x5m/m ARRAY SOCKET 10 SEGUENT

As sample in P25-62

All Dimensions are in millimeters.
Tolerance is $\pm 0.2\text{mm}$

HOLDER TYPE

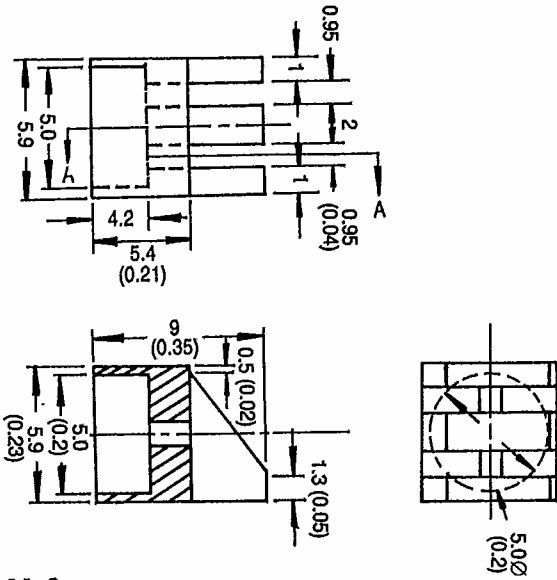
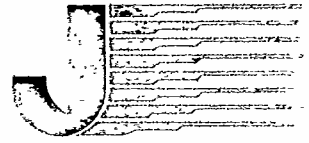

H-6 5m/m

As sample in P25-63

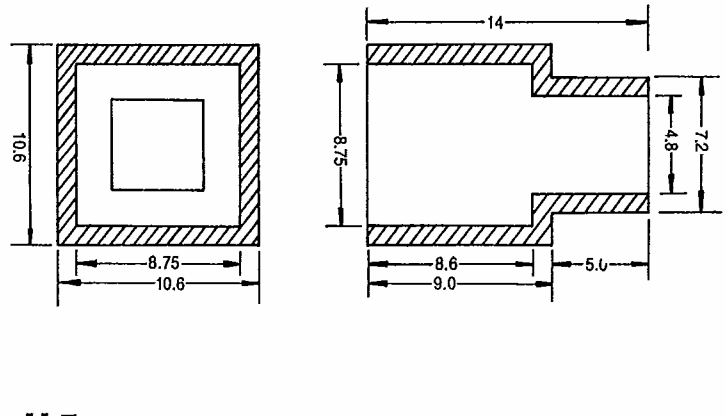

H-7 8x8m/m

As sample in P25-64

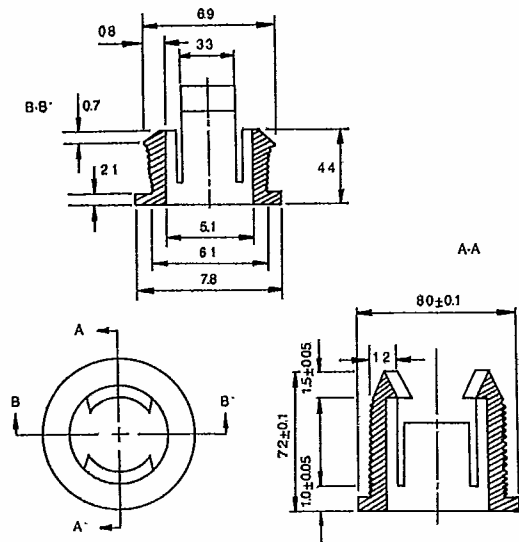

H-8 5m/m

As sample in P25-65

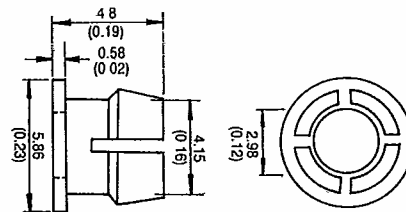

H-9 3m/m

As sample in P25-66

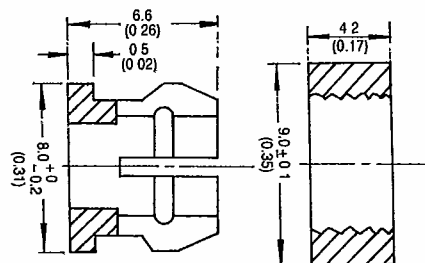

H-10 5m/m

As sample in P25-67

All Dimensions are in millimeters.
Tolerance is ± 0.2 mm