

Panel Controls

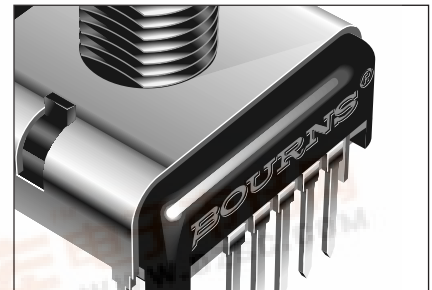

- I. Product Selection Guide.....204
- II. Mounting Hardware.....206
- III. Taper Descriptions207
- IV. Panel Controls
 - 6mm Square.....213
 - 9mm Square.....209
 - 9mm Square with Switch.....209
 - 1/2" (12.5mm) Square.....215
 - 5/8" (16mm) Square.....218, 219, 225
 - 5/8" (16mm) Square with Switch221
 - 3/4" (19mm) Diameter.....228
 - 1/2" (12.7mm) Diameter.....230
- V. Potentiometers
 - Linear Motion208
 - Open Frame Slide.....250
 - Low Profile Open Frame Slide.....252, 254
 - Slimline.....235
 - Rotary
 - 9mm.....243, 248
 - 11mm.....244
 - 12mm.....240
 - 14mm.....246
 - 17mm.....238, 242



Product Selection Guide

BOURNS®

Panel Controls

Model No.	Turns	Element Type	Tolerance	Tapers	Terminal Style	Package Dim.	Multi. Sec. Avail.	Switch Avail.	Page No.
51	Single	<u>Cermet</u> Conductive Plastic	$\pm 5\%$, $\pm 10\%$ $\pm 10\%$, $\pm 20\%$	Linear, Audio	In-line PC Pins 2.54mm Centers	1/2" (12.5mm)	Yes	No	215
53	Single	<u>Cermet</u> Conductive Plastic	$\pm 5\%$, $\pm 10\%$ $\pm 10\%$, $\pm 20\%$	Linear, Audio	Solder Lugs	1/2" (12.5mm)	Yes	No	215
81	Single	<u>Cermet</u> Conductive Plastic	$\pm 5\%$, $\pm 10\%$ $\pm 10\%$, $\pm 20\%$	Linear, Audio	PC Pins L-Pattern	5/8" (16mm)	Yes	No	218
82	Single	<u>Cermet</u> Conductive Plastic	$\pm 5\%$, $\pm 10\%$ $\pm 10\%$, $\pm 20\%$	Linear, Audio	J-Hooks L-Pattern	5/8" (16mm)	Yes	No	218
83	10	<u>Wirewound</u> Hybritron®	$\pm 5\%$ $\pm 10\%$	Linear	PC Pins	5/8" (16mm)	Yes	No	219
84	10	<u>Wirewound</u> Hybritron®	$\pm 5\%$ 10%	Linear	Solder Lugs	5/8" (16mm)	Yes	No	219
85	Single	Conductive Plastic <u>Cermet</u>		Linear, Audio	PC Pins L-Pattern	5/8" (16mm)	Yes	Yes	221
86	Single	Conductive Plastic <u>Cermet</u>		Linear, Audio	J-Hooks L-Pattern	5/8" (16mm)	Yes	Yes	221
91	Single	Conductive Plastic <u>Cermet</u>	$\pm 10\%$, $\pm 20\%$ $\pm 5\%$, $\pm 10\%$	Linear, Audio	In-line PC Pins	5/8" (16mm)	Yes (2 Max.)	No	225
93	Single	Conductive Plastic <u>Cermet</u>	$\pm 10\%$, $\pm 20\%$ $\pm 5\%$, $\pm 10\%$	Linear, Audio	L-Pattern PC Pins	5/8" (16mm)	Yes (2 Max.)	No	225

Output (Taper) Descriptions – See Chart on Page 207

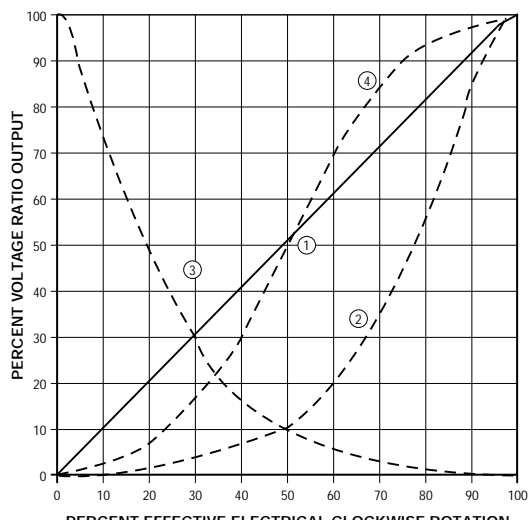

Product Selection Guide

BOURNS®

Panel Controls

Model No.	Turns	Element Type	Tolerance	Tapers	Terminal Style	Package Dim.	Multi. Sec. Avail.	Switch Avail.	Page No.
95	Single	Conductive Plastic Cermet	$\pm 10\%$, $\pm 20\%$ $\pm 5\%$, $\pm 10\%$	Linear, Audio	Triangle Pattern Solder Lugs	5/8" (16mm)	Yes (2 Max.)	No	225
96	Single (Sealed)	Conductive Plastic Cermet	$\pm 10\%$, $\pm 20\%$ $\pm 5\%$, $\pm 10\%$	Linear, Audio	In-line PC Pins (Sealed)	5/8" (16mm)	Yes (2 Max.)	No	225
3310	Single	Conductive Plastic	$\pm 20\%$	Linear	PC Board Bushing Mount	9mm	2 Max.	Yes	209
3370	Single	Conductive Plastic	$\pm 20\%$	Linear	PC Board Bushing Mount	6mm	2 Max.	No	213
3851	Single	Conductive Plastic	$\pm 10\%$, $\pm 20\%$	Linear, Audio	PC Pins, Solder Lugs	3/4" (19mm)	No	No	228
3852	Single	Cermet	$\pm 5\%$, $\pm 10\%$	Linear, Audio	PC Pins, Solder Lugs	3/4" (19mm)	No	No	228
3856	3-3/4	Cermet	$\pm 5\%$, $\pm 10\%$	Linear, Audio	PC Pins, Solder Lugs	3/4" (19mm)	No	No	228
3862	Single	Cermet	$\pm 5\%$, $\pm 10\%$	Linear, Audio	PC Pins, J-Hooks	1/2" (12.7mm)	No	No	230

Open Frame Slide Potentiometers

Model Series	Sections	Stroke Length	Terminal Styles	Element Types/Tapers	Page No.
SS	Single	10mm 15mm 20mm 30mm	PC Pins Horizontal and Vertical	Linear, LH Audio, RH Audio, "S" Curve	232

Slimline Potentiometers

Model Series	Tapers	Tolerance	Standard Resistance Range	Terminal Styles	Sections	Page No.
PC . . .	Linear CP CW Audio CP CCW Audio CP	$\pm 20\%$	500 Ω to 2.5 M Ω	PC Pin, Solder Lug	Single	235

Product Selection Guide



Mounting Hardware

Panel control mounting hardware is determined by bushing style. The "X" in the bushing style column indicates what hardware is used with that bushing. Hardware indicated by shaded area is normally supplied with unit. Other hardware may be ordered separately. Hardware is bulk packaged with units.

Part Number and Description	Bushing Style												
	A/S ENS	B	C	E	J	N	R	T	U	L	W	3310/ 3370	S Mod. 50
H-36-1 Flat Washer			X	X		X		X					
H-36-2 Flat Washer	X	X			X								
H-37-1 Lockwasher			X	X		X		X					X
H-37-2 Lockwasher	X	X			X					X	X		
H-38-1 Mounting Nut			X	X		X		X				X	
H-38-2 Mounting Nut	X	X			X								
H-38-3 Lock Nut				X				X					
H-38-4 Lock Nut		X											
H-37-3 Lockwasher									X				
H-37-4 Lockwasher							X					X	
H-37-5 Lockwasher												X	
H-38-8 M-7 Mounting Nut									X				
H-38-9 M-10 Mounting Nut							X						
H-38-11 M-9 Mounting Nut										X	X		
H-38-14 M6 Mounting Nut													X

Panel Control Options Matrix

	3851	3852	3856	3862	81/82	83/84	85/86	91-96	PC	50	EC	EN	3310/ 3370
Single Section	X	X	X	X	X	X	*	X	X	X	X	X	X
Dual Section					X	X	X*	X		X			X
Triple Section					X	Δ	Δ	Δ		X			
Quad Section					X	Δ	Δ	Δ		X			
.125" Shafts	X	X	X	X	X	X	X	X		X		X	X
.185" Shafts									X		X		
.250" Shafts	X	X	X		X	X	X	X		X	X	X	X
3mm Shaft										X			
4mm Shaft					X	X	X	X		X			
6mm Shaft					X	X	X	X	X	X	X		
Dual Concentric Shafts					X	X	Δ			Δ			
Switches							X*						X
Locking Bushing	X	X		X	X	X				Δ			

ΔConsult factory. *Standard Construction - 1 pot section and 1 switch module.

Product Selection Guide

BOURNS®

Taper Descriptions – See Graph on Page 204

Graph	Models	Taper Code	Description	Linearity	T.R. Tol.
1	81,82,85,86,91-96,3852,3856,3862,50	A	Linear — Cermet	±5% Ind.	±10%
1	81,82,85,86,91-96,3851,50	B	Linear — C.P.	±5% Ind.	±20%
2	81,82,85,86,91-96,3852,3856,50	C	CW Audio — Cermet	N/A	±10%
2	81,82,85,86,91-96,3851,50	D	CW Audio — C.P.	N/A	±20%
1	81,82,85,86,91-96,3851,50	E	Linear — C.P.	±5% Ind.	±10%
3	81,82,85,86,91-96,3852,3856,50	F	CCW Audio — Cermet	N/A	±10%
3	81,82,85,86,91-96,3851,50	G	CCW Audio — C.P.	N/A	±20%
1	81,82,85,86,91-96,3852,3856,3862	H	Linear — Cermet	±5% Ind.	±5%
1	83,84	J	Linear — Wirewound	±.25% Ind.	±10%
1	83,84	K	Linear — Hybritron® Element	±.25% Ind.	±10%
2	81,82,85,86,91-96,50	S	CW Audio — C.P.	N/A	±10%
3	81,82,85,86,91-96,50	T	CCW Audio — C.P.	N/A	±10%
4	50	Y	Dual Audio — C.P.	N/A	±20%
1	3310,3370	N/A	Linear -- C.P.	±5% Ind.	±20%

Consumer Controls / Rotaries

Series	Element Type	Tolerance	Terminal Style	Package Dimension	Shaft Type	Multi Sec. Available	Switch Available	Page Number
PDA17	Carbon	20%	Solder Lugs PC Pins	17mm	Metal	No	Yes	238
PDB12	Carbon	20%	PC Pins	12mm	Insulated	No	No	240
PDB18	Carbon	20%	Solder Lugs PC Pins	17mm	Metal	Yes (2 Max.)	No	242
PTV09	Carbon	20%	PC Pins	9mm	Insulated	No	No	243
PTV111 PTT111	Carbon	20%	PC Pins	11mm	Insulated	No	No	244
PTV142	Carbon	20%	PC Pins	14mm	Insulated	Dual-Sec. Potentiom.	No	246
PTD90 PTR90	Carbon	20%	PC Pins	9mm	Metal	Yes (6 Max.)	Yes	248

Consumer Controls / Sliders

Series	Element Type	Tolerance	Body Type	Terminal Style	Lever Type	Travel in mm	Multi Sec. Available	Page Number
PDV	Carbon	20%	Open Frame	PC Pins	Insulated	10, 15, 20, 30	Yes (2 Max.)	250
PTA	Carbon	20%	Enclosed Body	PC Pins	Metal & Insulated	15, 20, 30 45, 60	Yes (2 Max.)	252
PTB	Carbon	20%	Enclosed Body	PC Pins	Metal	45, 60, 100	Yes (2 Max.)	254

Tapers: Audio and Linear (other std. taper on request)

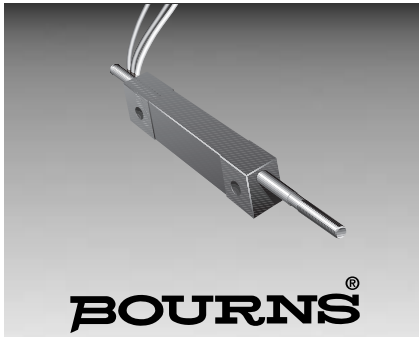

Features

- Compact
- Lightweight
- Long life
- Infinite resolution
- Free shaft rotation
- AC or DC
- Shaft options available
- Flexible wire leads
- Economical

3048 Linear Motion Potentiometer

Specifications*

Standard Electrical Travel
0.2, 0.3, 0.4, 0.5 in.
 (5.08, 7.62, 10.16, 12.70mm)

Standard Resistances
1K ohms to 1 megohm ($\pm 20\%$)

Independent Linearity $\pm 5\%$

ResolutionInfinite

Power Rating @ 70°C (158°F)
 Range 2, 30.12 watt
 Range 4, 50.25 watt

Operating Temperature Range
-55°C to +125°C

Temperature Coefficient 1000 PPM/°C

Insulation Resistance50 megohms
 @ 500 VDC

BacklashNegligible

Shaft Actuating Force4 oz. max.
 @ 70°F

Life500,000 cycles

Shock50G for 6msec

Vibration20G, 20-20,000 Hz

MarkingManufacturer's trademark,
 resistance code, wiring diagram,
 date code, manufacturer's model
 number and style

Specifications are typical. Contact factory for special requirements.
 *Specifications applicable from 5% to 95% of electrical travel.

How to Order

Model 3048 L - 2 - 502

Style _____

Range (Travel) _____
 2 = 0.2" (5.08mm)
 3 = 0.3" (7.62mm)
 4 = 0.4" (10.16mm)
 5 = 0.5" (12.70mm)

Resistance Value _____

Standard Resistance Table

Resistance (Ohms)	Resistance Code
1,000	102
2,500	252
5,000	502
10,000	103
20,000	203
50,000	503
100,000	104
200,000	204
500,000	504
1,000,000	105

Product Dimensions

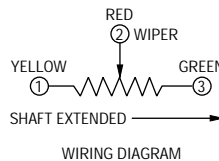
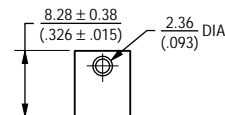
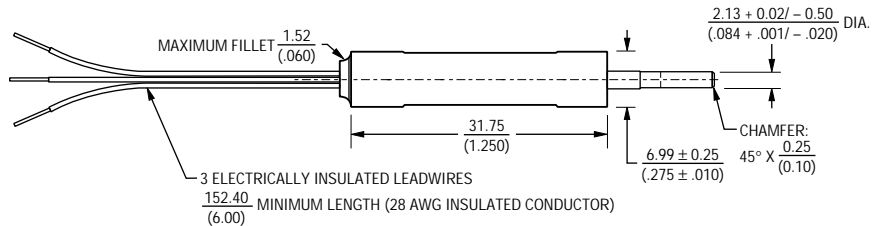
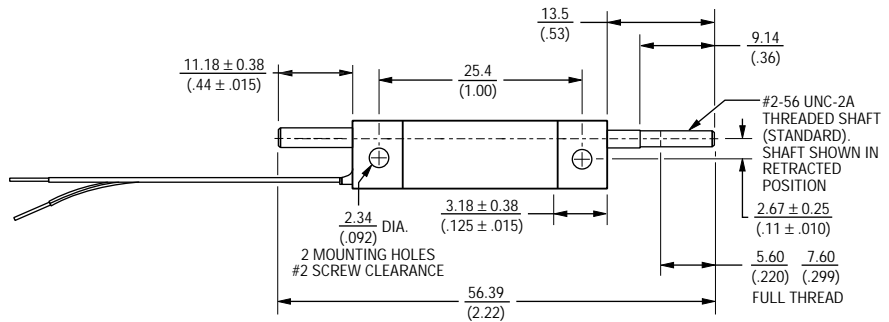

TOLERANCES: $\pm \frac{.010}{(0.25)}$ EXCEPT WHERE NOTED

DIMENSIONS ARE: METRIC
 (INCHES)

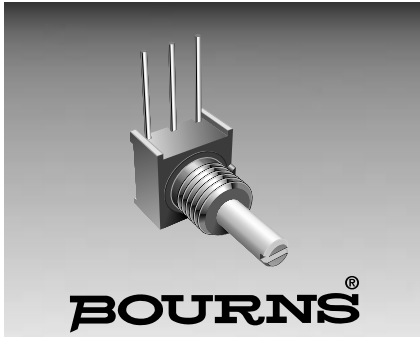

Features

- Conductive plastic
- Linear and audio tapers
- PC board and bushing mount
- Plastic bushing and plastic shaft
- Withstands typical industrial washing processes

- Compact package saves board and panel space

3310 - 9mm Square Sealed Panel Control

Electrical Characteristics

Standard Resistance Range - Linear	1K ohms to 1 megohm
Total Resistance Tolerance - Linear Tapers	±20%
Independent Linearity	±5%
Absolute Minimum Resistance	2 ohms maximum
Effective Electrical Angle	270° ±15°
Contact Resistance Variation	1% or 1 ohm (whichever is greater)
Dielectric Withstanding Voltage	
Sea Level	900 VAC minimum
70,000 Feet	350 VAC minimum
Insulation Resistance	1,000 megohms minimum
Power Rating @ 70°C (Derate to 0 at 125°C - Voltage Limited By Power Dissipation or 200 VAC, Whichever is Less)	0.25 watts

Environmental Characteristics

Operating Temperature	+1°C to +125°C
Storage Temperature	-55°C to +125°C
TCR (Over Storage Temperature Range)	±1,000ppm/°C
Vibration	30G
Total Resistance Shift	±1% maximum
Voltage Ratio Shift	±1% maximum
Shock	100G
Total Resistance Shift	±1% maximum
Voltage Ratio Shift	±1% maximum
Load Life (1,000 Hours)	±10% TRS maximum
Rotational Life-No Load (50,000 Cycles)	±5% TRS maximum
CRV	±3% or 3 ohms (whichever is greater)
Moisture Resistance	±10% TRS

Mechanical Characteristics

Stop Strength	5.65 Ncm
Mechanical Angle	300° nominal
Torque - Running	3.53 Ncm
Weight	4.5 grams
Flammability	Conforms to UL94V-0
Terminals	Solderable pins
Marking	Manufacturer's symbol and model number, product code, terminal style, date code and resistance code

Standard Resistance Table

Resistance (Ohms)	Resistance Code
1,000	102
2,000	202
5,000	502
10,000	103
20,000	203
50,000	503
100,000	104
200,000	204
500,000	504
1,000,000	105

Popular values listed in boldface. Consult factory for special resistances.

Part Numbering System

Model Number Designator	3310 Y - 0 0 1 - 103
3310 = 9mm Panel Control	
Terminal Style Designator	Y
Single Cup:	
C = In-line Straight Terminals Side Exit 2.54 mm centers	
R = In-line Terminals Rear Exit 2.54 mm centers	
P = 5.08mm x 2.54mm Triangular Pattern Rear Exit	
Y = 5.08mm x 5.08mm Triangular Pattern Rear Exit	
Dual Cup (Pot/Pot or Pot/Switch):	
H = Dual In-line Straight Terminals Rear Exit 2.54 mm centers	
Shaft End Designator	0 0
0 = Shaft End Slotted	
1 = Shaft End Flatted	
Shaft Length Designator	1
0 = 12.7mm FMS Long Plastic Shaft	
1 = 19.05mm FMS Long Plastic Shaft (Use with bushing version only)	
2 = 5.59mm FMS Long Plastic Shaft (Bushingless version only)	
Bushing Designator	0 0
Pot (or Pot/Pot):	
1 = 6.35mm x 6.35mm Plastic	
2 = 6.35mm x 6.35mm Ni Plated Brass	
5 = Bushingless (Board Level Control)	
Pot/Switch Bushing Designator (use with "H" terminal style only):	
3 = 6.35mm x 6.35mm Plastic	
4 = 6.35mm x 6.35mm Ni Plated Brass	
6 = Bushingless (Board Level) Pot/Switch	
Resistance Code	1 - 103
(1st 2 digits are significant, 3rd digit is number of 0s to follow)	

3310 - Dimensions and Tolerances



COMMON DIMENSIONS

3310-001

Plastic Bushing
Slotted Shaft

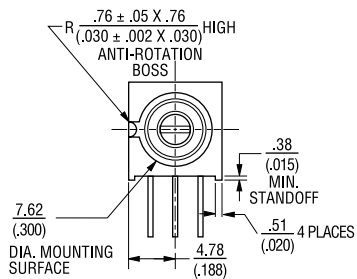
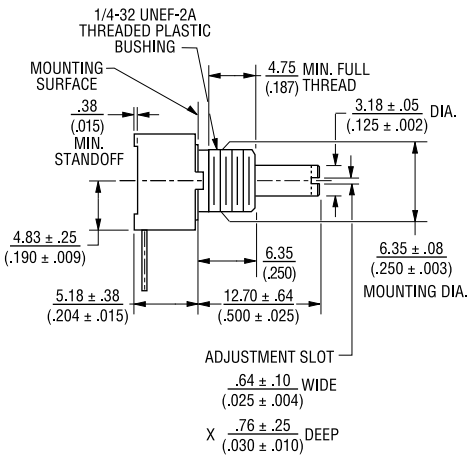
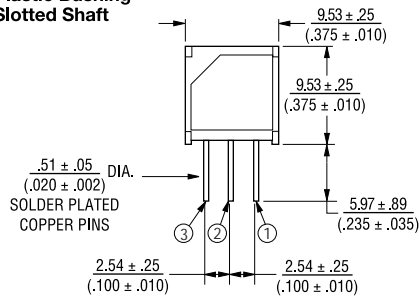

3310C-001

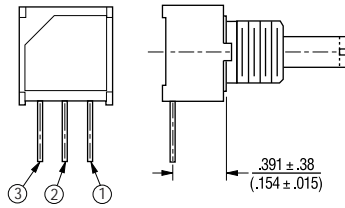

3310P-001

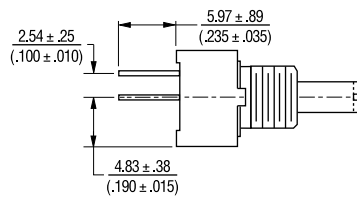
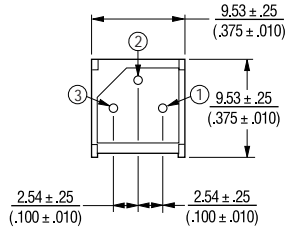

3310R-001

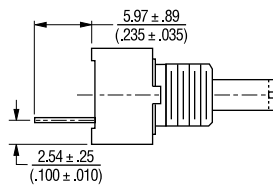
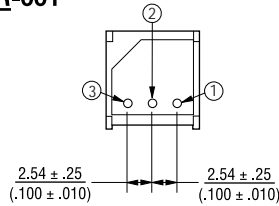

3310Y-001

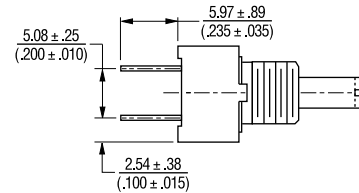
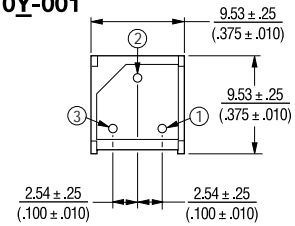

COMMON DIMENSIONS

3310C-101

Plastic Flatted Shaft

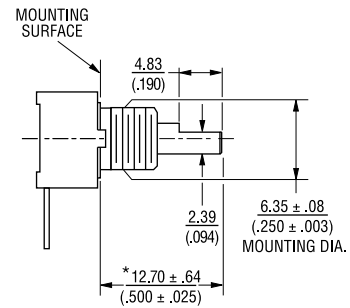

*FMS = From Mounting Surface

DIMENSIONS ARE: METRIC / (INCHES)

3310 - Dimensions and Tolerances



COMMON DIMENSIONS 3310-002 Metal Bushing

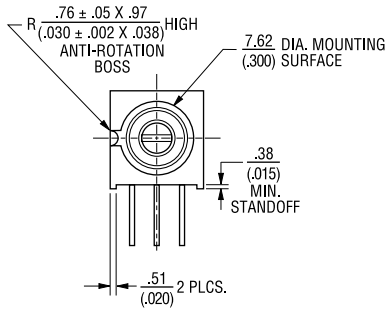
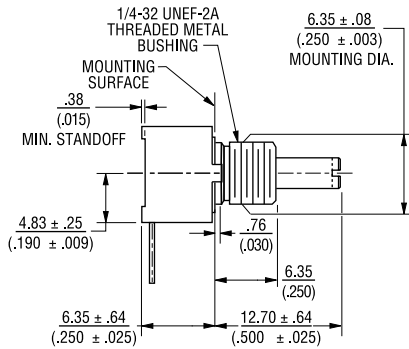

3310P-005* Bushingless

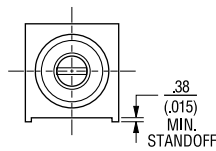
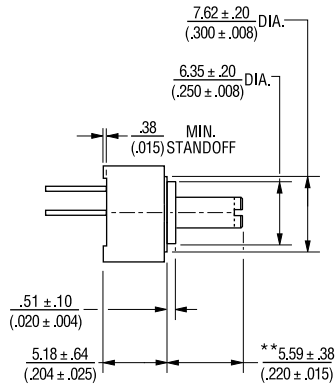

3310C-002

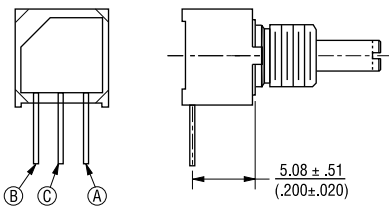

DIMENSIONS ARE: METRIC
(INCHES)

NOTE: *Also available in "Y" terminal style

**Only recommended shaft length
for bushingless version

3310 - Dimensions and Tolerances



Common Dimensions 3310H-003 Pot/Switch Dual Cup Plastic Bushing

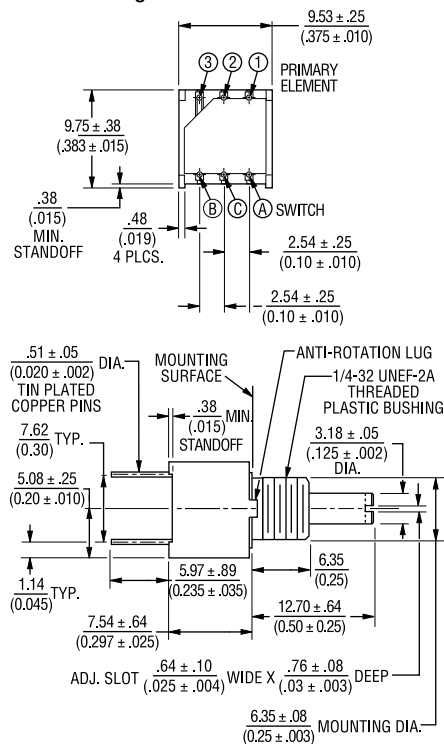

3310H-005 Pot/Pot Dual Cup, Bushingless

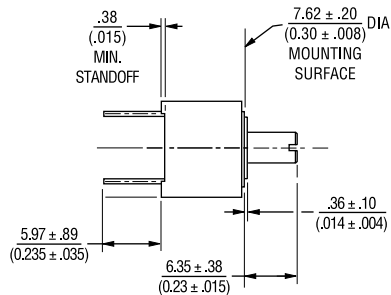
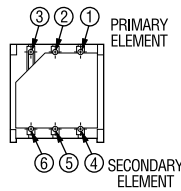

3310H-002 Pot/Pot Dual Cup, Metal Bushing

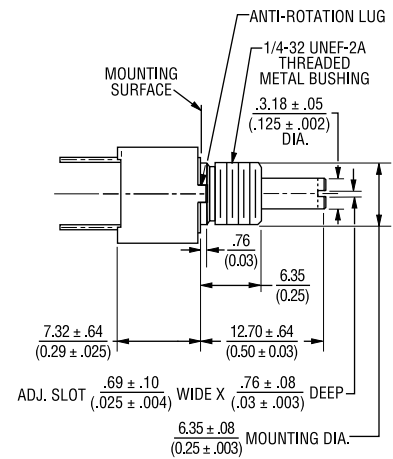
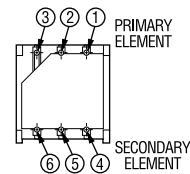

Pot/Pot Dual Cup

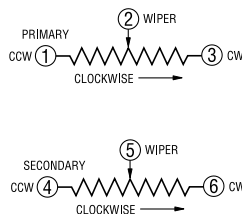

Pot/Switch Dual Cup

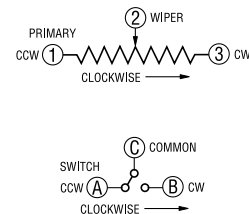

DIMENSIONS ARE: METRIC
(INCHES)

Pot Single Cup

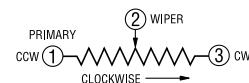

NOTE: *Also available in "Y" terminal style
**Only recommended shaft length
for bushingless version

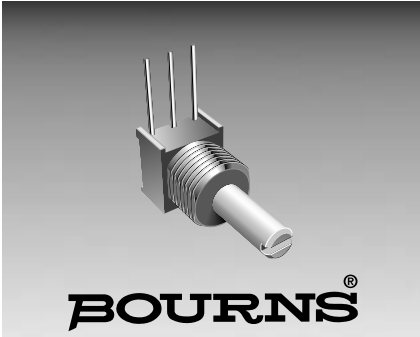

Features

- Conductive plastic
- Linear and audio tapers
- PC board and bushing mount
- Plastic bushing and plastic shaft
- Withstands typical industrial washing processes

3370 - 6mm Square Sealed Panel Control

Electrical Characteristics

Standard Resistance Range1K ohms to 1 megohm
Linear
Total Resistance Tolerance±20%
Linear Tapers±5%
Independent Linearity±5%
Absolute Minimum Resistance2 ohms maximum
Effective Electrical Angle240° nominal
Contact Resistance Variation1 ohm or 1% (whichever is greater)
Dielectric Withstanding Voltage
Sea Level900 VAC minimum
70,000 Feet350 VAC minimum
Insulation Resistance1,000 megohms minimum
Power Rating @ 70°C (Derate to 0 at 125°C - Voltage Limited By Power Dissipation or 200 VAC, Whichever is Less)25 watts

Environmental Characteristics

Storage Temperature-55°C to +125°C
TCR (Over Storage Temperature Range)±1,000ppm/°C
Vibration30G
Total Resistance Shift±2% maximum
Voltage Ratio Shift±2% maximum
Shock100G
Total Resistance Shift±2% maximum
Voltage Ratio Shift±2% maximum
Load Life (1,000 Hours)±10% TRS maximum
Rotational Life-No Load (50,000 Cycles)±5% TRS maximum
CRV3 ohms or 3% whichever is greater
Moisture Resistance±10% TRS

Mechanical Characteristics

Stop Strength5.65 Ncm
Mechanical Angle310° nominal
Torque
Starting1.41 Ncm Max.
Weight4.5 grams
FlammabilityConforms to UL94V-0
EpoxyConforms to UL94V-1
TerminalsSolderable pins
MarkingManufacturer's symbol and model number, product code, terminal style, date code and resistance code

Standard Resistance Table

Resistance (Ohms)	Resistance Code
1,000	102
2,000	202
5,000	502
10,000	103
20,000	203
50,000	503
100,000	104
200,000	204
500,000	504
1,000,000	105

Popular values listed in boldface. Consult factory for special resistances.

Part Numbering System

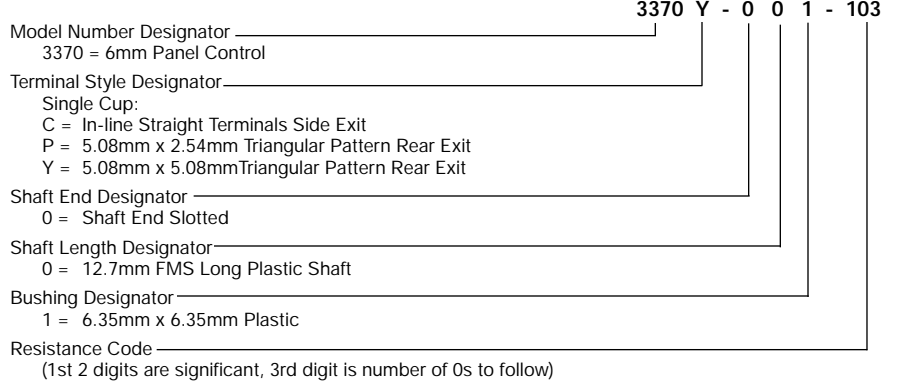

3370 - Dimensions and Tolerances



COMMON DIMENSIONS 3370C

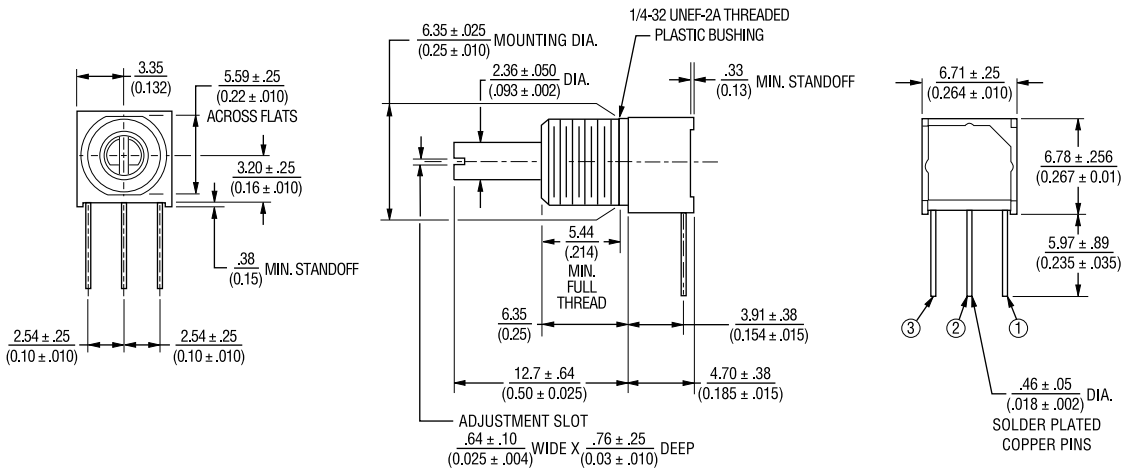

3370P

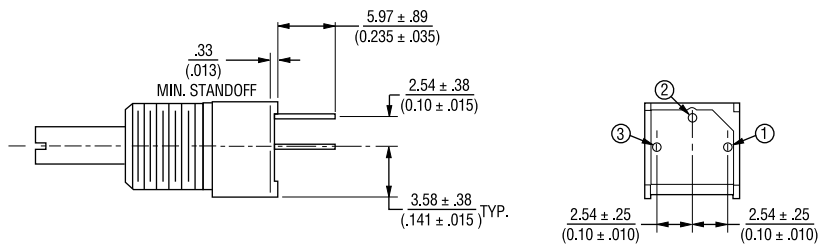

3370Y

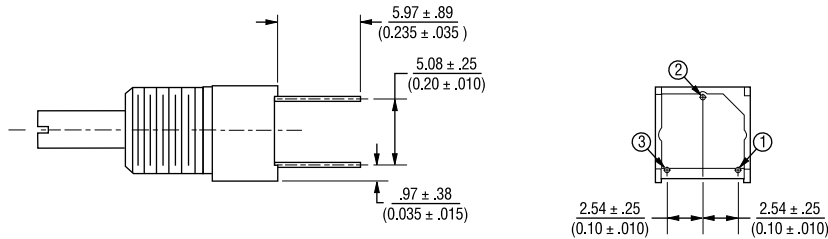

DIMENSIONS ARE: $\frac{\text{METRIC}}{\text{(INCHES)}}$

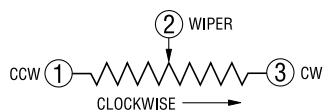

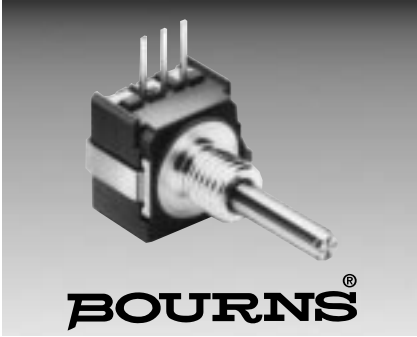

Features

- Conductive plastic or cermet
- Linear and audio tapers
- PC board and bushing mount
- Gangable
- Metal bushing and shaft
- Sealed for board washing

50 Series - Sealed 1/2" (12.5mm) Square Control

Electrical Characteristics ¹	Conductive Plastic	Cermet
Standard Resistance Range		
Linear.....	1K ohms to 1 megohm.....	150 ohms to 1 megohm
Audio.....	1K ohms to 1 megohm.....	1K ohms to 1 megohm
Total Resistance Tolerance		
Linear Tapers.....	±10% OR ±20%.....	±10% OR ±5%
Audio Tapers.....	±10% OR ±20%.....	±10%
Independent Linearity.....	±5%.....	±5%
Absolute Minimum Resistance.....	2 ohms maximum.....	2 ohms maximum
Effective Electrical Angle.....	270°±5°.....	270°±5°
Contact Resistance Variation.....	2.0%.....	2.0%
Dielectric Withstanding Voltage		
Sea Level.....	1,500 VAC minimum.....	1,500 VAC minimum
70,000.....	500 VAC minimum.....	500 VAC minimum
Insulation Resistance.....	1,000 megohms minimum.....	1,000 megohms minimum
Power Rating At 70°C (Derate To 0 At 125°C) (Voltage Limited By Power Dissipation or 350 VAC, Whichever Is Less)		
Linear Tapers.....	0.5 watt.....	1.0 watt
Audio Tapers.....	0.25 watt.....	0.5 watt
Tracking (Multiple Sections).....	3 db.....	3 db

Environmental Characteristics ¹	Conductive Plastic	Cermet
Operating Temperature.....	+1°C to +125°C.....	+1°C to +125°C
Storage Temperature.....	-55°C to +125°C.....	-55°C to +125°C
TCR (Over Storage Temperature Range).....	±1,000ppm/°C.....	±150ppm/°C
Vibration (Single Section).....	15G.....	15G
Total Resistance Shift.....	±2% maximum.....	±2% maximum
Voltage Ratio Shift.....	±5% maximum.....	±5% maximum
Shock (Single Section).....	30G.....	30G
Total Resistance Shift.....	±2% maximum.....	±2% maximum
Voltage Ratio Shift.....	±5% maximum.....	±5% maximum
Load Life (1,000 Hours).....	±10% TRS maximum.....	±5% TRS maximum
Rotational Life-No Load (50,000 Cycles) ²	±10% TRS maximum.....	±10% TRS maximum
CRV @ 25,000 Cycles.....	±2%.....	±4%
Moisture Resistance.....	±10% TRS.....	±5% TRS

Mechanical Characteristics	Conductive Plastic	Cermet
Stop Strength.....	5 in.-lb.....	5 in.-lb.
Mechanical Angle.....	290° ±5°.....	290° ±5°
Torque		
Running (Single Section).....	0.2 to 2.0 oz.-in. (0.15 to 1.4Ncm).....	0.2 to 2.0 oz.-in. (0.15 to 1.4 Ncm)
Running (Dual or Triple Section).....	0.5 to 2.5 oz.-in. (0.35 to 1.8 Ncm).....	0.5 to 2.5 oz.-in. (0.35 to 1.8 Ncm)
Starting (All Sections).....	Running torque +0.5 oz.-in. (+0.35 Ncm) maximum.....	Running torque +0.5 oz.-in. (+0.35 Ncm) maximum
Weight (Single Section).....	5.5 grams.....	5.5 grams
Each Additional Section.....	3.0 grams.....	3.0 grams
Terminals.....	PC pin or solder lug.....	PC pin or solder lug
Marking.....	Manufacturer's symbol and part number, date code and resistance value	

¹At room ambient: +25°C nominal and 50% relative humidity nominal, except as noted.

²Conductive Plastic, 25,000 cycles for cermet elements.

50 Series - Dimensions and Tolerances



PACKAGE DIMENSIONS

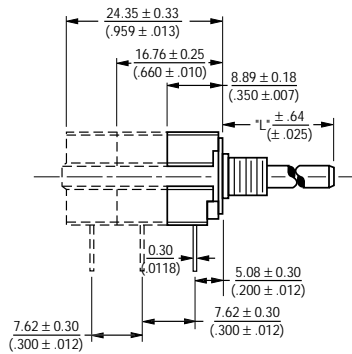

(SINGLE, DUAL AND TRIPLE MODULE SHOWN)
AVAILABLE IN 1 THROUGH 6 MODULE VERSIONS.

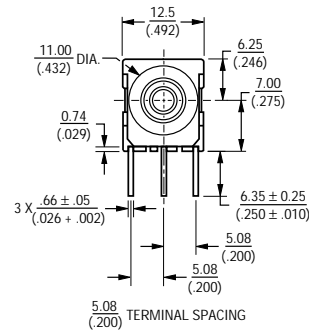
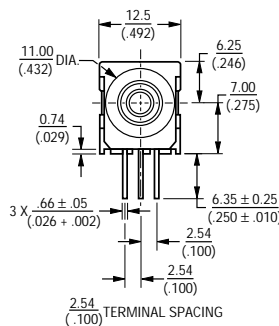

PACKAGE DIMENSIONS PCB MOUNTING BRACKET

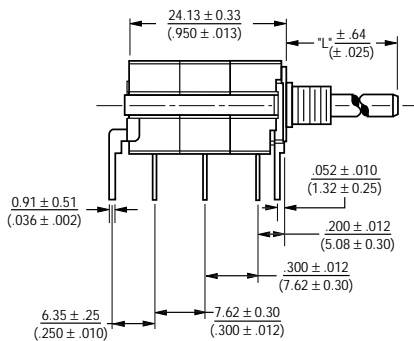

AVAILABLE IN 1 THROUGH 6 MODULE VERSIONS.

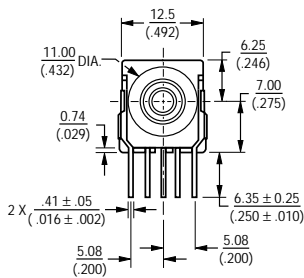

SOLDER LUG TERMINALS

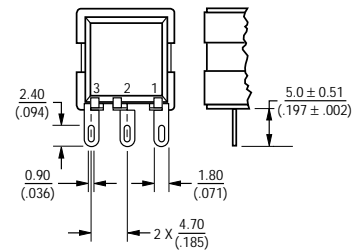

ELECTRICAL SCHEMATIC

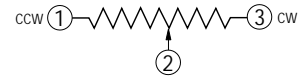

ANTI-ROTATION LUG (Style "A", 90° CW Shown)

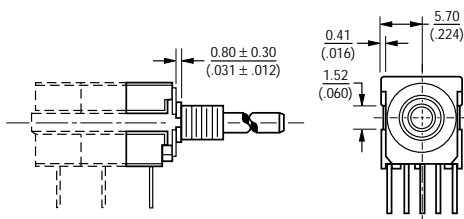

SHAFT FLAT ORIENTATION

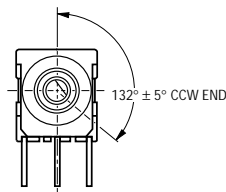

SUGGESTED PANEL LAYOUTS

The Model 50 can be used with either of the two panel layouts shown below.

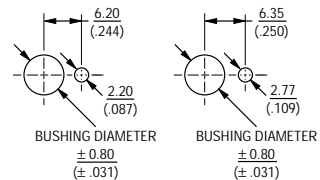

FOR TOLERANCES SHOWN: .XX ± .25 (.010)
.XXX ± .13 (.005)
SHAFT DIMENSIONS ± .80 (1/32)

DIMENSIONS ARE: METRIC (INCHES)

50 Series- Dimensions and Tolerances



Shaft/Bushing Styles

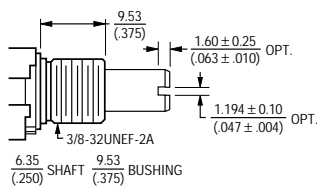

A Style Bushing

STD. LENGTH 'L'
.500 (12.7)
.625 (15.88)
.750 (19.05)
.875 (22.23)
1.000 (25.4)

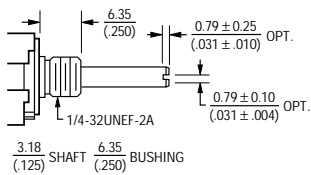

C Style Bushing

STD. LENGTH 'L'
.375 (9.53)
.500 (12.7)
.625 (15.88)
.750 (19.05)
.875 (22.23)
1.000 (25.4)

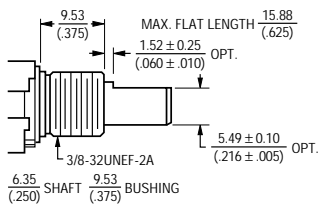

A Style Bushing - Flatted Shaft

STD. LENGTH 'L'
.625 (15.88)
.750 (19.05)
.875 (22.23)
1.000 (25.4)

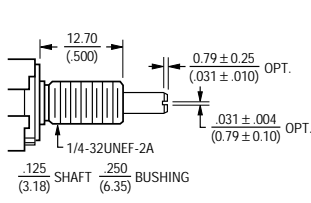

F Style Bushing

STD. LENGTH 'L'
.625 (15.88)
.750 (19.05)
.875 (22.23)
1.000 (25.4)

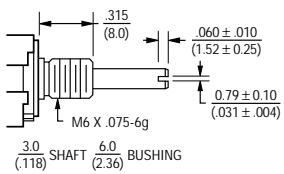

S Style Bushing

STD. LENGTH 'L'
.394 (10.0)
.512 (13.0)
.630 (16.0)
.866 (22.0)
.984 (25.0)

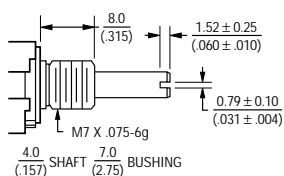

U Style Bushing

STD. LENGTH 'L'
.394 (10.0)
.512 (13.0)
.630 (16.0)
.866 (22.0)
.984 (25.0)

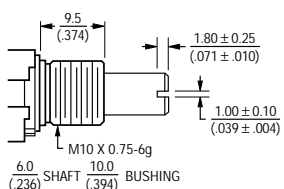

R Style Bushing

STD. LENGTH 'L'
.512 (13.0)
.630 (16.0)
.866 (22.0)
.984 (25.0)

How To Order

51 A A D - B 28 - A 15

MOUNTING BRACKET/ ANTI-ROTATION LUG	
Code	Description
A	AR Lug 90°CW
D	No AR Lug or Bracket

ELEMENT TAPER TYPE/TOLERANCE		RESISTANCE (CODE)	
Code	Description	VALUE IN OHMS	
(A)	Linear Cermet ±10%	(10) — 1K	(18) — 50K
(B)	Linear C-P ±20%	(13) — 5K	(20) — 100K
(D)	CW Audio C-P ±20%	(15) — 10K	

# SECTIONS/DETENTS	
Code	Description
A	Single No Detent
B	Double No Detent

BUSHING CONFIGURATION	
Code	Description
A	3/8"D x 3/8"L
C	1/4"D x 1/4"L
R	10mmD x 9.5mmL
S	6mmD x 8mmL
U	7mmD x 8mmL

SHAFT LENGTH (FMS)		AVAILABLE ONLY IN BUSHING
Code	Description	Code
24	3/4"	A, C, F
28	7/8"	A, C, F
Metric		
16	16mm	R, S, U, T
25	25mm	R, S, U, T

MODEL	
Code	Description
51	PC Pins (.100" centers)
53	Solder Lugs

SHAFT TYPE		AVAILABLE ONLY IN	
Code	Description	BUSHINGS	LENGTHS
B	Single Slotted 1/4"D	A	24,28
E	Single Slotted 1/8"D	C, F	24,28
R	Single Slotted 6mmD	R	25
T	Single Slotted 4mmD	U	25
U	Single Slotted 3mmD	S	16

(Recommended standard P/N's)
For Other Options Contact the Factory
Boldface listings are in stock and readily available
through distribution.

DIMENSIONS ARE: METRIC
(INCHES)

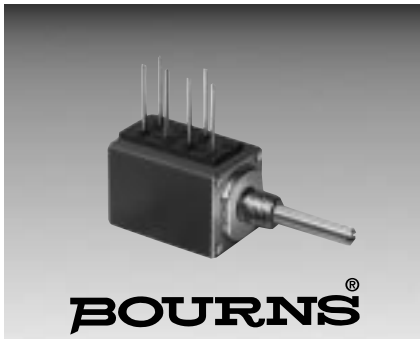

Features

- Metal shaft and bushing
- Consistent, smooth quality feel
- Up to 4 sections available

81/82 - 5/8" Square Single-Turn Conductive Plastic

Initial Electrical Characteristics ¹	Conductive Plastic Element	Cermet Element
Standard Resistance Range		
Linear Tapers (A, B, E, & H).....	(B & E) 1K ohms to 1 megohm.....	(A & H) 50 ohms to 1 megohm
Audio Tapers (C, D, F, G, S, & T).....	(D, G, S, & T) 1K ohms to 1 megohm.....	(C & F) 1K ohms to 1 megohm
Resistance Tolerance.....	(B, D, & G tapers) ±20% (E, S, & T tapers) ±10%	(A, C, & F tapers) ±10% (H taper) ±5%
Independent Linearity.....	(B & E tapers) ±5%	(A & H tapers) ±5%
Absolute Minimum Resistance.....	2 ohms maximum	2 ohms maximum
Continuity.....	Maintained for full mechanical angle	Maintained for full mechanical angle
Effective Electrical Angle.....	240° ±5%	240° ±6°
Contact Resistance Variation.....	±1%	±1% or 3 ohms (whichever is greater)
Theoretical Resolution.....	Essentially infinite.....	Essentially infinite
Dielectric Withstanding Voltage.....	MIL-STD-202, Method 301	MIL-STD-202, Method 301
Sea Level.....	1,500 VAC minimum	1,500 VAC minimum
70,000 Feet.....	500 VAC minimum	500 VAC minimum
Insulation Resistance (500 VDC).....	1,000 megohms minimum	1,000 megohms minimum
Power Rating At 70°C (Voltage Limited By Power Dissipation or 350 VAC, Whichever Is Less)		
+70°C Single Section Assembly.....	(B & E tapers) 0.5 watt (D, G, S & T tapers) 0.25 watt	(A & H tapers) 2 watts (C & F tapers) 1 watt
+70°C Multiple Section Assembly.....	(B & E tapers) 0.5 watt/section (D, G, S & T tapers) 0.25 watt/section	(A & H tapers) 1 watt/section (C & F tapers) 0.5 watt/section
+125°C.....	0 watt	0 watt
Roll-on/Roll-off.....	(B & E tapers) 0.25% maximum (D & S tapers) 0.1% maximum CCW end (G & T tapers) 0.1% maximum CW end (D & S tapers) 0.5% maximum CW end (G & T tapers) 0.5% maximum CCW end	(A & H tapers) 0.5% maximum (C taper) 0.1% maximum CCW end (F taper) 0.1% maximum CW end (C taper) 1.0% maximum CW end (F taper) 1.0% maximum CCW end
Environmental Characteristics¹		
Operating Temperature.....	+1°C to +125°C	+1°C to +125°C
Storage Temperature Range.....	-55°C to +125°C	-55°C to +125°C
Temperature Coefficient		
Over Storage Temperature Range.....	±1,000PPM/°C	±150PPM/°C
Vibration (Single Section).....	15G	15G
Voltage Ratio Shift.....	±5% maximum	±5% maximum
Total Resistance Shift.....	±2% maximum	±2% maximum
Shock (Single Section).....	30G	30G
Voltage Ratio Shift.....	±5% maximum	±5% maximum
Total Resistance Shift.....	±2% maximum	±2% maximum
Load Life.....	1,000 hours	1,000 hours
Total Resistance Shift.....	±10% maximum	±5% maximum
Rotational Life (No Load).....	100,000 cycles	100,000 cycles
Total Resistance Shift.....	(B & E tapers) 10 ohms or ±12% maximum (whichever is greater) (D, G, S & T tapers) ±20% maximum	10 ohms or ±10% maximum (whichever is greater)
Moisture Resistance.....	MIL-STD-202, Method 103, Condition B	MIL-STD-202, Method 103, Condition B
Total Resistance Shift.....	(B & E tapers) ±10% maximum (D, G, S & T tapers) ±20% maximum	±5% maximum (all tapers)
Insulation Resistance (500 VDC).....	100 megohms minimum	100 megohms minimum
Mechanical Characteristics¹		
Running Torque (Non-Locking Bushings)		
Single Section.....	0.2 to 1.5 oz.-in. (0.14 to 1.06 Ncm)	0.2 to 1.5 oz.-in. (0.14 to 1.06 Ncm)
Dual Section.....	0.2 to 1.5 oz.-in. (0.14 to 1.06 Ncm)	0.2 to 1.5 oz.-in. (0.14 to 1.06 Ncm)
Triple Section.....	0.5 to 2.0 oz.-in. (0.35 to 1.41 Ncm)	0.5 to 2.0 oz.-in. (0.35 to 1.41 Ncm)
Quadruple Section.....	0.5 to 2.0 oz.-in. (0.35 to 1.41 Ncm)	0.5 to 2.0 oz.-in. (0.35 to 1.41 Ncm)
Running Torque (Locking Bushings).....	0.2 to 4.0 oz.-in. (0.14 to 2.82 Ncm)	0.2 to 4.0 oz.-in. (0.14 to 2.82 Ncm)
Shaft Locking Torque with Locknut		
@ 10 in.-lb. (B & E Bushings).....	20 oz.-in.	20 oz.-in.
Stop Strength.....	1/4" (6.35mm) and 1/8" (3.18mm) shafts - 4 in.-lb. (45.19 Ncm) min.	1/4" (6.35mm) and 1/8" (3.18mm) shafts - 4 in.-lb. (45.19 Ncm) min.
Mechanical Angle.....	300° ±5°	300° ±5°
Weight (Single Section).....	21 grams maximum	21 grams maximum
Each Additional Section.....	6 grams maximum	6 grams maximum
Terminals.....	Printed circuit terminals or J-Hooks	Printed circuit terminals or J-Hooks
Marking.....	Manufacturer's trademark, wiring diagram, date code and resistance, manufacturer's part number	

For dimensional drawings see page 222.

NOTE: Model 81/82 performance specifications do not apply to units subjected to printed circuit board cleaning procedures.

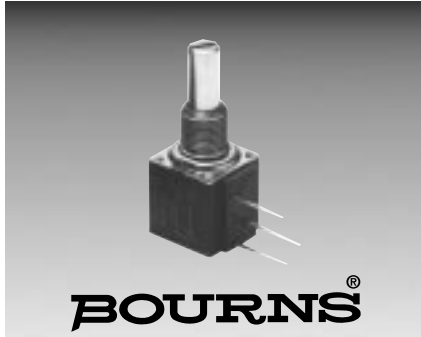

Features

- Compatible with other members of the Model 80 Series
- The only 10-turn precision potentiometer in a modular panel control package
- Up to 3 sections available

83/84 - 5/8" Square 10-Turn

Initial Electrical Characteristics¹

	Wirewound Element (J Taper)	Hybriton® Element (K Taper)
Standard Resistance Range	200 to 100K ohms	1K to 100K ohms
Resistance Tolerance	±5%	±10%
Independent Linearity	±0.25%	±0.25%
Effective Electrical Angle	3600° +10°, -0°	3600° +10°, -0°
Minimum Resistance (J Taper)	1.0 ohm or 0.1% (whichever is greater)	-
End Voltage (K Taper)	-	0.2% of applied voltage
Noise (J Taper)	100 ohms ENR maximum	-
Output Smoothness (K Taper)	-	0.15% maximum
Dielectric Withstanding Voltage	MIL-STD-202, Method 301	MIL-STD-202, Method 301
Sea Level	1,500 VAC minimum	1,500 VAC minimum
Insulation Resistance (500 VDC)	1,000 megohms minimum	1,000 megohms minimum
Power Rating (Voltage Limited By Power Dissipation or 316 VAC, Whichever Is Less)		
+70°C	1 watt	1 watts
+125°C	0 watt	0 watt
Theoretical Resolution	See table	Essentially infinite

Environmental Characteristics¹

Operating Temperature	+1°C to +125°C	+1°C to +125°C
Storage Temperature Range	-55°C to +125°C	-55°C to +125°C
Temperature Coefficient		
Over Storage Temperature Range	±50PPM/°C	±100PPM/°C
Vibration	15G	15G
Wiper Bounce	0.1 millisecond maximum	0.1 millisecond maximum
Shock	50G	50G
Wiper Bounce	0.1 millisecond maximum	0.1 millisecond maximum
Load Life	1,000 hours	1,000 hours
Total Resistance Shift	±2% maximum	±5% maximum
Rotational Life (No Load)	1,000,000 shaft revolutions	4,000,000 shaft revolutions
Total Resistance Shift	±5% maximum	±5% maximum
Moisture Resistance	MIL-STD-202, Method 103, Condition B	MIL-STD-202, Method 103, Condition B
Total Resistance Shift	±2% maximum	±5% maximum
Insulation Resistance (500 VDC)	100 megohms minimum	100 megohms minimum

Mechanical Characteristics¹

Mechanical Angle	3600° +15°, -0°	3600° +15°, -0°
Shaft Runout	0.006 in. (0.15mm) T.I.R.	0.006 in. (0.15mm) T.I.R.
Shaft End Play	0.014 in. (0.36mm) T.I.R.	0.014 in. (0.36mm) T.I.R.
Shaft Radial Play	0.005 in. (0.13mm) T.I.R.	0.005 in. (0.13mm) T.I.R.
Stop Strength	48.0 oz.-in. (33.90 Ncm) minimum	48.0 oz.-in. (33.90 Ncm) minimum
Running Torque (1 or 2 Section)	0.25 to 2.0 oz.-in. (0.18 to 1.41 Ncm)	0.25 to 2.0 oz.-in. (0.18 to 1.41 Ncm)
Weight	Approximately 0.75 oz.-in. (0.53 Ncm)	Approximately 0.75 oz.-in. (0.53 Ncm)
Terminals	Printed circuit terminals or solder lugs	Printed circuit terminals or solder lugs
Marking	Manufacturer's trademark, wiring diagram, date code and resistance, manufacturer's part number	Manufacturer's trademark, wiring diagram, date code and resistance, manufacturer's part number

Wirewound Resolution Table

Resistance (Ohms)	Resolution (Nom.) (%)
200	.048
500	.037
1K	.032
2K	.031
5K	.023
10K	.020
20K	.015
50K	.012
100K	.010

Dimensional Drawings

Dual Section Model 84 Solder Lugs

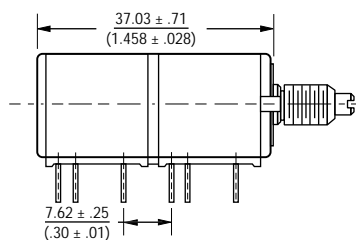

Dual Section Model 83 PC Pins

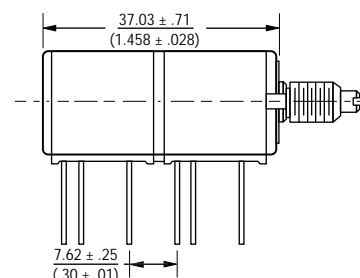

Note: The Models 83/84 dimensions for dual section assembly are for either single or dual concentric shaft styles.

DIMENSIONS ARE: $\frac{\text{METRIC}}{\text{(INCHES)}}$

For dimensional drawings see page 220 and 223.
For ordering information see page 2221

NOTE: MODEL 83/84 PERFORMANCE SPECIFICATIONS DO NOT APPLY TO UNITS SUBJECTED TO PRINTED CIRCUIT BOARD CLEANING PROCEDURES.

¹AT ROOM AMBIENT: +25°C NOMINAL AND 50% RELATIVE HUMIDITY NOMINAL EXCEPT AS NOTED

83/84 - Dimensions and Tolerances



PC Pin Model 83

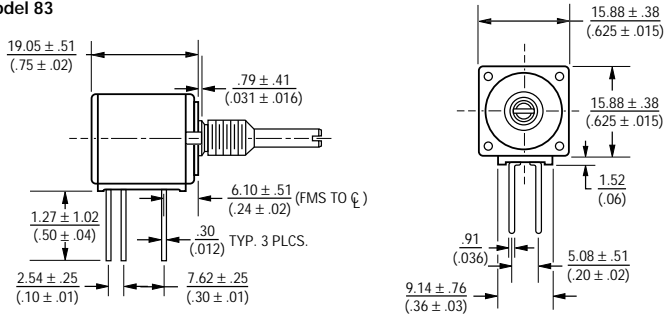

Solder Lug Model 84

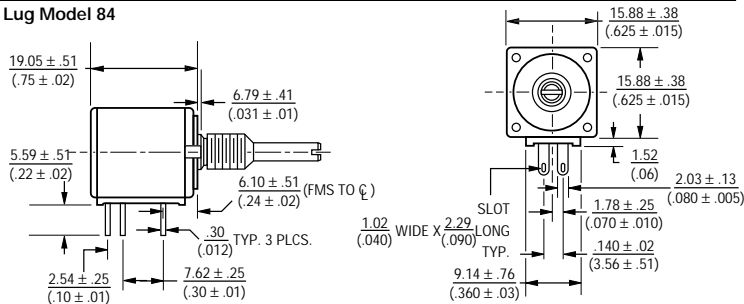

"C" Bushing 1/4" (6.35mm) Dia. Plain - Single Shaft

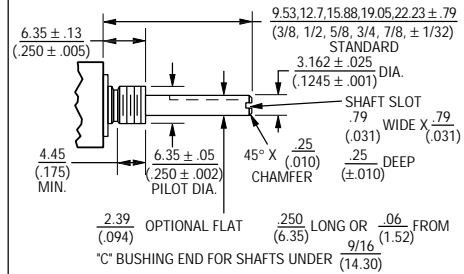

"E" Bushing 1/4" (6.35mm) Dia. Locking - Single Shaft

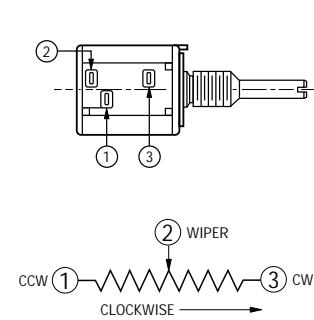
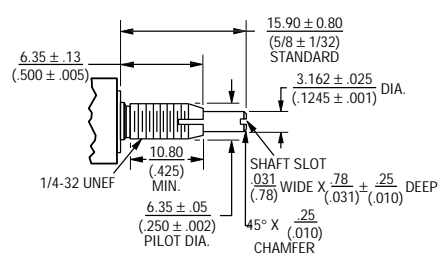

Shaft Flat Orientation

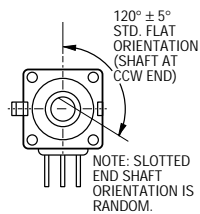

"A" Bushing 3/8" (9.53mm) Dia. Plain - Single Shaft

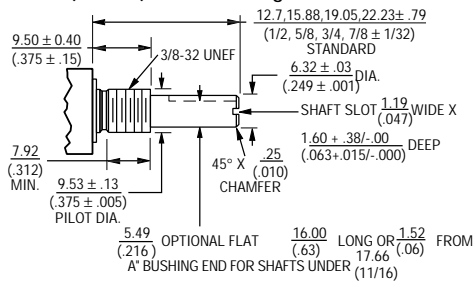

"B" Bushing 3/8" (9.53mm) Dia. Plain - Single Shaft

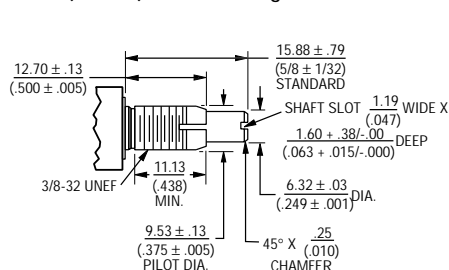

"A" Bushing 3/8" (9.53mm) Dia. Plain - Concentric Shaft

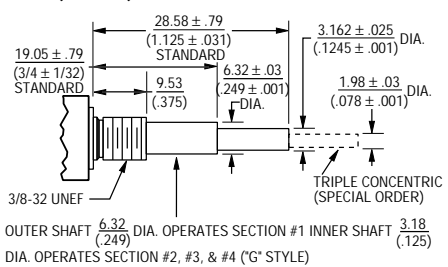

"C" Bushing 1/4" (6.35mm) Dia. Plain - Concentric Shaft

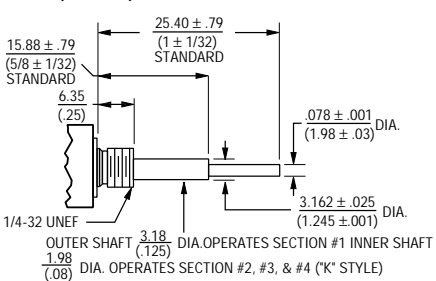

Locating Lug Options - All Model 80 Series

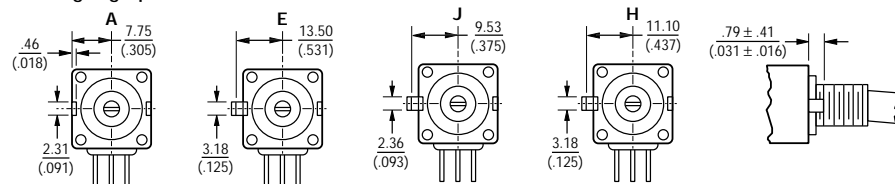

TOLERANCES EXCEPT AS SHOWN: DECIMALS .XXX ± .127 (.005)

.XX ± .38 (.015)

ANGLE ± 5°
FRACTIONS ± 1/64

DIMENSIONS ARE: METRIC (INCHES)

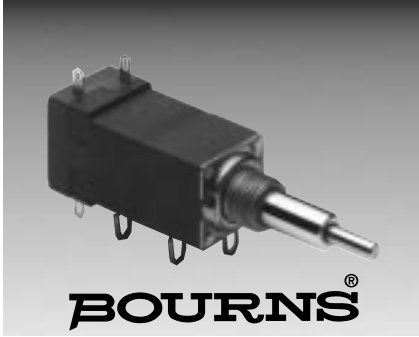

Features

- Designed for “on-off” function control
- Positive action, “non-tease” detent
- Low actuation torque

85/86 - 5/8" Square Single-Turn Rotary Switch

Initial Electrical Characteristics¹

Contacts:	
DPST	N.O./N.O., N.C./N.C. or N.O./N.C.
DPDT	2 N.O./N.C. (break before make)
Power Rating (Resistive Load):	
DPST	2A @ 125 volts RMS-60 Hz or 2A @ 28 VDC, 1A@ 250 volts RMS-60 Hz
DPDT	1A @ 125 volts RMS-60 Hz or 1A @ 28 VDC
Contact Resistance (.1VDC-10mA)	10 milliohms nominal
Contact Bounce5 milliseconds maximum
Dielectric Withstanding Voltage	MIL-STD-202, Method 301
Sea Level	1500 VAC minimum
Insulation Resistance	1000 megohms minimum

Environmental Characteristics¹

Operating Temperature Range	0°C to +70°C
Storage Temperature Range	-65° to +125°C
Vibration (Dual Section)	8G
Contact Resistance	10 milliohms maximum
Contact Bounce	0.1 millisecond maximum
Shock (Dual Section)	20G
Contact Resistance	10 milliohms maximum
Contact Bounce	0.1 millisecond maximum
Rotational Life	25,000 cycles
Switch Actuating Torque (50% Duty cycle @ Rated Power Load)2 to 7 oz.-in. (1.41 to 4.94 Ncm)
Contact Resistance	100 milliohms maximum
Moisture Resistance	MIL-STD-202, Method 106, Condition B
Contact Resistance (0.1VDC-10mA)	10 milliohms maximum
Insulation Resistance (After 24 Hours @ Room Temperature) (500 VDC)	100 megohms minimum
Switch Housing Material	High temperature, flame retardant, thermosetting plastic

Mechanical Characteristics¹

Actuating Torque (Each Section, Switch Module Only)5 to 15 oz.-in. (3.53 to 10.6 Ncm)
Running Torque (Out of Detent, 2-4 Module Assembly)	0.3 to 2 oz.-in. (0.21 to 1.41 Ncm)
Detent	CW or CCW standard
Actuation Angle	25°
Contact Materials	Fine silver with gold overlay
Terminal Styles	Solder lug only
Standard Orientation	In-line with control terminals
Optional	Rotated 90° CCW from standard
Terminal Strength (Before and After Soldering Heat Exposure)	2 lbs. (0.9 Kg) minimum

NOTE: MODEL 85/86 PERFORMANCE SPECIFICATIONS DO NOT APPLY TO UNITS SUBJECTED TO PRINTED CIRCUIT BOARD CLEANING PROCEDURES.

¹AT ROOM AMBIENT: +25°C NOMINAL AND 50% RELATIVE HUMIDITY NOMINAL, EXCEPT AS NOTED.

Model 81, 82 - Dimensions and Tolerances

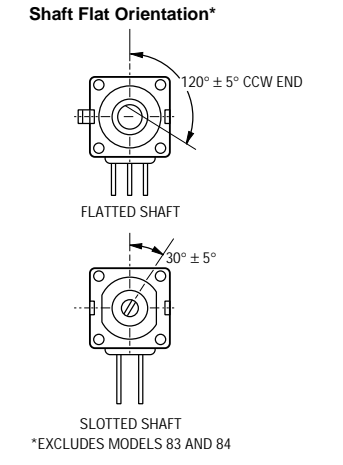
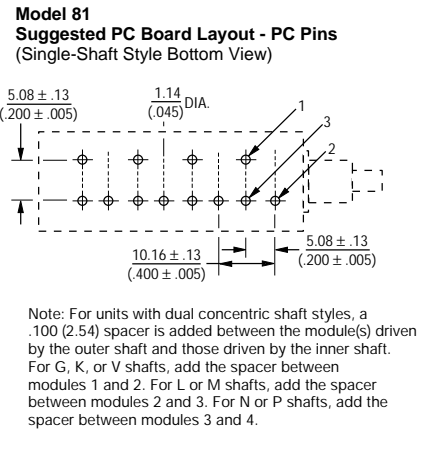
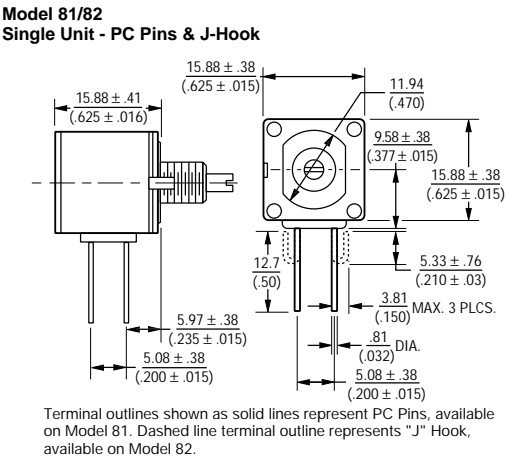
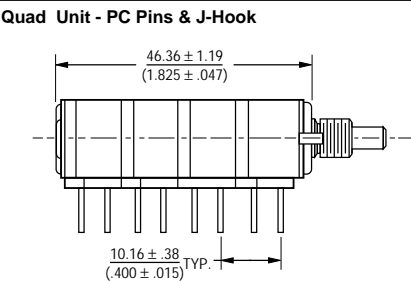
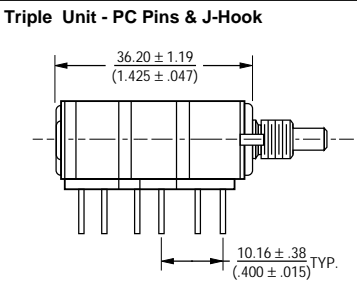
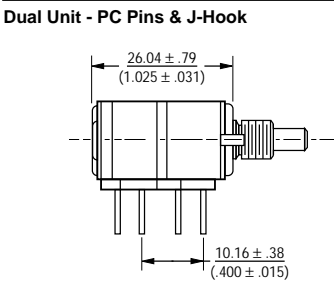
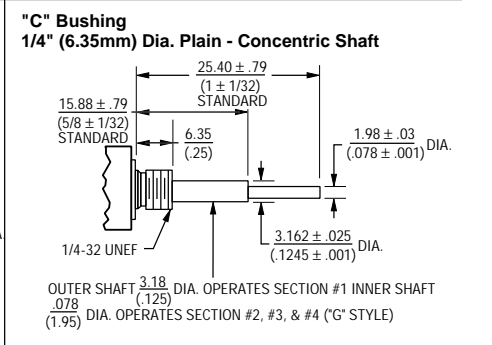
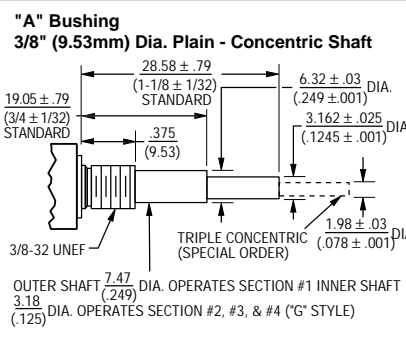
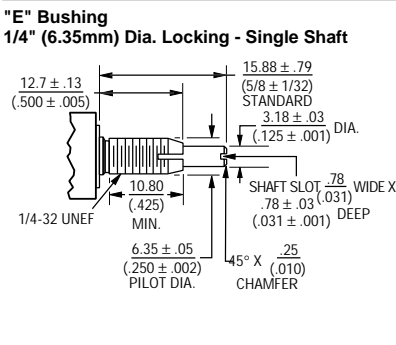
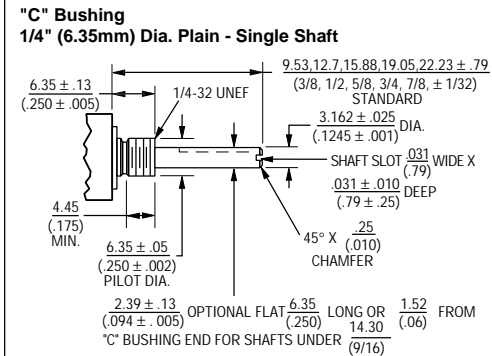
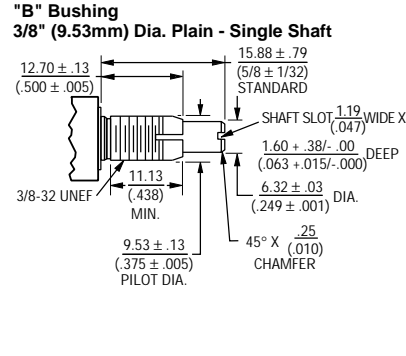
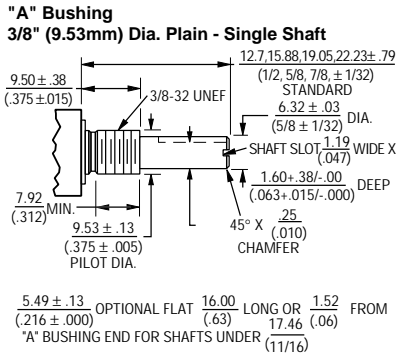

Model 83, 84, 85, 86 - Dimensions and Tolerances



Solder Lug Model 84

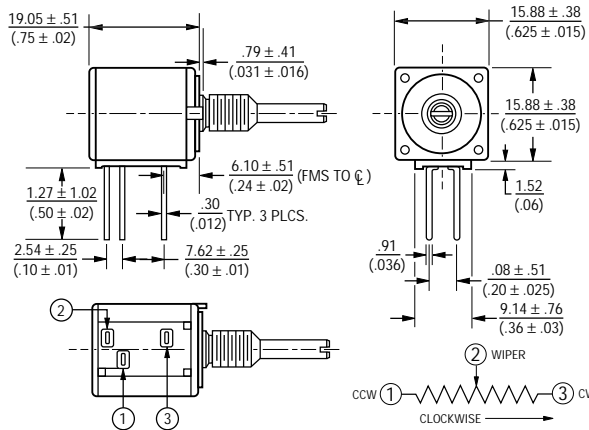

Solder Lug Model 84

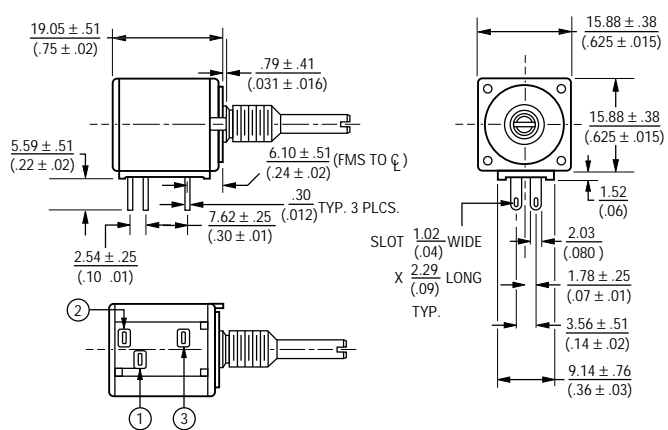

Primary Potentiometer Module Model 85/86

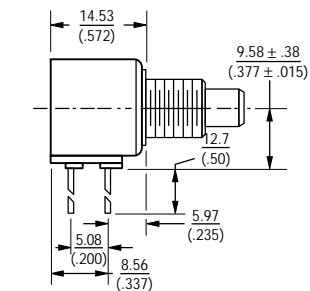

Secondary Potentiometer Module Model 85/86

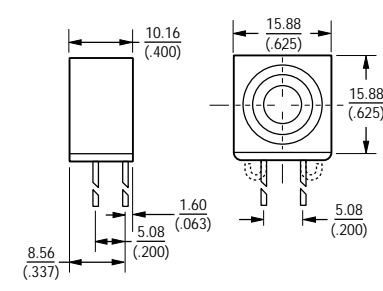

Dual Section Model 83 PC Pins

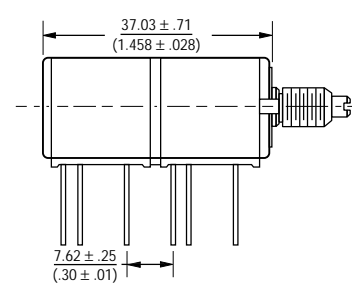

Switch Module Model 85/86

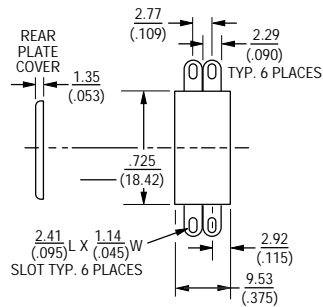

Assembly Sequence Model 85/86 Secondary Potentiometer Module

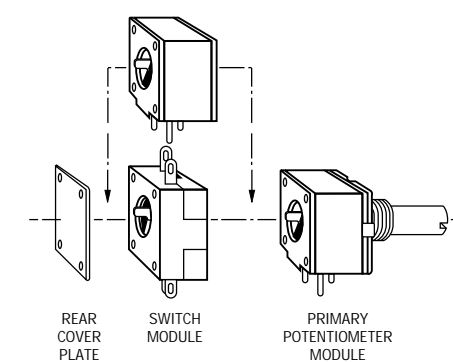

Dual Section Model 84 Solder Lugs

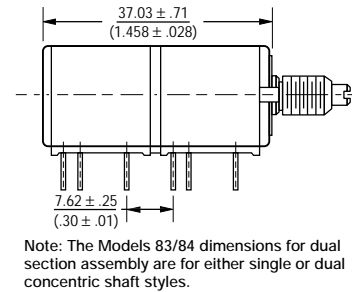

Note: The Models 83/84 dimensions for dual section assembly are for either single or dual concentric shaft styles.

TOLERANCES EXCEPT AS SHOWN: DECIMAL .XXX ± $\frac{127}{.005}$
 .XX ± $\frac{38}{.015}$
 ANGLE ± 5%

Locating Lug Options - All Model 80 Series

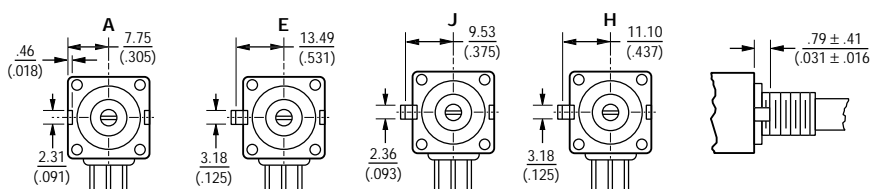

E = $2.36 \pm .76$ (.093 ± .03) H & J = $1.98 \pm .41$ (.078 ± .016)

DIMENSIONS ARE: METRIC (INCHES)

How To Order 80 Series Panel Controls

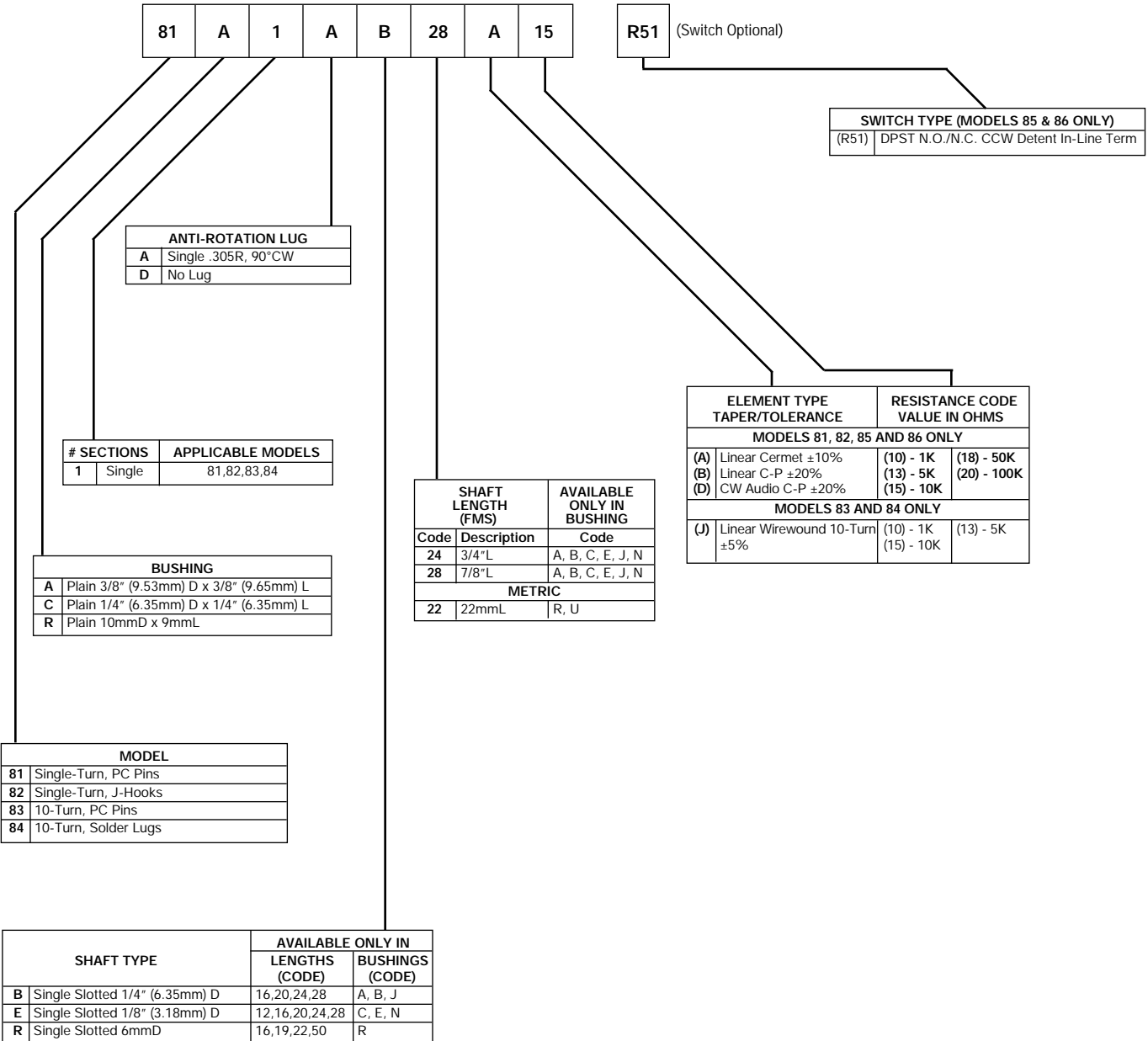



Features

- Features one-piece molded plastic
- Available in a variety of pin-out shaft and rotor assemblies configurations
- Virtually infinite electrical circuit
- Model 96 sealed for board wash
- Metal shaft available as special feature

91, 93, 95, 96 - 5/8" Square Single-Turn

Initial Electrical Characteristics ¹	Conductive Plastic Element	Cermet Element
Standard Resistance Range		
Linear Tapers (A, B, E, & H)	(B & E) 1K ohms to 1 megohm	(A & H) 50 ohms to 1 megohm
Audio Tapers (C, D, F, G, S, & T)	(D, G, S, & T) 1K ohms to 1 megohm	(C & F) 1K ohms to 1 megohm
Resistance Tolerance	(B, D, & G tapers) ±20% (E, S, & T tapers) ±10%	(A, C, & F tapers) ±10% (H taper) ±5%
Independent Linearity	(B & E tapers) ±5%	(A & H tapers) ±5%
Absolute Minimum Resistance	2 ohms maximum	2 ohms maximum
Continuity	Maintained for full mechanical angle	Maintained for full mechanical angle
Effective Electrical Angle	240° ±5°	240° ±6°
Contact Resistance Variation	±1%	±1% or 3 ohms (whichever is greater)
Dielectric Withstanding Voltage	MIL-STD-202, Method 301	MIL-STD-202, Method 301
Sea Level	1,500 VAC minimum	1,500 VAC minimum
70,000 Feet	500 VAC minimum	500 VAC minimum
Insulation Resistance (500 VDC)	1,000 megohms minimum	1,000 megohms minimum
Power Rating (Voltage Limited By Power Dissipation or 350 VAC, Whichever Is Less)		
+70°C Single Section Assembly	(B & E tapers) 0.5 watt (D, G, S, & T tapers) 0.25 watt	(A & H tapers) 2 watts (C & F tapers) 1 watt
+70°C Multiple Section Assembly	(B & E tapers) 0.5 watt/section (D, G, S, & T tapers) 0.25 watt/section	(A & H tapers) 1 watt/section (C & F tapers) 0.5 watt/section
+125°C	0 watt	0 watt
Roll-on/Roll-off	(B & E tapers) 0.25% maximum (D & S tapers) 0.1% maximum CCW end (G & T tapers) 0.1% maximum CW end (D & S tapers) 0.5% maximum CW end (G & T tapers) 0.5% maximum CCW end	(A & H tapers) 0.5% maximum (C taper) 0.1% maximum CCW end (F taper) 0.1% maximum CW end (C taper) 1.0% maximum CW end (F taper) 1.0% maximum CCW end
Theoretical Resolution	Essentially infinite	Essentially infinite
Environmental Characteristics¹		
Operating Temperature	+1°C to +125°C	+1°C to +125°C
Storage Temperature Range	-55°C to +125°C	-55°C to +125°C
Temperature Coefficient		
Over Storage Temperature Range	±1,000PPM/°C	±150PPM/°C
Vibration (Single Section)	15G	15G
Total Resistance Shift	±2% maximum	±2% maximum
Voltage Ratio Shift	±5% maximum	±5% maximum
Shock (Single Section)	30G	30G
Total Resistance Shift	±2% maximum	±2% maximum
Voltage Ratio Shift	±5% maximum	±5% maximum
Load Life	1,000 hours	1,000 hours
Total Resistance Shift	±10% maximum	±5% maximum
Rotational Life (No Load)	100,000 cycles	100,000 cycles
Total Resistance Shift	(B & E tapers) 10 ohms or ±15% maximum (whichever is greater)	10 ohms or ±10% maximum (whichever is greater)
Total Resistance Shift	(D, G, S, & T tapers) ±20% maximum	
Contact Resistance Variation @ 50,000 cycles	(B & E tapers) ±2% (D, G, S, & T tapers) ±3%	
Moisture Resistance	MIL-STD-202, Method 103, Condition B	MIL-STD-202, Method 103, Condition B
Total Resistance Shift	(B & E tapers) ±10% maximum (D, G, S, & T tapers) ±20% maximum	(All tapers) ±5% maximum
Insulation Resistance (500 VDC)	100 megohms minimum	100 megohms minimum
Mechanical Characteristics¹		
Running Torque		
Single or Dual Section (A, D & r Bushings)	0.3 to 1.5 oz.-in. (0.21 to 1.06 Ncm)	0.3 to 1.5 oz.-in. (0.21 to 1.06 Ncm)
Single or Dual Section (C & U Bushings)	0.2 to 1.5 oz.-in. (0.14 to 1.06 Ncm)	0.2 to 1.5 oz.-in. (0.14 to 1.06 Ncm)
Starting Torque	0.3 maximum above average running torque	0.3 maximum above average running torque
Torque Variation	0.5 oz.-in. (0.35 Ncm) max. in 45° shaft travel	0.5 oz.-in. (0.35 Ncm) max. in 45° shaft travel
Stop Strength (1/8" D shaft)	4 in.-lb. (45.19 Ncm)	4 in.-lb. (45.19 Ncm)
(1/8" D shaft)	3 in.-lb. (33.89 Ncm)	3 in.-lb. (33.89 Ncm)
Mechanical Angle	300° ±5°	300° ±5°
Weight (Single Section)	7 grams maximum	7 grams maximum
Each Additional Section	4 grams maximum	4 grams maximum
Terminals	Printed circuit terminals, J-Hooks or solder lugs	Printed circuit terminals, J-Hooks or solder lugs
Marking	Manufacturer's trademark, date code, resistance, manufacturer's part number	Manufacturer's trademark, date code, resistance, manufacturer's part number

FOR DIMENSIONAL DRAWINGS SEE PAGE 226.

FOR ORDERING INFORMATION SEE PAGE 227.

NOTE: ALL MODEL 90 PERFORMANCE SPECIFICATIONS DO NOT APPLY TO UNITS SUBJECTED TO PRINTED CIRCUIT BOARD CLEANING PROCEDURES, EXCEPT FOR THE SEALED (MODEL 96).

¹AT ROOM AMBIENT: +25°C NOMINAL AND 50% RELATIVE HUMIDITY NOMINAL EXCEPT AS NOTED

91, 93, 95, 96 Dimensions and Tolerances



Model 91 PC Pin Terminals, In-Line

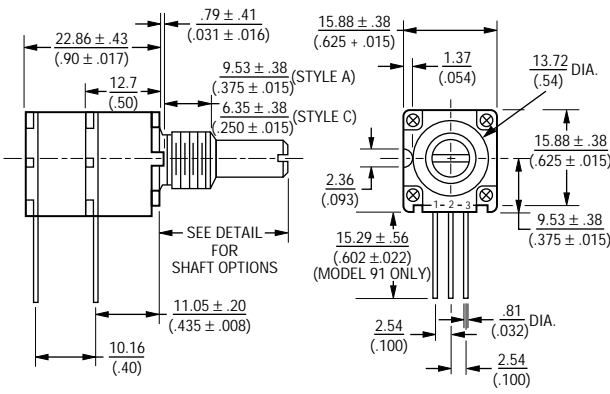

Model 95 Solder Lug Terminals, "Triangular" Pattern

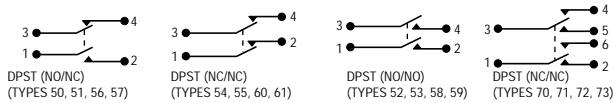
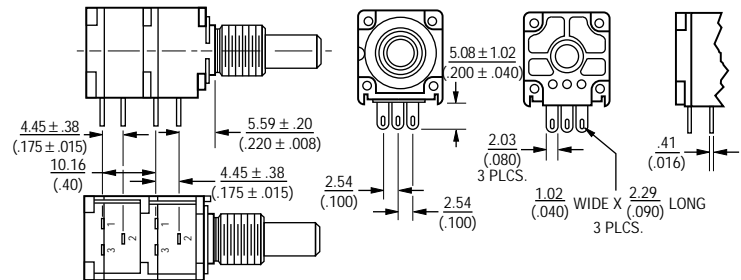

Switch contacts shown in detent position.

Model 93 PC Pin Terminals, "L" Pattern

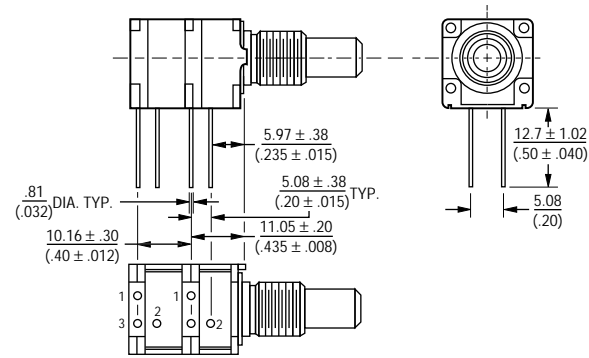

Bushing Styles

- 3/8 THREADLESS (9.53mm) (STYLE "D")
- 3/8-32 UNEF (9.53mm) (STYLE "A")
- 1/4-32 UNEF (6.35mm) (STYLE "C")
- M10 X 0.75-6g (STYLE "R")
- M7 X 0.75-6g (STYLE "U")

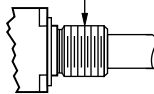

Shaft Styles

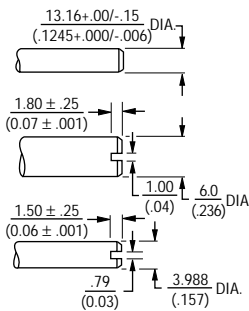
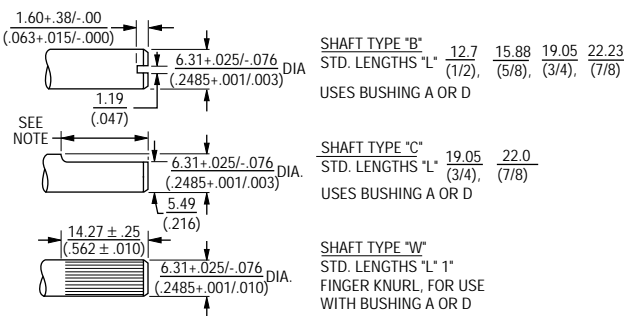

SHAFT TYPE "D"
STD. LENGTHS "L" 12.7 (1/2), 15.88 (5/8), 19.05 (3/4) USES BUSHING C

SHAFT TYPE "R"
STD. LENGTHS "L" 16.0 (5/8), 19.05 (3/4), 22.0 (7/8) USES BUSHING R

SHAFT TYPE "T"
STD. LENGTHS "L" 12.0 (1/2), 16.0 (5/8), 22.0 (7/8) USES BUSHING U

NOTE: FOR 19.05 (750) SHAFT - FLAT LENGTH IS 7.95 (.313)
FOR 22.23 (875) SHAFT - FLAT LENGTH IS 11.18 (.440)

*DIMENSIONS ARE IN MM

TOLERANCES EXCEPT AS SHOWN: DECIMAL .XXX ± $\frac{.128}{(.015)}$ FRACTION ± 1/64
.XX ± $\frac{.005}{(.38)}$ ANGLE ± 5°

DIMENSIONS ARE: $\frac{\text{METRIC}}{\text{(INCHES)}}$

90 Series Panel Controls Dimensions and Tolerances **BOURNS®**

How To Order

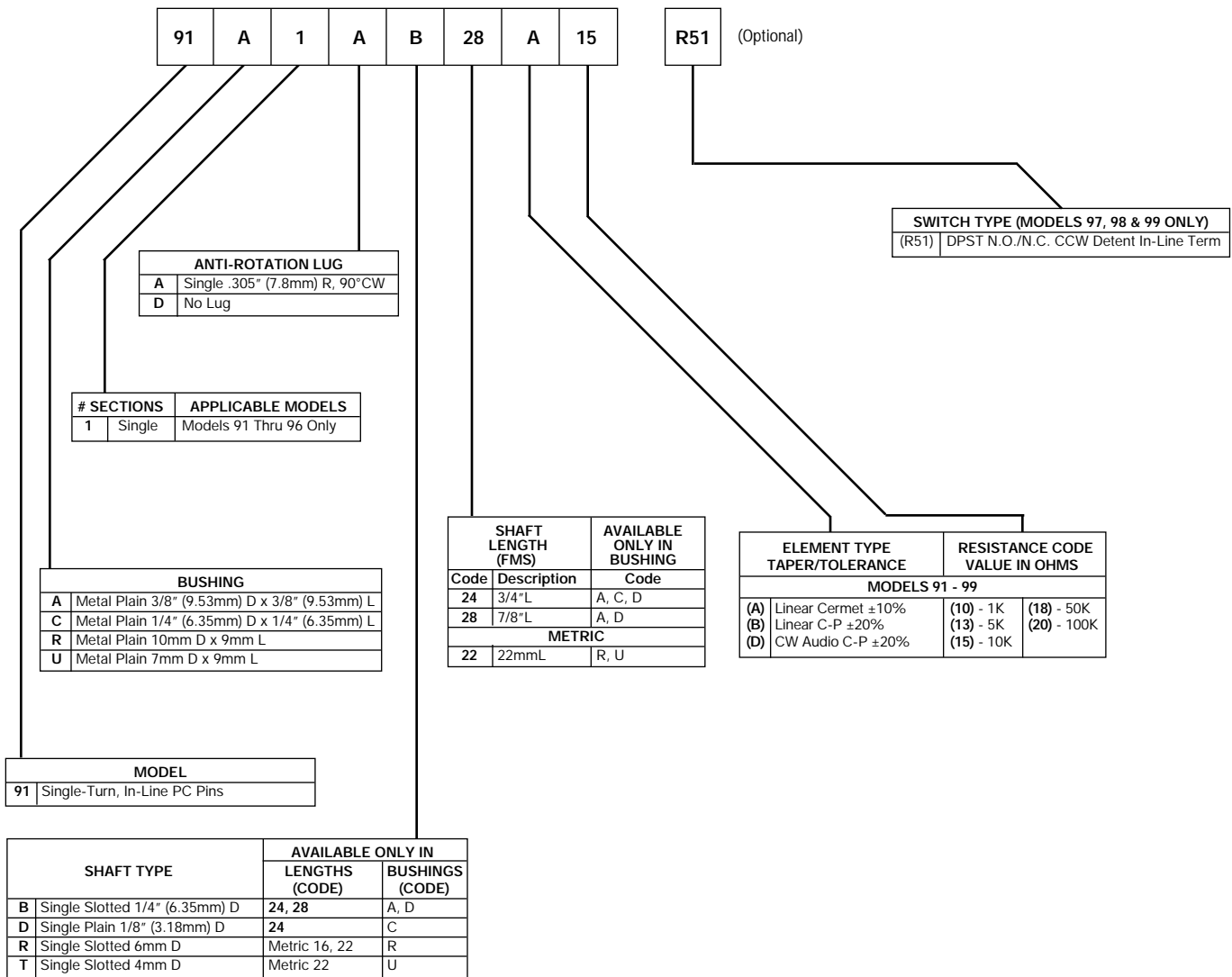

Recommended part numbers.
For other options contact the factory.
Boldface listings are in stock and readily available through distribution.



Features

- Single-turn (3851 and 3852)
- Linear and audio tapers
- 3-3/4-turn (3856)
- Wide resistance range
- Minimal depth package
- Good resolution

3851/3852/3856 - 3/4" Diameter Panel Control

Initial Electrical Characteristics¹

	3851 Conductive Plastic Element	3852/3856 Cermet Element
Standard Resistance Range		
Linear Tapers (A, B, E, and H)	1K to 1 megohm	100 ohms to 1 megohm
Audio Tapers (C, D, F, and G)	1K to 1 megohm	1K ohms to 1 megohm
Resistance Tolerance	±20%	±10%
Zero Base Linearity	(B, D, & G tapers) ±20% (E taper) ±10%	(A, C, & F tapers) ±10% (H taper) ±5%
Independent Linearity	±10%	(A & H tapers) ±5%
Absolute Minimum Resistance	2 ohms maximum	2 ohms maximum
Continuity	Maintained for full mechanical angle	Maintained for full mechanical angle
Effective Electrical Angle	250° ±5°	250° ±5°
Contact Resistance Variation	±1%	±3% of total resistance or 3 ohms (whichever is greater)
Dielectric Withstanding Voltage	MIL-STD-202, Method 301	MIL-STD-202, Method 301
Sea Level	900 VAC minimum	900 VAC minimum
70,000 Feet	350 VAC minimum	350 VAC minimum
Insulation Resistance (500 VDC)	1,000 megohms minimum	1,000 megohms minimum
Power Rating (Voltage Limited By Power Dissipation or 316 VAC, Whichever Is Less)		
+70°C	(B & E tapers) 1 watt (D & G tapers) 0.5 watt	(A & H tapers) 2 watts (C & F tapers) 1 watt
+125°C	0 watt	0 watt
+150°C		0 watt
Theoretical Resolution	Essentially infinite	Essentially infinite

Environmental Characteristics¹

Operating Temperature	-1°C to +125°C
Storage Temperature Range	-65°C to +125°C
Temperature Coefficient	
Over Storage Temperature Range	±1,000PPM/°C
Vibration	20G
Total Resistance Shift	±2% maximum
Voltage Ratio Shift	±5% maximum
Shock	100G
Total Resistance Shift	±2% maximum
Voltage Ratio Shift	±5% maximum
Load Life	1,000 hours
Total Resistance Shift	±10% maximum
Rotational Life (No Load)	100,000 cycles
Total Resistance Shift	±15% maximum
Moisture Resistance	MIL-STD-202, Method 103, Condition B
Total Resistance Shift	±10% maximum
Insulation Resistance (500 VDC)	100 megohms minimum

Mechanical Characteristics¹

Shaft Torque	(A & B bushings) .05 to 6.0 oz.-in. (0.35 to 4.23 Ncm)	3852 (A & B bushings) 0.5 to 6.0 oz.-in. (0.35 to 4.23 Ncm)
	(C & E bushings) 0.3 to 6.0 oz.-in. (0.21 to 4.23 Ncm)	(C & E bushings) 0.3 to 6.0 oz.-in. (0.21 to 4.23 Ncm)
		3856 — 0.15 to 3.0 oz.-in. (0.11 to 2.12 Ncm)
Stop Strength	5 in.-lb. (56.5 Ncm)	5 in.-lb. (56.5 Ncm)
Mechanical Angle	280° ±5°	3852 — 280° ±5° 3856 — 1350° ±50°
Weight	30 grams maximum	30 grams maximum
Terminals	Printed circuit terminals or solder lugs	Printed circuit terminals or solder lugs
Marking	Manufacturer's trademark, wiring diagram, date code, resistance, manufacturer's part number	Manufacturer's trademark, wiring diagram, date code, resistance, manufacturer's part number

FOR ORDERING INFORMATION SEE PAGE 229.

¹AT ROOM AMBIENT: +25°C NOMINAL AND 50% RELATIVE HUMIDITY NOMINAL, EXCEPT AS NOTED.

3851/3852/3856 Dimensions and Tolerances



3851A/3852A

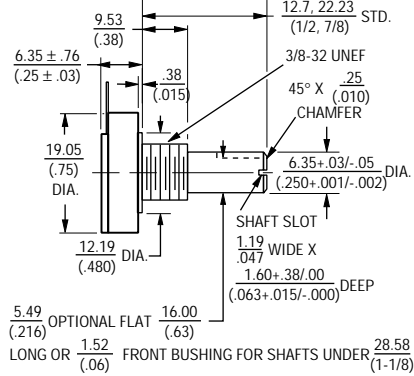

3851B/3852B

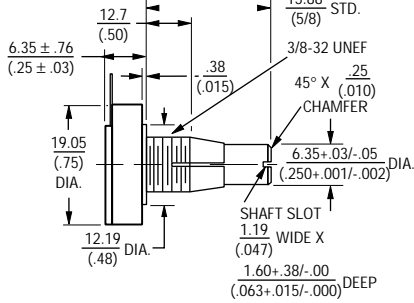

Terminal Configuration

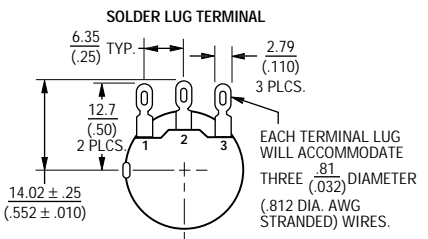

3851C/3852C

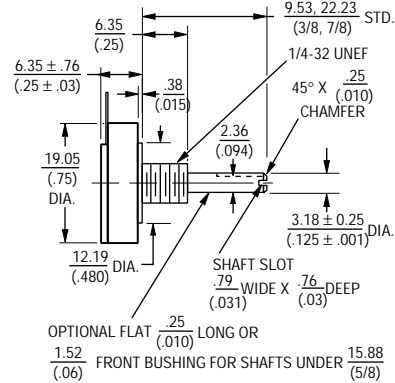

3851E/3852E

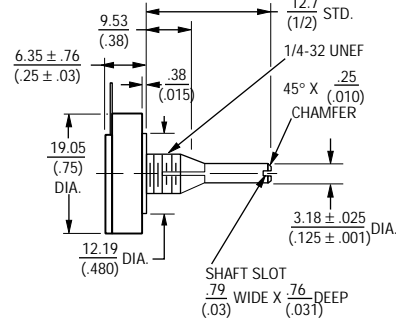

3851/3852/3856

A, B & H BUSHINGS

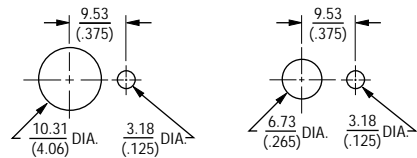

3856A

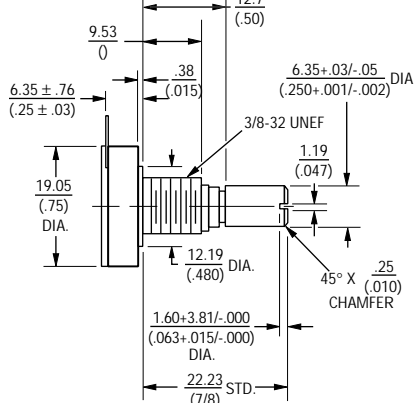

3856H

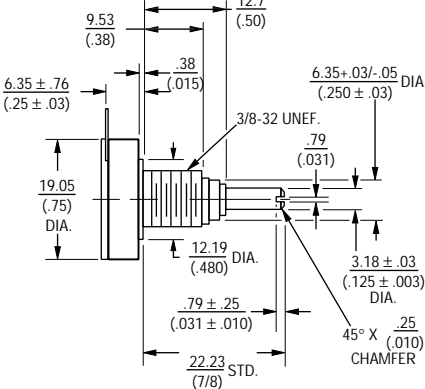

Shaft End Detail 3850 Family

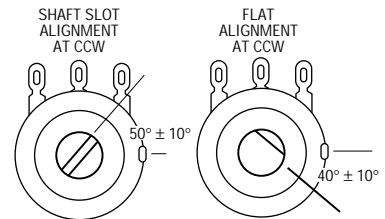

TOLERANCES EXCEPT AS NOTED:
 DECIMALS: .XXX \pm .127 (.005), XX \pm .38 (.015)
 FRACTIONS: \pm 1/64
 ANGLE: \pm 3%

DIMENSIONS ARE: METRIC (INCHES)



Features

- Small diameter
- Wide resistance range
- Good resolution
- Linear tapers

BOURNS®

3862 - 1/2" Diameter Single-Turn Panel Control

Initial Electrical Characteristics¹

Standard resistance Range (A & H Tapers).....	100 ohm to 5 megohms
Resistance Tolerance	(A Taper) ±10% (H Taper) ±5%
Independent Linearity	±5%
Absolute Minimum Resistance	2 ohms maximum
Continuity	Maintained for full mechanical angle
Effective Electrical Angle	260° ±10°
Contact Resistance Variation	±3% of total resistance
Theoretical Resolution	Essentially infinite
Dielectric Withstanding Voltage	MIL-STD-202, Method 301
Sea Level	750 VAC minimum
70,000 Feet	350 VAC minimum
Insulation Resistance (500 VDC)	1,000 megohms minimum
Power Rating (Voltage Limited by Power Dissipation or 350 VAC, Whichever is Less)	
+70°C	1 watt
+125°C	0 watt

Environmental Characteristics¹

Operating Temperature	-1°C to +125°C
Storage Temperature Range	-65°C to +125°C
Temperature Coefficient Over Temperature Range	±150 ppm/°C
Vibration	20G
Total Resistance Shift	±2% maximum
Voltage Ratio Shift	±6% maximum
Shock	50G
Total Resistance Shift	±2% maximum
Voltage Ratio Shift	±6% maximum
Load Life	1,000 hours
Total Resistance Shift	±3% maximum
Rotational Life (C & N Bushing) (No Load)	50,000 cycles
Total Resistance Shift	±5% maximum
Moisture Resistance	MIL-STD-202, Method 106, Condition B
Total Resistance Shift	±2% maximum
Insulation Resistance (500 VDC)	100 megohms minimum
Salt Spray	MIL-STD-202, Method 101, Condition A

Mechanical Characteristics¹

Shaft Torque	5 oz.-in. (3.53 Ncm) maximum
Shaft Locking Torque with Locking Bushings	20 oz.-in. (14.12 Ncm)
Mechanical Angle	295° ±3°
Weight	25 grams maximum
Terminals	Printed circuit pins or J-Hooks
Markings	Mfr's. trademark, wiring diagram, date code, resistance, manufacturer's part number
Stop Strength	3 in.-lb. maximum

PCB LAYOUT

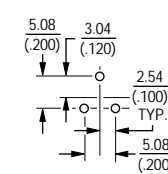

PANEL LAYOUT

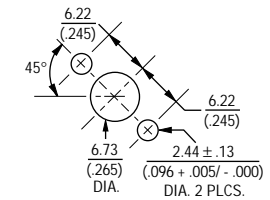

¹AT ROOM AMBIENT: +25°C NOMINAL AND 50% RELATIVE HUMIDITY NOMINAL, EXCEPT AS NOTED.

3862E/T

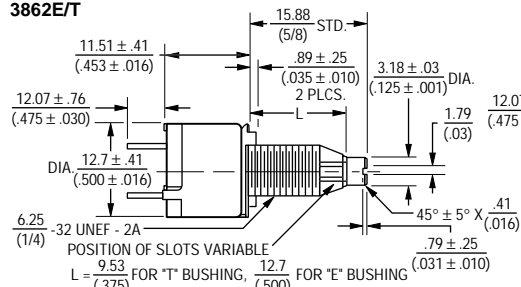

3862C/N

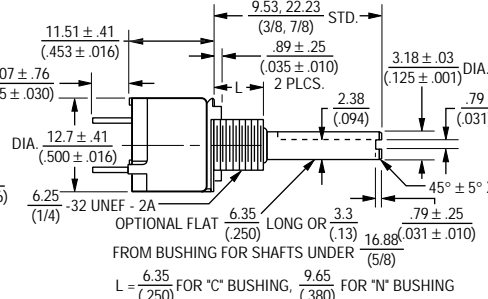

Shaft End Detail 3862

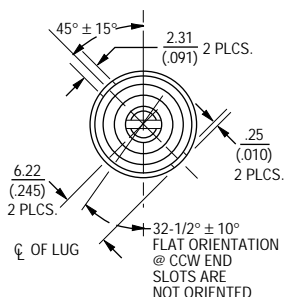

DIMENSIONS ARE: METRIC (INCHES)

3800 Series Dimensions and Tolerances



Dimensional Drawings And Tolerances

PC PIN TERMINAL

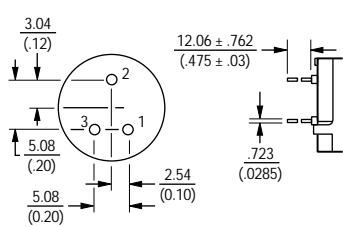

J-HOOK TERMINAL

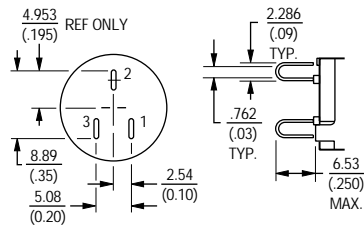

DIMENSIONS ARE: $\frac{\text{METRIC}}{\text{(INCHES)}}$

How To Order

3852 A 28 2 103 A

	SHAFT TYPE (FMS) & DIAMETER	AVAILABLE ONLY IN	
		MODELS	BUSHINGS
12	3/8" (9.53mm) L X 1/8" (3.18mm) D	3851, 3852, 3862	C
16	1/2" (12.7mm) L X 1/8" (3.18mm) D	3851, 3852, 3862	C, E C
20	5/8" (15.88mm) L X 1/4" (6.35mm) D	3851, 3852	A, B
28	7/8" (22.20mm) L X 1/4" (6.35mm) D	3851, 3852, 3856	A, B A

Consult factory for lengths not shown.

BUSHING	APPLICABLE MODELS
A	Plain 3/8" (9.53mm) D x 3/8" (9.53mm) L
C	Plain 1/4" (6.35mm) D x 1/4" (6.35mm) L

RESISTANCE CODE/VALUE (IN OHMS)	
Models 3851, 3852, 3856, 3862	
(102)	1K
(502)	5K
(103)	10K
(503)	50K
(104)	100K

MODEL	
3852	3/4" (19.05mm) D Single-Turn Cermet
3862	1/2" (12.7mm) D Single-Turn Cermet

TERMINAL STYLE AND SHAFT TYPE	
2	Solder Lugs*, Slotted End
6	PC Pins, Slotted End

*Model 3862 comes with J-hook solder lugs.

ELEMENT TAPER/TOLERANCE	APPLICABLE MODELS
A	Linear ±10%

*The maximum resistance range for audio tapers is 1000 ohms to 2.5 megohms.



Features

- Minimal installation space for maximum design flexibility
- Linear or audio taper versions
- Wide assortment of options

Open-Frame Slide Potentiometer

Electrical Characteristics

	20MM
Standard Resistance Range.....Linear..... (ohms) Audio.....	2K 5K 10K 20K 50K 100K 200K 500K 5K 10K 20K 50K 100K 200K 500K
Resistance Tolerance	±20%, All Resistance/Tapers
Resistance Taper.....Linear	B Tapers (see taper curves)
Independent Linearity.....	±5% for B Tapers
Absolute Minimum Resistance.....	1% or 100 ohms, whichever is less, for B taper
Continuity	Maintained for full stroke
Effective Electrical Travel.....	90% of Mechanical Travel
Peak Noise (CRV) Linear/Audio.....	2% / 5%
Theoretical Resolution.....	Essentially Infinite
Dielectric Strength (Sea Level)	500 VAC, 1 minute, between Lever and Terminals
Insulation Resistance (500 VDC)	1,000 megohms minimum between Lever and Terminals
Power Rating at 70°C.....Linear	0.1 Watt
(0 Watt at 90°C) Audio.....	0.05 Watt
Maximum Working Voltage.....	Power Dissipation or 350 VAC, whichever is less
Tracking Error (Dual Only).....	4 dB maximum; 0 to -40 dB
Environmental Characteristics	
Storage Temperature.....	-20°C to +90°C
Temperature Coefficient of Resistance	±1,000ppm/°C
Vibration (10 to 55 Hz, 1.5mm).....	Voltage Ratio Change: ±5% maximum. Total Resistance Shift: ±2% maximum
Load Life	(Pre-conditioning: 55°C, 20% RH, 24 ± 4 Hours)
(Rated Power at 25°C for 1,000 Hours).....	Total Resistance Shift: ±10%
Sliding Life	Total Resistance Shift: ±5% = Linear; 2K, 5K, 10k, 20K, 50K,
(No Load - 15,000 Cycles)	±10% = Linear; 100K, 200K, 500K, & Audio; 2K to 500k
Moisture Resistance (96 Hours @ 40°C	Total Resistance Shift: Linear ±12% maximum, Audio ±20% maximum
90-95% RH, Rated Power)	Insulation Resistance: 100 megohms minimum
Soldering Heat (3 Seconds @ 350°C).....	Total Resistance Shift: ±5% maximum
Mechanical Characteristics	
Operating Force	15 to 150 Gr
Stop Strength	1.5 Kg minimum
Stroke	20mm
Terminals	PC Pins (Vertical or Horizontal)
Markings.....	Trademark, date code, taper, and resistance (ex. B10K) and Japan

Slide Potentiometer - Dimensions and Tolerances



TAPER CURVES

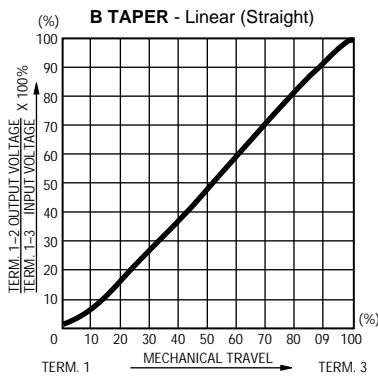

Single Element Vertical Mount

MODEL	DIMENSIONS ± 0.20 (± 0.5)			
	L (STROKE)	A	B	C
SSVA30XXXXXX	1.81 (30)	1.969 (50)	1.535 (39)	1.953 (49.6)
SSVA20XXXXXX	.787 (20)	1.575 (40)	1.142 (29)	1.559 (39.6)
SSVA15XXXXXX	.591 (15)	1.378 (35)	.945 (24)	1.362 (34.6)
SSVA10XXXXXX	.394 (10)	1.181 (30)	.748 (19)	1.165 (29.6)

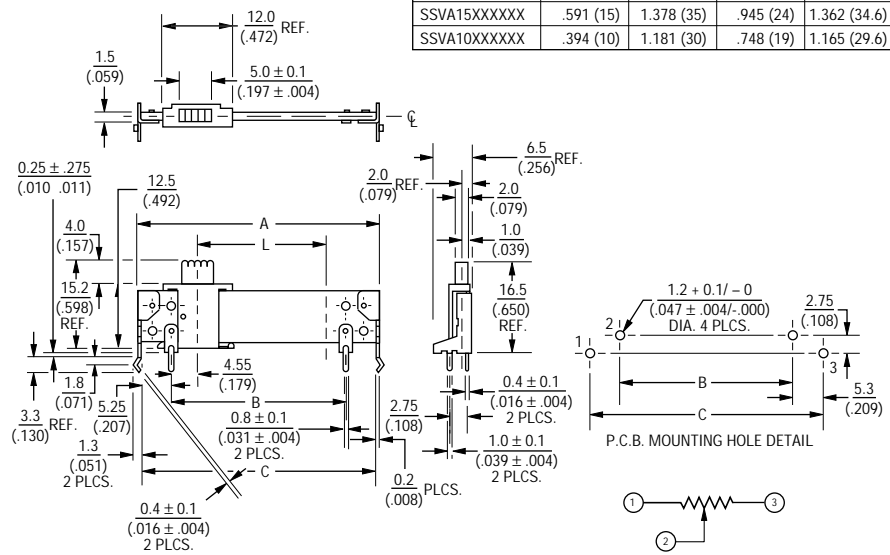

Single Element Horizontal Mount

MODEL	DIMENSIONS ± 0.20 (± 0.5)		
	L (STROKE)	A	B
SSHA30XXXXXX	1.81 (30)	1.535 (39)	1.929 (49)
SSHA20XXXXXX	.787 (20)	1.142 (29)	1.535 (39)
SSHA15XXXXXX	.591 (15)	.945 (24)	1.339 (34)
SSHA10XXXXXX	.394 (10)	.748 (19)	1.142 (29)

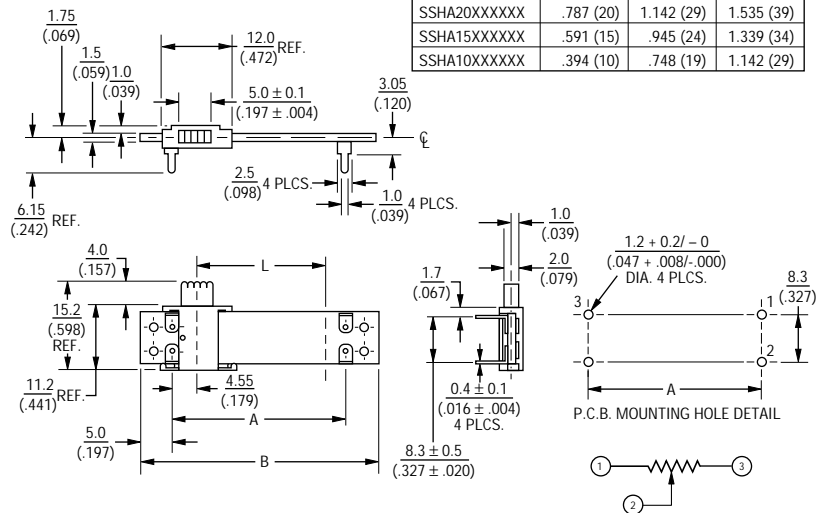

Non-stock adjustable

DIMENSIONS ARE: $\frac{\text{METRIC}}{\text{(INCHES)}}$

Slide Potentiometers - How to Order



S S V A 2 0 B 1 0 3 0 0

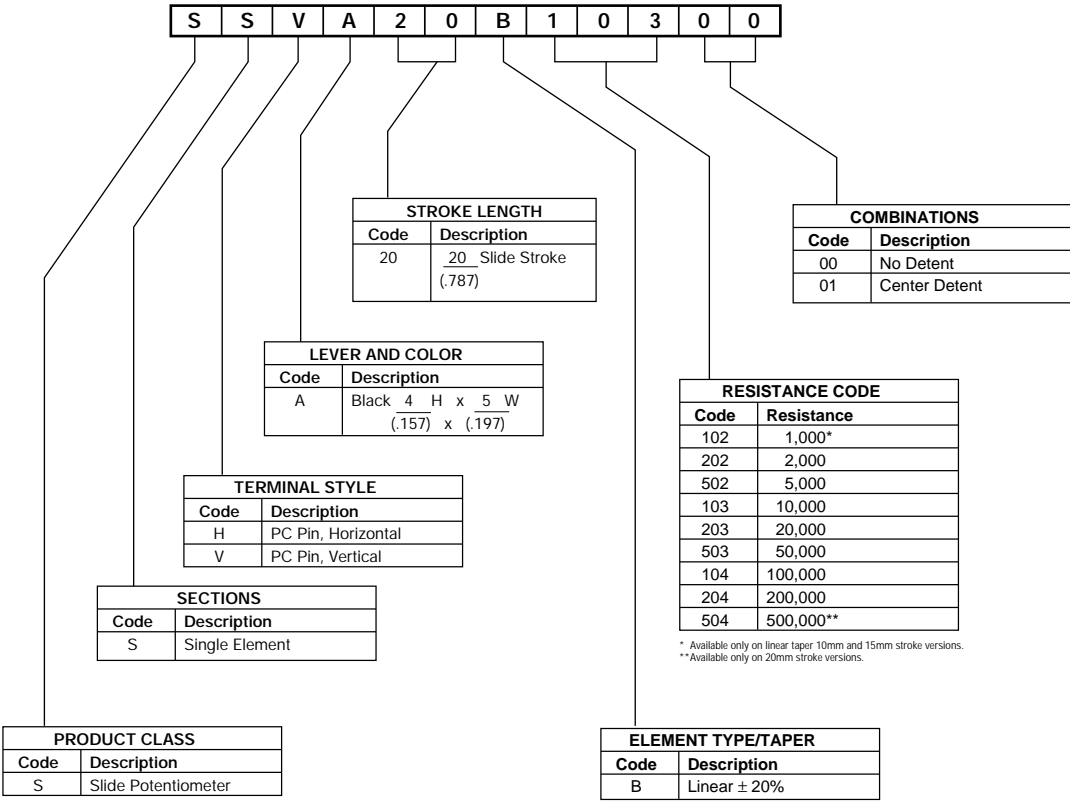

PRODUCT CLASS	
Code	Description
S	Slide Potentiometer

SECTIONS	
Code	Description
S	Single Element

TERMINAL STYLE	
Code	Description
H	PC Pin, Horizontal
V	PC Pin, Vertical

LEVER AND COLOR	
Code	Description
A	Black 4 H x 5 W (.157) x (.197)

STROKE LENGTH	
Code	Description
20	20 Slide Stroke (.787)

ELEMENT TYPE/TAPER	
Code	Description
B	Linear ± 20%

RESISTANCE CODE	
Code	Resistance
102	1,000*
202	2,000
502	5,000
103	10,000
203	20,000
503	50,000
104	100,000
204	200,000
504	500,000**

* Available only on linear taper 10mm and 15mm stroke versions.
 ** Available only on 20mm stroke versions.

COMBINATIONS	
Code	Description
00	No Detent
01	Center Detent

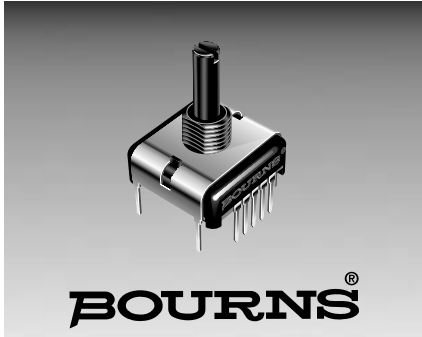

Features

- Space saving design
- Wide range of resistance values
- PC pin or solder lug terminals
- Metric shaft and bushing option
- Mounting brackets available
- Linear or audio taper versions

Slimline Potentiometer

Electrical Characteristics - Potentiometer

Standard Resistance Range	
Linear Tapers500 ohms to 1.5 megohms
Audio Tapers1K ohms to 500K ohms
Resistance Tolerance (All Tapers)±20%
Independent Linearity±5% (linear taper)
Absolute Minimum Resistance5 ohms maximum
Effective Electrical Angle270° ± 5°
Dielectric Withstanding VoltageMIL-STD-202, Method 301
Sea Level1,000 VAC minimum
70,000 Feet500 VAC minimum
Insulation Resistance (500 VDC)1,000 megohms
Power Rating @ 70°C (Voltage Limited by Power Dissipation or 350 VAC, Whichever is Less)	
Linear75 watt
Audio25 watt

Environmental Characteristics

Operating Temperature+1°C to +125°C
Storage Temperature-40°C to +125°C
Load Life (1,000 Hours @ Rated Power, 20% RH, 70°C)±10% maximum resistance shift
Rotational Life50,000 cycles
Total Resistance Shift	
Linear±10 ohms or 12%, whichever is greater
Audio±20% maximum

Mechanical Characteristics

Stop Strength (1/4" and 6mm Shaft Diameters)7 in.-lb. (79.09 Ncm)
Mechanical Angle300° ± 5°
TerminalsPC pin or solder lug
Running Torque0.25 to 1.5 in.-oz. (0.18 to 1.06 Ncm) (undetented)
Mounting Torque7 in.-lbs. (79.09 Ncm) maximum
DetentsCenter, 10, 20, 30, none
Shaft VariationsSee diagram

Product Dimensions

PC PINS (Rear Facing)

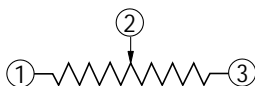
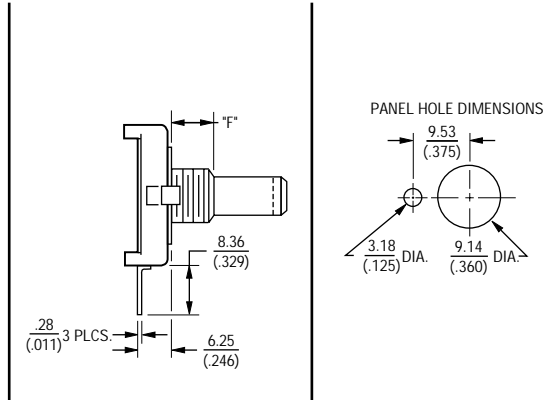
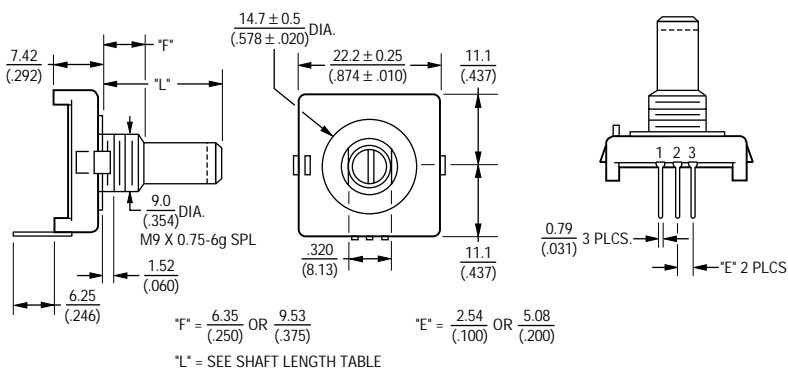

TOLERANCES WHERE NOT SHOWN
 .XX = ±.010
 .XXX = ±.005

DIMENSIONS ARE: $\frac{\text{METRIC}}{\text{(INCHES)}}$

*For lower contact resistance, consult factory.
 For additional features or specifications not shown, consult factory.

Slimline Potentiometers - Dimensions and Tolerances **BOURNS®**

SOLDER LUGS

(Dimensions not given are the same as PC pins (rear facing).)

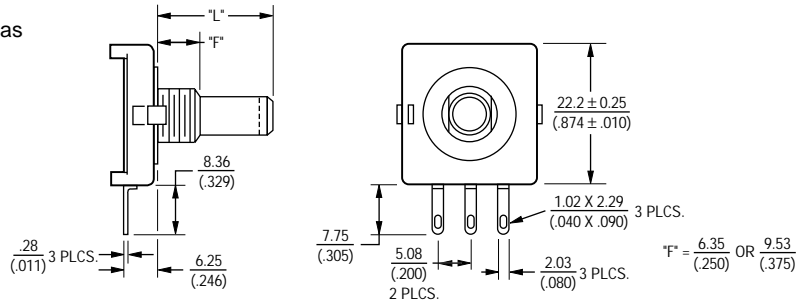

PC PINS (Rear Facing) With Rear Mounting Bracket

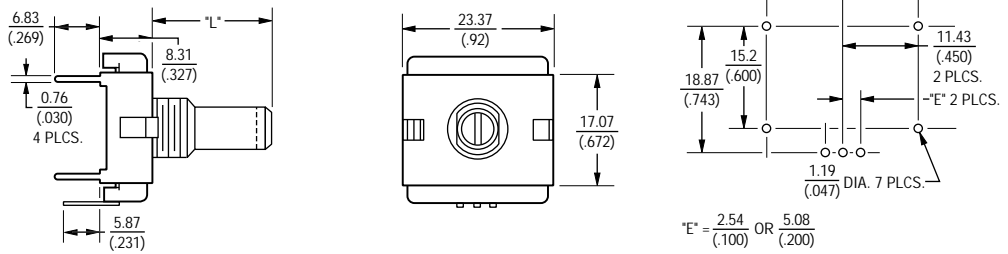

PC PINS (Side Exit) With Side Mounting Bracket

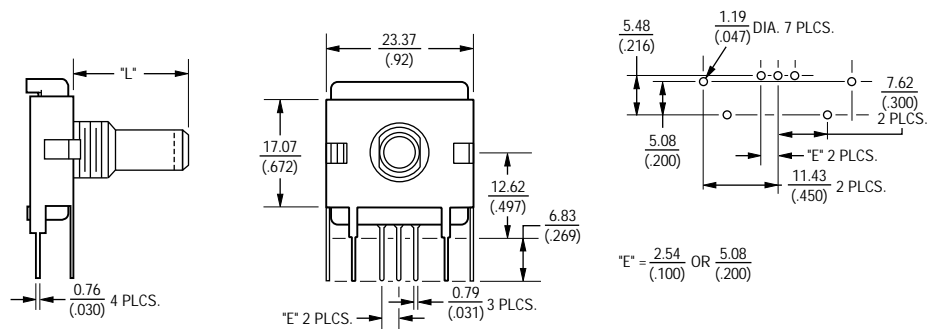

SHAFT STYLES AND ORIENTATION (Full CCW Rotation)

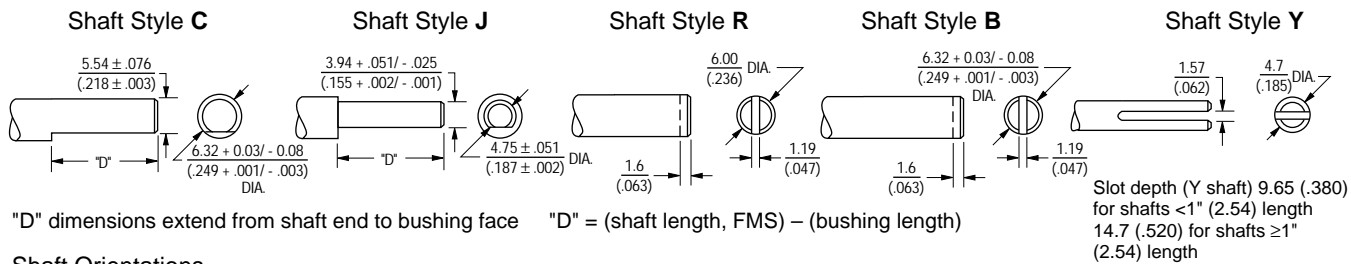

Shaft Orientations

Shaft Styles C, J

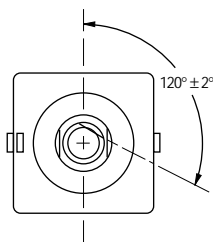

Shaft Styles B, R

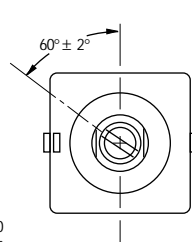

Shaft Style Y

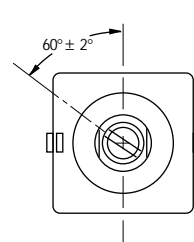

Slimline Potentiometers - How To Order



P C W 1 J - B 2 4 - B A B 1 0 3

SHAFT LENGTH (FMS)		
Code	Description	Available Shaft Styles
24	3/4" (19mm) Length	B, C, J, Y
28	7/8" (22.2mm) Length	B, C, J, Y
Metric		
24	24mm Length	R

RESISTANCE VALUES			
Code	TR	Code	TR
502	5K Ω	103	10K Ω
		503	50K Ω
		104	100K Ω

SHAFT STYLES (See Outline Drawing)	
Code	Description
B	1/4" (6.35mm) Dia. Slotted
C	1/4" (6.35mm) Dia. Flat Head
R	6mm Dia. Slotted (Use Metric Lengths Only)

ELEMENT TAPER VERSIONS	
Code	Taper Description
B	Lin. CP \pm 20%

ANTI-ROTATION LUG	
Code	Description
J	9:00 Position

DETENT CONFIGURATIONS	
Code	Taper Description
A	No Detents

NO. SECTIONS	
Code	Description
1	Single

BUSHING CONFIGURATION		
Code	Description	Available Shaft Styles
W	9mm x .250" (6.35mm) Length Threaded M9 x 0.75 6g 5 Pl	All

HOUSING TERMINAL CONFIGURATION		
Features	Code	
	B	K
Rear Mounting Bracket	X	X
Side Mounting Bracket		
Rear Facing Terminals .100" (2.54mm) Centers	X	X
Side Exiting Terminals .100" (2.54mm) Centers		
Side Exiting Terminals .200" (5.08mm) Centers		
Solder Lugs .200" (5.08mm) Centers		
Rear Facing Terminals .200" (5.08mm) Centers		
Hardware Included		X

Panel mount hardware not included as standard on bracketed versions.
The sample part number demonstrates the identification code for Bourns Slimline Potentiometers.
The part number shown is a commonly used model, typically available from stock.

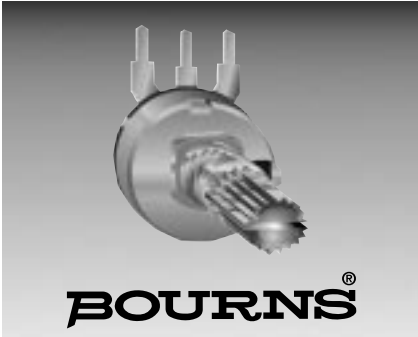

Features

- Carbon element
- Switch option
- Wide assortment of resistance tapers

Applications

- Audio/TV sets
- Car radio
- Amplifiers/mixers/drum machines/synthesizers
- PCs/monitors
- Appliances

PDA17 Series - 17mm Rotary Potentiometer

Electrical Characteristics

TaperA, B
 Standard Resistance Range1K ohms to 1M ohms
 Standard Nominal Resistance ValueSee standard resistance table
 Standard Resistance Tolerance±20%
 Residual ResistanceMax. 1% overall resistance

Environmental Characteristics

Power Rating
 Taper B0.1 watt
 Taper A0.05 watt
 Maximum Operating Voltage
 Taper B200 V
 Taper A150 V
 Sliding Noise47mV maximum

Physical Characteristics

Mechanical Angle260° ±10°
 Rotational Torque50 to 350 gcm
 Stop- End Strength5 kgcm minimum
 Switch Torque150 to 450 gfcm
 Switch Action Angle60° max.
 Rotational Life15,000 cycles minimum
 Soldering Condition260°C max. within 3 seconds

PDA17 Series Dimensions

K-Shaft (18 Toothed Serration Type)

L	20	25
	(.787)	(.984)
B	9	12
	(.354)	(.472)

Product Dimensions

PDA17-SS

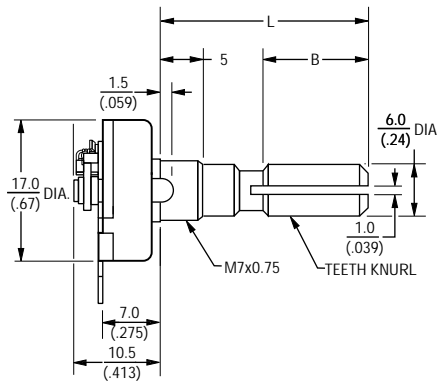

PDA17-SN

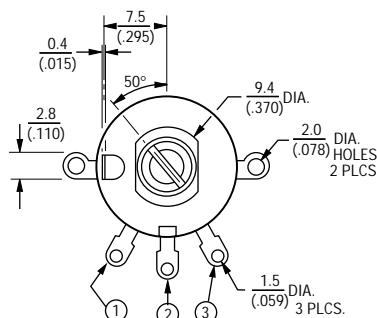
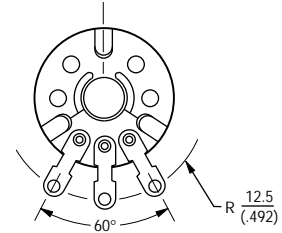
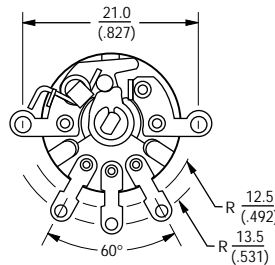
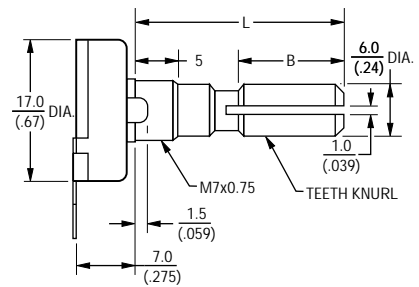

SHAFT SHOWN IN CCW POSITION

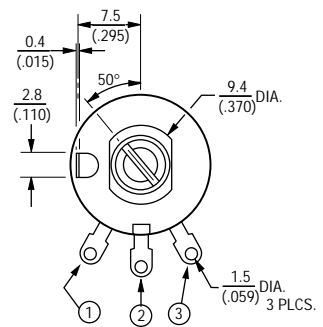

SHAFT SHOWN IN CCW POSITION

DIMENSIONS ARE: METRIC (INCHES)

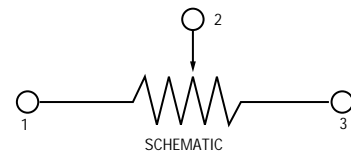

PDA17 Series - 17mm Rotary Potentiometer

Product Dimensions

PDA17-AN

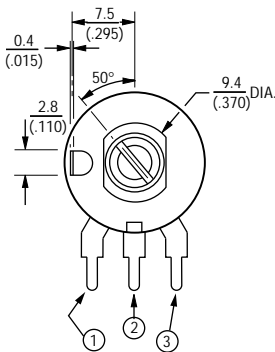
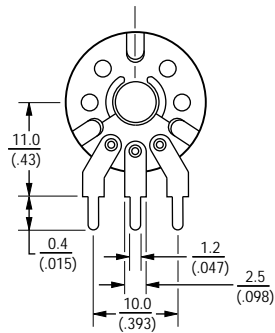
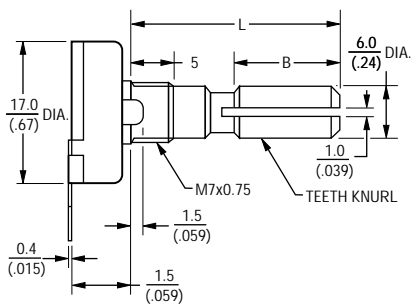

SHAFT SHOWN IN CCW POSITION

PDA17-VN

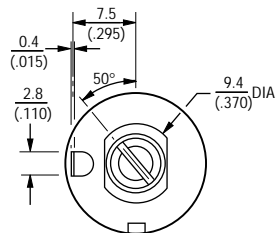
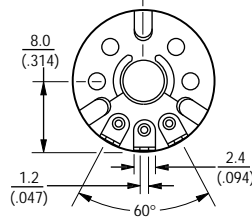
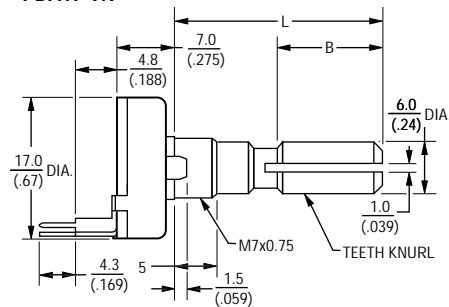

RECOMMENDED PCB LAYOUT

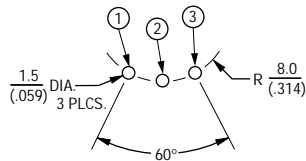

SHAFT SHOWN IN CCW POSITION

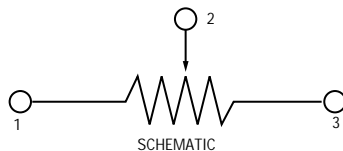

How To Order

PDA17 - V N 20 - 102 A K

- Model _____
- Terminal Configuration _____
- S = Solder Lugs
 - A = PC Pins vertical/Down Facing
 - V = PC Pins horizontal/Rear Facing
- Switch Option _____
- S = Switch
 - N = No Switch
- Standard Shaft Length _____
- 20 = 20mm
 - 25 = 25mm
- Resistance Code (See Table) _____
- Resistance Taper _____
- A = Audio Taper
 - B = Linear Taper
- Shaft Style _____
- K = Metal Knurled Shaft
18 Toothed Serration Type
- Other configurations or styles available.

Standard Resistance Table

Resistance (Ohms)	Resistance Code
1,000	102
2,000	202
5,000	502
10,000	103
20,000	203
50,000	503
100,000	104
200,000	204
500,000	504
1,000,000	105

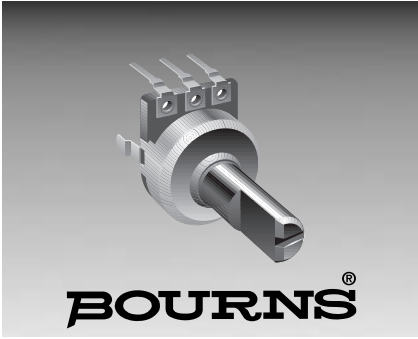

Features

- Single gang panel control
- Carbon element
- Center detent option
- Wide range of resistance tapers
- Insulated shaft styles
- Assortment of pin layouts

Applications

- Audio/TV sets
- Car radio
- Amplifiers/mixers/drum machines/synthesizers
- PCs/monitors
- Appliances

PDB12 Series - 12mm Rotary Potentiometer

Electrical Characteristics

TaperA, B
 Standard Resistance Range1K ohms to 1M ohms
 Standard Nominal Resistance ValueSee standard resistance table
 Standard Resistance Tolerance±20%
 Residual Resistance.....Max. 10 ohms

Environmental Characteristics

Power Rating
 Taper B0.08 watt
 Taper A0.04 watt
 Maximum Operating Voltage
 Taper B150 V
 Taper A100 V
 Sliding Noise.....47mV maximum

Physical Characteristics

Mechanical Angle300° ±5°
 Rotational Torque.....20 to 200 gcm
 Stop- End Strength3 kgcm minimum
 Rotational Life15,000 cycles minimum
 Soldering Condition260°C max.
 within 3 seconds

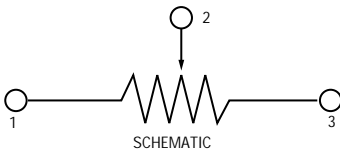

Product Dimensions

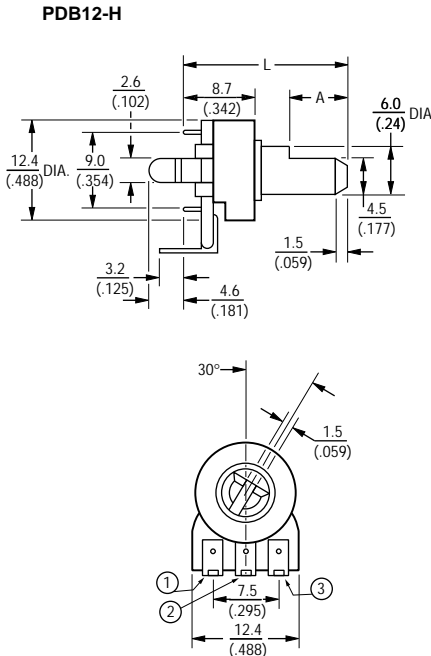

RECOMMENDED PCB LAYOUT

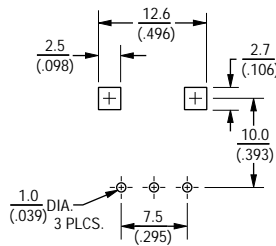

SHAFT SHOWN IN CCW POSITION

PDB12-H Dimensions

L	20	25
	(.787)	(.984)
A	7	12
	(.275)	(.472)

DIMENSIONS ARE: METRIC / (INCHES)

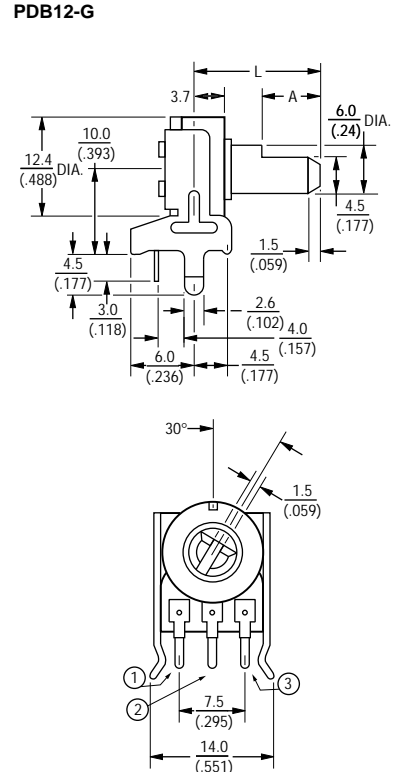

RECOMMENDED PCB LAYOUT

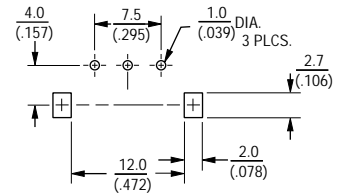

SHAFT SHOWN IN CCW POSITION

PDB12-G Dimensions

L	20	25
	(.787)	(.984)
A	7	12
	(.275)	(.472)

PDB12 Series - 12mm Rotary Potentiometer



Product Dimensions

PDB12-M

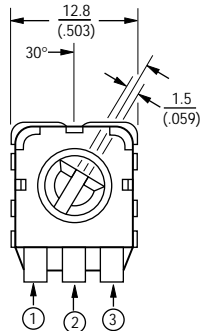
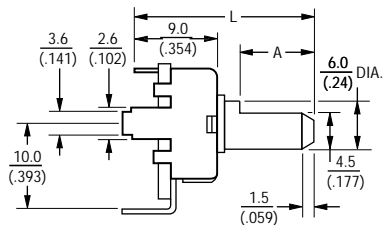

RECOMMENDED PCB LAYOUT

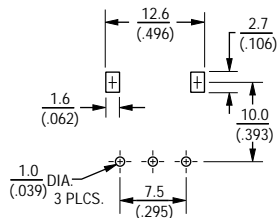

SHAFT SHOWN IN CCW POSITION

PDB12-M Dimensions

L	20	25
	(.787)	(.984)
A	7	12
	(.275)	(.472)

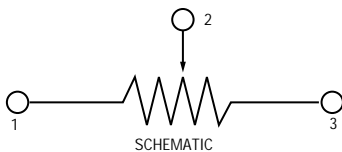

PDB12-F

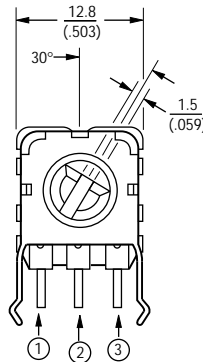
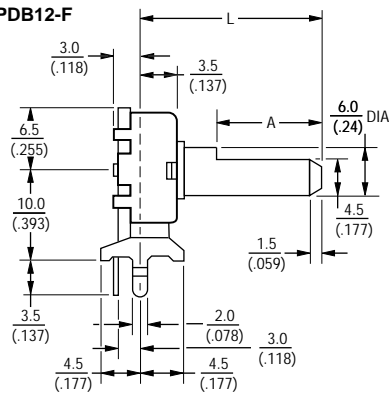

RECOMMENDED PCB LAYOUT

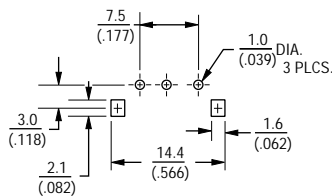

SHAFT SHOWN IN CCW POSITION

PDB12-F Dimensions

L	20	25
	(.787)	(.984)
A	7	12
	(.275)	(.472)

How To Order

PDB12 - H 4 20 1 - 103 A F

- Model _____
- Terminal Config. _____
(See individual drawings)
- Option _____
• 2 = Center Detent
• 4 = No Detent
- Standard Shaft Length _____
• 20 = 20mm
• 25 = 25mm
- Number of Gangs _____
• 1 = Single Gang
- Resistance Code (See Table) _____
- Resistance Taper _____
• A = Audio Taper
• B = Linear Taper
- Shaft Style _____
• F = Flat Type Insulated Shaft
- Other styles available.

Standard Resistance Table

Resistance (Ohms)	Resistance Code
1,000	102
2,000	202
5,000	502
10,000	103
20,000	203
50,000	503
100,000	104
200,000	204
500,000	504
1,000,000	105

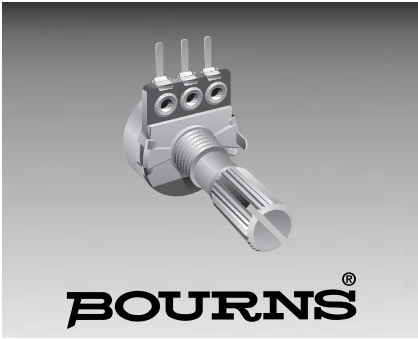

BOURNS®

Features

- Single and dual section control
- Metal shaft styles
- Carbon element
- Center detent option
- Wide range of resistance tapers

Applications

- Audio/TV sets
- Car radio
- Amplifiers/mixers/drum machines/synthesizers
- PCs/monitors
- Appliances

PDB18 Series - 18mm Rotary Potentiometer

Electrical Characteristics

TaperA, B
 Standard Resistance Range1K ohms to 1M ohms
 Standard Resistance Tolerance±20%
 Standard Nominal Resistance ValueSee standard resistance table
 Residual ResistanceMaximum 1%

Environmental Characteristics

Power Rating
 Taper B0.2 watt
 Dual Section0.125 watt
 Taper A0.1 watt
 Dual Section0.06 watt
 Maximum Operating Voltage
 Taper B200 V
 Taper A150 V
 Sliding Noise47mV maximum

Physical Characteristics

Mechanical Angle300° ±5°
 Rotational Torque50 to 350 gcm
 Click Torque150 to 500 gcm
 Stop- End Strength5 kgcm minimum
 Rotational Life15,000 cycles minimum
 Soldering Condition260°C max.
 within 3 seconds

How To Order

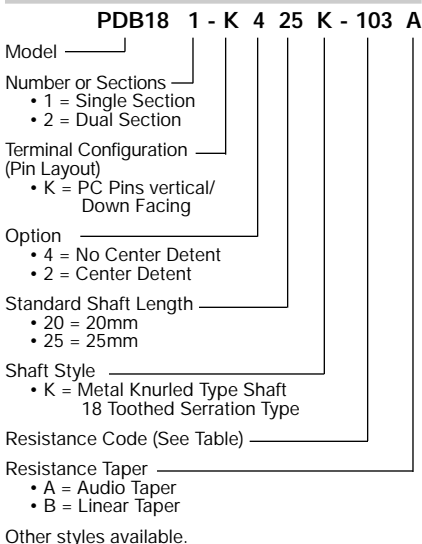

Product Dimensions

PDB181-K

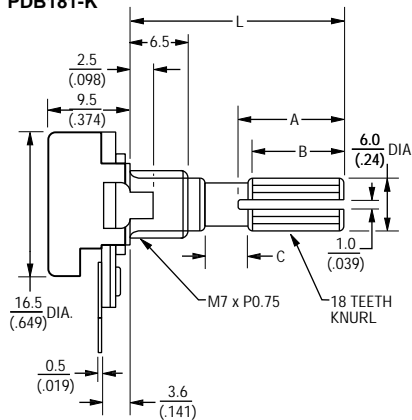

PDB182-K

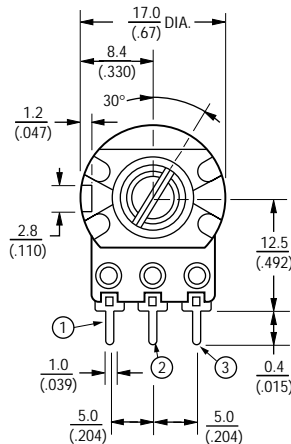
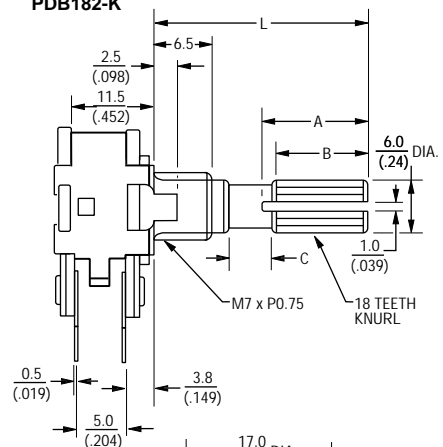

SHAFT SHOWN IN CCW POSITION

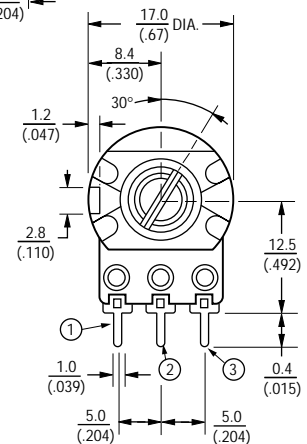

SHAFT SHOWN IN CCW POSITION

Standard Resistance Table

Resistance (Ohms)	Resistance Code
1,000	102
2,000	202
5,000	502
10,000	103
20,000	203
50,000	503
100,000	104
200,000	204
500,000	504
1,000,000	105

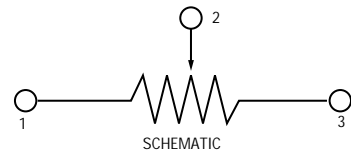

PDB18 Dimensions

L	20	25
	(.787)	(.984)
A	12	14
	(.472)	(.551)
B	10	12
	(.393)	(.472)
C	2	2
	(.078)	(.078)

DIMENSIONS ARE: METRIC
 (INCHES)

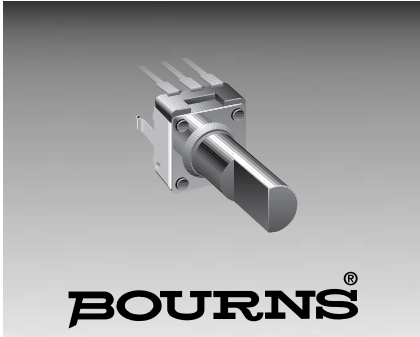

Features

- Carbon element
- Insulated shaft
- Snap-in clip
- Center detent option

Applications

- Audio/TV sets
- Car radio
- Amplifiers/mixers/drum machines/synthesizers
- PCs/monitors
- Appliances

PTV09 Series - 9mm Potentiometer

Electrical Characteristics

Taper A, B
 Standard Resistance Range 1K ohms to 1M ohms
 Standard Resistance Tolerance $\pm 20\%$
 Standard Nominal Resistance Value See standard resistance table
 Residual Resistance 500 ohms maximum or $\pm 1\%$

Environmental Characteristics

Power Rating 0.05 watt
 Maximum Operating Voltage 20 VDC, 50 VAC
 Sliding Noise 100mV maximum

Physical Characteristics

Mechanical Angle $280^\circ \pm 5^\circ$
 Rotational Torque 10 to 100 gcm
 Click Torque 40 to 200 gcm
 Stop-End Strength 3 kgcm minimum
 Rotational Life 10,000 cycles minimum
 Soldering Condition 300°C max.
 within 3 seconds

How To Order

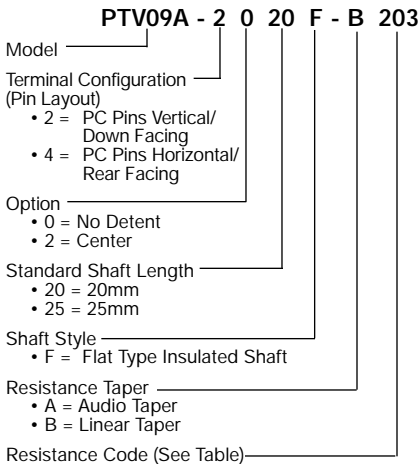

Other styles available.

Product Dimensions

PTV09A-2

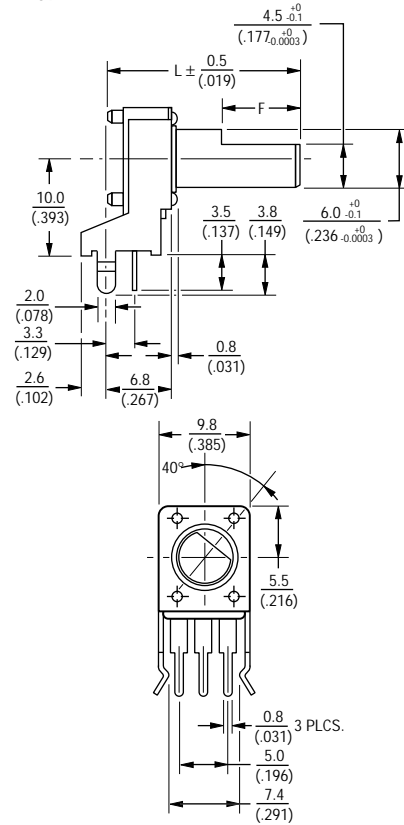

RECOMMENDED PCB LAYOUT

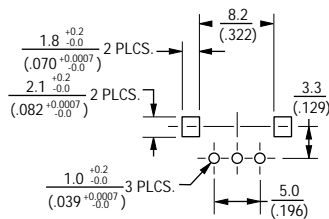

SHAFT SHOWN IN CCW POSITION

PTV09 Dimensions

L	20	25
	(.787)	(.984)
F	7	12
	(.275)	(.472)

DIMENSIONS ARE: $\frac{\text{METRIC}}{\text{(INCHES)}}$

PTV09A-4

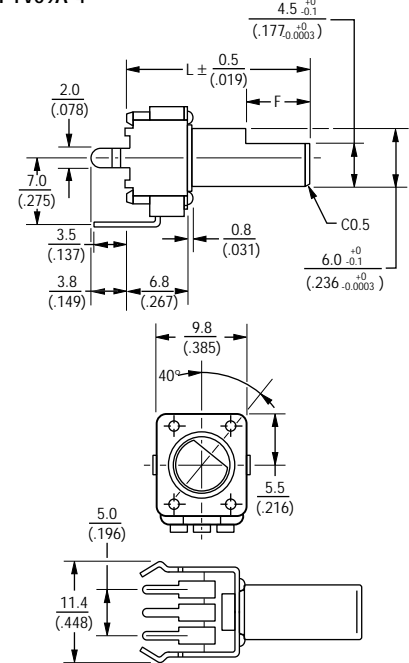

RECOMMENDED PCB LAYOUT

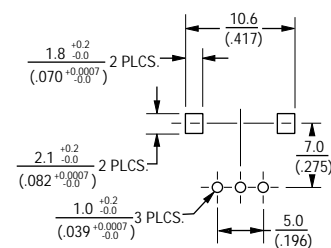

Standard Resistance Table

Resistance (Ohms)	Resistance Code
1,000	102
2,000	202
5,000	502
10,000	103
20,000	203
50,000	503
100,000	104
200,000	204
500,000	504
1,000,000	105



BOURNS®

Features

- Carbon element
- Insulated shaft
- Snap-in clip
- Center detent
- Center tap option
- Assorted pin layouts

Applications

- Audio/TV sets
- Car radio
- Amplifiers/mixers/drum machines/synthesizers
- PCs/monitors
- Appliances

PTV111/PTT111 - 11mm Potentiometer

Electrical Characteristics

TaperA, B
 Standard Resistance Range1K ohms to 1M ohms
 Standard Resistance Tolerance±20%
 Standard Nominal Resistance ValueSee standard resistance table
 Residual ResistanceMaximum 1%

Environmental Characteristics

Power Rating0.05 Watt
 Maximum Operating Voltage50V AC, 20V DC
 Sliding Noise100mV maximum

Physical Characteristics

Mechanical Angle300° ±5°
 Rotational Torque20 to 200 gcm
 Click Torque30 to 300 gcm
 Stop- End Strength
 no bushing5 kgcm minimum
 with bushing6 kgcm minimum
 Rotational Life10,000 cycles minimum
 Soldering Condition300°C max.
 within 3 seconds

Electrical Diagrams

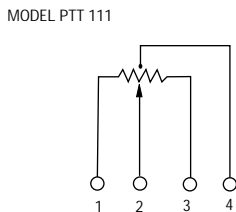
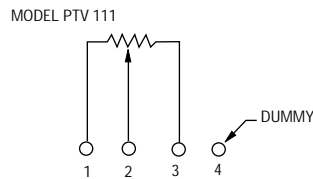

Product Dimensions

PTV111-2

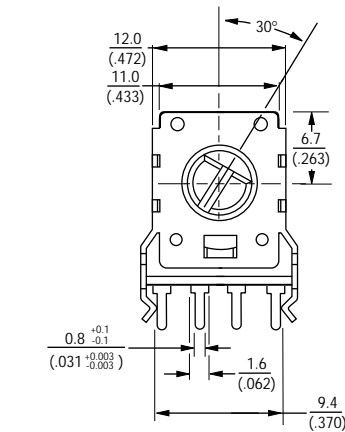
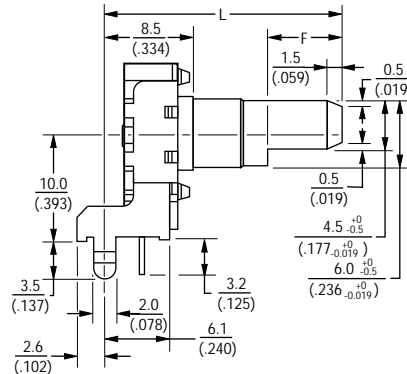

RECOMMENDED PCB LAYOUT

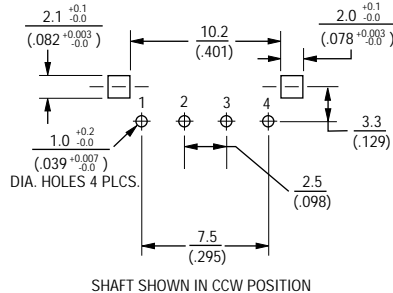

SHAFT SHOWN IN CCW POSITION

PTV111-4

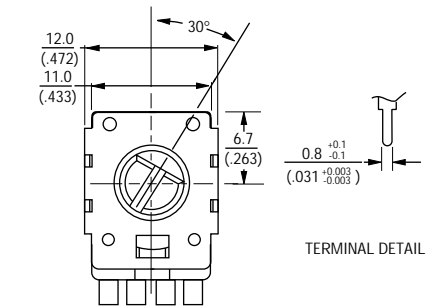
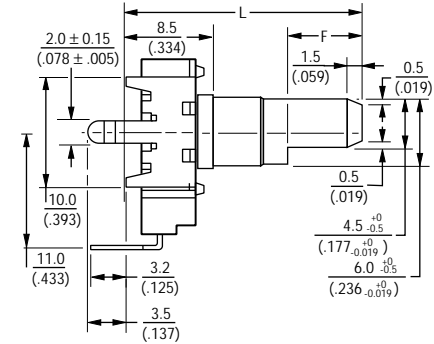

TERMINAL DETAIL

RECOMMENDED PCB LAYOUT

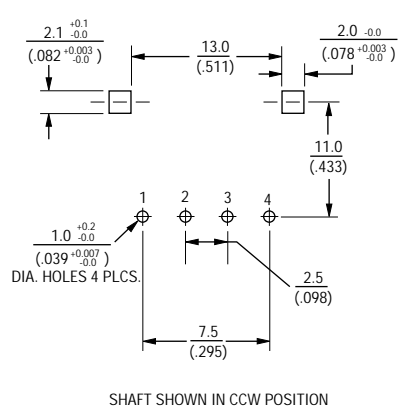

SHAFT SHOWN IN CCW POSITION

Dimensions Without Bushing

L	20	25
	(.787)	(.984)
F	7	12
	(.275)	(.472)

DIMENSIONS ARE: METRIC
 (INCHES)

PTV111/PTT111 - 11mm Potentiometer



Product Dimensions

PTV111-1

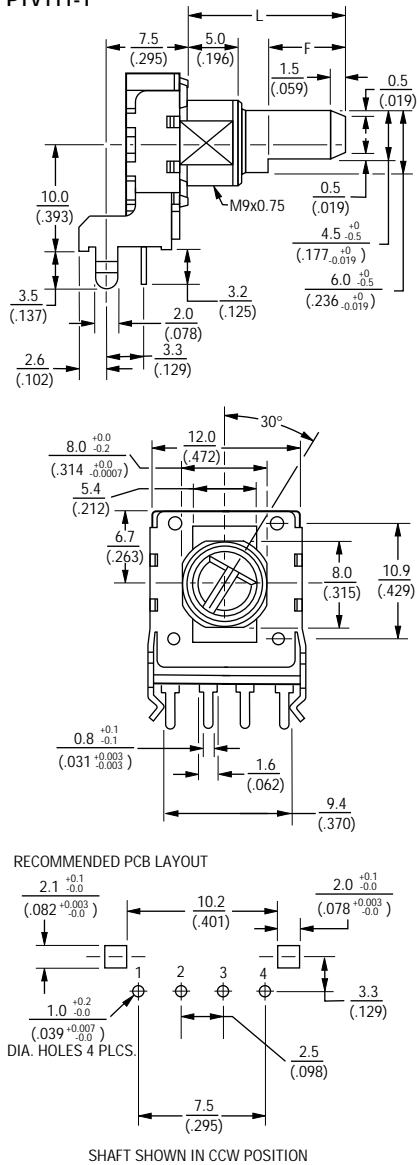

PTV111-3

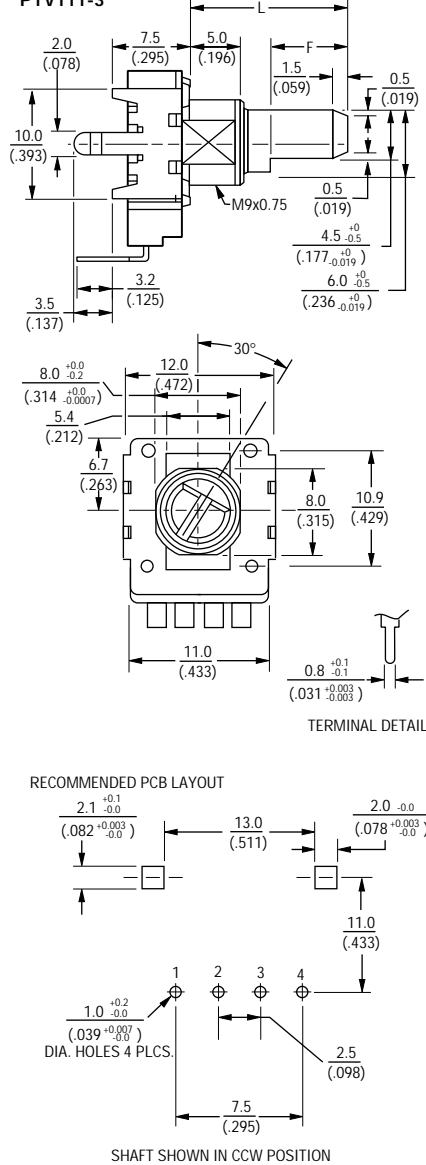

How To Order

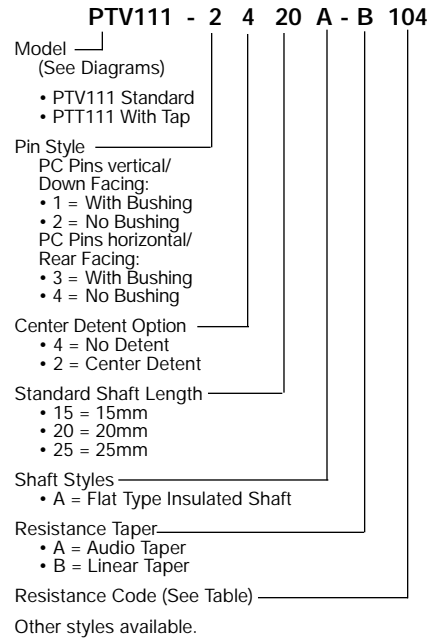

Standard Resistance Table

Resistance (Ohms)	Resistance Code
1,000	102
2,000	202
5,000	502
10,000	103
20,000	203
50,000	503
100,000	104
200,000	204
500,000	504
1,000,000	105

Dimensions With Bushing

L	15	20
	(.590)	(.787)
F	7	12
	(.275)	(.472)

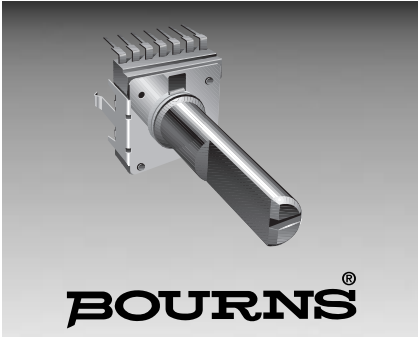

BOURNS®

Features

- Carbon element
- Insulated shaft
- Snap-in clip
- Center detent option
- Assorted pin layouts

Applications

- Audio/TV sets
- Car radio
- Amplifiers/mixers/drum machines/synthesizers
- PCs/monitors
- Appliances

PTV142 - 14mm Dual Potentiometer

Electrical Characteristics

TaperA, B
 Standard Resistance Range1K ohms to 1M ohms
 Standard Resistance Tolerance±20%
 Standard Nominal Resistance ValueSee standard resistance table
 Residual Resistance500 ohms maximum or 1% of nominal resistance

Environmental Characteristics

Power Rating0.05 watt
 Maximum Operating Voltage50V AC
 Sliding Noise100mV maximum

Physical Characteristics

Mechanical Angle30° ±5°
 Rotational Torque.....20 to 200 gcm
 Click Torque30 to 300 gcm
 Stop- End Strength6 kgcm minimum
 Rotational Life15,000 cycles minimum
 Soldering Condition300°C max. within 3 seconds

How To Order

PTV142 B - 2 0 E 1 20 A - A 203

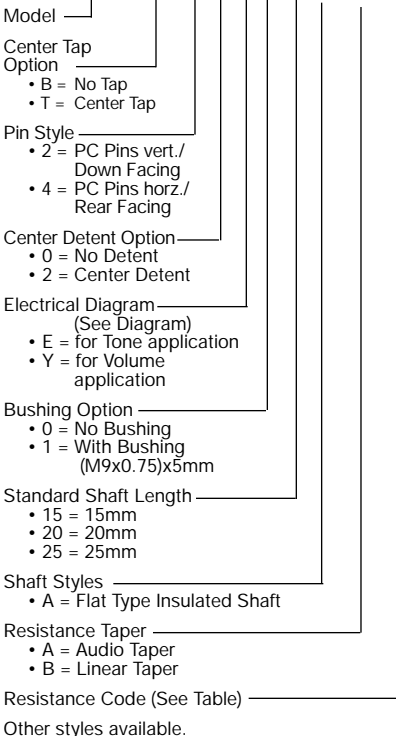

Product Dimensions

PTV142B-2 No Bushing

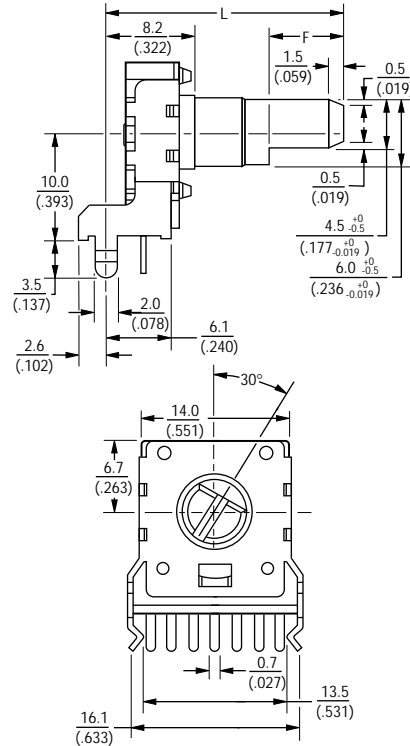

RECOMMENDED PCB LAYOUT

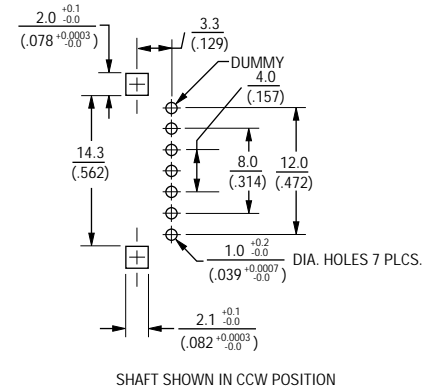

PTV142B-4 No Bushing

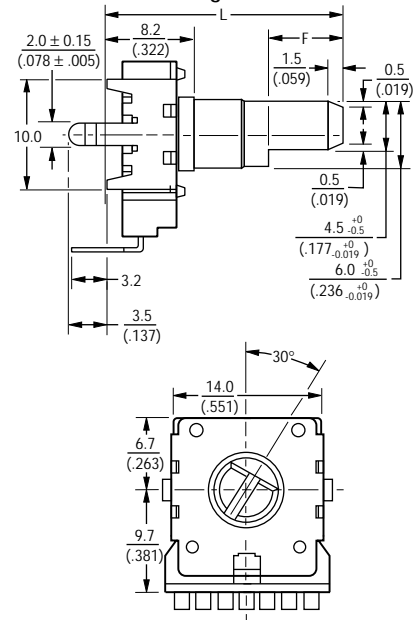

RECOMMENDED PCB LAYOUT

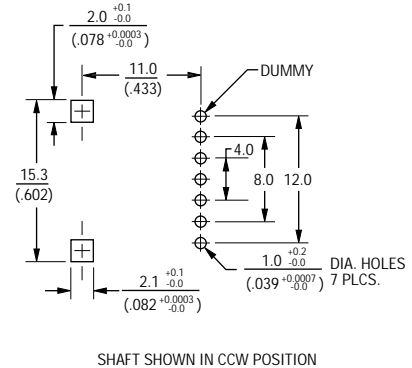

DIMENSIONS ARE: METRIC (INCHES)

Dimensions Without Bushing

L	20	25
	(.787)	(.984)
F	7	12
	(.275)	(.472)

PTV142 - 14MM Dual Potentiometer

Product Dimensions

PTV142B-2 With Bushing

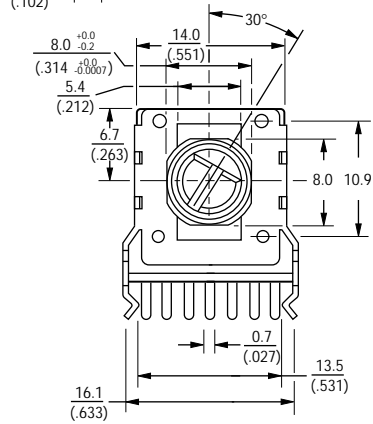
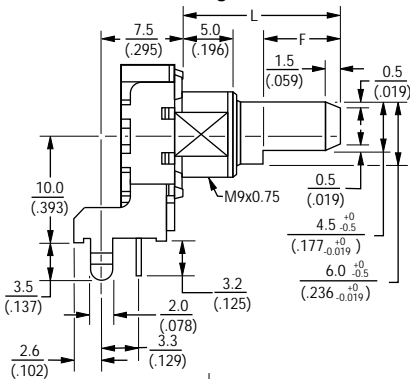

RECOMMENDED PCB LAYOUT

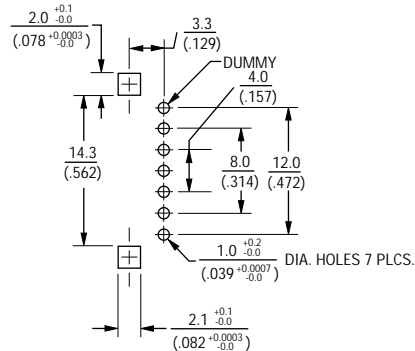

SHAFT SHOWN IN CCW POSITION

PTV142B-4 With Bushing

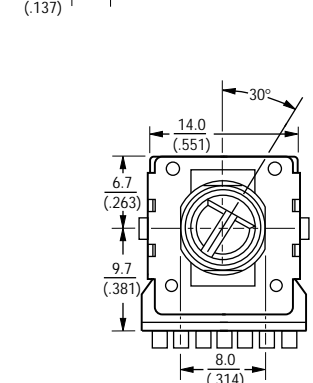
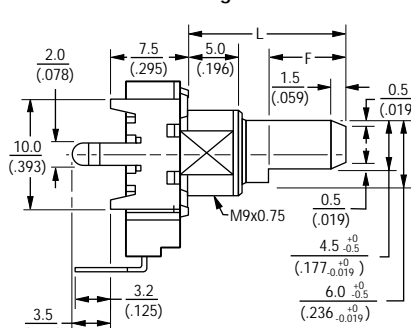

RECOMMENDED PCB LAYOUT

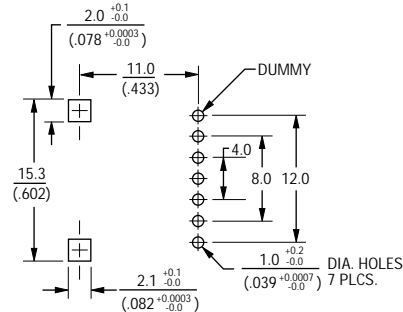

SHAFT SHOWN IN CCW POSITION

Dimensions Without Bushing

L	15	20
	(.590)	(.787)
F	7	12
	(.275)	(.472)

Electrical Diagrams

"E" FOR TONE APPLICATION

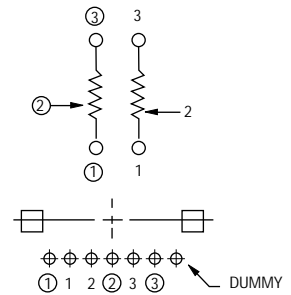

"Y" FOR VOLUME APPLICATION

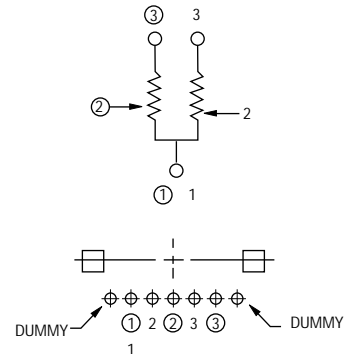

"Y" WITH TAP

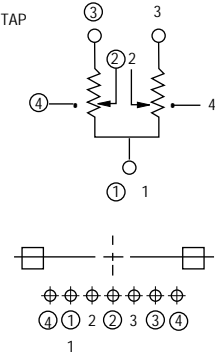

Standard Resistance Table

Resistance (Ohms)	Resistance Code
1,000	102
2,000	202
5,000	502
10,000	103
20,000	203
50,000	503
100,000	104
200,000	204
500,000	504
1,000,000	105

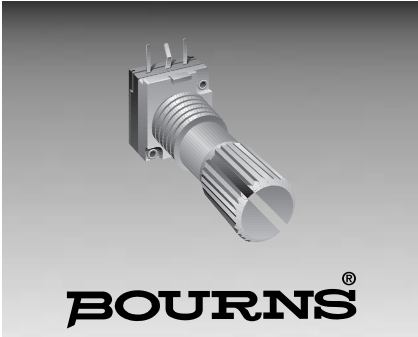

BOURNS[®]

Features

- Carbon element
- 1 to 4 sections
- Assorted metal shaft styles
- Assortment of resistance tapers
- Tracking error within 3 dB
- Switch option

Applications

- Audio/TV sets
- Car radio
- Amplifiers/mixers/drum machines/synthesizers
- PCs/monitors
- Appliances

PTD90/PTR90 - 9mm Multi-Ganged Potentiometer

Electrical Characteristics

TaperA, B
 Standard Resistance Range1K ohms to 1M ohms
 Standard Resistance Tolerance±20%
 Standard Nominal Resistance ValueSee standard resistance table
 Residual ResistanceMaximum 5 ohms between terminals 1&2 and 2&3

Environmental Characteristics

Power Rating0.05 watt
 Maximum Operating Voltage50V AC, 10V DC
 Tracking Error ..at 50% angle max. ±3dB
 Sliding Noise.....100mV maximum

Physical Characteristics

Mechanical Angle300° ±5°
 Rotational Torque.....20 to 200 gcm
 Stop- End Strength4 kgcm minimum
 Rotational Life10,000 cycles minimum
 Soldering Condition300°C max. within 3 seconds

How To Order

PTD90 1 - 2 0 20 K - B 203

Model

- PTD90 = No Switch
- PTR90 = With Rotary Switch

No. of Sections

- 1 = 1 Section
- 2 = 2 Sections
- 4 = 4 Sections

Pin Style

- 2 = PC Pins vertical/Down Facing

Center Detent Option

- 0 = No Detent
- 2 = Center Detent

Standard Shaft Length

- 15 = 15mm
- 20 = 20mm
- 25 = 25mm

Shaft Styles

- K = Knurled Type Shaft (Metal) 18 Toothed Serration Type

Resistance Taper

- A = Audio Taper
- B = Linear Taper

Resistance Code (See Table)

Other styles available.

Product Dimensions

PTD901

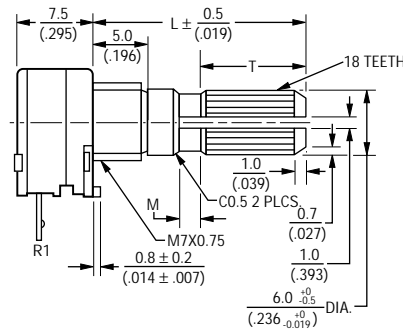

PTD902

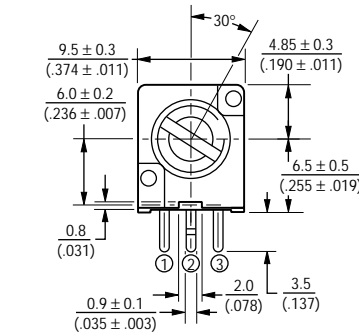
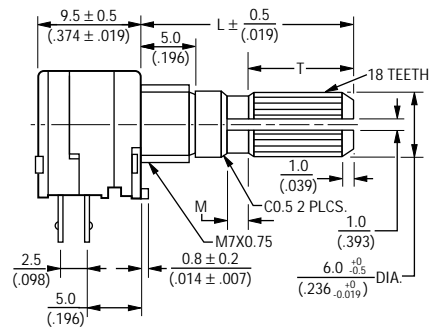

RECOMMENDED PCB LAYOUT

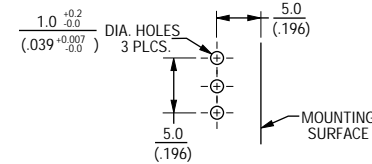

SHAFT SHOWN IN CCW POSITION

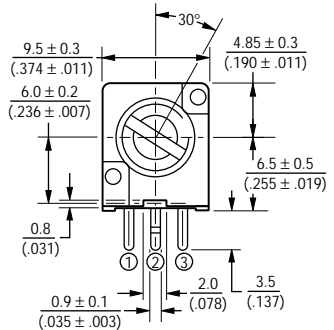

RECOMMENDED PCB LAYOUT

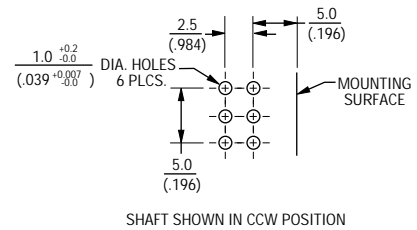

PTD90 Dimensions

L	15	20	25
	(.590)	(.787)	(.984)
T	6	10	12
	(.236)	(.393)	(.472)
M	1.5	2	4
	(.059)	(.078)	(.157)

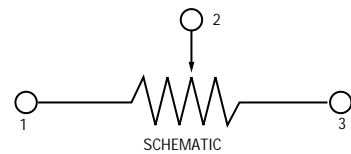

DIMENSIONS ARE: METRIC (INCHES)

PTD90/PTR90 - 9mm Multi-Ganged Potentiometer

BOURNS®

Product Dimensions

PTD904

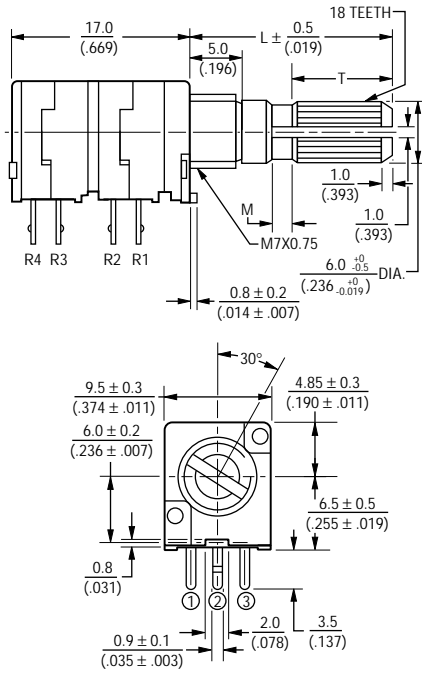

RECOMMENDED PCB LAYOUT

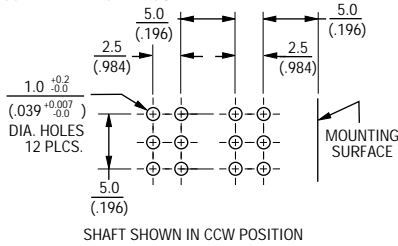

PTR902

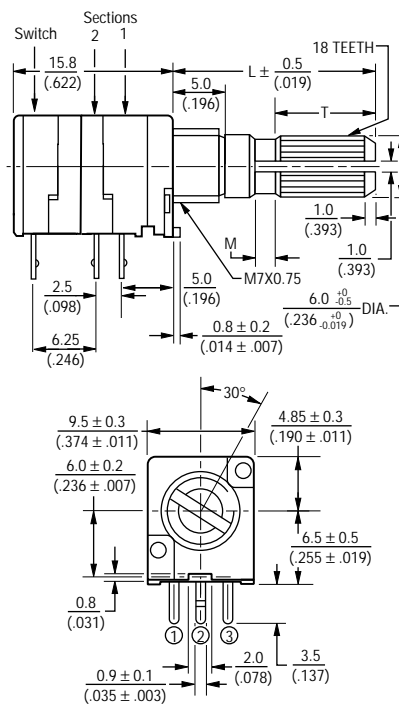

RECOMMENDED PCB LAYOUT

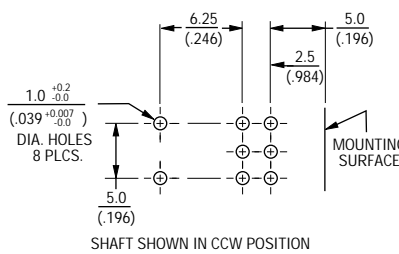

Standard Resistance Table

Resistance (Ohms)	Resistance Code
1,000	102
2,000	202
5,000	502
10,000	103
20,000	203
50,000	503
100,000	104
200,000	204
500,000	504
1,000,000	105

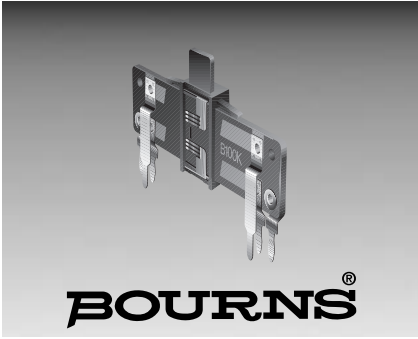

BOURNS®

Features

- Carbon element
- 10-30mm travel
- Center detent option
- Single or dual gang

Applications

- Audio/TV sets
- Car radio
- Amplifiers/mixers/drum machines/synthesizers
- PCs/monitors
- Appliances

PDV Series - Open Frame Slide Potentiometer

Electrical Characteristics

TaperA, B
 Standard Resistance Range1K ohms to 1M ohms
 Standard Nominal Resistance ValueSee standard resistance table
 Residual Resistance100 ohms maximum or ±5%

Environmental Characteristics

Power Rating
 Taper B0.1 watt
 Taper A0.05 watt
 Maximum Operating Voltage
 Taper B150 V
 Taper A100 V
 Sliding Noise47mV maximum

Physical Characteristics

Standard Stroke Length10, 15, 20, 30mm
 Sliding Force20 to 300 gcm
 Click Torque50 to 400 gcm
 Stop- End Strength3 kgcm minimum
 Sliding Life10,000 cycles minimum
 Soldering Condition260°C max. within 3 seconds

How To Order

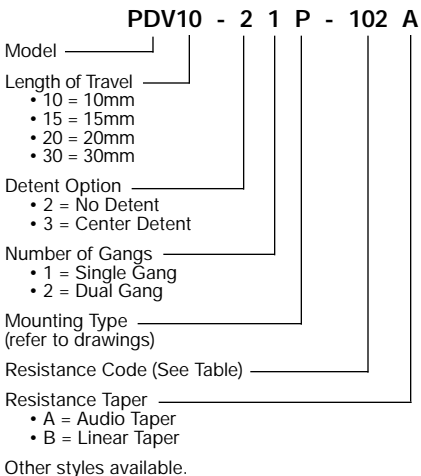

Product Dimensions

PDVxx-x1D

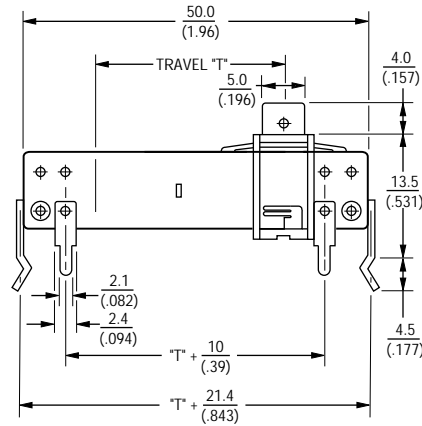

PDVxx-x2D

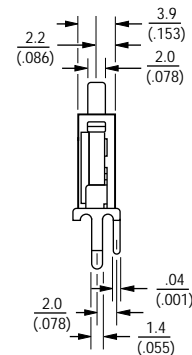
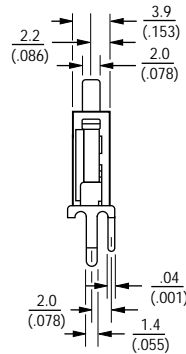
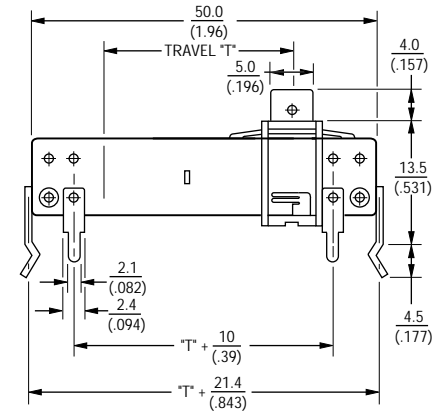

RECOMMENDED PCB LAYOUT

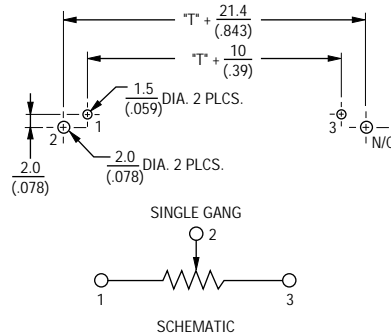

RECOMMENDED PCB LAYOUT

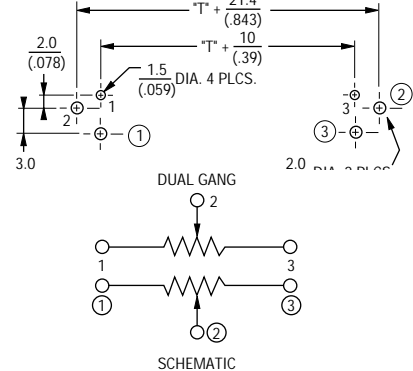

DIMENSIONS ARE: METRIC / (INCHES)

PDV Series - Open Frame Slide Potentiometer



Product Dimensions

PDVxx-x1P

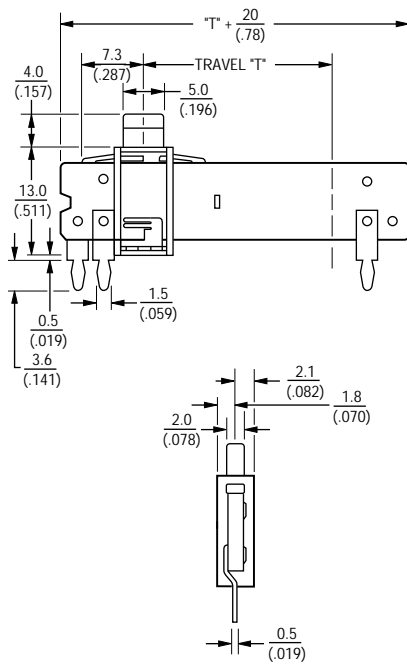

PDVxx-x2P

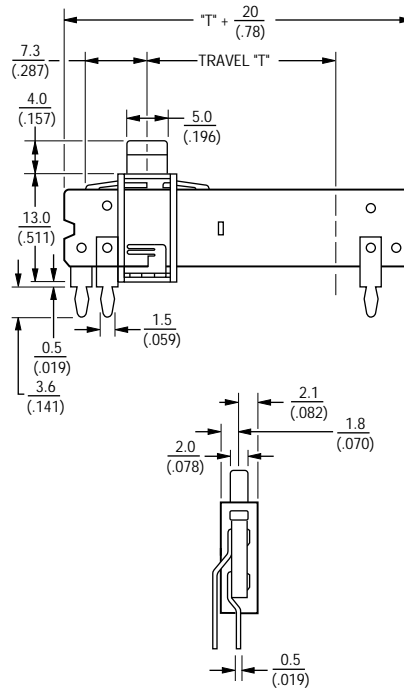

RECOMMENDED PCB LAYOUT

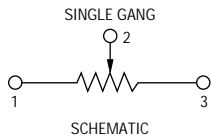
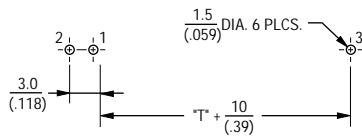

RECOMMENDED PCB LAYOUT

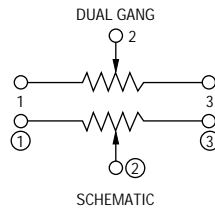
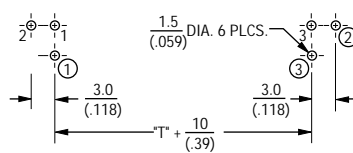

Standard Resistance Table

Resistance (Ohms)	Resistance Code
1,000	102
2,000	202
5,000	502
10,000	103
20,000	203
50,000	503
100,000	104
200,000	204
500,000	504
1,000,000	105

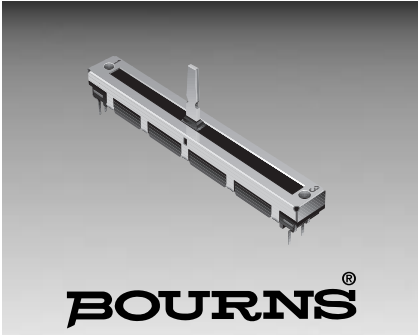

BOURNS®

Features

- Carbon element
- Metal housing
- 15-60mm travel
- Single and dual gang
- Center detent option
- Dust cover option

Applications

- Audio/TV sets
- Car radio
- Amplifiers/mixers/drum machines/synthesizers
- PCs/monitors
- Appliances

PTA Series - Low Profile Slide Potentiometer

Electrical Characteristics

TaperA, B
 Standard Resistance Range1K ohms to 1M ohms
 Standard Nominal Resistance ValueSee standard resistance table
 Standard Resistance Tolerance±20%
 Residual Resistance500 ohms maximum or 1%
 Insulation ResistanceMin. 100 megohms at 250V DC

Environmental Characteristics

Power Rating, B Taper
 15mm0.05W (0.025W Dual Gang)
 20mm0.1W (0.05W)
 30mm0.2W (0.1W)
 45mm0.25W (0.125W)
 60mm0.25W (0.125W)

Power Rating, A Taper
 15mm0.025W (0.015W Dual Gang)
 20mm0.05W (0.025W)
 30mm0.1W (0.05W)
 45mm0.125W (0.06W)
 60mm0.125W (0.06W)

Rated Voltage, B Taper
 15mm100V DC
 20-60mm200V DC

Rated Voltage, A Taper
 15mm50V DC
 20-60mm150V DC

Withstand Voltage, A Taper1 Min. at 300V AC

Tracking Error3 dB at -40 to 0 dB
Sliding Noise100mV maximum

Physical Characteristics

Travel15, 20, 30, 45, 60mm
Operating Force30 to 250 gcm
Lever Stop Strength5 kgcm min.
Rotational Life15,000 cycles minimum
Soldering Condition300°C max. within 3 seconds

Lever Style & Product Dimensions

Actuator Styles

DP METAL LEVER

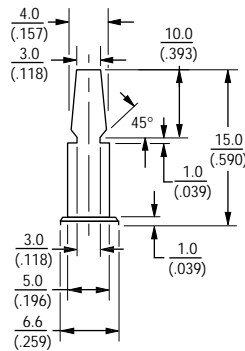

CP METAL LEVER

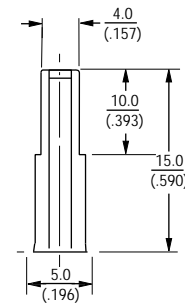

CI INSULATED LEVER

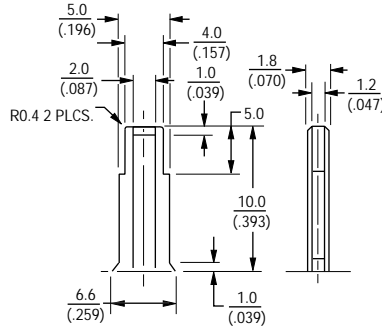

How To Order

PTA 15 4 3 - 2 0 10 DP - B 203

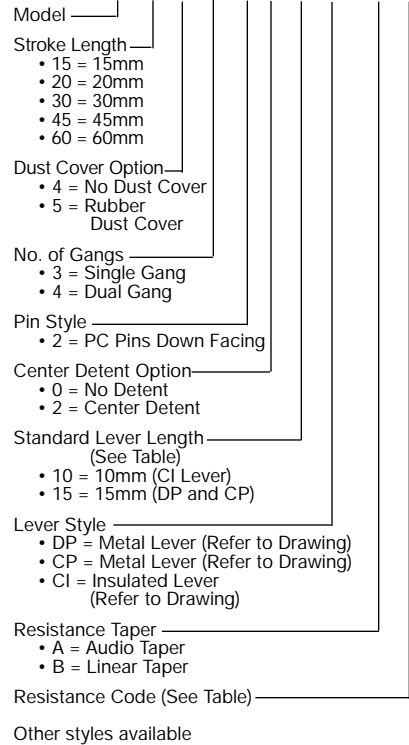

Standard Resistance Table

Resistance (Ohms)	Resistance Code
1,000	102
2,000	202
5,000	502
10,000	103
20,000	203
50,000	503
100,000	104
200,000	204
500,000	504
1,000,000	105

DIMENSIONS ARE: METRIC (INCHES)

PTA Series - Low Profile Slide Potentiometer



Product Dimensions

PTAxx43

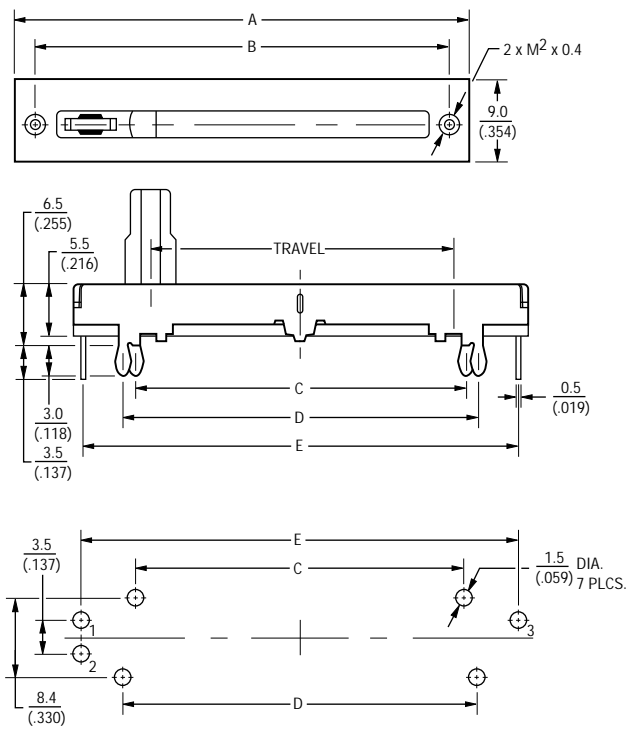

PTAxx44

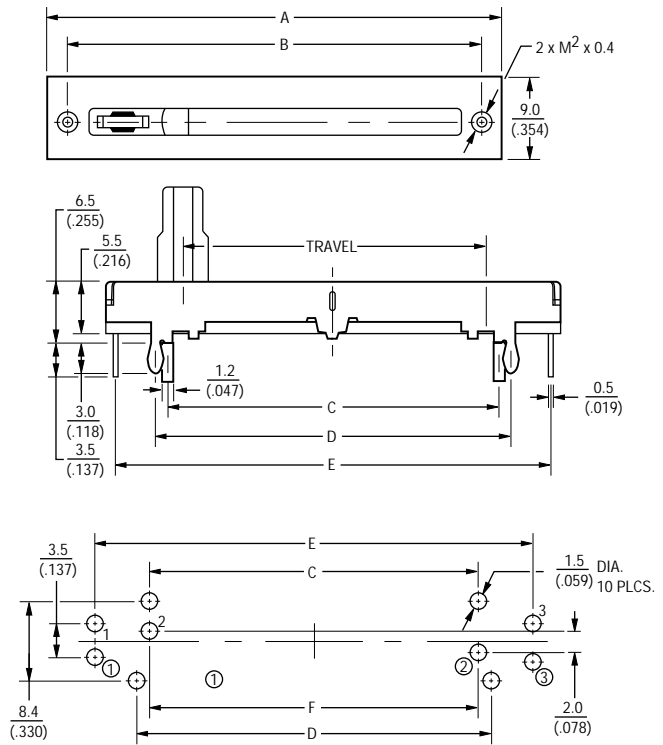

Single Gang Dimensions

Model	A	B	C	D	E	Travel
PTA1543	30 (.318)	26 (1.02)	17.8 (.700)	20.2 (.795)	28.5 (1.12)	15mm (.59)
PTA2043	35 (1.37)	31 (1.22)	22.8 (.897)	25.2 (.992)	33.5 (1.31)	20mm (.787)
PTA3043	45 (1.77)	41 (1.61)	32.8 (1.29)	35.2 (1.38)	43.5 (1.71)	30mm (1.18)
PTA4543	60 (2.36)	56 (2.20)	47.8 (1.88)	50.2 (1.97)	58.5 (2.30)	45mm (1.77)
PTA6043	75 (2.95)	71 (2.79)	62.8 (2.47)	65.2 (2.56)	73.5 (2.89)	60mm (2.36)

Dual Gang Dimensions

Model	A	B	C	D	E	F	Travel
PTA1544	30 (.318)	26 (1.02)	17.8 (.700)	20.2 (.795)	28.5 (1.12)	18 (.708)	15mm (.59)
PTA2044	35 (1.37)	31 (1.22)	22.8 (.897)	25.2 (.992)	33.5 (1.31)	23 (.905)	20mm (.787)
PTA3044	45 (1.77)	41 (1.61)	32.8 (1.29)	35.2 (1.38)	43.5 (1.71)	33 (1.29)	30mm (1.18)
PTA4544	60 (2.36)	56 (2.20)	47.8 (1.88)	50.2 (1.97)	58.5 (2.30)	48 (1.88)	45mm (1.77)
PTA6044	75 (2.95)	71 (2.79)	62.8 (2.47)	65.2 (2.56)	73.5 (2.89)	63 (2.48)	60mm (2.36)

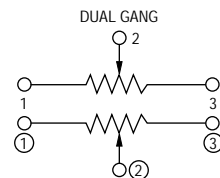
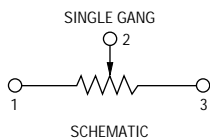



Features

- Carbon element
- Metal housing
- 45 - 100mm travel
- Single and dual gang
- Dust cover option

Applications

- Audio/TV sets
- Car radio
- Amplifiers/mixers/drum machines/synthesizers
- PCs/monitors
- Appliances

PTB Series - Low Profile Slide Potentiometer

Electrical Characteristics

TaperA, B
 Standard Resistance Range1K ohms to 1M ohms
 Standard Nominal Resistance ValueSee standard resistance table
 Standard Resistance Tolerance±20%
 Residual Resistance500 ohms maximum or 1%
 Insulation ResistanceMin. 100 megohms at 250V DC

Environmental Characteristics

Power Rating, B Taper
 45mm0.125W (0.06W Dual Gang)
 60mm0.25W (0.125W)
 100mm0.5W (0.5W)
 Power Rating, A Taper
 45mm0.025W (0.015W Dual Gang)
 60mm0.25W (0.125W)
 100mm0.25W (0.25W)
 Rated Voltage, B Taper
 45mm350V DC
 60-100mm500V DC
 Rated Voltage, A Taper
 45mm250V DC
 60-100mm350V DC
 Withstand Voltage, A Taper1 Min. at 500V AC
 Tracking Error3 dB at -40 to 0 dB

Physical Characteristics

Travel45, 60, 100mm
 Operating Force50 to 350 gcm
 Lever Stop Strength5 kgcm min.
 Rotational Life15,000 cycles minimum
 Soldering Condition300°C max. within 3 seconds

Product Dimensions

PTB45 and PTB60

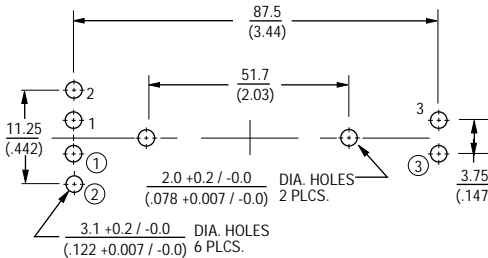
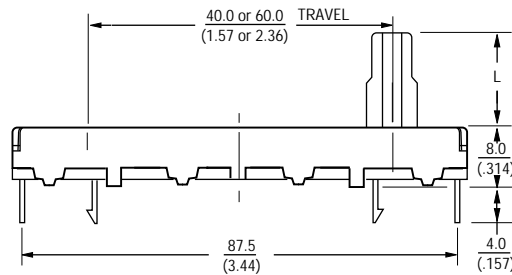
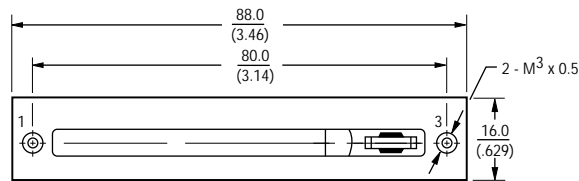

Numbers ①, ② and ③ for Dual Gang Versions

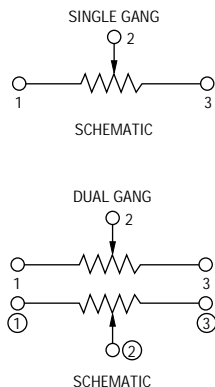

Lever Style
BP Metal Lever

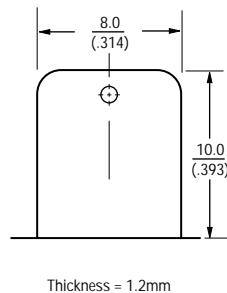

AP Metal Lever

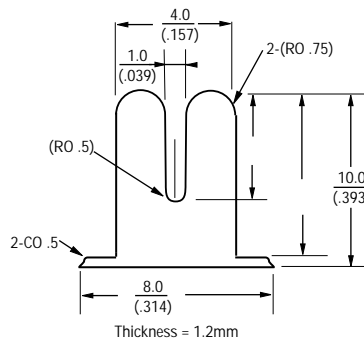

DIMENSIONS ARE: $\frac{\text{METRIC}}{\text{(INCHES)}}$

PTB Series - Low Profile Slide Potentiometer



Product Dimensions

PTB01

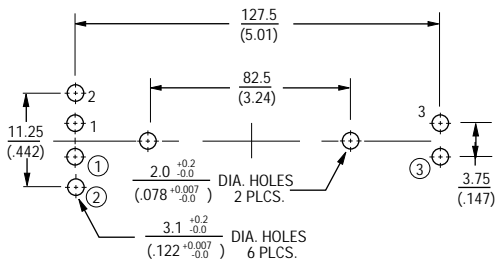
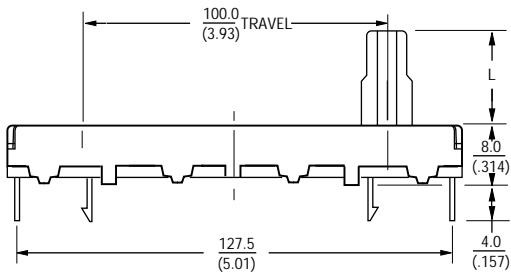
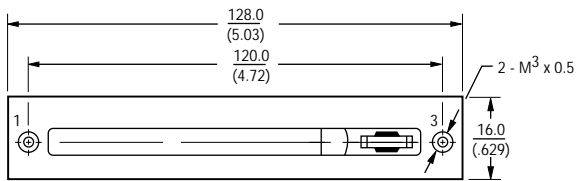

Numbers ①, ② and ③ for Dual Gang Versions

How To Order

PTB 01 4 3 - 2 0 10 BP - A 102

Model _____

Stroke Length _____

- 45 = 45mm
- 60 = 60mm
- 01 = 100mm

Dust Cover Option _____

- 4 = No Dust Cover
- 5 = Rubber Dust Cover

No. of Gangs _____

- 3 = Single Gang
- 4 = Dual Gang

Pin Style _____

- 2 = PC Pins Down Facing

No Detent _____

Standard Lever Length _____

- 10 = 10mm

Lever Style _____

- BP = Metal Lever (Refer to Drawing)
- AP = Metal Lever (Refer to Drawing)

Resistance Taper _____

- A = Audio Taper
- B = Linear Taper

Resistance Code (See Table) _____

Other styles available

Standard Resistance Table

Resistance (Ohms)	Resistance Code
1,000	102
2,000	202
5,000	502
10,000	103
20,000	203
50,000	503
100,000	104
200,000	204
500,000	504
1,000,000	105

Taper Characteristics

BOURNS®

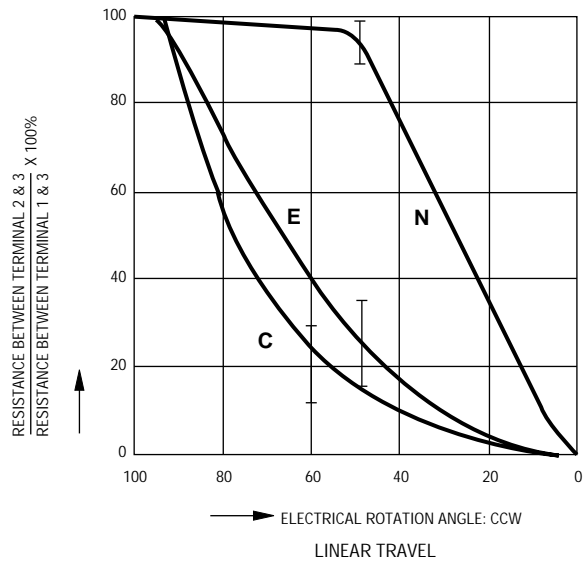
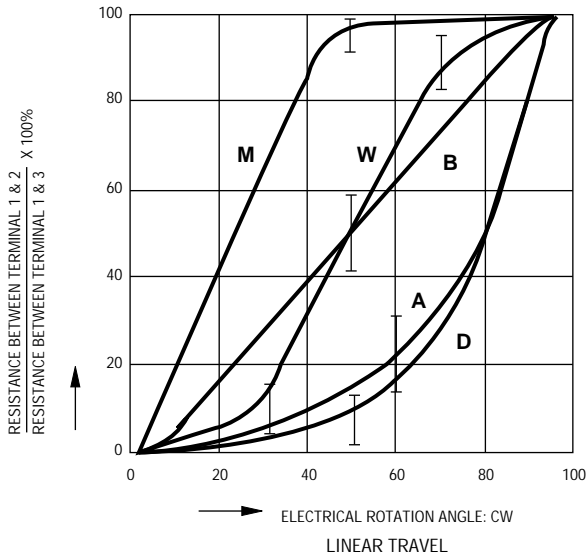

TEST METHOD

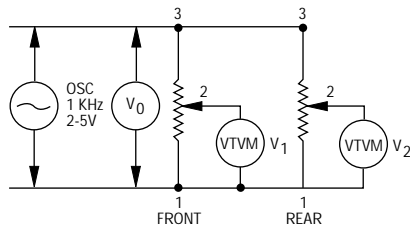

$$\text{GANG ERROR: } 20 \text{ LOG } \frac{V_2}{V_1} \text{ (dB)}$$

$$\text{ATTENUATION: } 20 \text{ LOG } \frac{V_1 \text{ OR } V_2}{V_0} \text{ (dB)}$$