



**Snap-In Capacitors**

**B41607**

**Automotive – Up to 150 °C**

**Long-life grade capacitors**

**Applications**

- High-reliability equipment in automotive power electronics, e.g. integrated starter alternator
- Applications with highest ripple current load at high frequencies

**Features**

- Outstanding high reliability and long useful life
- Outstanding ripple current capability optimized for high frequencies
- Can be operated at temperature up to 150 °C
- Vibration resistance 20 g upon request
- Overload protection (safety vent)

**Construction**

- Charge-discharge proof, polar
- Aluminum case, fully insulated
- Snap-in solder pins to hold component in place on PC-board
- Minus pole marking on case surface
- Minus pole not insulated from case

**Terminals**

- 3 terminals: length 4,5 mm  
(terminal arrangement ensures correct insertion)





B41607

Automotive – Up to 150 °C

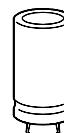

**Specifications and characteristics in brief**

Rated voltage $U_R$	25 ... 63 VDC									
Surge voltage $U_S$	$1,15 \cdot U_R$									
Rated capacitance $C_R$	800 ... 3300 $\mu$ F									
Capacitance tolerance	$\pm 20 \% \triangleq M$									
Leakage current $I_L$ (5 min, 20 °C)	$I_L \leq 0,006 \mu A \cdot \left( \frac{C_R}{\mu F} \cdot \frac{U_R}{V} \right)^{0,7} + 4 \mu A$									
Self-inductance $ESL$	15 nH									
Useful life	<table border="1"> <tr> <td>40 °C; <math>U_R</math>; <math>2,1 \cdot I_{-R}</math></td> <td>&gt; 500 000 h</td> </tr> <tr> <td>85 °C; <math>U_R</math>; <math>2,1 \cdot I_{-R}</math></td> <td>&gt; 30 000 h</td> </tr> <tr> <td>125 °C; <math>U_R</math>; <math>I_{-R}</math></td> <td>&gt; 10 000 h</td> </tr> <tr> <td>150 °C; <math>U_R</math>; <math>0,5 \cdot I_{-R}</math></td> <td>&gt; 1 000 h</td> </tr> </table>	40 °C; $U_R$ ; $2,1 \cdot I_{-R}$	> 500 000 h	85 °C; $U_R$ ; $2,1 \cdot I_{-R}$	> 30 000 h	125 °C; $U_R$ ; $I_{-R}$	> 10 000 h	150 °C; $U_R$ ; $0,5 \cdot I_{-R}$	> 1 000 h	Requirements: $\Delta C/C \leq \pm 30 \%$ of initial value $ESR \leq 3$ times initial specified limit $I_L \leq$ initial specified limit Failure percentage: $\leq 0,5 \%$ Failure rate: $\leq 10$ fit ( $\leq 10 \cdot 10^{-9}/h$ ) (for definiton "fit", refer to chapter "Quality", page 62)
40 °C; $U_R$ ; $2,1 \cdot I_{-R}$	> 500 000 h									
85 °C; $U_R$ ; $2,1 \cdot I_{-R}$	> 30 000 h									
125 °C; $U_R$ ; $I_{-R}$	> 10 000 h									
150 °C; $U_R$ ; $0,5 \cdot I_{-R}$	> 1 000 h									
Voltage endurance test 125 °C; $U_R$	2000 h	Post test requirements: $\Delta C/C \leq \pm 10 \%$ of initial value $ESR \leq 1,3$ times initial specified limit $I_L \leq$ initial specified limit								
Vibration resistance	To IEC 60068-2-6, test Fc: displacement amplitude 0,75 mm, frequency range 10 Hz to 2 kHz, acceleration max. 10 g, duration $3 \times 2$ h Vibration resistance 20 g upon request									
IEC climatic category	To IEC 60068-1: 55/125/56 (– 55 °C/+ 125 °C/56 days damp heat test)									
Detail specification	Similar to CECC 30301-809									
Sectional specification	IEC 60384-4									

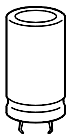

**B41607**

**Automotive – Up to 150 °C**

**Dimensional drawing**

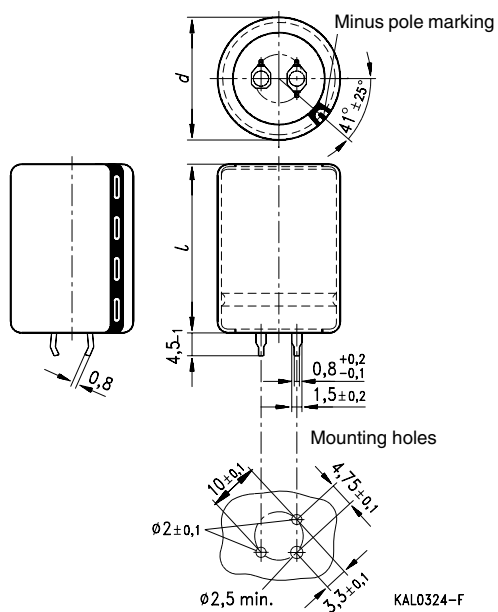

Dimensions (mm)		Approx. weight (g)	Packing units (pieces)
$d + 1$	$l \pm 2$		
22	40	18	160
25	40	22	130

**Packing of snap-in capacitors**



For ecological reasons the packing is pure cardboard. Components can be withdrawn (in full or in part) in the correct position for insertion.



B41607

Automotive – Up to 150 °C



**Overview of available types**

$U_R$ (VDC)	25	40	55	63
$C_R$ ( $\mu$ F)	Case dimensions $d \times l$ (mm)			
800				22 × 40
1 100			22 × 40	25 × 40
1 500		22 × 40	25 × 40	
2 000		25 × 40		
2 500	22 × 40			
3 300	25 × 40			

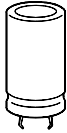

**B41607**

**Automotive – Up to 150 °C**

**Case dimensions and ordering codes**

$U_R$	$C_R$	Case dim. $d \times l$ mm	Ordering code
VDC	$\mu\text{F}$		3 terminals
25	2 500	22 × 40	B41607A4258M002
	3 300	25 × 40	B41607A4338M002
40	1 500	22 × 40	B41607A7158M002
	2 000	25 × 40	B41607A7208M002
55	1 100	22 × 40	B41607A0118M002
	1 500	25 × 40	B41607A0158M002
63	800	22 × 40	B41607A8807M002
	1 100	25 × 40	B41607A8118M002

**Technical data**

$C_R$	Case dim.	$ESR_{typ}$	$ESR_{max}$	$ESR_{max}$	$ESR_{max}$	$Z_{max}$	$I_{\sim max}$	$I_{\sim R}$	$I_{\sim max}$
100 Hz	$d \times l$	100 Hz	100 Hz	100 Hz	10 kHz	100 kHz	10 kHz	10 kHz	10 kHz
20 °C	mm	20 °C	20 °C	- 40 °C	20 °C	20 °C	105 °C	125 °C	150 °C
$\mu\text{F}$		$\text{m}\Omega$	$\text{m}\Omega$	$\text{m}\Omega$	$\text{m}\Omega$	$\text{m}\Omega$	A	A	A
<b>25 VDC</b>									
2 500	22 × 40	25	35	115	26	25	9,9	5,6	2,8
3 300	25 × 40	20	28	80	18	17	13,5	7,6	3,8
<b>40 VDC</b>									
1 500	22 × 40	35	48	115	26	25	9,8	5,5	2,7
2 000	25 × 40	26	36	80	18	17	13,4	7,6	3,8
<b>55 VDC</b>									
1 100	22 × 40	40	55	115	26	25	9,7	5,5	2,7
1 500	25 × 40	30	42	80	18	17	13,4	7,5	3,7
<b>63 VDC</b>									
800	22 × 40	45	62	115	26	25	9,6	5,4	2,7
1 100	25 × 40	32	45	80	18	17	13,3	7,4	3,7



**Useful life**

depending on ambient temperature  $T_A$  under ripple current operating conditions at  $U_R^{1)}$

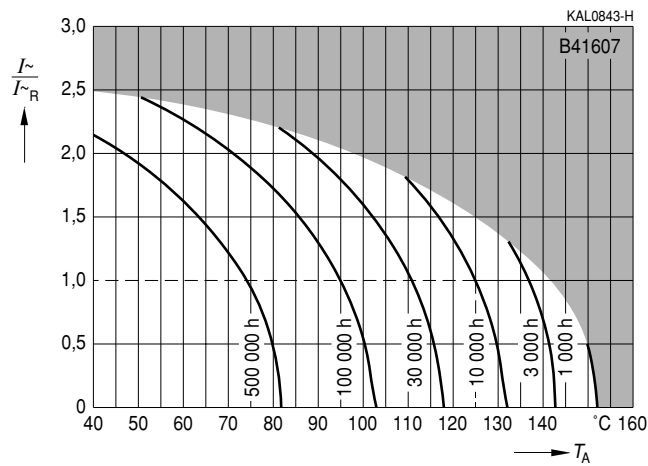

**Useful life**

depending on case temperature  $T_C$  under ripple current operating conditions at  $U_R^{1)}$

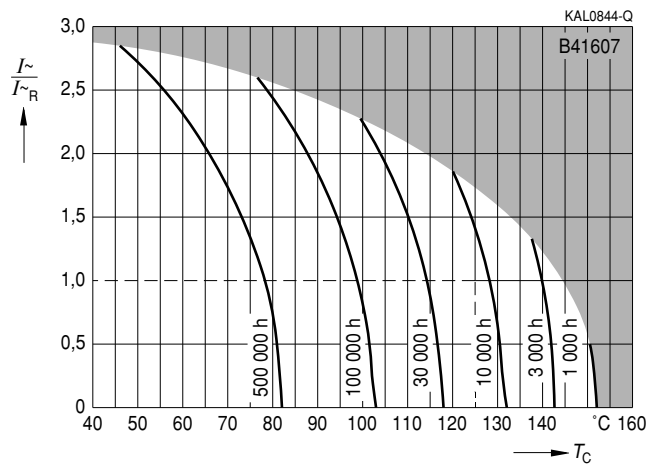

1) Refer to page 40 for an explanation on how to interpret the useful life graphs.

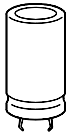

**B41607**

**Automotive – Up to 150 °C**

**Frequency factor of permissible ripple current  $I_r$  versus frequency  $f$**

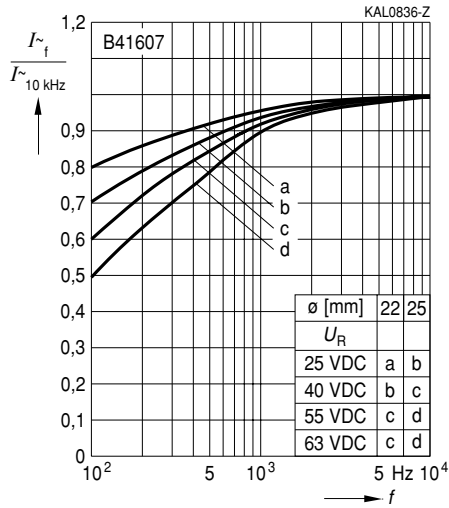

**Frequency characteristics of ESR versus frequency  $f$  at different temperatures  $T$**   
Typical behavior

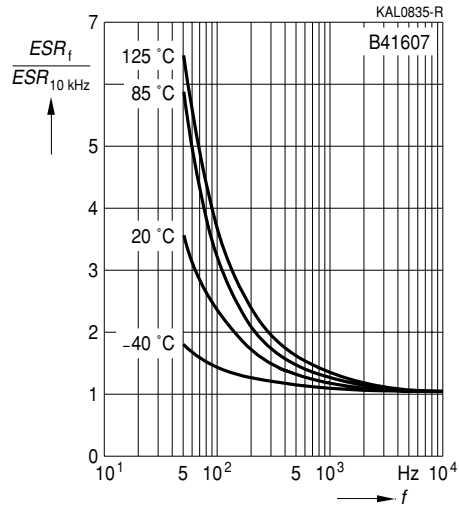

**Equivalent series resistance ESR versus frequency  $f$  at different temperatures  $T$**   
Typical behavior for 1500  $\mu$ F/55 V

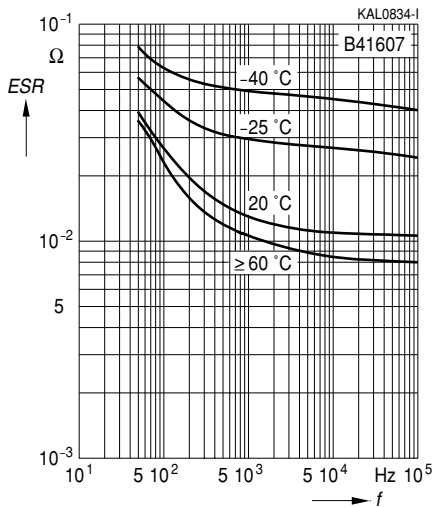

**Impedance Z versus frequency  $f$  at different temperatures  $T$**   
Typical behavior for 1500  $\mu$ F/55 V

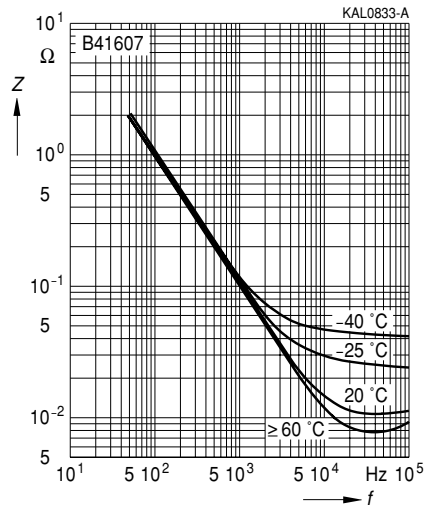

**Herausgegeben von EPCOS AG**

**Unternehmenskommunikation, Postfach 80 17 09, 81617 München, DEUTSCHLAND**

**☎ ++49 89 636 09, FAX (0 89) 636-2 26 89**

© EPCOS AG 2002. Vervielfältigung, Veröffentlichung, Verbreitung und Verwertung dieser Broschüre und ihres Inhalts ohne ausdrückliche Genehmigung der EPCOS AG nicht gestattet.

Bestellungen unterliegen den vom ZVEI empfohlenen Allgemeinen Lieferbedingungen für Erzeugnisse und Leistungen der Elektroindustrie, soweit nichts anderes vereinbart wird.

Diese Broschüre ersetzt die vorige Ausgabe.

Fragen über Technik, Preise und Liefermöglichkeiten richten Sie bitte an den Ihnen nächstgelegenen Vertrieb der EPCOS AG oder an unsere Vertriebsgesellschaften im Ausland. Bauelemente können aufgrund technischer Erfordernisse Gefahrstoffe enthalten. Auskünfte darüber bitten wir unter Angabe des betreffenden Typs ebenfalls über die zuständige Vertriebsgesellschaft einzuholen.

**Published by EPCOS AG**

**Corporate Communications, P.O. Box 80 17 09, 81617 Munich, GERMANY**

**☎ ++49 89 636 09, FAX (0 89) 636-2 26 89**

© EPCOS AG 2002. Reproduction, publication and dissemination of this brochure and the information contained therein without EPCOS' prior express consent is prohibited.

Purchase orders are subject to the General Conditions for the Supply of Products and Services of the Electrical and Electronics Industry recommended by the ZVEI (German Electrical and Electronic Manufacturers' Association), unless otherwise agreed.

This brochure replaces the previous edition.

For questions on technology, prices and delivery please contact the Sales Offices of EPCOS AG or the international Representatives.

Due to technical requirements components may contain dangerous substances. For information on the type in question please also contact one of our Sales Offices.