



# Multiformat SDTV Video Decoder with Fast Switch Overlay Support

## ADV7184

### FEATURES

- Multiformat video decoder supports NTSC-(J, M, 4.43), PAL-(B/D/G/H/I/M/N), SECAM
- Integrates four 54 MHz, 10-bit ADCs
- SCART fast blank support
- Clocked from a single 28.63636 MHz crystal
- Line-locked clock-compatible (LLC)
- Adaptive digital line length tracking (ADLLT™), signal processing, and enhanced FIFO management give mini TBC functionality
- 5-line adaptive comb filters
- Proprietary architecture for locking to weak, noisy, and unstable video sources such as VCRs and tuners
- Subcarrier frequency lock and status information output
- Integrated AGC with adaptive peak white mode
- Macrovision® copy protection detection
- CTI (chroma transient improvement)
- DNR (digital noise reduction)
- Multiple programmable analog input formats
  - CVBS (composite video)
  - S-Video (Y/C)
  - YPrPb component (VESA, MII, SMPTE, and Betacam)
- 12 analog video input channels
- Integrated antialiasing filters
- Automatic NTSC/PAL/SECAM identification
- Programmable interrupt request output pin

### GENERAL DESCRIPTION

The ADV7184 integrated video decoder automatically detects and converts a standard analog baseband television signal, which is compatible with worldwide standards NTSC, PAL, and SECAM, into 4:2:2 component video data-compatible with 16-bit or 8-bit CCIR601/CCIR656.

The advanced and highly flexible digital output interface enables performance video decoding and conversion in line-locked clock-based systems. This makes the device ideally suited for a broad range of applications with diverse analog video characteristics, including tape-based sources, broadcast sources, security and surveillance cameras, and professional systems.

The 10-bit accurate ADC provides professional quality video performance and is unmatched. This allows true 8-bit resolution in the 8-bit output mode.

The 12 analog input channels accept standard composite, S-Video, and YPrPb video signals in an extensive number of combinations.

- Digital output formats (8-bit or 16-bit)
  - ITU-R BT.656 YCrCb 4:2:2 output + HS, VS, and FIELD 0.5 V to 1.6 V analog signal input range
- Differential gain: 0.5% typ
- Differential phase: 0.5° typ
- Programmable video controls
  - Peak white/hue/brightness/saturation/contrast
- Integrated on-chip video timing generator
- Free-run mode (generates stable video output with no I/P)
- VBI decode support for closed captioning (including XDS), WSS, CGMS, Gemstar® 1x/2x, Teletext, VITC, VPS
- Power-down mode
- 2-wire serial MPU interface (I<sup>2</sup>C-compatible)
- 3.3 V analog, 1.8 V digital core; 3.3 V IO supply
- Industrial temperature grade: -40°C to +85°C
- 80-lead LQFP Pb-free package

### APPLICATIONS

- DVD recorders
- Video projectors
- HDD-based PVRs/DVDRs
- LCD TVs
- Set-top boxes
- Security systems
- Digital televisions
- AVR receivers

AGC and clamp restore circuitry allow an input video signal peak-to-peak range of 0.5 V to 1.6 V. Alternatively, these can be bypassed for manual settings.

The fixed 54 MHz clocking of the ADCs and datapath for all modes allows very precise, accurate sampling and digital filtering. The line locked clock output allows the output data rate, timing signals, and output clock signals to be synchronous, asynchronous, or line locked even with ±5% line length variation. The output control signals allow glueless interface connections in almost any application. The ADV7184 modes are set up over a 2-wire, serial, bidirectional port (I<sup>2</sup>C-compatible).

SCART and overlay functionality are enabled by the ADV7184's ability to simultaneously process CVBS and standard definition RGB signals. Signal mixing is controlled by the fast blank pin.

The ADV7184 is fabricated in a 3.3 V CMOS process. Its monolithic CMOS construction ensures greater functionality with lower power dissipation. The ADV7184 is packaged in a small 80-lead LQFP Pb-free package.

## TABLE OF CONTENTS

Introduction .....	4	VBI Data Recovery.....	23
Analog Front End.....	4	General Setup.....	23
Standard Definition Processor (SDP).....	4	Color Controls.....	25
Electrical Characteristics .....	5	Clamp Operation.....	27
Video Specifications.....	6	Luma Filter .....	28
Timing Specifications .....	7	Chroma Filter.....	31
Analog Specifications.....	7	Gain Operation.....	31
Thermal Specifications .....	8	Chroma Transient Improvement (CTI) .....	34
Timing Diagrams.....	8	Digital Noise Reduction (DNR), and Luma Peaking Filter ..	35
Absolute Maximum Ratings.....	9	Comb Filters.....	36
Package Thermal Performance.....	9	AV Code Insertion and Controls .....	39
ESD Caution.....	9	Synchronization Output Signals.....	40
Pin Configuration and Function Descriptions.....	10	Sync Processing .....	48
Analog Front End .....	12	VBI Data Decode .....	48
Analog Input Muxing .....	12	I <sup>2</sup> C Readback registers .....	57
Manual Input Muxing.....	14	Pixel Port Configuration .....	71
XTAL Clock Input Pin Functionality.....	15	MPU Port Description.....	72
28.63636 MHz Crystal Operation .....	15	Register Accesses.....	73
Antialiasing Filters .....	15	Register Programming.....	73
SCART and Fast Blanking.....	15	I <sup>2</sup> C Sequencer.....	73
Fast Blank Control.....	16	I <sup>2</sup> C Register Maps .....	74
Readback of FB Pin Status.....	18	User Map .....	74
Global Control Registers .....	19	User Sub Map.....	90
Power-Save Modes.....	19	I <sup>2</sup> C Programming Examples.....	99
Reset Control .....	19	Mode 1 CVBS Input.....	99
Global Pin Control.....	19	Mode 2 S-Video Input .....	100
Global Status Registers.....	21	Mode 3 525i/625i YPrPb Input .....	101
Standard Definition Processor (SDP).....	22	Mode 4 SCART—S-Video or CVBS Autodetect.....	102
SD Luma Path .....	22	Mode 5 SCART Fast Blank—CVBS and RGB.....	103
SD Chroma Path.....	22	Mode 6 SCART RGB input (Static Fast Blank)—CVBS and RGB .....	104
Sync Processing.....	23		

PCB Layout Recommendations .....	105	Digital Inputs.....	106
Analog Interface Inputs.....	105	XTAL And Load Capacitor Values Selection .....	106
Power Supply Decoupling.....	105	Typical Circuit Connection .....	107
PLL .....	105	Outline Dimensions.....	108
Digital Outputs (Both Data and Clocks) .....	105	Ordering Guide .....	108

**REVISION HISTORY**

**7/05—Revision 0: Initial Version**

# ADV7184

## INTRODUCTION

The ADV7184 is a high quality, single chip, multiformat video decoder that automatically detects and converts PAL, NTSC, and SECAM standards in the form of composite, S-Video, and component video into a digital ITU-R BT.656 format.

The advanced and highly flexible digital output interface enables performance video decoding and conversion in line-locked clock-based systems. This makes the device ideally suited for a broad range of applications with diverse analog video characteristics, including tape-based sources, broadcast sources, security and surveillance cameras, and professional systems.

### ANALOG FRONT END

The ADV7184 analog front end includes four 10-bit ADCs that digitize the analog video signal before applying it to the standard definition processor. The analog front end uses differential channels to each ADC to ensure high performance in mixed-signal applications.

The front end also includes a 12-channel input mux that enables multiple video signals to be applied to the ADV7184. Current and voltage clamps are positioned in front of each ADC to ensure that the video signal remains within the range of the converter. Fine clamping of the video signals is performed downstream by digital fine clamping within the ADV7184. The ADCs are configured to run in 4x oversampling mode.

The ADV7184 has optional antialiasing filters on each of the four input channels. The filters are designed for SD video with approximately 6 MHz bandwidth.

SCART and overlay functionality are enabled by the ADV7184's ability to simultaneously process CVBS and Standard Definition RGB signals. Signal mixing is controlled by the Fast Blank pin.

### STANDARD DEFINITION PROCESSOR (SDP)

The ADV7184 is capable of decoding a large selection of baseband video signals in composite, S-Video, and component formats. The video standards supported include PAL B/D/I/G/H, PAL60, PAL M, PAL N, PAL Nc, NTSC M/J, NTSC 4.43, and SECAM B/D/G/K/L. The ADV7184 can automatically detect the video standard and process it accordingly.

The ADV7184 has a 5-line, superadaptive, 2D comb filter that gives superior chrominance and luminance separation when decoding a composite video signal. This highly adaptive filter automatically adjusts its processing mode according to video standard and signal quality without user intervention. Video user controls such as brightness, contrast, saturation, and hue are also available within the ADV7184.

The ADV7184 implements a patented adaptive digital line-length tracking (ADLLT) algorithm to track varying video line lengths from sources such as a VCR. ADLLT enables the ADV7184 to track and decode poor quality video sources such as VCRs, noisy sources from tuner outputs, VCD players, and camcorders. The ADV7184 contains a chroma transient improvement (CTI) processor that sharpens the edge rate of chroma transitions, resulting in sharper vertical transitions.

The ADV7184 can process a variety of VBI data services, such as closed captioning (CC), wide screen signaling (WSS), copy generation management system (CGMS), Gemstar 1x/2x, extended data service (XDS), and teletext. The ADV7184 is fully Macrovision certified; detection circuitry enables Type I, II, and III protection levels to be identified and reported to the user. The decoder is also fully robust to all Macrovision signal inputs.

## FUNCTIONAL BLOCK DIAGRAM

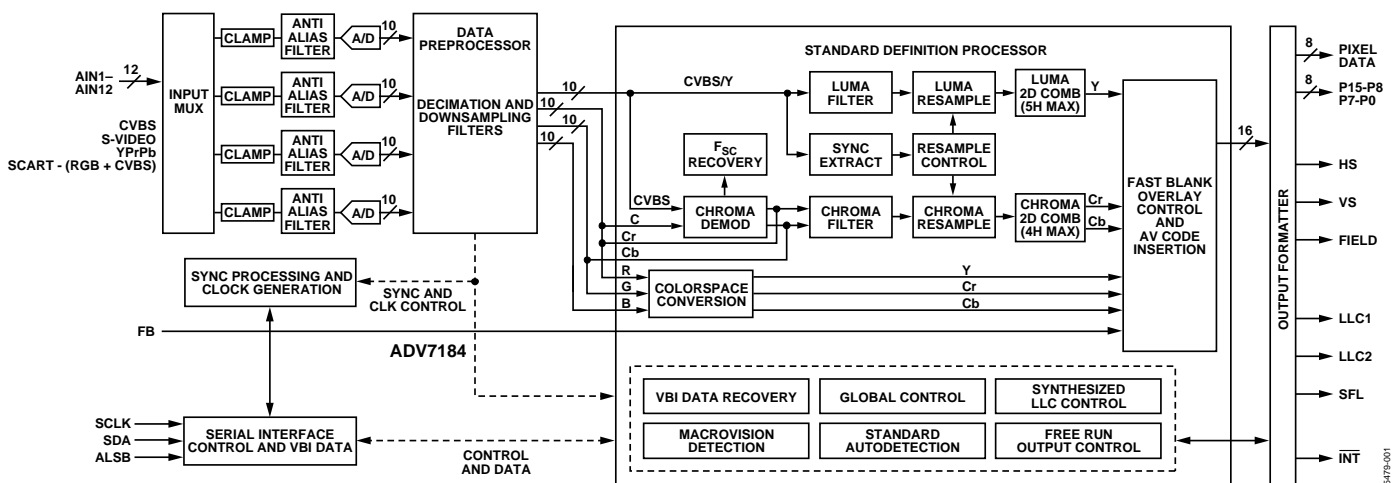

Figure 1.

## ELECTRICAL CHARACTERISTICS

At  $A_{VDD} = 3.15\text{ V to }3.45\text{ V}$ ,  $D_{VDD} = 1.65\text{ V to }2.0\text{ V}$ ,  $D_{VDDIO} = 3.0\text{ V to }3.6\text{ V}$ ,  $P_{VDD} = 1.71\text{ V to }1.89\text{ V}$ , nominal input range 1.6 V.  
Operating temperature range, unless otherwise noted.

Table 1.

Parameter	Symbol	Test Conditions	Min	Typ	Max	Unit
STATIC PERFORMANCE <sup>1, 2, 3</sup>						
Resolution (Each ADC)	N				10	Bits
Integral Nonlinearity	INL	BSL at 54 MHz		-0.6/+0.7	±3	LSB
Differential Nonlinearity	DNL	BSL at 54 MHz		-0.5/+0.5	-0.99/2.5	LSB
DIGITAL INPUTS						
Input High Voltage <sup>4</sup>	$V_{IH}$		2			V
Input Low Voltage <sup>5</sup>	$V_{IL}$				0.8	V
Input Current	$I_{IN}$	Pins listed in Note 6 All other pins <sup>7</sup>	-50		+50	μA
			-10		+10	μA
Input Capacitance <sup>9</sup>	$C_{IN}$				10	pF
DIGITAL OUTPUTS						
Output High Voltage <sup>8</sup>	$V_{OH}$	$I_{SOURCE} = 0.4\text{ mA}$	2.4			V
Output Low Voltage <sup>8</sup>	$V_{OL}$	$I_{SINK} = 3.2\text{ mA}$			0.4	V
High Impedance Leakage Current	$I_{LEAK}$				10	μA
Output Capacitance <sup>9</sup>	$C_{OUT}$				20	pF
POWER REQUIREMENTS <sup>9</sup>						
Digital Core Power Supply	$D_{VDD}$		1.65	1.8	2	V
Digital I/O Power Supply	$D_{VDDIO}$		3.0	3.3	3.6	V
PLL Power Supply	$P_{VDD}$		1.71	1.8	1.89	V
Analog Power Supply	$A_{VDD}$		3.15	3.3	3.45	V
Digital Core Supply Current	$I_{DVDD}$			105		mA
Digital I/O Supply Current	$I_{DVDDIO}$			4		mA
PLL Supply Current	$I_{PVDD}$			11		mA
Analog Supply Current	$I_{AVDD}$	CVBS input <sup>10</sup> YPrPb input <sup>11</sup>		99		mA
				269		mA
Power-Down Current	$I_{PWRDN}$			0.65		mA
Power-Up Time	$t_{PWRUP}$			20		ms

<sup>1</sup> All ADC linearity tests performed at input range of full scale - 12.5%, and at zero scale +12.5%.

<sup>2</sup> Max INL and DNL specifications obtained with part configured for component video input.

<sup>3</sup> Temperature range  $T_{MIN}$  to  $T_{MAX}$ , -40°C to +85°C. The min/max specifications are guaranteed over this range.

<sup>4</sup> To obtain specified  $V_{IH}$  level on Pin 29, Register 0x13 (write only) must be programmed with value 0x04. If Register 0x13 is programmed with value 0x00, then  $V_{IH}$  on Pin 29 = 1.2 V.

<sup>5</sup> To obtain specified  $V_{IL}$  level on Pin 29, Register 0x13 (write only) must be programmed with value 0x04. If Register 0x13 is programmed with value 0x00, then  $V_{IL}$  on Pin 29 = 0.4 V.

<sup>6</sup> Pins: 36 and 79.

<sup>7</sup> Excluding all "TEST" pins (TEST0 to TEST12)

<sup>8</sup>  $V_{OH}$  and  $V_{OL}$  levels obtained using default drive strength value (0xD5) in register subaddress 0xF4.

<sup>9</sup> Guaranteed by characterization.

<sup>10</sup> ADC0 powered on only.

<sup>11</sup> All four ADCs powered on.

# ADV7184

## VIDEO SPECIFICATIONS

At  $A_{VDD} = 3.15 \text{ V to } 3.45 \text{ V}$ ,  $D_{VDD} = 1.65 \text{ V to } 2.0 \text{ V}$ ,  $D_{VDDIO} = 3.0 \text{ V to } 3.6 \text{ V}$ ,  $P_{VDD} = 1.71 \text{ V to } 1.89 \text{ V}$ . Operating temperature range, unless otherwise noted.

**Table 2.**

Parameter <sup>1,2</sup>	Symbol	Test Conditions	Min	Typ	Max	Unit
<b>NONLINEAR SPECIFICATIONS</b>						
Differential Phase	DP	CVBS I/P, modulate 5-step		0.5	0.7	Degree
Differential Gain	DG	CVBS I/P, modulate 5-step		0.5	0.7	%
Luma Nonlinearity	LNL	CVBS I/P, 5-step		0.5	0.7	%
<b>NOISE SPECIFICATIONS</b>						
SNR Unweighted		Luma ramp	54	56		dB
		Luma flat field	56	58		dB
Analog Front End Crosstalk				60		dB
<b>LOCK TIME SPECIFICATIONS</b>						
Horizontal Lock Range			-5		+5	%
Vertical Lock Range			40		70	Hz
Fsc Subcarrier Lock Range				±1.3		Hz
Color Lock In Time				60		Lines
Sync Depth Range <sup>3</sup>			20		200	%
Color Burst Range			5		200	%
Vertical Lock Time				2		Fields
Autodetection Switch Speed				100		Lines
<b>CHROMA SPECIFICATIONS</b>						
Hue Accuracy	HUE			1		Degree
Color Saturation Accuracy	CL_AC			1		%
Color AGC Range			5		400	%
Chroma Amplitude Error				0.5		%
Chroma Phase Error				0.4		Degree
Chroma Luma Intermodulation				0.2		%
<b>LUMA SPECIFICATIONS</b>						
Luma Brightness Accuracy		CVBS, 1 V I/P		1		%
Luma Contrast Accuracy		CVBS, 1 V I/P		1		%

<sup>1</sup> Temperature range  $T_{MIN}$  to  $T_{MAX}$ ,  $-40^{\circ}\text{C}$  to  $+85^{\circ}\text{C}$ . The min/max specifications are guaranteed over this range.

<sup>2</sup> Guaranteed by characterization.

<sup>3</sup> Nominal sync depth is 300 mV at 100% sync depth range.

## TIMING SPECIFICATIONS

At  $A_{VDD} = 3.15\text{ V to }3.45\text{ V}$ ,  $D_{VDD} = 1.65\text{ V to }2.0\text{ V}$ ,  $D_{VDDIO} = 3.0\text{ V to }3.6\text{ V}$ ,  $P_{VDD} = 1.71\text{ V to }1.89\text{ V}$ . Operating temperature range, unless otherwise noted.

Table 3.

Parameter <sup>1,2</sup>	Symbol	Test Conditions	Min	Typ	Max	Unit
SYSTEM CLOCK AND CRYSTAL						
Nominal Frequency				28.63636		MHz
Frequency Stability					±50	ppm
I <sup>2</sup> C PORT <sup>3</sup>						
SCLK Frequency					400	kHz
SCLK Min Pulse Width High	t <sub>1</sub>		0.6			μs
SCLK Min Pulse Width Low	t <sub>2</sub>		1.3			μs
Hold Time (Start Condition)	t <sub>3</sub>		0.6			μs
Setup Time (Start Condition)	t <sub>4</sub>		0.6			μs
SDA Setup Time	t <sub>5</sub>		100			ns
SCLK and SDA Rise Time	t <sub>6</sub>				300	ns
SCLK and SDA Fall Time	t <sub>7</sub>				300	ns
Setup Time for Stop Condition	t <sub>8</sub>			0.6		μs
RESET FEATURE						
Reset Pulse Width			5			ms
CLOCK OUTPUTS						
LLC1 Mark Space Ratio	t <sub>9</sub> :t <sub>10</sub>		45:55		55:45	% duty cycle
LLC1 Rising to LLC2 Rising	t <sub>11</sub>			1		ns
LLC1 Rising to LLC2 Falling	t <sub>12</sub>			1		ns
DATA AND CONTROL OUTPUTS						
Data Output Transitional Time <sup>4</sup>	t <sub>13</sub>	Negative clock edge to start of valid data; (t <sub>ACCESS</sub> = t <sub>10</sub> - t <sub>13</sub> )			3.6	ns
Data Output Transitional Time <sup>4</sup>	t <sub>14</sub>	End of valid data to negative clock edge; (t <sub>HOLD</sub> = t <sub>9</sub> + t <sub>14</sub> )			2.4	ns
Propagation Delay to Hi-Z	t <sub>15</sub>			6		ns
Max Output Enable Access Time	t <sub>16</sub>			7		ns
Min Output Enable Access Time	t <sub>17</sub>			4		ns

<sup>1</sup> Temperature range T<sub>MIN</sub> to T<sub>MAX</sub>, -40°C to +85°C. The min/max specifications are guaranteed over this range.

<sup>2</sup> Guaranteed by characterization.

<sup>3</sup> TTL input values are 0 V to 3 V, with rise/fall times ≤ 3 ns, measured between the 10% and 90% points.

<sup>4</sup> Timing figures obtained using default drive strength value (0xD5) in register subaddress 0xF4.

## ANALOG SPECIFICATIONS

At  $A_{VDD} = 3.15\text{ V to }3.45\text{ V}$ ,  $D_{VDD} = 1.65\text{ V to }2.0\text{ V}$ ,  $D_{VDDIO} = 3.0\text{ V to }3.6\text{ V}$ ,  $P_{VDD} = 1.71\text{ V to }1.89\text{ V}$ . Operating temperature range, unless otherwise noted. Recommended analog input video signal range: 0.5 V to 1.6 V, typically 1 V p-p.

Table 4.

Parameter <sup>1,2</sup>	Symbol	Test Conditions	Min	Typ	Max	Unit
CLAMP CIRCUITRY						
External Clamp Capacitor				0.1		μF
Input Impedance <sup>3</sup>		Clamps switched off		10		MΩ
Input impedance of Pin 40 (FB)				20		kΩ
Large Clamp Source Current				0.75		mA
Large Clamp Sink Current				0.75		mA
Fine Clamp Source Current				17		μA
Fine Clamp Sink Current				17		μA

<sup>1</sup> Temperature range T<sub>MIN</sub> to T<sub>MAX</sub>, -40°C to +85°C. The min/max specifications are guaranteed over this range.

<sup>2</sup> Guaranteed by characterization.

<sup>3</sup> Except Pin 40 (FB).

# ADV7184

## THERMAL SPECIFICATIONS

Table 5.

Parameter	Symbol	Test Conditions	Min	Typ	Max	Unit
Junction-to-Case Thermal Resistance	$\theta_{JC}$	4-layer PCB with solid ground plane		7.6		$^{\circ}\text{C}/\text{W}$
Junction-to-Ambient Thermal Resistance (Still Air)	$\theta_{JA}$	4-layer PCB with solid ground plane		38.1		$^{\circ}\text{C}/\text{W}$

## TIMING DIAGRAMS

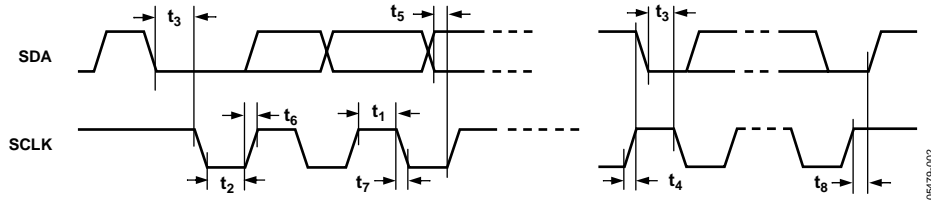

Figure 2. I<sup>2</sup>C Timing

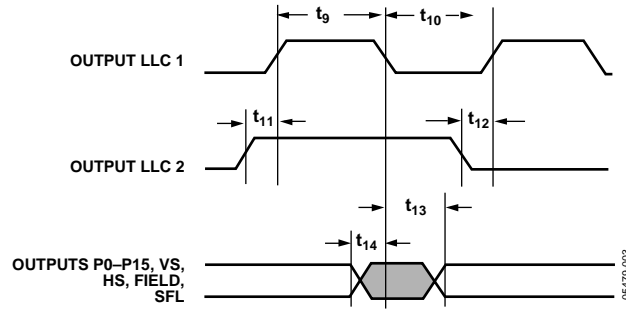

Figure 3. Pixel Port and Control Output Timing

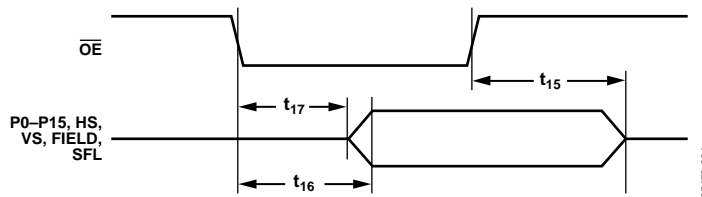

Figure 4.  $\overline{\text{OE}}$  Timing

## ABSOLUTE MAXIMUM RATINGS

Table 6.

Parameter	Rating
$A_{VDD}$ to AGND	4 V
$D_{VDD}$ to DGND	2.2 V
$P_{VDD}$ to AGND	2.2 V
$D_{VDDIO}$ to DGND	4 V
$D_{VDDIO}$ to $A_{VDD}$	-0.3 V to +0.3 V
$P_{VDD}$ to $D_{VDD}$	-0.3 V to +0.3 V
$D_{VDDIO}$ to $P_{VDD}$	-0.3V to +2 V
$D_{VDDIO}$ to $D_{VDD}$	-0.3V to +2 V
$A_{VDD}$ to $P_{VDD}$	-0.3V to +2 V
$A_{VDD}$ to $D_{VDD}$	-0.3V to +2 V
Digital Inputs Voltage to DGND	-0.3V to $D_{VDDIO} + 0.3$ V
Digital Output Voltage to DGND	-0.3V to $D_{VDDIO} + 0.3$ V
Analog Inputs to AGND	AGND - 0.3 V to $A_{VDD} + 0.3$ V
Maximum Junction Temperature ( $T_j$ max)	125°C
Storage Temperature Range	-65°C to +150°C
Infrared Reflow Soldering (20 sec)	260°C

Stresses above those listed under Absolute Maximum Ratings may cause permanent damage to the device. This is a stress rating only; functional operation of the device at these or any other conditions above those indicated in the operational section of this specification is not implied. Exposure to absolute maximum rating conditions for extended periods may affect device reliability.

### PACKAGE THERMAL PERFORMANCE

To reduce power consumption the user is advised to turn off any unused ADCs when using the part.

The junction temperature must always stay below the maximum junction temperature ( $T_j$  max) of 125°C. The following equation shows how to calculate the junction temperature:

$$T_j = T_{A\ Max} + (\theta_{JA} \times W_{Max})$$

where:

$$T_{A\ Max} = 85^\circ\text{C}.$$

$$\theta_{JA} = 30^\circ\text{C/W}.$$

$$W_{max} = ((A_{VDD} \times I_{AVDD}) + (D_{VDD} \times I_{DVDD}) + (D_{VDDIO} \times I_{DVDDIO}) + (P_{VDD} \times I_{PVDD})).$$

### ESD CAUTION

ESD (electrostatic discharge) sensitive device. Electrostatic charges as high as 4000 V readily accumulate on the human body and test equipment and can discharge without detection. Although this product features proprietary ESD protection circuitry, permanent damage may occur on devices subjected to high energy electrostatic discharges. Therefore, proper ESD precautions are recommended to avoid performance degradation or loss of functionality.



# ADV7184

## PIN CONFIGURATION AND FUNCTION DESCRIPTIONS

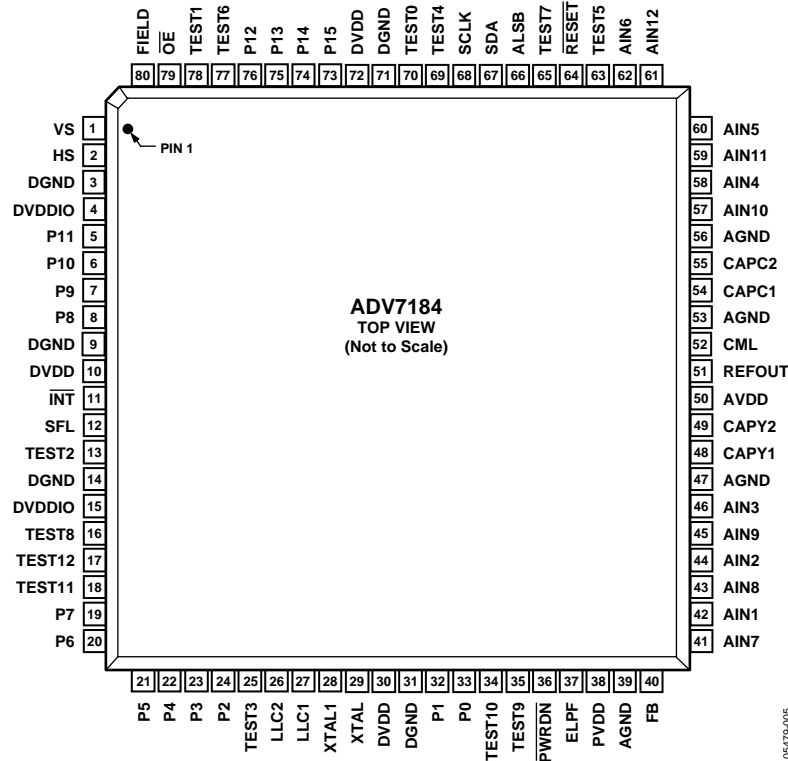

Figure 5. 80-Lead LQFP Pin Configuration

Table 7. Pin Function Descriptions

Pin No.	Mnemonic	Type	Function
3, 9, 14, 31, 71	DGND	G	Digital Ground.
39, 47, 53, 56	AGND	G	Analog Ground.
4, 15	DVDDIO	P	Digital I/O Supply Voltage (3.3 V).
10, 30, 72	DVDD	P	Digital Core Supply Voltage (1.8 V).
50	AVDD	P	Analog Supply Voltage (3.3 V).
38	PVDD	P	PLL Supply Voltage (1.8 V).
42, 44, 46, 58, 60, 62, 41, 43, 45, 57, 59, 61	AIN1 to AIN12	I	Analog Video Input Channels.
11	$\overline{\text{INT}}$	O	Interrupt Request Output. Interrupt occurs when certain signals are detected on the input video. See the User Sub Map register details in Table 103.
40	FB	I	Fast Blank. FB is a fast switch overlay input that switches between CVBS and RGB analog I/P signals.
70, 78, 13, 25, 69, 63, 35, 34, 18, 17	TEST0 to TEST5, TEST9 to TEST12		Leave these pins unconnected.
77, 65	TEST6 to TEST7		Tie to AGND
16	TEST8		Tie to DVDDIO
33, 32, 24, 23, 22, 21, 20, 19, 8, 7, 6, 5, 76, 75, 74, 73	P0 to P15	O	Video Pixel Output Port.
2	HS	O	Horizontal Synchronization Output Signal.
1	VS	O	Vertical Synchronization Output Signal.
80	FIELD	O	Field Synchronization Output Signal.

Pin No.	Mnemonic	Type	Function
67	SDA	I/O	I <sup>2</sup> C Port Serial Data Input/Output Pin.
68	SCLK	I	I <sup>2</sup> C Port Serial Clock Input (Max Clock Rate of 400 kHz).
66	ALSB	I	This pin selects the I <sup>2</sup> C address for the ADV7184. ALSB set to Logic 0 sets the address for a write as 0x40; set to Logic 1 sets the address as 0x42.
64	$\overline{\text{RESET}}$	I	System Reset Input, Active Low. A minimum low reset pulse width of 5 ms is required to reset the ADV7184 circuitry.
27	LLC1	O	Line-Locked Clock 1. Line-locked output clock for the pixel data output by the ADV7184. Nominally 27 MHz, but varies up or down according to video line length.
26	LLC2	O	Line-Locked Clock 2. This is a divide-by-2 version of the LLC1 output clock for the pixel data output by the ADV7184. Nominally 13.5 MHz, but varies up or down according to video line length.
29	XTAL	I	This is the input pin for the 28.63636 MHz crystal, or can be overdriven by an external 3.3 V, 28.63636 MHz clock oscillator source. In crystal mode, the crystal must be a fundamental crystal.
28	XTAL1	O	This pin should be connected to the 28.63636 MHz crystal or left as a no connect if an external 3.3 V, 28.63636 MHz clock oscillator source is used to clock the ADV7184. In crystal mode, the crystal must be a fundamental crystal.
36	$\overline{\text{PWRDN}}$	I	Logic 0 on this pin places the ADV7184 in a power-down mode. Refer to the I <sup>2</sup> C Register Maps section for more options on power-down modes for the ADV7184.
79	$\overline{\text{OE}}$	I	When set to Logic 0, $\overline{\text{OE}}$ enables the pixel output bus, P15 to P0 of the ADV7184. Logic 1 on the $\overline{\text{OE}}$ pin places P15 through P0, HS, VS, and SFL/SYNC_OUT into a high impedance state.
37	ELPF	I	The recommended external loop filter must be connected to this ELPF pin, as shown in Figure 50.
12	SFL	O	Subcarrier Frequency Lock. This pin contains a serial output stream that can be used to lock the subcarrier frequency when this decoder is connected to any Analog Devices, Inc. digital video encoder.
51	REFOUT	O	Internal Voltage Reference Output. Refer to Figure 50 for a recommended capacitor network for this pin.
52	CML	O	The CML pin is a common-mode level for the internal ADCs. Refer to Figure 50 for a recommended capacitor network for this pin.
48, 49	CAPY1, CAPY2	I	ADC's Capacitor Network. Refer to Figure 50 for a recommended capacitor network for these pins.
54, 55	CAPC1, CAPC2	I	ADC's Capacitor Network. Refer to Figure 50 for a recommended capacitor network for these pins.

## ANALOG FRONT END ANALOG INPUT MUXING

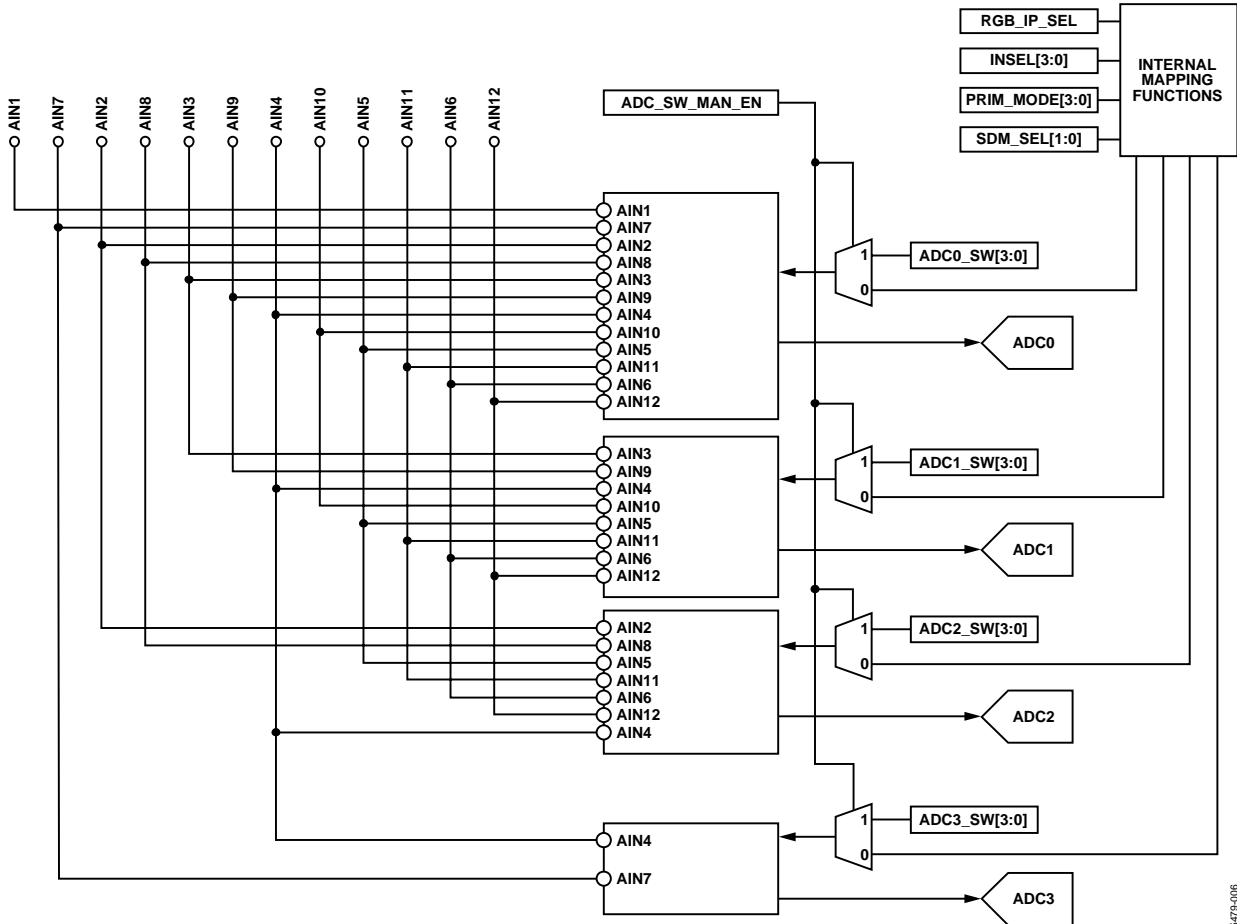

Figure 6. Internal Pin Connections

The ADV7184 has an integrated analog muxing section that allows connecting more than one source of video signal to the decoder. Figure 6 outlines the overall structure of the input muxing provided in the ADV7184. As seen in Figure 6, the analog input muxes can be controlled in two ways:

- By functional registers (INSEL). Using INSEL[3:0] simplifies the setup of the muxes, and minimizes crosstalk between channels by pre-assigning the input channels. This is referred to as ADI-recommended input muxing.
- By an I<sup>2</sup>C manual override (ADC\_SW\_MAN\_EN, ADC0\_SW, ADC1\_SW, ADC2\_SW, ADC3\_SW). This is provided for applications with special requirements, such as number/combinations of signals, which would not be served by the pre-assigned input connections. This is referred to as manual input muxing.

Refer to Figure 7 for an overview of the two methods of controlling input muxing.

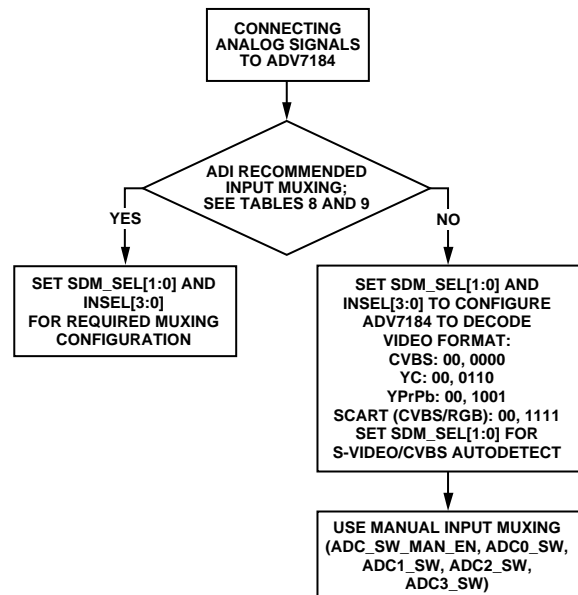

Figure 7. Input Muxing Overview

**ADI Recommended Input Muxing**

A maximum of 12 CVBS inputs can be connected and decoded by the ADV7184. As seen in Figure 5, this means the sources must be connected to adjacent pins on the IC. This calls for a careful design of the PCB layout, for example, ground shielding between all signals routed through tracks that are physically close together.

**SDM\_SEL[1:0], S-Video and CVBS Autodetect Mode Select, Address 0x69 [1:0]**

The SDM\_SEL bits decide on input routing and whether INSEL[3:0] is used to govern I/P routing decision.

The CVBS/YC autodetection feature is enabled using SDM\_SEL = 11.

**Table 8. SDM\_SEL[1:0]**

SDM_SEL[1:0]	Mode	Analogue Video Inputs
00	As per INSEL[3:0]	As per INSEL[3:0]
01	CVBS	AIN11
10	YC	Y = AIN10 C = AIN12
11	YC/CVBS auto	CVBS = AIN11 Y = AIN11 C = AIN12

**Table 9. Input Channel Switching Using INSEL[3:0]**

INSEL[3:0]	Description	
	Analog Input Pins	Video Format
0000 (default)	CVBS1 = AIN1 B = AIN4 or AIN7 <sup>1</sup> R = AIN5 or AIN8 <sup>1</sup> G = AIN6 or AIN9 <sup>1</sup>	SCART (CVBS and R, G, B)
0001	CVBS2 = AIN2 B = AIN4 or AIN7 <sup>1</sup> R = AIN5 or AIN8 <sup>1</sup> G = AIN6 or AIN9 <sup>1</sup>	SCART (CVBS and R, G, B)
0010	CVBS3 = AIN3 B = AIN4 or AIN7 <sup>1</sup> R = AIN5 or AIN8 <sup>1</sup> G = AIN6 or AIN9 <sup>1</sup>	SCART (CVBS and R, G, B)
0011	CVBS4 = AIN4 B = AIN7 R = AIN8 G = AIN9	SCART (CVBS and R, G, B)
0100	CVBS1 = AIN5 B = AIN7 R = AIN8 G = AIN9	SCART (CVBS and R, G, B)
0101	CVBS1 = AIN6 B = AIN7 R = AIN8 G = AIN9	SCART (CVBS and R, G, B)
0110	Y1 = AIN1 C1 = AIN4	YC
0111	Y2 = AIN2 C2 = AIN5	YC

**INSEL[3:0] Input Selection, Address 0x00 [3:0]**

The INSEL bits allow the user to select an input channel as well as the input format. Depending on the PCB connections, only a subset of the INSEL modes is valid. The INSEL[3:0] not only switches the analog input muxing, it also configures the standard definition processor core to process CVBS (Comp), S-Video (Y/C), or component (YPbPr/RGB) format.

ADI-recommended input muxing is designed to minimize crosstalk between signal channels and to obtain the highest level of signal integrity. Table 10 summarizes how the PCB layout should connect analog video signals to the ADV7184.

It is strongly recommended to connect any unused analog input pins to AGND to act as a shield.

Connect inputs AIN7 to AIN11 to AGND when only six input channels are used. This improves the quality of the sampling due to better isolation between the channels.

AIN12 is not under the control of INSEL[3:0]. It can be routed to ADC0/ADC1/ADC2 only by manual muxing. See Table 11 for details.

INSEL[3:0]	Description	
	Analog Input Pins	Video Format
1000	Y3 = AIN3 C3 = AIN6	YC
1001	Y1 = AIN1 PB1 = AIN4 PR1 = AIN5	YPrPb
1010	Y2 = AIN2 PB2 = AIN3 PR2 = AIN6	YPrPb
1011	CVBS7 = AIN7 B = AIN4 R = AIN5 G = AIN6	SCART (CVBS and R, G, B)
1100	CVBS8 = AIN8 B = AIN4 R = AIN5 G = AIN6	SCART (CVBS and R, G, B)
1101	CVBS9 = AIN9 B = AIN4 R = AIN5 G = AIN6	SCART (CVBS and R, G, B)
1110	CVBS10 = AIN10 B = AIN4 or AIN7 <sup>1</sup> R = AIN5 or AIN8 <sup>1</sup> G = AIN6 or AIN9 <sup>1</sup>	SCART (CVBS and R, G, B)
1111	CVBS11 = AIN11 B = AIN4 or AIN7 <sup>1</sup> R = AIN5 or AIN8 <sup>1</sup> G = AIN6 or AIN9 <sup>1</sup>	SCART (CVBS and R, G, B)

<sup>1</sup> Selectable via RGB\_IP\_SEL.

# ADV7184

## RGB\_IP\_SEL, Address 0xF1 [0]

For SCART input, R, G and B signals can be input on either AIN4, AIN5, and AIN6 or on AIN7, AIN8, and AIN9.

0 (default)—B is input on AIN4, R is input on AIN 5, and G is input on AIN6.

1—B is input on AIN7, R is input on AIN 8, and G is input on AIN9.

## MANUAL INPUT MUXING

By accessing a set of manual override muxing registers, the analog input muxes of the ADV7184 can be controlled directly. This is referred to as manual input muxing. Manual input muxing overrides other input muxing control bits, for example, INSEL.

Manual muxing is activated by setting the ADC\_SW\_MAN\_EN bit. It affects only the analog switches in front of the ADCs. This means if the settings of INSEL and the manual input muxing

registers (ADC0/ADC1/ADC2/ADC3\_SW) contradict each other, the ADC0/ADC1/ADC2 /ADC3\_SW settings apply and INSEL is ignored.

Manual input muxing controls only the analog input muxes. INSEL[3:0] still has to be set so the follow-on blocks process the video data in the correct format. This means INSEL must still be used to tell the ADV7184 whether the input signal is of component, YC, or CVBS format.

Restrictions in the channel routing are imposed by the analog signal routing inside the IC; every input pin cannot be routed to each ADC. Refer to Figure 6 for an overview on the routing capabilities inside the chip. The four mux sections can be controlled by the reserved control signal buses ADC0/ADC1/ADC2/ADC3\_SW[3:0]. Table 11 explains the control words used.

**Table 10. Input Channel Assignments**

Input Channel	Pin No.	ADI-Recommended Input Muxing Control INSEL[3:0]			
AIN7	41	CVBS7			SCART1-B
AIN1	42	CVBS1	YC1-Y	YPrPb1-Y	SCART2-CVBS
AIN8	43	CVBS8			SCART1-R
AIN2	44	CVBS2	YC2-Y	YPrPb2-Y	
AIN9	45	CVBS9			SCART1-G
AIN3	46	CVBS3	YC3-Y	YPrPb2-Pb	
AIN10	57	CVBS10			
AIN4	58	CVBS4	YC1-C	YPrPb1-Pb	SCART2-B
AIN11	59	CVBS11			SCART1-CVBS
AIN5	60	CVBS5	YC2-C	YPrPb1-Pr	SCART2-R
AIN12	61	Not Available			
AIN6	62	CVBS6	YC3-C	YPrPb2-Pr	SCART2-G

**Table 11. Manual Mux Settings for All ADCs (ADC\_SW\_MAN\_EN = 1)**

ADC0_sw[3:0]	ADC0 Connected To	ADC1_sw[3:0]	ADC1 Connected To	ADC2_sw[3:0]	ADC2 Connected To	ADC3_sw[3:0]	ADC3 Connected To
0000	No Connection	0000	No Connection	0000	No Connection	0000	No Connection
0001	AIN1	0001	No Connection	0001	No Connection	0001	No Connection
0010	AIN2	0010	No Connection	0010	AIN2	0010	No Connection
0011	AIN3	0011	AIN3	0011	No Connection	0011	No Connection
0100	AIN4	0100	AIN4	0100	No Connection	0100	AIN4
0101	AIN5	0101	AIN5	0101	AIN5	0101	No Connection
0110	AIN6	0110	AIN6	0110	AIN6	0110	No Connection
0111	No Connection	0111	No Connection	0111	No Connection	0111	No Connection
1000	No Connection	1000	No Connection	1000	No Connection	1000	No Connection
1001	AIN7	1001	No Connection	1001	No Connection	1001	AIN7
1010	AIN8	1010	No Connection	1010	AIN8	1010	No Connection
1011	AIN9	1011	AIN9	1011	No Connection	1011	No Connection
1100	AIN10	1100	AIN10	1100	No Connection	1100	No Connection
1101	AIN11	1101	AIN11	1101	AIN11	1101	No Connection
1110	AIN12	1110	AIN12	1110	AIN12	1110	No Connection
1111	No Connection	1111	No Connection	1111	No Connection	1111	No Connection

ADC\_SW\_MAN\_EN, Manual Input Muxing Enable, Address 0xC4 [7]

ADC0\_sw[3:0], ADC0 Mux Configuration, Address 0xC3 [3:0]

ADC1\_sw[3:0], ADC1 Mux Configuration, Address 0xC3 [7:4]

ADC2\_sw[3:0], ADC2 Mux Configuration, Address 0xC4 [3:0]

ADC3\_sw[3:0], ADC3 Mux Configuration, Address 0xF3 [7:4]

See Table 11.

### XTAL CLOCK INPUT PIN FUNCTIONALITY

XTAL\_TTL\_SEL, Address 0x13 [2]

The XTAL pad is normally part of the crystal oscillator circuit, powered from a 1.8 V supply. For optimal clock generation, the slice level of the input buffer of this circuit is at approximately half the supply voltage. This makes it incompatible with TTL level signals.

0 (default)—A crystal is used to generate the ADV7184's clock.

1—An external TTL level clock is supplied. A different input buffer can be selected, which slices at TTL-compatible levels. This inhibits operation of the crystal oscillator and, therefore, can only be used when a clock signal is applied.

### 28.63636 MHZ CRYSTAL OPERATION

EN28XTAL, Address 0x1D [6]

The ADV7184 can operate on two different base crystal frequencies. Selecting one over the other can be desirable in systems in which board crosstalk between different components leads to undesirable interference between video signals. It is recommended by ADI to use an XTAL of frequency 28.63636 MHz to clock the ADV7184. The programming examples at the end of this datasheet presume 28.63636 MHz crystal is used.

0 (default)—XTAL frequency is 27 MHz.

1—XTAL frequency is 28.63636 MHz.

### ANTI\_ALIASING FILTERS

The ADV7184 has optional antialiasing filters on each of the four input channels. The filters are designed for SD video with approximately 6 MHz bandwidth.

A plot of the filter response is shown in Figure 8. The filters can be individually enabled via I<sup>2</sup>C under the control of AA\_FILT\_EN[3:0].

AA\_FILT\_EN[0], Address 0xF3 [0]

0 (default)—The filter on channel 0 is disabled.

1—The filter on channel 0 is enabled.

AA\_FILT\_EN[1], Address 0xF3 [1]

0 (default)—The filter on channel 1 is disabled.

1—The filter on channel 1 is enabled.

AA\_FILT\_EN[2], Address 0xF3 [2]

0 (default)—The filter on channel 2 is disabled.

1—The filter on channel 2 is enabled.

AA\_FILT\_EN[3], Address 0xF3 [3]

0 (default)—The filter on channel 3 is disabled.

1—The filter on channel 3 is enabled.

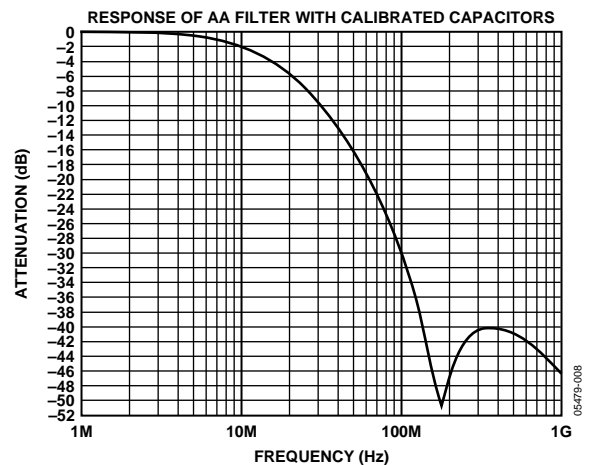

Figure 8. Frequency Response of Internal ADV7184 Antialiasing Filters

### SCART AND FAST BLANKING

The ADV7184 can support simultaneous processing of CVBS and RGB standard definition signals to enable SCART compatibility and overlay functionality.

This function is available when INSEL[3:0] is set appropriately (see Table 9). Timing extraction is always performed by the ADV7184 on the CVBS signal. However, a combination of the CVBS and RGB inputs can be mixed and output under control of I<sup>2</sup>C registers and the fast blank (FB) pin.

Four basic modes are supported:

#### Static Switch Mode

The FB pin is not used. The timing is extracted from the CVBS signal, and either the CVBS content or RGB content can be output under the control of CVBS\_RGB\_SEL. This mode allows the selection of a full-screen picture from either source. Overlay is not possible in static switch mode.

#### Fixed Alpha Blending

The FB pin is not used. The timing is extracted from the CVBS signal, and an alpha blended combination of the video from the CVBS and RGB sources is output. This alpha blending is applied to the full screen. The alpha blend factor is selected with the I<sup>2</sup>C signal MAN\_ALPHA[6:0]. Overlay is not possible in fixed alpha blending mode.

# ADV7184

## Dynamic Switching (Fast Mux)

Source selection is under the control of the fast blank (FB) pin. This enables dynamic multiplexing between the CVBS and RGB sources. With default settings, when Logic 1 is applied to the FB pin the RGB source is selected; when Logic 0 is applied to the FB pin the CVBS source is selected. This mode is suitable for the overlay of subtitles, teletext, or other material. Typically, the CVBS source carries the main picture and the RGB source has the overlay data.

## Dynamic Switching with Edge-Enhancement

This provides the same functionality as the dynamic switching mode, but with ADI proprietary edge-enhancement algorithms that improve the visual appearance of transitions for signals from a wide variety of sources.

## System Diagram

A block diagram of the ADV7184 fast blanking configuration is shown in Figure 9.

The CVBS signal is processed by the ADV7184 and converted to YPrPb. The RGB signals are processed by a color space converter (CSC) and samples are converted to YPrPb. Both sets of YPrPb signals are input to the sub-pixel blender, which can be configured to operate in any of the four modes outlined above.

The fast blank position resolver determines the time position of the FB to a very high accuracy (<1 ns); this position information is then used by the sub-pixel blender in dynamic switching modes. This enables the ADV7184 to implement high performance multiplexing between the CVBS and RGB sources, even when the RGB data source is completely asynchronous to the sampling crystal reference.

An antialiasing filter is required on all four data channels (R, G, B, and CVBS). The order of this filter is reduced as all of the signals are sampled at 54 MHz.

The switched or blended data is output from the ADV7184 in the standard output formats (see Table 99).

## FAST BLANK CONTROL

### FB\_MODE[1:0], Address 0xED [1:0]

FB\_MODE controls which of the fast blank modes is selected.

**Table 12. FB\_MODE[1:0] function**

FB_MODE[1:0]	Description
00 (default)	Static Switch Mode.
01	Fixed Alpha Blending.
10	Dynamic Switching (Fast Mux).
11	Dynamic Switching with Edge Enhancement.

## Static Mux Selection Control

### CVBS\_RGB\_SEL, Address 0xED [2]

CVBS\_RGB\_SEL controls whether the video from the CVBS or the RGB source is selected for output from the ADV7184.

0 (default)—Data from the CVBS source is selected for output.

1—Data from the RGB source is selected for output.

## Alpha Blend Coefficient

### MAN\_ALPHA\_VAL[6:0], Address 0xEE [6:0]

When FB\_MODE[1:0] = 01 and fixed alpha blending is selected, MAN\_ALPHA\_VAL[6:0] determines the proportion in which the video from the CVBS source and the RGB source are blended. Equation 1 shows how these bits affect the video output.

$$Video_{out} = Video_{CVBS} \times \left( 1 - \frac{MAN\_ALPHA\_VAL[6:0]}{64} \right) + Video_{RGB} \times \frac{MAN\_ALPHA\_VAL[6:0]}{64} \quad (1)$$

The maximum valid value for MAN\_ALPHA\_VAL[6:0] is 1000000 such that the alpha blender coefficients remain between 0 and 1. The default value for MAN\_ALPHA\_VAL[6:0] is 0000000.

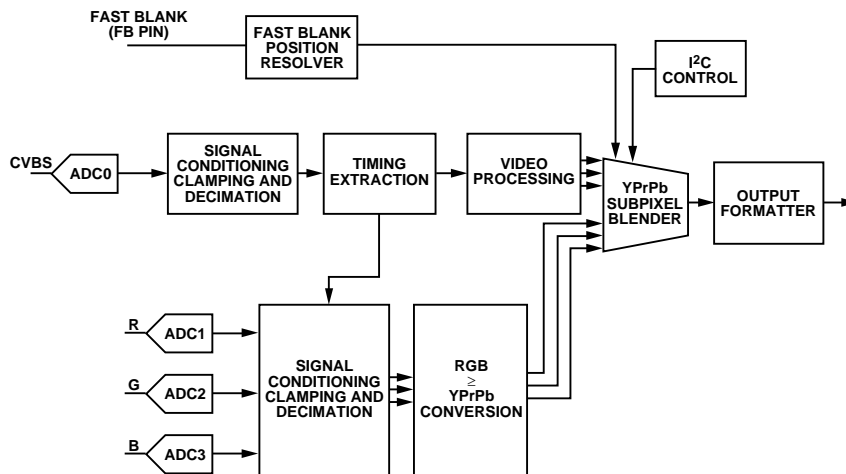

Figure 9. Fast Blank Block Diagram

**Fast Blank Edge Shaping**

**FB\_EDGE\_SHAPE[2:0], Address 0xEF [2:0]**

To improve the picture transition for high speed fast blank switching, an edge shape mode is available on the ADV7184. Depending on the format of the RGB inputs, it may be advantageous to apply this scheme to different degrees. The levels are selected via the FB\_EDGE\_SHAPE[2:0] bits. Users are advised to try each of the settings and select the setting that is most visually pleasing in their system.

**Table 13. FB\_EDGE\_SHAPE[2:0] Function**

FB_EDGE_SHAPE[2:0]	Description
000	No Edge Shaping.
001	Level 1 Edge Shaping.
010 (default)	Level 2 Edge Shaping.
011	Level 3 Edge Shaping.
100	Level 4 Edge Shaping.
101 to 111	Not Valid.

**Contrast Reduction**

For overlay applications, text can be more readable if the contrast of the video directly behind the text is reduced. To enable the definition of a window of reduced contrast behind inserted text, the signal applied to the FB pin can be interpreted as a tri-level signal, as shown in Figure 10.

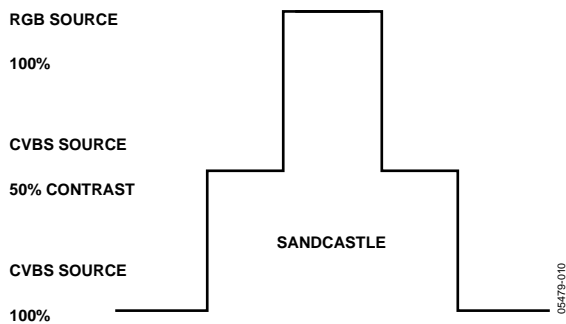

Figure 10. Fast Blank Signal Representation with Contrast Reduction Enabled

**Contrast Reduction Enable**

**CNTR\_ENABLE, Address 0xEF [3]**

This register enables the contrast reduction feature and changes the meaning of the signal applied to the FB pin.

- 0 (default)—The contrast reduction feature is disabled and the fast blank signal is interpreted as a bi-level signal.
- 1—The contrast reduction feature is enabled and the fast blank signal is interpreted as a tri-level signal.

**Contrast Mode**

**CNTR\_MODE[1:0], Address 0xF1 [3:2]**

The contrast level in the selected contrast reduction box is selected using the CNTR\_MODE[1:0] bits.

**Table 14. CNTR\_MODE[1:0] Function**

CNTR_MODE[1:0],	Description
00 (default)	25%.
01	50%.
10	75%.
11	100%.

**Fast Blank and Contrast Reduction Programmable Thresholds**

**FB\_LEVEL[1:0], Address 0xF1 [5:4]**

Controls the reference level for the fast blank comparator.

**CNTR\_LEVEL[1:0], Address 0xF1 [7:6]**

Controls the reference level for the contrast reduction comparator.

The internal fast-blank and contrast-reduction signals are resolved from the tri-level FB signal using two comparators, as shown in Figure 11. To facilitate compliance with different input level standards, the reference level to these comparators is programmable under the control of FB\_LEVEL[1:0] and CNTR\_LEVEL[1:0]. The resulting thresholds are given in Table 15.

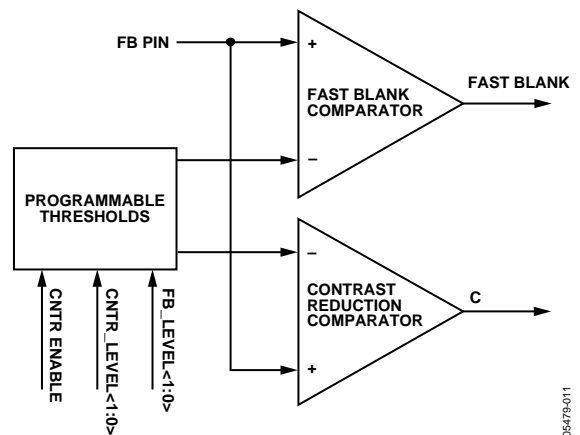

Figure 11. Fast Blank and Contrast Reduction Programmable Threshold

# ADV7184

**Table 15. Fast Blank and Contrast Reduction Programmable Threshold I<sup>2</sup>C Controls**

CNTR_ENABLE	FB_LEVEL[1:0]	CNTR_LEVEL[1:0]	Fast Blanking Threshold	Contrast Reduction Threshold
0	00 (default)	XX	1.4 V	n/a
0	01	XX	1.6 V	n/a
0	10	XX	1.8 V	n/a
0	11	XX	2.0 V	n/a
1	00 (default)	00	1.6 V	0.4 V
1	01	01	1.8 V	0.6 V
1	10	10	2.0 V	0.8 V
1	11	11	2.2 V	2.0 V

**Table 16. FB\_STATUS Functions**

FB_STATUS [3:0]	Bit Name	Description
0	FB_STATUS.0	<b>FB_rise.</b> A high value indicates there has been a rising edge on FB since the last I <sup>2</sup> C read. Value is cleared by current I <sup>2</sup> C read (self-clearing bit).
1	FB_STATUS.1	<b>FB_fall.</b> A high value indicates there has been a falling edge on FB since the last I <sup>2</sup> C read. Value is cleared by current I <sup>2</sup> C read (self-clearing bit).
2	FB_STATUS.2	<b>FB_stat.</b> Value of FB input pin at time of read.
3	FB_STATUS.3	<b>FB_high.</b> A high value indicates there has been a rising edge on FB since the last I <sup>2</sup> C read. Value is cleared by current I <sup>2</sup> C read (self-clearing bit).

## FB\_INV, Address 0xED [3] (write only)

The interpretation of the polarity of the signal applied to the FB pin can be changed using FB\_INV.

0 (default)—The fast blank pin is active high.

1—The fast blank pin is active low.

## READBACK OF FB PIN STATUS

### FB\_STATUS[3:0], Address 0xED [7:4]

FB\_STATUS[3:0] is a readback value that provides the system information on the status of the FB pins as shown in Table 16.

## FB Timing

### FB\_SP\_ADJUST[3:0], Address 0xEF [7:4]

The critical information extracted from the FB signal is the time at which it switches relative to the input video. Due to small timing inequalities either on the IC or on the PCB, it may be necessary to adjust the result by fractions of one clock cycle. This is controlled by FB\_SP\_ADJUST[3:0].

Each LSB of FB\_SP\_ADJUST[3:0] corresponds to 1/8 of an ADC clock cycle. Increasing the value is equivalent to adding delay to the FB signal. The reset value is chosen to give equalized channels when the ADV7184 internal antialiasing filters are enabled and there is no unintentional delay on the PCB.

The default value of FB\_SP\_ADJUST[3:0] is 0100.

## Alignment of FB Signal

### FB\_DELAY[3:0], Address 0xF0 [3:0]

In the event of misalignment between the FB input signal and the other input signals (CVBS, RGB) or unequalized delays in their processing, it is possible to alter the delay of the FB signal in 28.63636 MHz clock cycles. (For a finer granularity delay of the FB signal, refer to FB\_SP\_ADJUST[3:0], Address 0xEF [7:4] above.)

The default value of FB\_DELAY[3:0] is 0100.

## Color Space Converter Manual Adjust

### FB\_CSC\_MAN, Address 0xEE [7]

As shown in Figure 9, the data from the CVBS source and the RGB source are both converted to YPbPr before being combined. In the case of the RGB source, the color space converter (CSC) must be used to perform this conversion. When SCART support is enabled, the parameters for the CSC are automatically configured correctly for this operation.

If the user wishes to use a different conversion matrix, this autoconfiguration can be disabled and the CSC can be programmed manually. For details on this manual configuration, please contact ADI.

0 (default)—The CSC is configured automatically for the RGB to YPrPb conversion.

1—The CSC can be configured manually (not recommended).

## GLOBAL CONTROL REGISTERS

Register control bits listed in this section affect the whole chip.

### POWER-SAVE MODES

#### Power-Down

##### PDBP, Address 0x0F [2]

The digital core of the ADV7184 can be shut down by using a pin ( $\overline{\text{PWRDN}}$ ) and the PWRDN bit. The PDBP register controls which of the two has the higher priority. The default is to give the pin ( $\overline{\text{PWRDN}}$ ) priority. This allows the user to have the ADV7184 powered down by default.

0 (default)—The digital core power is controlled by the  $\overline{\text{PWRDN}}$  pin (the bit is disregarded).

1—The bit has priority (the pin is disregarded).

##### PWRDN, Address 0x0F [5]

Setting the PWRDN bit switches the ADV7184 into a chip-wide power-down mode. The power-down stops the clock from entering the digital section of the chip, thereby freezing its operation. No I<sup>2</sup>C bits are lost during power-down. The PWRDN bit also affects the analog blocks and switches them into low current modes. The I<sup>2</sup>C interface itself is unaffected, and remains operational in power-down mode.

The ADV7184 leaves the power-down state if the PWRDN bit is set to 0 (via I<sup>2</sup>C), or if the overall part is reset using the  $\overline{\text{RESET}}$  pin. Note that PDBP must be set to 1 for the PWRDN bit to power down the ADV7184.

0 (default)—The chip is operational.

1—The ADV7184 is in chip-wide power-down.

#### ADC Power-Down Control

The ADV7184 contains four 10-bit ADCs (ADC 0, ADC 1, ADC 2, and ADC3). If required, it is possible to power down each ADC individually.

- In CVBS mode, ADC 1 and ADC 2 should be powered down to save on power consumption.
- In S-Video mode, ADC 2 should be powered down to save on power consumption.

##### PWRDN\_ADC\_0, Address 0x3A [3]

0 (default)—The ADC is in normal operation.

1—ADC0 is powered down.

##### PWRDN\_ADC\_1, Address 0x3A [2]

0 (default)—The ADC is in normal operation.

1—ADC1 is powered down.

##### PWRDN\_ADC\_2, Address 0x3A [1]

0 (default)—The ADC is in normal operation.

1—ADC2 is powered down.

##### PWRDN\_ADC\_3, Address 0x3A [0]

0 (default)—The ADC is in normal operation.

1—ADC3 is powered down.

##### FB\_PWRDN, Address 0x0F [1]

To achieve very low power-down current, it is necessary to prevent activity on toggling input pins from reaching circuitry that could consume current. FB\_PWRDN gates signals from the FB input pin.

0 (default)—The FB input is in normal operation.

1—The FB input is in power-save mode.

## RESET CONTROL

### RES Chip Reset, Address 0x0F [7]

Setting this bit, equivalent to controlling the  $\overline{\text{RESET}}$  pin on the ADV7184, issues a full chip reset. All I<sup>2</sup>C registers are reset to their default values, making these bits self-clearing. (Some register bits do not have a reset value specified. They keep their last written value. Those bits are marked as having a reset value of x in the register tables.) After the reset sequence, the part immediately starts to acquire the incoming video signal.

Executing a software reset takes approximately 2 ms. However, it is recommended to wait 5 ms before performing any more I<sup>2</sup>C writes.

The I<sup>2</sup>C master controller receives a no acknowledge condition on the ninth clock cycle when chip reset is implemented. See the MPU Port Description section for a full description.

0 (default)—Operation is normal.

1—The reset sequence starts.

## GLOBAL PIN CONTROL

### Three-State Output Drivers

#### TOD, Address 0x03 [6]

This bit allows the user to three-state the output drivers of the ADV7184. Upon setting the TOD bit, the P15 to P0, HS, VS, FIELD, and SFL pins are three-stated. The ADV7184 also supports three-stating via a dedicated pin,  $\overline{\text{OE}}$ . The output drivers are three-stated if the TOD bit or the  $\overline{\text{OE}}$  pin is set high.

The timing pins (HS/VIS/FIELD) can be forced active via the TIM\_OE bit. For more information on three-state control, refer to the Three-State LLC Driver and the Timing Signals Output Enable sections. Individual drive strength controls are provided via the DR\_STR\_XX bits.

0 (default)—The output drivers are enabled.

1—The output drivers are three-stated.

# ADV7184

## Three-State LLC Driver

TRI\_LLC, Address 0x1D [7]

This bit allows the output drivers for the LLC1 and LLC2 pins of the ADV7184 to be three-stated. For more information on three-state control, refer to the Three-State Output Drivers and the Timing Signals Output Enable sections. Individual drive strength controls are provided via the DR\_STR\_XX bits.

0 (default)—The LLC pin drivers work according to the DR\_STR\_C[1:0] setting (pin enabled).

1—The LLC pin drivers are three-stated.

## Timing Signals Output Enable

TIM\_OE, Address 0x04 [3]

The TIM\_OE bit should be regarded as an addition to the TOD bit. Setting it high forces the output drivers for HS, VS, and FIELD into the active (that is, driving) state even if the TOD bit is set. If set to low, the HS, VS, and FIELD pins are three-stated, dependent on the TOD bit. This functionality is useful if the decoder is to be used as a timing generator only. This may be the case if only the timing signals are to be extracted from an incoming signal, or if the part is in free-run mode where, for example, a separate chip can output a company logo. For more information on three-state control, refer to the Three-State Output Drivers and the Three-State LLC Driver sections. Individual drive strength controls are provided via the DR\_STR\_XX bits.

0 (default)—HS, VS, and FIELD are three-stated according to the TOD bit.

1—HS, VS, and FIELD are forced active all the time.

## Drive Strength Selection (Data)

DR\_STR[1:0], Address 0xF4 [5:4]

For EMC and crosstalk reasons, it may be desirable to strengthen or weaken the drive strength of the output drivers. The DR\_STR[1:0] bits affect the P[15:0] output drivers.

For more information on three-state control, refer to the Drive Strength Selection (Clock) and the

Drive Strength Selection (Sync) sections.

**Table 17. DR\_STR Function**

DR_STR[1:0]	Description
01 (default)	Medium low drive strength (2×).
10	Medium high drive strength (3×).
11	High drive strength (4×).

## Drive Strength Selection (Clock)

DR\_STR\_C[1:0] Address 0xF4 [3:2]

The DR\_STR\_C[1:0] bits can be used to select the strength of the clock signal output driver (LLC pin). For more information, refer to the

Drive Strength Selection (Sync) and the Drive Strength Selection (Data) sections.

**Table 18. DR\_STR\_C Function**

DR_STR_C[1:0]	Description
01 (default)	Medium low drive strength (2×).
10	Medium high drive strength (3×).
11	High drive strength (4×).

## Drive Strength Selection (Sync)

DR\_STR\_S[1:0], Address 0xF4 [1:0]

The DR\_STR\_S[1:0] bits allow the user to select the strength of the synchronization signals with which HS, VS, and F are driven. For more information, refer to the Drive Strength Selection (Clock) and the Drive Strength Selection (Data) sections.

**Table 19. DR\_STR\_S Function**

DR_STR_S[1:0]	Description
01 (default)	Medium low drive strength (2×).
10	Medium high drive strength (3×).
11	High drive strength (4×).

## Enable Subcarrier Frequency Lock Pin

EN\_SFL\_PIN, Address 0x04 [1]

The EN\_SFL\_PIN bit enables the output of subcarrier lock information (also known as GenLock) from the ADV7184 to an encoder in a decoder-encoder back-to-back arrangement.

0 (default)—The subcarrier frequency lock output is disabled.

1—The subcarrier frequency lock information is presented on the SFL pin.

## Polarity LLC Pin

PCLK, Address 0x37 [0]

The polarity of the clock that leaves the ADV7184 via the LLC1 and LLC2 pins can be inverted using the PCLK bit. Changing the polarity of the LLC clock output may be necessary to meet the setup-and-hold time expectations of follow-on chips. This bit also inverts the polarity of the LLC2 clock.

0—The LLC output polarity is inverted.

1 (default)—The LLC output polarity is normal (as per the timing diagrams).

## GLOBAL STATUS REGISTERS

Three registers provide summary information about the video decoder. The STATUS\_1, STATUS\_2, and STATUS\_3 registers contain status bits that report operational information to the user.

### STATUS\_1[7:0], Address 0x10 [7:0]

This read-only register provides information about the internal status of the ADV7184. See CIL[2:0] Count Into Lock, Address 0x51 [2:0] and COL[2:0] Count Out of Lock, Address 0x51 [5:3] for information on the timing.

Depending on the setting of the FSCLE bit, the STATUS\_1[0] and STATUS\_1[1] bits are based solely on horizontal timing information or on the horizontal timing and lock status of the color subcarrier. See the FSCLE Fsc Lock Enable, Address 0x51 [7] section.

### STATUS\_2[7:0], Address 0x12 [7:0]

See Table 22.

**Table 21. STATUS\_1 Function**

STATUS 1 [7:0]	Bit Name	Description
0	IN_LOCK	In lock (right now).
1	LOST_LOCK	Lost lock (since last read of this register).
2	FSC_LOCK	Fsc locked (right now).
3	FOLLOW_PW	AGC follows peak white algorithm.
4	AD_RESULT.0	Result of autodetection.
5	AD_RESULT.1	Result of autodetection.
6	AD_RESULT.2	Result of autodetection.
7	COL_KILL	Color kill active.

**Table 22. STATUS\_2 Function**

STATUS 2 [7:0]	Bit Name	Description
0	MVCS DET	Detected Macrovision color striping.
1	MVCS T3	Macrovision color striping protection. Conforms to Type 3 if high, and to Type 2 if low.
2	MV_PS DET	Detected Macrovision pseudo Sync pulses.
3	MV_AGC DET	Detected Macrovision AGC pulses.
4	LL_NSTD	Line length is nonstandard.
5	FSC_NSTD	Fsc frequency is nonstandard.
6	Reserved	
7	Reserved	

**Table 23. STATUS\_3 Function**

STATUS 3 [7:0]	Bit Name	Description
0	INST_HLOCK	Horizontal lock indicator (instantaneous).
1	GEMD	Gemstar detect.
2	SD_OP_50HZ	Flags whether 50 Hz or 60 Hz is present at output.
3	CVBS	Indicates if a CVBS signal is detected in 'YC/CVBS autodetection' configuration
4	FREE_RUN_ACT	Indicates if the ADV7184 is in free run mode. Outputs a blue screen by default. See the DEF_VAL_AUTO_EN Default Value Automatic Enable, Address 0x0C [1] bit for details about disabling this function.
5	STD_FLD_LEN	Field length is correct for currently selected video standard.
6	INTERLACED	Interlaced video detected (field sequence found).
7	PAL_SW_LOCK	Reliable sequence of swinging bursts detected.

### STATUS\_3[7:0], Address 0x13 [7:0]

See Table 23.

### AD\_RESULT[2:0] Autodetection Result, Address 0x10 [6:4]

These bits report back on the findings from the autodetection block. For more information on enabling the autodetection block, see the General Setup section. For information on configuring it, see the Autodetection of SD Modes section.

**Table 20. AD\_RESULT Function**

AD_RESULT[2:0]	Description
000	NTSM-MJ.
001	NTSC-443.
010	PAL-M.
011	PAL-60.
100	PAL-BGHID.
101	SECAM.
110	PAL-Combination N.
111	SECAM 525.

## STANDARD DEFINITION PROCESSOR (SDP)

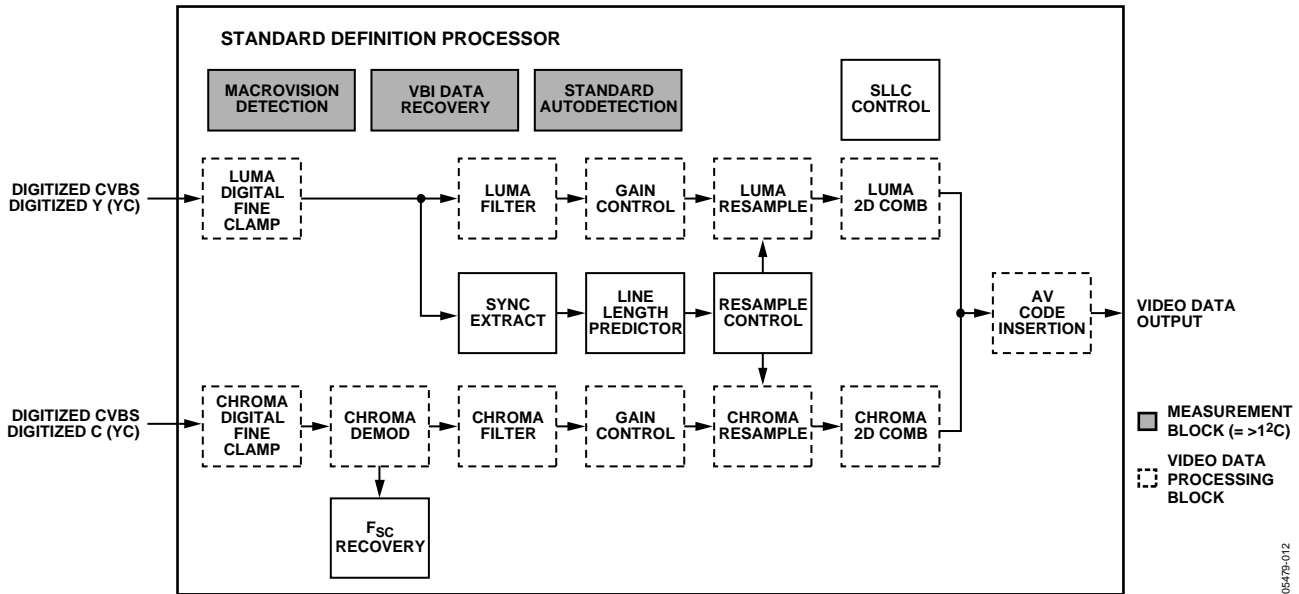

Figure 12. Block Diagram of the Standard Definition Processor

A block diagram of the ADV7184's standard definition processor (SDP) is shown in Figure 12.

The SDP block can handle standard definition video in CVBS, YC, and YPrPb formats. It can be divided into a luminance and a chrominance path. If the input video is of a composite type (CVBS), both processing paths are fed with the CVBS input.

### SD LUMA PATH

The input signal is processed by the following blocks:

- Digital Fine Clamp. This block uses a high precision algorithm to clamp the video signal.
- Luma Filter Block. This block contains a luma decimation filter (YAA) with a fixed response, and some shaping filters (YSH) that have selectable responses.
- Luma Gain Control. The automatic gain control (AGC) can operate on a variety of different modes, including gain based on the depth of the horizontal sync pulse, peak white mode, and fixed manual gain.
- Luma Resample. To correct for line-length errors as well as dynamic line-length changes, the data is digitally resampled.
- Luma 2D Comb. The two-dimensional comb filter provides YC separation.
- AV Code Insertion. At this point, the decoded luma (Y) signal is merged with the retrieved chroma values. AV codes (as per ITU-R. BT-656) can be inserted.

### SD CHROMA PATH

The input signal is processed by the following blocks:

- Digital Fine Clamp. This block uses a high precision algorithm to clamp the video signal.
- Chroma Demodulation. This block uses a color subcarrier (Fsc) recovery unit to regenerate the color subcarrier for any modulated chroma scheme. The demodulation block then performs an AM demodulation for PAL and NTSC, and an FM demodulation for SECAM.
- Chroma Filter Block. This block contains a chroma decimation filter (CAA) with a fixed response, and some shaping filters (CSH) that have selectable responses.
- Gain Control. Automatic gain control (AGC) can operate on several different modes, including gain based on the color subcarrier's amplitude, gain based on the depth of the horizontal sync pulse on the luma channel, or fixed manual gain.
- Chroma Resample. The chroma data is digitally resampled to keep it perfectly aligned with the luma data. The resampling is done to correct for static and dynamic line-length errors of the incoming video signal.
- Chroma 2D Comb. The two-dimensional, 5-line, superadaptive comb filter provides high quality YC separation in case the input signal is CVBS.
- AV Code Insertion. At this point, the demodulated chroma (Cr and Cb) signal is merged with the retrieved luma values. AV codes (as per ITU-R. BT-656) can be inserted.

## SYNC PROCESSING

The ADV7184 extracts syncs embedded in the video data stream. There is currently no support for external HS/VS inputs. The sync extraction has been optimized to support imperfect video sources, such as videocassette recorders with head switches. The actual algorithm used employs a coarse detection based on a threshold crossing, followed by a more detailed detection using an adaptive interpolation algorithm. The raw sync information is sent to a line-length measurement and prediction block. The output of this block is then used to drive the digital resampling section to ensure that the ADV7184 outputs 720 active pixels per line.

The sync processing on the ADV7184 also includes the following specialized postprocessing blocks that filter and condition the raw sync information retrieved from the digitized analog video.

- VSYNC Processor. This block provides extra filtering of the detected VSYNCS to give improved vertical lock.
- HSYNC Processor. The HSYNC processor is designed to filter incoming HSYNCS that have been corrupted by noise, providing much improved performance for video signals with stable time base but poor SNR.

## VBI DATA RECOVERY

The ADV7184 can retrieve the following information from the input video:

- Wide-screen signaling (WSS)
- Copy generation management system (CGMS)
- Closed caption (CC)
- Macrovision protection presence
- Gemstar-compatible data slicing
- Teletext
- VITC/VPS

The ADV7184 is also capable of automatically detecting the incoming video standard with respect to

- Color subcarrier frequency
- Field rate
- Line rate

The SDP can configure itself to support PAL-BGHID, PAL-M/N, PAL-combination N, NTSC-M, NTSC-J, SECAM 50 Hz/60 Hz, NTSC-4.43, and PAL-60.

## GENERAL SETUP

### Video Standard Selection

The VID\_SEL[3:0] register allows the user to force the digital core into a specific video standard. Under normal circumstances, this should not be necessary. The VID\_SEL[3:0] bits default to an autodetection mode that supports PAL, NTSC, SECAM, and variants thereof. The Autodetection of SD Modes section describes the autodetection system.

### Autodetection of SD Modes

To guide the autodetect system, individual enable bits are provided for each of the supported video standards. Setting the relevant bit to 0 inhibits the standard from being automatically detected. Instead, the system picks the closest of the remaining enabled standards. The results of the autodetection can be read back via the status registers. See the Global Status Registers section for more information.

VID\_SEL[3:0], Address 0x00 [7:4]

Table 24. VID\_SEL Function

VID_SEL[3:0]	Description
0000 (default)	Autodetect (PAL-BGHID) <-> NTSC-J (without pedestal), SECAM.
0001	Autodetect (PAL-BGHID) <-> NTSC-M (with pedestal), SECAM.
0010	Autodetect (PAL-N) (pedestal) <-> NTSC-J (without pedestal), SECAM.
0011	Autodetect (PAL-N) (pedestal) <-> NTSC-M (with pedestal), SECAM.
0100	NTSC-J (1).
0101	NTSC-M (1).
0110	PAL 60.
0111	NTSC-4.43 (1).
1000	PAL-BGHID.
1001	PAL-N (= PAL-BGHID (with pedestal)).
1010	PAL-M (without pedestal).
1011	PAL-M.
1100	PAL-combination N.
1101	PAL-combination N (with pedestal).
1110	SECAM.
1111	SECAM (with pedestal).

### AD\_SEC525\_EN Enable Autodetection of SECAM 525 Line Video, Address 0x07 [7]

0 (default)—Disables the autodetection of a 525-line system with a SECAM style, FM-modulated color component.

1—Enables autodetection.

### AD\_SECAM\_EN Enable Autodetection of SECAM, Address 0x07 [6]

0—Disables the autodetection of SECAM.

1 (default)—Enables autodetection.

# ADV7184

## AD\_N443\_EN Enable Autodetection of NTSC-443, Address 0x07 [5]

0—Disables the autodetection of NTSC style systems with a 4.43 MHz color subcarrier.

1 (default)—Enables autodetection.

## AD\_P60\_EN Enable Autodetection of PAL-60, Address 0x07 [4]

0—Disables the autodetection of PAL systems with a 60 Hz field rate.

1 (default)—Enables autodetection.

## AD\_PALN\_EN Enable Autodetection of PAL-N, Address 0x07 [3]

0—Disables the detection of the PAL N standard.

1 (default)—Enables autodetection.

## AD\_PALM\_EN Enable Autodetection of PAL-M, Address 0x07 [2]

0—Disables the autodetection of PAL M.

1 (default)—Enables autodetection.

## AD\_NTSC\_EN Enable Autodetection of NTSC, Address 0x07 [1]

0—Disables the autodetection of standard NTSC.

1 (default)—Enables autodetection.

## AD\_PAL\_EN Enable Autodetection of PAL, Address 0x07 [0]

0—Disables the autodetection of standard PAL.

1 (default)—Enables autodetection.

## Subcarrier Frequency Lock Inversion

The SFL\_INV bit controls the behavior of the PAL switch bit in the SFL (GenLock Telegram) data stream. It was implemented to solve some compatibility issues with video encoders. It solves two problems.

First, the PAL switch bit is only meaningful in PAL. Some encoders (including Analog Devices encoders) also look at the state of this bit in NTSC.

Second, there was a design change in Analog Devices encoders from ADV717x to ADV719x. The older versions used the SFL (GenLock Telegram) bit directly, while the later ones invert the bit prior to using it. The reason for this is that the inversion compensated for the 1-line delay of an SFL (GenLock Telegram) transmission.

As a result, ADV717x encoders need the PAL switch bit in the SFL (GenLock Telegram) to be 1 for NTSC to work. Also, the ADV7190/ADV7191/ADV7194 encoders need the PAL switch bit in the SFL to be 0 to work in NTSC. If the state of the PAL switch bit is wrong, a 180° phase shift occurs.

In a decoder/encoder back-to-back system in which SFL is used, this bit must be set up properly for the specific encoder used.

## SFL\_INV Address 0x41 [6]

0 (default)—Makes the part SFL-compatible with ADV7190/ADV7191/ADV7194 and ADV73xx encoders.

1—Makes the part SFL-compatible with ADV717x encoders.

## Lock-Related Controls

Lock information is presented to the user through Bits [1:0] of the Status 1 register. See the STATUS\_1 [7:0], Address 0x10 [7:0] section. Figure 13 outlines the signal flow and the controls available to influence the way the lock status information is generated.

## SRLS Select Raw Lock Signal, Address 0x51 [6]

Using the SRLS bit, the user can choose between two sources for determining the lock status (per Bits [1:0] in the Status 1 register).

The time\_win signal is based on a line-to-line evaluation of the horizontal synchronization pulse of the incoming video. It reacts quite quickly.

The free\_run signal evaluates the properties of the incoming video over several fields, and takes vertical synchronization information into account.

0 (default)—Selects the free\_run signal.

1—Selects the time\_win signal.

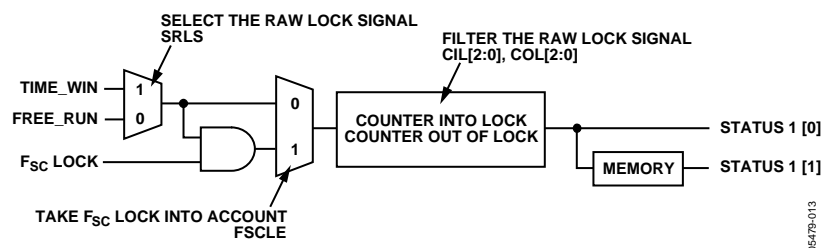

Figure 13. Lock-Related Signal Path

**FSCLE Fsc Lock Enable, Address 0x51 [7]**

The FSCLE bit allows the user to choose whether the status of the color subcarrier loop is taken into account when the overall lock status is determined and presented via Bits [1:0] in STATUS\_1. This bit must be set to 0 when operating in YPrPb component mode to generate a reliable HLOCK status bit.

0 (default)—Makes the overall lock status dependent on the horizontal sync lock only.

1—Makes the overall lock status dependent on horizontal sync lock and Fsc lock.

**VS\_Coast[1:0], Address 0xF9 [3:2]**

These bits are used to set VS free-run (coast) frequency.

**Table 25. VS\_COAST[1:0] function**

VS_COAST [1:0]	Description
00 (default)	Auto coast mode—follows VS frequency from last video input
01	Forces 50 Hz coast mode
10	Forces 60 Hz coast mode
11	Reserved

**CIL[2:0] Count Into Lock, Address 0x51 [2:0]**

CIL[2:0] determines the number of consecutive lines for which the into-lock condition must be true before the system switches into the locked state, and reports this via STATUS\_1[1:0]. It counts the value in lines of video.

**Table 26. CIL Function**

CIL[2:0]	Description
000	1
001	2
010	5
011	10
100 (default)	100
101	500
110	1000
111	100000

**COL[2:0] Count Out of Lock, Address 0x51 [5:3]**

COL[2:0] determines the number of consecutive lines for which the out of lock condition must be true before the system switches into unlocked state, and reports this via STATUS\_0[1:0]. It counts the value in lines of video.

**Table 27. COL Function**

COL[2:0]	Description
000	1
001	2
010	5
011	10
100 (default)	100
101	500
110	1000
111	100000

**ST\_NOISE\_VLD, HS Tip Noise Measurement Valid, Address 0xDE [3] (read only)**

0—The ST\_NOISE[10:0] measurement is not valid

1 (default)—The ST\_NOISE[10:0] measurement is valid.

**ST\_NOISE[10:0] HS Tip Noise Measurement, Address 0xDE [2:0], 0xDF [7:0]**

The ST\_NOISE[10:0] measures, over four fields, a readback value of the average of the noise in the HSYNC tip. ST\_NOISE\_VLD must be 1 for this measurement to be valid.

1 bit of ST\_NOISE[10:0] = 1 ADC code.

1 bit of ST\_NOISE[10:0] = 1.6 V/4096 = 390.625  $\mu$ V.

**COLOR CONTROLS**

These registers allow the user to control the picture appearance, including control of the active data in the event of video being lost. These controls are independent of any other controls. For instance, brightness control is independent of picture clamping, although both controls affect the signal's dc level.

**CON[7:0] Contrast Adjust, Address 0x08 [7:0]**

This register allows the user to adjust the contrast of the picture.

**Table 28. CON Function**

CON[7:0]	Description
0x80 (default)	Gain on luma channel = 1
0x00	Gain on luma channel = 0
0xFF	Gain on luma channel = 2

**SD\_SAT\_Cb[7:0] SD Saturation Cb Channel, Address 0xE3 [7:0]**

This register allows the user to control the gain of the Cb channel only. The user can adjust the saturation of the picture.

**Table 29. SD\_SAT\_Cb Function**

SD_SAT_Cb[7:0]	Description
0x80 (default)	Gain on Cb channel = 1
0x00	Gain on Cb channel = 0
0xFF	Gain on Cb channel = 2

**SD\_SAT\_Cr[7:0] SD Saturation Cr Channel, Address 0xE4 [7:0]**

This register allows the user to control the gain of the Cr channel only. The user can adjust the saturation of the picture.

**Table 30. SD\_SAT\_Cr Function**

SD_SAT_Cr[7:0]	Description
0x80 (default)	Gain on Cr channel = 1
0x00	Gain on Cr channel = 0
0xFF	Gain on Cr channel = 2

# ADV7184

## SD\_OFF\_Cb[7:0] SD Offset Cb Channel, Address 0xE1 [7:0]

This register allows the user to select an offset for data on the Cb channel only and adjust the hue of the picture. There is a functional overlap with the HUE [7:0] register.

**Table 31. SD\_OFF\_Cb Function**

SD_OFF_Cb[7:0]	Description
0x80 (default)	0 mV offset applied to the Cb channel
0x00	-568 mV offset applied to the Cb channel
0xFF	+568 mV offset applied to the Cb channel

## SD\_OFF\_Cr [7:0] SD Offset Cr Channel, Address 0xE2 [7:0]

This register allows the user to select an offset for data on the Cr channel only and adjust the hue of the picture. There is a functional overlap with the HUE [7:0] register.

**Table 32. SD\_OFF\_Cr Function**

SD_OFF_Cr[7:0]	Description
0x80 (default)	0 mV offset applied to the Cr channel
0x00	-568 mV offset applied to the Cr channel
0xFF	+568 mV offset applied to the Cr channel

## BRI[7:0] Brightness Adjust, Address 0x0A [7:0]

This register controls the brightness of the video signal. It allows the user to adjust the brightness of the picture.

**Table 33. BRI Function**

BRI[7:0]	Description
0x00 (default)	Offset of the luma channel = 0 mV
0x7F	Offset of the luma channel = +204 mV
0x80	Offset of the luma channel = -204 mV

## HUE[7:0] Hue Adjust, Address 0x0B [7:0]

This register contains the value for the color hue adjustment. It allows the user to adjust the hue of the picture.

HUE[7:0] has a range of  $\pm 90^\circ$ , with 0x00 equivalent to an adjustment of  $0^\circ$ . The resolution of HUE[7:0] is 1 bit =  $0.7^\circ$ .

The hue adjustment value is fed into the AM color demodulation block. Therefore, it only applies to video signals that contain chroma information in the form of an AM modulated carrier (CVBS or Y/C in PAL or NTSC). It does not affect SECAM and does not work on component video inputs (YPrPb).

**Table 34. HUE Function**

HUE[7:0]	Description
0x00 (default)	Phase of the chroma signal = $0^\circ$
0x7F	Phase of the chroma signal = $+90^\circ$
0x80	Phase of the chroma signal = $-90^\circ$

## DEF\_Y[5:0] Default Value Y, Address 0x0C [7:2]

If the ADV7184 loses lock on the incoming video signal or if there is no input signal, the DEF\_Y[5:0] bits allow the user to specify a default luma value to be output. The register is used under the following conditions:

- If DEF\_VAL\_AUTO\_EN bit is set to high and the ADV7184 loses lock to the input video signal. This is the intended mode of operation (automatic mode).
- The DEF\_VAL\_EN bit is set, regardless of the lock status of the video decoder. This is a forced mode that may be useful during configuration.

The DEF\_Y[5:0] values define the 6 MSBs of the output video. The remaining LSBs are padded with 0s. For example, in 8-bit mode, the output is  $Y[7:0] = \{DEF\_Y[5:0], 0, 0\}$ .

The value for Y is set by the DEF\_Y[5:0] bits. A value of 0x0D produces a blue color in conjunction with the DEF\_C[7:0] default setting.

Register 0x0C has a default value of 0x36.

## DEF\_C[7:0] Default Value C, Address 0x0D [7:0]

The DEF\_C[7:0] register complements the DEF\_Y[5:0] value. It defines the 4 MSBs of Cr and Cb values to be output if

- The DEF\_VAL\_AUTO\_EN bit is set to high and the ADV7184 can't lock to the input video (automatic mode).
- DEF\_VAL\_EN bit is set to high (forced output).

The data that is finally output from the ADV7184 for the chroma side is  $Cr[7:0] = \{DEF\_C[7:4], 0, 0, 0, 0\}$ ,  $Cb[7:0] = \{DEF\_C[3:0], 0, 0, 0, 0\}$ .

The values for Cr and Cb are set by DEF\_C[7:0] bits. A value of 0x7C produces a blue color in conjunction with the DEF\_Y[5:0] default setting.

## DEF\_VAL\_EN Default Value Enable, Address 0x0C [0]

This bit forces the use of the default values for Y, Cr, and Cb. Refer to the descriptions for DEF\_Y and DEF\_C for additional information. In this mode, the decoder also outputs a stable 27 MHz clock, HS, and VS.

0 (default)—Outputs a colored screen determined by user-programmable Y, Cr, and Cb values when the decoder free-runs. Free-run mode is turned on and off by the DEF\_VAL\_AUTO\_EN bit.

1—Forces a colored screen output determined by user-programmable Y, Cr, and Cb values. This overrides picture data even if the decoder is locked.

**DEF\_VAL\_AUTO\_EN Default Value Automatic Enable, Address 0x0C [1]**

This bit enables the automatic use of the default values for Y, Cr, and Cb when the ADV7184 cannot lock to the video signal.

0—Disables free-run mode. If the decoder is unlocked, it outputs noise.

1 (default)—Enables free-run mode. A colored screen set by the user-programmable Y, Cr, and Cb values is displayed when the decoder loses lock.

**CLAMP OPERATION**

The input video is ac-coupled into the ADV7184 through a 0.1  $\mu$ F capacitor. It is recommended that the range of the input video signal is 0.5 V to 1.6 V (typically 1 V p-p). If the signal exceeds this range, it cannot be processed correctly in the decoder. Since the input signal is ac-coupled into the decoder, its dc value needs to be restored. This process is referred to as clamping the video. This section explains the general process of clamping on the ADV7184, and shows the different ways in which a user can configure its behavior.

The ADV7184 uses a combination of current sources and a digital processing block for clamping, as shown in Figure 14. The analog processing channel shown is replicated three times inside the IC. While only one single channel (and only one ADC) is needed for a CVBS signal, two independent channels are needed for YC (S-VHS) type signals, and three independent channels are needed to allow component signals (YPrPb) to be processed.

The clamping can be divided into two sections:

- Clamping before the ADC (analog domain): current sources.
- Clamping after the ADC (digital domain): digital processing block.

The ADCs can digitize an input signal only if it resides within their 1.6 V input voltage range. An input signal with a dc level that is too large or too small is clipped at the top or bottom of the ADC range.

The primary task of the analog clamping circuits is to ensure that the video signal stays within the valid ADC input window so that the analog-to-digital conversion can take place. It is not necessary to clamp the input signal with a very high accuracy in the analog domain as long as the video signal fits the ADC range.

After digitization, the digital fine clamp block corrects for any remaining variations in dc level. Since the dc level of an input video signal refers directly to the brightness of the picture transmitted, it is important to perform a fine clamp with high accuracy; otherwise, brightness variations may occur. Furthermore, dynamic changes in the dc level almost certainly lead to visually objectionable artifacts, and must therefore be prohibited.

The clamping scheme must be able to acquire a newly connected video signal with a completely unknown dc level, and it must maintain the dc level during normal operation.

To quickly acquire an unknown video signal, the large current clamps may be activated. It is assumed that the amplitude of the video signal at this point is of a nominal value. Control of the coarse and fine current clamp parameters is automatically performed by the decoder.

Standard definition video signals may have excessive noise on them. In particular, CVBS signals transmitted by terrestrial broadcast and demodulated using a tuner usually show very large levels of noise (>100 mV). A voltage clamp would be unsuitable for this type of video signal. Instead, the ADV7184 uses a set of four current sources that can cause coarse (>0.5 mA) and fine (<0.1 mA) currents to flow into and away from the high impedance node that carries the video signal (see Figure 14).

The following sections describe the I<sup>2</sup>C signals that can be used to influence the behavior of the clamps on the ADV7184.

**CCLEN Current Clamp Enable, Address 0x14 [4]**

The current clamp enable bit allows the user to switch off the current sources in the analog front end altogether. This may be useful if the incoming analog video signal is clamped externally.

0—The current sources are switched off.

1 (default)—The current sources are enabled.

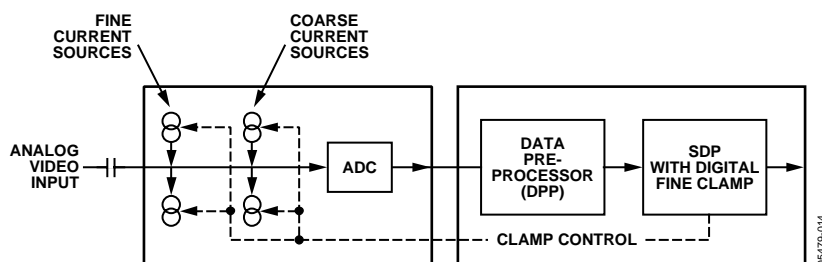

Figure 14. Clamping Overview

# ADV7184

## DCT[1:0] Digital Clamp Timing, Address 0x15 [6:5]

The clamp timing register determines the time constant of the digital fine clamp circuitry. It is important to realize that the digital fine clamp reacts very quickly since it is supposed to immediately correct any residual dc level error for the active line. The time constant of the digital fine clamp must be much quicker than the one from the analog blocks.

By default, the time constant of the digital fine clamp is adjusted dynamically to suit the currently connected input signal.

**Table 35. DCT Function**

DCT[1:0]	Description
00	Slow (TC = 1 sec).
01	Medium (TC = 0.5 sec).
10 (default)	Fast (TC = 0.1 sec).
11	Determined by the ADV7184, depending on the I/P video parameters.

## DCFE Digital Clamp Freeze Enable, Address 0x15 [4]

This register bit allows the user to freeze the digital clamp loop at any time. It is intended for users who would like to do their own clamping. Users should disable the current sources for analog clamping via the appropriate register bits, wait until the digital clamp loop settles, and then freeze it via the DCFE bit.

0 (default)—The digital clamp is operational.

1—The digital clamp loop is frozen.

## LUMA FILTER

Data from the digital fine clamp block is processed by three sets of filters. The data format at this point is CVBS for CVBS input or luma only for Y/C and YPrPb input formats.

- Luma antialias filter (YAA). The ADV7184 receives video at a rate of 27 MHz. For 4× oversampled video, the ADCs sample at 54 MHz, and the first decimation is performed inside the DPP filters. Therefore, the data rate into the SDP core is always 27 MHz. The ITU-R BT.601 recommends a sampling frequency of 13.5 MHz. The luma antialias filter decimates the oversampled video using a high quality, linear phase, low-pass filter that preserves the luma signal while at the same time attenuating out-of-band components. The luma antialias filter has a fixed response.
- Luma shaping filters (YSH). The shaping filter block is a programmable low-pass filter with a wide variety of responses. It can be used to selectively reduce the luma video signal bandwidth (needed prior to scaling, for example). For some video sources that contain high frequency noise, reducing the bandwidth of the luma signal improves visual picture quality. A follow-on video compression stage may work more efficiently if the video is low-pass filtered.

The ADV7184 has two responses for the shaping filter: one that is used for good quality CVBS, component, and S-VHS type sources, and a second for nonstandard CVBS signals.

The YSH filter responses also include a set of notches for PAL and NTSC. However, it is recommended to use the comb filters for YC separation.

- Digital resampling filter. This block is used to allow dynamic resampling of the video signal to alter parameters such as the time base of a line of video. Fundamentally, the resampler is a set of low-pass filters. The actual response is chosen by the system with no requirement for user intervention.

Figure 16 through Figure 19 show the overall response of all filters together. Unless otherwise noted, the filters are set into a typical wideband mode.

## Y-Shaping Filter

For input signals in CVBS format, the luma shaping filters play an essential role in removing the chroma component from a composite signal. YC separation must aim for best possible crosstalk reduction while still retaining as much bandwidth (especially on the luma component) as possible. High quality YC separation can be achieved by using the internal comb filters of the ADV7184. Comb filtering, however, relies on the frequency relationship of the luma component (multiples of the video line rate) and the color subcarrier (Fsc). For good quality CVBS signals, this relationship is known; the comb filter algorithms can be used to separate out luma and chroma with high accuracy.

For nonstandard video signals, the frequency relationship may be disturbed and the comb filters may not be able to remove all crosstalk artifacts in an optimum fashion without the assistance of the shaping filter block.

An automatic mode is provided. Here, the ADV7184 evaluates the quality of the incoming video signal and selects the filter responses in accordance with the signal quality and video standard. YFSM, WYSFMOVR, and WYSFM allow the user to manually override the automatic decisions in part or in full.

The luma shaping filter has three control registers

- YFSM[4:0] allows the user to manually select a shaping filter mode (applied to all video signals) or to enable an automatic selection (dependent on video quality and video standard).
- WYSFMOVR allows the user to manually override the WYSFM decision.
- WYSFM[4:0] allows the user to select a different shaping filter mode for good quality CVBS, component (YPrPb), and S-VHS (YC) input signals.

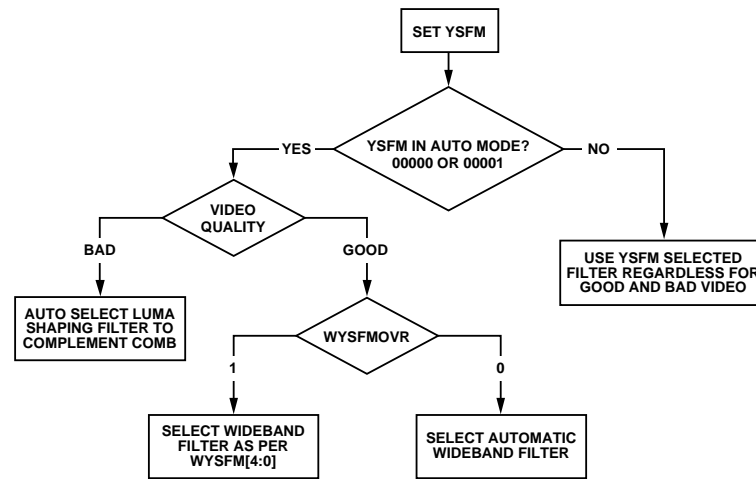

Figure 15. YSFM and WYSFM Control Flowchart

In automatic mode, the system preserves the maximum possible bandwidth for good CVBS sources (since they can successfully be combed) as well as for luma components of YPrPb and YC sources, since they need not be combed. For poor quality signals, the system selects from a set of proprietary shaping filter responses that complements comb filter operation in order to reduce visual artifacts. The decisions of the control logic are shown in Figure 15.

**YSFM[4:0] Y Shaping Filter Mode, Address 0x17 [4:0]**

The Y shaping filter mode bits allow the user to select from a wide range of low-pass and notch filters. When switched in automatic mode, the filter is selected based on other register selections, such as detected video standard, as well as properties extracted from the incoming video itself, such as quality and time base stability. The automatic selection always picks the widest possible bandwidth for the video input encountered.

If the YSFM settings specify a filter (that is, YSFM is set to values other than 00000 or 00001), the chosen filter is applied to all video, regardless of its quality.

In automatic selection mode, the notch filters are used only for bad quality video signals. For all other video signals, wideband filters are used; see Table 36.

**WYSFMOVR Wideband Y Shaping Filter Override, Address 0x18,[7]**

Setting the WYSFMOVR bit enables use of the WYSFM[4:0] settings for good quality video signals. For more information, refer to the general discussion of the luma shaping filters in the Y-Shaping Filter section and the flowchart shown in Figure 15.

0—The shaping filter for good quality video signals is selected automatically.

1 (default)—Enables manual override via WYSFM[4:0].

**Table 36. YSFM Function**

YSFM[4:0]	Description
00000	Automatic selection including a wide notch response (PAL/NTSC/SECAM)
00001 (default)	Automatic selection including a narrow notch response (PAL/NTSC/SECAM)
00010	SVHS 1
00011	SVHS 2
00100	SVHS 3
00101	SVHS 4
00110	SVHS 5
00111	SVHS 6
01000	SVHS 7
01001	SVHS 8
01010	SVHS 9
01011	SVHS 10
01100	SVHS 11
01101	SVHS 12
01110	SVHS 13
01111	SVHS 14
10000	SVHS 15
10001	SVHS 16
10010	SVHS 17
10011	SVHS 18 (CCIR 601)
10100	PAL NN 1
10101	PAL NN 2
10110	PAL NN 3
10111	PAL WN 1
11000	PAL WN 2
11001	NTSC NN 1
11010	NTSC NN 2
11011	NTSC NN 3
11100	NTSC WN 1
11101	NTSC WN 2
11110	NTSC WN 3
11111	Reserved

# ADV7184

## WYSFM[4:0] Wide Band Y Shaping Filter Mode, Address 0x18 [4:0]

The WYSFM[4:0] bits allow the user to manually select a shaping filter for good quality video signals, for example, CVBS with stable time base, luma component of YPrPb, and luma component of YC. The WYSFM bits are only active if the WYSFMOVR bit is set to 1. See the general discussion of the shaping filter settings in the Y-Shaping Filter section.

**Table 37. WYSFM Function**

WYSFM[4:0]	Description
00000	Do not use
00001	Do not use
00010	SVHS 1
00011	SVHS 2
00100	SVHS 3
00101	SVHS 4
00110	SVHS 5
00111	SVHS 6
01000	SVHS 7
01001	SVHS 8
01010	SVHS 9
01011	SVHS 10
01100	SVHS 11
01101	SVHS 12
01110	SVHS 13
01111	SVHS 14
10000	SVHS 15
10001	SVHS 16
10010	SVHS 17
10011 (default)	SVHS 18 (CCIR 601)
10100–11111	Do not use

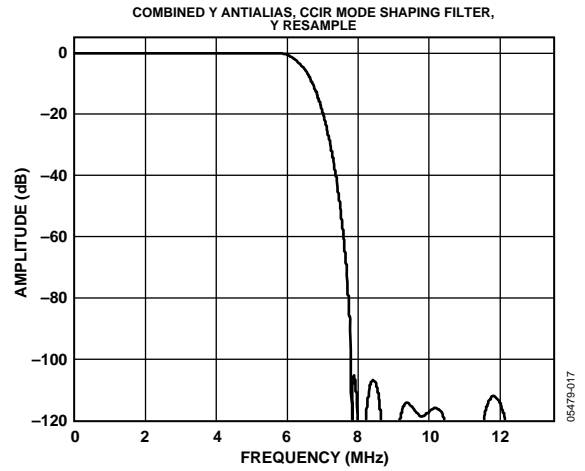

Figure 17. Y S-VHS 18 Extra Wideband Filter (CCIR 601-Compliant)

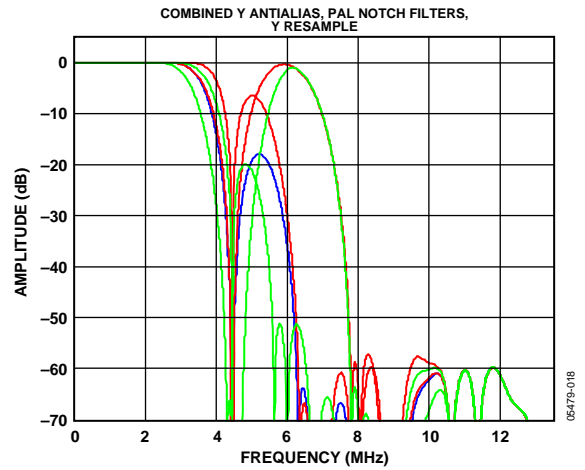

Figure 18. Y PAL Notch Filter Responses

The filter plots in Figure 16 show the S-VHS 1 (narrowest) to S-VHS 18 (widest) shaping filter settings. Figure 18 shows the PAL notch filter responses. The NTSC-compatible notches are shown in Figure 19.

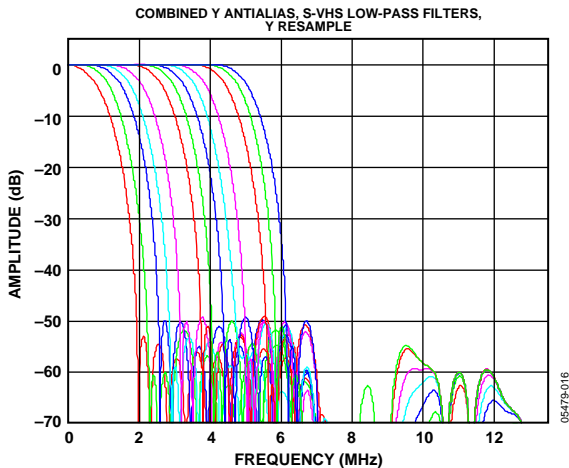

Figure 16. Y S-VHS Combined Responses

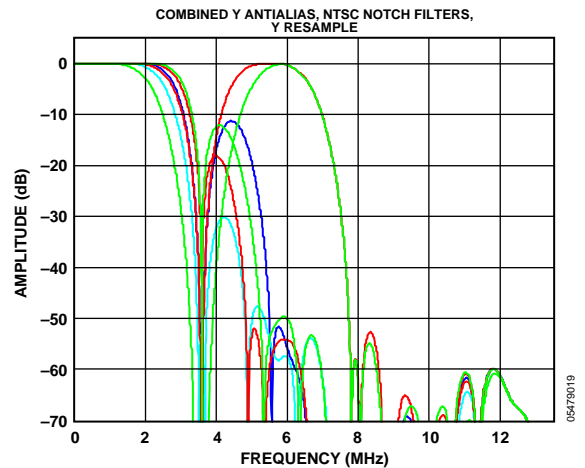

Figure 19. NTSC Notch Filter Responses

## CHROMA FILTER

Data from the digital fine clamp block is processed by three sets of filters. The data format at this point is CVBS for CVBS inputs, chroma only for Y/C, or Cr/Cb interleaved for YPrPb input formats.

- Chroma Antialias Filter (CAA). The ADV7184 over-samples the CVBS by a factor of 2 and the Chroma/CrCb by a factor of 4. A decimating filter (CAA) is used to preserve the active video band and to remove any out-of-band components. The CAA filter has a fixed response.
- Chroma Shaping Filters (CSH). The shaping filter block (CSH) can be programmed to perform a variety of low-pass responses. It can be used to selectively reduce the bandwidth of the chroma signal for scaling or compression.
- Digital Resampling Filter. This block is used to allow dynamic resampling of the video signal to alter parameters such as the time base of a line of video. Fundamentally, the resampler is a set of low-pass filters. The actual response is chosen by the system without user intervention.

The plots in Figure 20 show the overall response of all filters together, from SH1 (narrowest) to SH5 (widest) in addition to the wideband mode (in red).

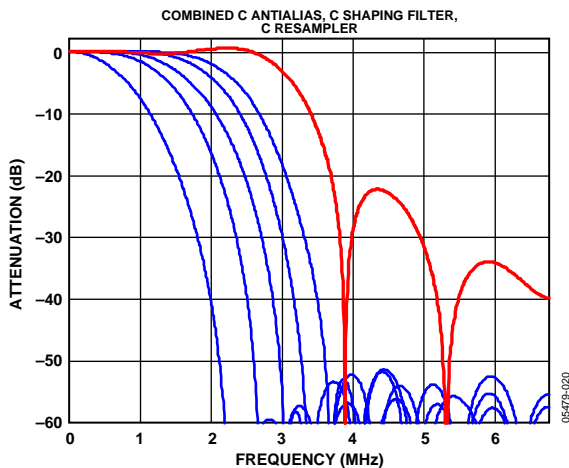

Figure 20. Chroma Shaping Filter Responses

### CSFM[2:0] C-Shaping Filter Mode, Address 0x17 [7]

The C-shaping filter mode bits allow the user to select from a range of low-pass filters for the chrominance signal.

Table 38. CSFM Function

CSFM[2:0]	Description
000 (default)	1.5 MHz bandwidth filter.
001	2.17 MHz bandwidth filter.
010	SH1.
011	SH2.
100	SH3.
101	SH4.
110	SH5.
111	Wideband mode.

## GAIN OPERATION

The gain control within the ADV7184 is done on a purely digital basis. The input ADCs support a 10-bit range, mapped into a 1.6 V analog voltage range. Gain correction takes place after the digitization in the form of a digital multiplier.

Advantages of this architecture over the commonly used PGA (programmable gain amplifier) before the ADCs include that the gain is now completely independent of supply, temperature, and process variations.

As shown in Figure 21, the ADV7184 can decode a video signal as long as it fits into the ADC window. The two components to this are the amplitude of the input signal and the dc level on which it resides. The dc level is set by the clamping circuitry (see the Clamp Operation section).

If the amplitude of the analog video signal is too high, clipping may occur, resulting in visual artifacts. The analog input range of the ADC, together with the clamp level, determines the maximum supported amplitude of the video signal.

The minimum supported amplitude of the input video is determined by the ADV7184's ability to retrieve horizontal and vertical timing and to lock to the color burst if present.

There are separate gain control units for luma and chroma data. Both can operate independently of each other. The chroma unit, however, can also take its gain value from the luma path.

The possible AGC modes are summarized in Table 39.

It is possible to freeze the automatic gain control loops. This causes the loops to stop updating and the AGC-determined gain at the time of the freeze to stay active until the loop is either unfrozen or the gain mode of operation is changed.

The currently active gain from any of the modes can be read back. Refer to the description of the dual function manual gain registers, LG[11:0] Luma Gain and CG[11:0] Chroma Gain, in the Luma Gain and Chroma Gain sections.

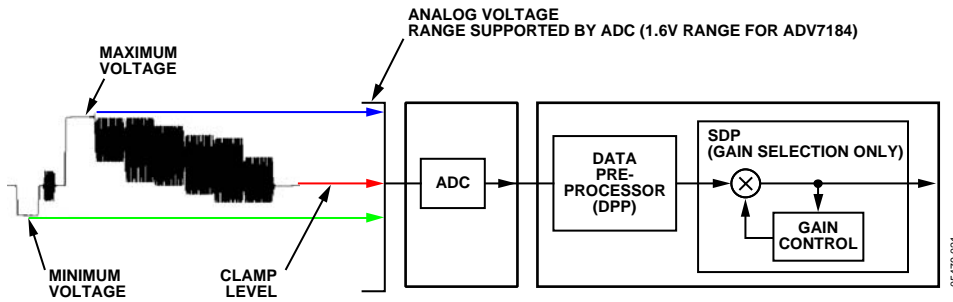

Figure 21. Gain Control Overview

Table 39. AGC Modes

Input Video Type	Luma Gain	Chroma Gain
Any	Manual gain luma.	Manual gain chroma.
CVBS	Dependent on horizontal sync depth.	Dependent on color burst amplitude. Taken from luma path.
	Peak white.	Dependent on color burst amplitude. Taken from luma path.
Y/C	Dependent on horizontal sync depth.	Dependent on color burst amplitude. Taken from luma path.
	Peak white.	Dependent on color burst amplitude. Taken from luma path.
YPrPb	Dependent on horizontal sync depth.	Taken from luma path.

**Luma Gain**

**LAGC[2:0] Luma Automatic Gain Control, Address 0x2C [6:4]**

The luma automatic gain control mode bits select the mode of operation for the gain control in the luma path. There are ADI internal parameters to customize the peak white gain control. Contact ADI for more information.

Table 40. LAGC Function

LAGC[2:0]	Description
000	Manual fixed gain (use LMG[11:0]).
001	AGC (blank level to sync tip). Peak white algorithm OFF.
010 (default)	AGC (blank level to sync tip). Peak white algorithm ON.
011	Reserved.
100	Reserved.
101	Reserved.
110	Reserved.
111	Freeze gain.

**LAGT[1:0] Luma Automatic Gain Timing, Address 0x2F [7:6]**

The luma automatic gain timing register allows the user to influence the tracking speed of the luminance automatic gain control. Note that this register only has an effect if the LAGC[2:0] register is set to 001, 010, 011, or 100 (automatic gain control modes).

If peak white AGC is enabled and active (see the section STATUS\_1[7:0], Address 0x10 [7:0]), the actual gain update speed is dictated by the peak white AGC loop and, as a result, the LAGT settings have no effect. As soon as the part leaves peak white AGC, LAGT becomes relevant again.

The update speed for the peak white algorithm can be customized by the use of internal parameters. Contact ADI for more information.

Table 41. LAGT Function

LAGT[1:0]	Description
00	Slow (TC = 2 sec).
01	Medium (TC = 1 sec).
10	Fast (TC = 0.2 sec).
11 (default)	Adaptive.

**LG[11:0] Luma Gain, Address 0x2F [3:0]; Address 0x30 [7:0]; LMG[11:0] Luma Manual Gain, Address 0x2F [3:0]; Address 0x30 [7:0]**

Luma gain [11:0] is a dual-function register. If written to, a desired manual luma gain can be programmed. This gain becomes active if the LAGC[2:0] mode is switched to manual fixed gain. Equation 2 and Equation 3 show how to calculate a desired gain for NTSC and PAL, respectively.

$$\begin{aligned}
 \text{NTSC Luma Gain} &= \\
 \frac{1024 < \text{LMG}[11:0] \leq 4095}{1128} &= 0.9078\dots 3.63 \quad (2)
 \end{aligned}$$

$$\begin{aligned}
 \text{PAL Luma Gain} &= \\
 \frac{1024 < \text{LMG}[11:0] \leq 4095}{1222} &= 0.838\dots 3.351 \quad (3)
 \end{aligned}$$

If read back, this register returns the current gain value. Depending on the setting in the LAGC[2:0] bits, this is one of the following values:

- Luma manual gain value (LAGC[2:0] set to luma manual gain mode).
- Luma automatic gain value (LAGC[2:0] set to any of the automatic modes).

**Table 42. LG/LMG Function**

LG[11:0]/LMG[11:0]	Read/Write	Description
LMG[11:0] = X	Write	Manual gain for luma path.
LG[11:0]	Read	Actually used gain.

For example, to program the ADV7184 into manual fixed gain mode with a desired gain of 0.95 for the NTSC standard:

1. Use Equation 2 to convert the gain:  
 $0.95 \times 1128 = 1071.6$
2. Truncate to integer value:  
 $1071.6 = 1071$
3. Convert to hexadecimal:  
 $1071d = 0x42F$
4. Split into two registers and program:  
Luma Gain Control 1 [3:0] = 0x4  
Luma Gain Control 2 [7:0] = 0x2F
5. Enable manual fixed gain mode:  
Set LAGC[2:0] to 000

**BETACAM Enable Betacam Levels, Address 0x01 [5]**

If YPrPb data is routed through the ADV7184, the automatic gain control modes can target different video input levels, as outlined in Table 45. Note that the BETACAM bit is valid only if the input mode is YPrPb (component). The BETACAM bit sets the target value for AGC operation. A review of the following sections is useful:

- INSEL[3:0] Input Selection, Address 0x00 [3:0] to find how component video (YPrPb) can be routed through the ADV7184.
- Video Standard Selection to select the various standards, for example, with and without pedestal.

**Table 45. Betacam Levels**

Name	Betacam (mV)	Betacam Variant (mV)	SMPTE (mV)	MII (mV)
Y Range	0 to 714 (incl. 7.5% pedestal)	0 to 714	0 to 700	0 to 700 (incl. 7.5% pedestal)
Pb and Pr Range	-467 to +467	-505 to +505	-350 to +350	-324 to +324
Sync Depth	286	286	300	300

The automatic gain control (AGC) algorithms adjust the levels based on the setting of the BETACAM bit (see Table 43).

**Table 43. BETACAM Function**

BETACAM	Description
0 (default)	Assuming YPrPb is selected as input format. Selecting PAL with pedestal selects MII. Selecting PAL without pedestal selects SMPTE. Selecting NTSC with pedestal selects MII. Selecting NTSC without pedestal selects SMPTE.
1	Assuming YPrPb is selected as input format. Selecting PAL with pedestal selects BETACAM. Selecting PAL without pedestal selects BETACAM variant. Selecting NTSC with pedestal selects BETACAM. Selecting NTSC without pedestal selects BETACAM variant.

**PW\_UPD Peak White Update, Address 0x2B [0]**

The peak white and average video algorithms determine the gain based on measurements taken from the active video. The PW\_UPD bit determines the rate of gain change. LAGC[2:0] must be set to the appropriate mode to enable the peak white or average video mode in the first place. For more information, refer to the LAGC[2:0] Luma Automatic Gain Control, Address 0x2C [6:4] section.

- 0—Updates the gain once per video line.
- 1 (default)—Updates the gain once per field.

**Chroma Gain**

**CAGC[1:0] Chroma Automatic Gain Control, Address 0x2C [1:0]**

These two bits select the basic mode of operation for automatic gain control in the chroma path.

**Table 44. CAGC Function**

CAGC[1:0]	Description
00	Manual fixed gain (use CMG[11:0]).
01	Use luma gain for chroma.
10 (default)	Automatic gain (based on color burst).
11	Freeze chroma gain.

# ADV7184

## CAGT[1:0] Chroma Automatic Gain Timing, Address 0x2D [7:6]

This register allows the user to influence the tracking speed of the chroma automatic gain control. It has an effect only if the CAGC[1:0] register is set to 10 (automatic gain).

**Table 46. CAGT Function**

CAGT[1:0]	Description
00	Slow (TC = 2 sec).
01	Medium (TC = 1 sec).
10	Fast (TC = 0.2 sec).
11 (default)	Adaptive.

## CG[11:0] Chroma Gain, Address 0x2D [3:0]; Address 0x2E [7:0] CMG[11:0] Chroma Manual Gain, Address 0x2D [3:0]; Address 0x2E [7:0]

CG[11:0] is a dual-function register. If written to, a desired manual chroma gain can be programmed. This gain becomes active if the CAGC[1:0] mode is switched to manual fixed gain. Refer to Equation 4 for calculating a desired gain. If read back the register returns the current gain value. Depending on the setting in the CAGC[1:0] bits, this is either:

- Chroma manual gain value (CAGC[1:0] set to chroma manual gain mode).
- Chroma automatic gain value (CAGC[1:0] set to any of the automatic modes).

**Table 47. CG/CMG Function**

CG[11:0]/CMG[11:0]	Read/Write	Description
CMG[11:0]	Write	Manual gain for chroma path.
CG[11:0]	Read	Currently active gain.

$$\text{Chroma\_Gain} = \frac{(0 < CG \leq 4095)}{1024} = 0...4 \quad (4)$$

For example, freezing the automatic gain loop and reading back the CG[11:0] register results in a value of 0x47A.

1. Convert the readback value to decimal:  
0x47A = 1146d
2. Apply Equation 4 to convert the readback value:  
1146/1024 = 1.12

## CKE Color Kill Enable, Address 0x2B [6]

This bit allows the optional color kill function to be switched on or off. For QAM-based video standards (PAL and NTSC) and FM-based systems (SECAM), the threshold for the color kill decision is selectable via the CKILLTHR[2:0] bits.

If color kill is enabled, and if the color carrier of the incoming video signal is less than the threshold for 128 consecutive video lines, color processing is switched off (black and white output). To switch the color processing back on, another 128 consecutive lines with a color burst greater than the threshold are required.

The color kill option only works for input signals with a modulated chroma part. For component input (YPrPb), there is no color kill.

0—Disables color kill.

1 (default)—Enables color kill.

## CKILLTHR[2:0] Color Kill Threshold, Address 0x3D [6:4]

The CKILLTHR[2:0] bits allow the user to select a threshold for the color kill function. The threshold applies only to QAM-based (NTSC and PAL) or FM-modulated (SECAM) video standards.

To enable the color kill function, the CKE bit must be set. For settings 000, 001, 010, and 011, chroma demodulation inside the ADV7184 may not work satisfactorily for poor input video signals.

**Table 48. CKILLTHR Function**

CKILLTHR[2:0]	Description	
	SECAM	NTSC, PAL
000	No color kill	Kill at < 0.5%
001	Kill at < 5%	Kill at < 1.5%
010	Kill at < 7%	Kill at < 2.5%
011	Kill at < 8%	Kill at < 4.0%
100 (default)	Kill at < 9.5%	Kill at < 8.5%
101	Kill at < 15%	Kill at < 16.0%
110	Kill at < 32%	Kill at < 32.0%
111	Reserved for ADI internal use only. Do not select.	

## CHROMA TRANSIENT IMPROVEMENT (CTI)

The signal bandwidth allocated for chroma is typically much smaller than that of luminance. In the past, this was a valid way to fit a color video signal into a given overall bandwidth because the human eye is less sensitive to chrominance than to luminance.

The uneven bandwidth, however, may lead to visual artifacts in sharp color transitions. At the border of two bars of color, both components (luma and chroma) change at the same time (see Figure 22). Due to the higher bandwidth, the signal transition of the luma component is usually much sharper than that of the chroma component. The color edge is not sharp but blurred, in the worst case over several pixels.

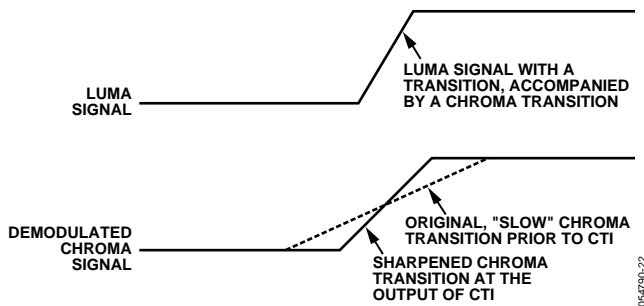

Figure 22. CTI Luma/Chroma Transition

The CTI block examines the input video data. It detects transitions of chroma, and can be programmed to steepen the chroma edges in an attempt to artificially restore lost color bandwidth. However, it operates only on edges above a certain threshold to ensure that noise is not emphasized. Care has also been taken to avoid edge ringing and undesirable saturation and hue distortion.

Chroma transient improvements are needed primarily for signals that experienced severe chroma bandwidth limitations. For those types of signals, it is strongly recommended to enable the CTI block via CTI\_EN.

**CTI\_EN Chroma Transient Improvement Enable, Address 0x4D [0]**

- 0—Disables the CTI block.
- 1 (default)—Enables the CTI block.

**CTI\_AB\_EN Chroma Transient Improvement Alpha Blend Enable, Address 0x4D [1]**

This bit enables an alpha-blend function, which mixes the transient improved chroma with the original signal. The sharpness of the alpha blending can be configured via the CTI\_AB[1:0] bits. For the alpha blender to be active, the CTI block must be enabled via the CTI\_EN bit.

- 0—Disables the CTI alpha blender.
- 1 (default)—Enables the CTI alpha blender.

**CTI\_AB[1:0] Chroma Transient Improvement Alpha Blend, Address 0x4D [3:2]**

This controls the behavior of alpha-blend circuitry that mixes the sharpened chroma signal with the original one. It thereby controls the visual impact of CTI on the output data.

For CTI\_AB[1:0] to become active, the CTI block must be enabled via the CTI\_EN bit, and the alpha blender must be switched on via CTI\_AB\_EN.

Sharp blending maximizes the effect of CTI on the picture, but may also increase the visual impact of small amplitude, high frequency chroma noise.

Table 49. CTI\_AB Function

CTI_AB[1:0]	Description
00	Sharpest mixing between sharpened and original chroma signal
01	Sharp mixing
10	Smooth mixing
11 (default)	Smoothest alpha blend function

**CTI\_C\_TH[7:0] CTI Chroma Threshold, Address 0x4E [7:0]**

The CTI\_C\_TH[7:0] value is an unsigned, 8-bit number specifying how big the amplitude step in a chroma transition has to be in order to be steepened by the CTI block. Programming a small value into this register causes even smaller edges to be steepened by the CTI block. Making CTI\_C\_TH[7:0] a large value causes the block to improve large transitions only.

The default value for CTI\_C\_TH[7:0] is 0x08, indicating the threshold for the chroma edges prior to CTI.

**DIGITAL NOISE REDUCTION (DNR), AND LUMA PEAKING FILTER**

DNR is based on the assumption that high frequency signals with low amplitude are probably noise and therefore that their removal improves picture quality. There are two DNR blocks in the ADV7184: the DNR1 block before the luma peaking filter and the DNR2 block after the luma peaking filter, as shown in Figure 23.

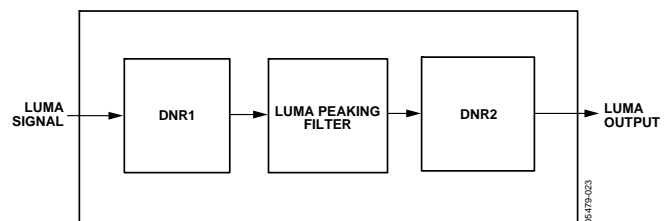

Figure 23. DNR and Peaking Block Diagram

**DNR\_EN Digital Noise Reduction Enable, Address 0x4D [5]**

- 0—Bypasses DNR (disables it).
- 1 (default)— Enables DNR on the luma data.

**DNR\_TH[7:0] DNR Noise Threshold, Address 0x50 [7:0]**

The DNR1 block is positioned before the luma peaking block. The DNR\_TH[7:0] value is an unsigned 8-bit number, which determines the maximum edge that is interpreted as noise and therefore blanked from the luma data. Programming a large value into DNR\_TH[7:0] causes the DNR block to interpret even large transients as noise and remove them. As a result, the effect on the video data is more visible.

Programming a small value causes only small transients to be seen as noise and to be removed.

The recommended DNR\_TH[7:0] setting for A/V inputs is 0x04, and the recommended DNR\_TH[7:0] setting for tuner inputs is 0x0A.

# ADV7184

The default value for DNR\_TH[7:0] is 0x08, indicating the threshold for maximum luma edges to be interpreted as noise.

## PEAKING\_GAIN[7:0], Luma Peaking Gain, Address 0xFB [7:0]

This filter can be manually enabled. The user can boost or attenuate the midregion of the Y spectrum around 3 MHz. The peaking filter can visually improve the picture by showing more definition on the picture details that contain frequency components around 3 MHz. The default value (0x40) in this register passes through the luma data unaltered (0 dB response). A lower value attenuates the signal and a higher value amplifies it. A plot of the filters responses is shown in Figure 24.

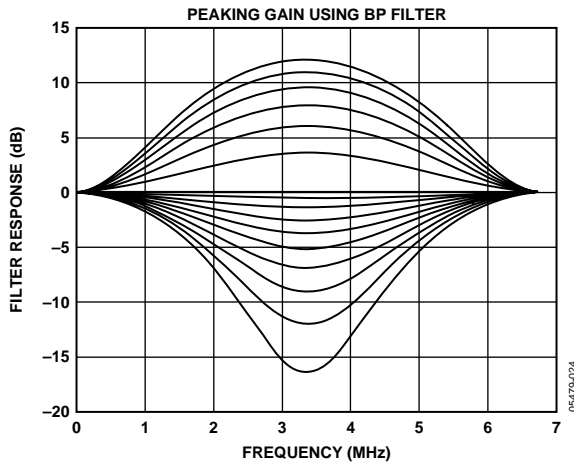

Figure 24. Peaking Filter Responses

## DNR\_TH2[7:0] DNR Noise Threshold 2, Address 0xFC [7:0]

The DNR2 block is positioned after the luma peaking block, so it affects the amplified luma signal. It operates in the same way as the DNR1 block but has an independent threshold control, DNR\_TH2[7:0]. This value is an unsigned 8-bit number, which determines the maximum edge that is still interpreted as noise and, therefore, blanked from the luma data.

Programming a large value into DNR\_TH2[7:0] causes the DNR block to interpret even large transients as noise and remove them. As a result, the effect on the video data is more visible. Programming a small value causes only small transients to be seen as noise and removed.

## COMB FILTERS

The comb filters of the ADV7184 have been greatly improved to automatically handle video of all types, standards, and levels of quality. The NTSC and PAL configuration registers allow the user to customize comb filter operation, depending on which video standard is detected (by autodetection) or selected (by manual programming). In addition to the bits listed in this section, there are some other ADI internal controls; contact ADI for more information.

### NTSC Comb Filter Settings

Used for NTSC-M/J CVBS inputs.

#### NSFSEL[1:0] Split Filter Selection NTSC, Address 0x19 [3:2]

NSFSEL[1:0] selects how much of the overall signal bandwidth is fed to the combs. A narrow bandwidth split filter gives better performance on diagonal lines, but leaves more dot crawl in the final output image. The opposite is true for a wide bandwidth split filter.

Table 50. NSFSEL Function

NSFSEL[1:0]	Description
00 (default)	Narrow
01	Medium
10	Medium
11	Wide

#### CTAPSN[1:0] Chroma Comb Taps NTSC, Address 0x38 [7:6]

Table 51. CTAPSN Function

CTAPSN[1:0]	Description
00	Do not use
01	NTSC chroma comb adapts 3 lines (3 taps) to 2 lines (2 taps)
10 (default)	NTSC chroma comb adapts 5 lines (5 taps) to 3 lines (3 taps)
11	NTSC chroma comb adapts 5 lines (5 taps) to 4 lines (4 taps)

#### CCMN[2:0] Chroma Comb Mode NTSC, Address 0x38 [5:3]

See Table 52.

#### YCMN[2:0] Luma Comb Mode NTSC, Address 0x38 [2:0]

See Table 53.

**Table 52. CCMN Function**

CCMN[2:0]	Description	Configuration
000 (default)	Adaptive comb mode	Adaptive 3-line chroma comb for CTAPSN = 01 Adaptive 4-line chroma comb for CTAPSN = 10 Adaptive 5-line chroma comb for CTAPSN = 11
100	Disable chroma comb	
101	Fixed chroma comb (top lines of line memory)	Fixed 2-line chroma comb for CTAPSN = 01 Fixed 3-line chroma comb for CTAPSN = 10 Fixed 4-line chroma comb for CTAPSN = 11
110	Fixed chroma comb (all lines of line memory)	Fixed 3-line chroma comb for CTAPSN = 01 Fixed 4-line chroma comb for CTAPSN = 10 Fixed 5-line chroma comb for CTAPSN = 11
111	Fixed chroma comb (bottom lines of line memory)	Fixed 2-line chroma comb for CTAPSN = 01 Fixed 3-line chroma comb for CTAPSN = 10 Fixed 4-line chroma comb for CTAPSN = 11

**Table 53. YCMN Function**

YCMN[2:0]	Description	Configuration
000 (default)	Adaptive comb mode	Adaptive 3-line (3 taps) luma comb
100	Disable luma comb	Use low-pass/notch filter; see the Y-Shaping Filter section
101	Fixed luma comb (top lines of line memory)	Fixed 2-line (2 taps) luma comb
110	Fixed luma comb (all lines of line memory)	Fixed 3-line (3 taps) luma comb
111	Fixed luma comb (bottom lines of line memory)	Fixed 2-line (2 taps) luma comb

**PAL Comb Filter Settings**

Used for PAL-B/G/H/I/D, PAL-M, PAL-Combinational N, PAL-60 and NTSC-443 CVBS inputs.

**PSFSEL[1:0] Split Filter Selection PAL, Address 0x19 [1:0]**

PSFSEL[1:0] selects how much of the overall signal bandwidth is fed to the combs. A wide bandwidth split filter eliminates dot crawl, but shows imperfections on diagonal lines. The opposite is true for a narrow bandwidth split filter.

**Table 54. PSFSEL Function**

PSFSEL[1:0]	Description
00	Narrow
01 (default)	Medium
10	Wide
11	Widest

**CTAPSP[1:0] Chroma Comb Taps PAL, Address 0x39 [7:6]**

**Table 55. CTAPSP Function**

CTAPSP[1:0]	Description
00	Do not use.
01	PAL chroma comb adapts 5 lines (3 taps) to 3 lines (2 taps); cancels cross luma only.
10	PAL chroma comb adapts 5 lines (5 taps) to 3 lines (3 taps); cancels cross luma and hue error less well.
11 (default)	PAL chroma comb adapts 5 lines (5 taps) to 4 lines (4 taps); cancels cross luma and hue error well.

**CCMP[2:0] Chroma Comb Mode PAL, Address 0x39 [5:3]**

See Table 56.

**YCMP[2:0] Luma Comb Mode PAL, Address 0x39 [2:0]**

See Table 57.

**Vertical Blank Control**

Each vertical blank control register has the same meaning for the following bits:

- 00—Early by 1 line.
- 10—Delay by 1 line.
- 11—Delay by 2 lines.

01 (default) is described under each register.

**NVBIOLCM[1:0] NTSC VBI Odd Field Luma Comb Mode, Address 0xEB [7:6]**

These bits control the first combed line after VBI on NTSC odd field (luma comb).

01 (default)—SMPTE170-compliant, blank lines 1–20, 264–282, comb half lines.

**NVBIELCM[1:0] NTSC VBI Even Field Luma Comb Mode, Address 0xEB [5:4]**

These bits control the first combed line after VBI on NTSC even field (luma comb).

01 (default)—SMPTE170-compliant, blank lines 1–20, 264–282, comb half lines.

# ADV7184

## PVBIOLCM[1:0] PAL VBI Odd Field Luma Comb Mode, Address 0xEB [3:2]

These bits control the first combed line after VBI on PAL odd field (luma comb).

01 (default)—BT470-compliant, blank lines 624–22, 311–335, comb half lines.

## PVBIELCM[1:0] PAL VBI Even Field Luma Comb Mode, Address 0xEB [1:0]

These bits control the first combed line after VBI on PAL even field (luma comb).

01 (default)—BT470-compliant, blank lines 624–22, 311–335, comb half lines.

## NVBIOLCM[1:0] NTSC VBI Odd Field Chroma Comb Mode, Address 0xEC [7:6]

These bits control the first combed line after VBI on NTSC odd field (chroma comb).

01 (default)—SMPTE170-compliant, no color on lines 1–20, 264–282, chroma present on half lines.

## NVBIELCM[1:0] NTSC VBI Even Field Chroma Comb Mode, Address 0xEC [5:4]

These bits control the first combed line after VBI on NTSC even field (chroma comb).

01 (default)—SMPTE170-compliant, no color on lines 1–20, 264–282, chroma present on half lines.

## PVBIOCCM[1:0] PAL VBI Odd Field Chroma Comb Mode, Address 0xEC [3:2]

These bits control the first combed line after VBI on PAL odd field (chroma comb).

01 (default)—BT470-compliant, no color on lines 624–22, 311–335, chroma present on half lines.

## PVBIELCM[1:0] PAL VBI Even Field Chroma Comb Mode, Address 0xEC [1:0]

These bits control the first combed line after VBI on PAL even field (chroma comb).

01 (default)—BT470-compliant, no color on lines 624–22, 311–335, chroma present on half lines.

**Table 56. CCMP Function**

CCMP[2:0]	Description	Configuration
000 (default)	Adaptive comb mode	Adaptive 3-line chroma comb for CTAPSP = 01 Adaptive 4-line chroma comb for CTAPSP = 10 Adaptive 5-line chroma comb for CTAPSP = 11
100	Disable chroma comb.	
101	Fixed chroma comb (top lines of line memory)	Fixed 2-line chroma comb for CTAPSP = 01 Fixed 3-line chroma comb for CTAPSP = 10 Fixed 4-line chroma comb for CTAPSP = 11
110	Fixed chroma comb (all lines of line memory)	Fixed 3-line chroma comb for CTAPSP = 01 Fixed 4-line chroma comb for CTAPSP = 10 Fixed 5-line chroma comb for CTAPSP = 11
111	Fixed chroma comb (bottom lines of line memory)	Fixed 2-line chroma comb for CTAPSP = 01 Fixed 3-line chroma comb for CTAPSP = 10 Fixed 4-line chroma comb for CTAPSP = 11

**Table 57. YCMP Function**

YCMP[2:0]	Description	Configuration
000 (default)	Adaptive comb mode	Adaptive 5 lines (3 taps) luma comb
100	Disable luma comb	Use low-pass/notch filter; see the Y-Shaping Filter section
101	Fixed luma comb (top lines of line memory)	Fixed 3 lines (2 taps) luma comb
110	Fixed luma comb (all lines of line memory)	Fixed 5 lines (3 taps) luma comb
111	Fixed luma comb (bottom lines of line memory)	Fixed 3 lines (2 taps) luma comb

### AV CODE INSERTION AND CONTROLS

This section describes the I<sup>2</sup>C-based controls that affect

- Insertion of AV codes into the data stream
- Data blanking during the vertical blank interval (VBI)
- The range of data values permitted in the output data stream
- The relative delay of luma vs. chroma signals

Note that some of the decoded VBI data is being inserted during the horizontal blanking interval. See the Gemstar Data Recovery section for more information.

#### BT656-4 ITU Standard BT-R.656-4 Enable, Address 0x04 [7]

The ITU has changed the position for toggling the V bit within the SAV EAV codes for NTSC between revisions 3 and 4. The BT656-4 standard bit allows the user to select an output mode that is compliant with either the previous or the new standard. For more information, review the standard at <http://www.itu.int>.

Note that the standard change affects NTSC only and has no bearing on PAL.

0 (default)—The BT656-3 specification is used. The V bit goes low at EAV of Lines 10 and 273.

1—The BT656-4 specification is used. The V bit goes low at EAV of Lines 20 and 283.

#### SD\_DUP\_AV Duplicate AV Codes, Address 0x03 [0]

Depending on the output interface width, it may be necessary to duplicate the AV codes from the luma path into the chroma path.

In an 8-bit-wide output interface (Cb/Y/Cr/Y interleaved data), the AV codes are defined as FF/00/00/AV, with AV being the transmitted word that contains information about H/V/F. In this output interface mode, the following assignment takes place: Cb = FF, Y = 00, Cr = 00, and Y = AV.

In a 16-bit output interface where Y and Cr/Cb are delivered via separate data buses, the AV code is over the whole 16 bits. The SD\_DUP\_AV bit allows the user to replicate the AV codes on both buses, so the full AV sequence can be found on the Y bus and on the Cr/Cb bus. See Figure 25.

0 (default)—The AV codes are in single fashion (to suit 8-bit interleaved data output).

1—The AV codes are duplicated (for 16-bit interfaces).

#### VBI\_EN Vertical Blanking Interval Data Enable, Address 0x03 [7]

The VBI enable bit allows data such as intercast and closed caption data to be passed through the luma channel of the decoder with a minimal amount of filtering. All data for Line 1 to Line 21 is passed through and available at the output port. The ADV7184 does not blank the luma data, and automatically switches all filters along the luma data path into their widest bandwidth. For active video, the filter settings for YSH and YPK are restored.

Refer to the BL\_C\_VBI Blank Chroma during VBI, Address 0x04 [2] section for information on the chroma path.

0 (default)—All video lines are filtered/scaled.

1—Only the active video region is filtered/scaled.

#### BL\_C\_VBI Blank Chroma during VBI, Address 0x04 [2]

When BL\_C\_VBI is set high, the Cr and Cb values of all VBI lines are blanked. This is done so any data that may arrive during VBI is not decoded as color and output through Cr and Cb. As a result, it is possible to send VBI lines into the decoder, then output them through an encoder again, undistorted. Without this blanking, any wrongly decoded color is encoded by the video encoder; therefore, the VBI lines are distorted.

0—Decodes and outputs color during VBI.

1 (default)—Blanks Cr and Cb values during VBI.

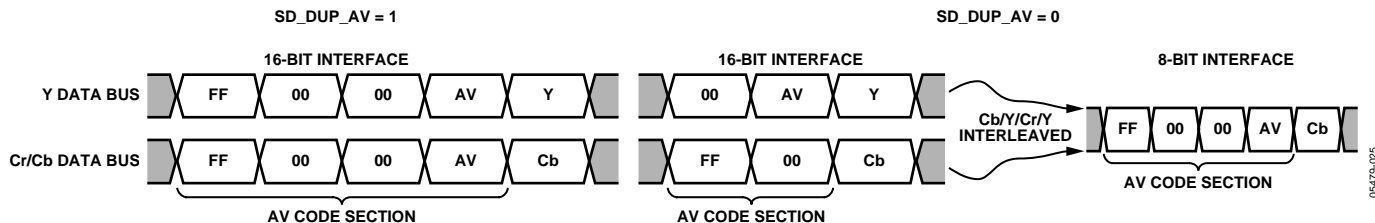

Figure 25. AV Code Duplication Control

# ADV7184

## RANGE Range Selection, Address 0x04 [0]

AV codes (as per ITU-R BT-656, formerly known as CCIR-656) consist of a fixed header made up of 0xFF and 0x00 values. These two values are reserved and therefore not to be used for active video. Additionally, the ITU specifies that the nominal range for video should be restricted to values between 16 and 235 for luma and 16 to 240 for chroma.

The RANGE bit allows the user to limit the range of values output by the ADV7184 to the recommended value range. In any case, it ensures that the reserved values of 255d (0xFF) and 00d (0x00) are not presented on the output pins unless they are part of an AV code header.

**Table 58. RANGE Function**

RANGE	Description	
0	$16 \leq Y \leq 235$	$16 \leq C \leq 240$
1 (default)	$1 \leq Y \leq 254$	$1 \leq C \leq 254$

## AUTO\_PDC\_EN Automatic Programmed Delay Control, Address 0x27 [6]

Enabling the AUTO\_PDC\_EN function activates a function within the ADV7184 that automatically programs LTA[1:0] and CTA[2:0] to have the chroma and luma data match delays for all modes of operation.

0—The ADV7184 uses the LTA[1:0] and CTA[2:0] values for delaying luma and chroma samples. Refer to the LTA[1:0] Luma Timing Adjust, Address 0x27 [1:0] and the CTA[2:0] Chroma Timing Adjust, Address 0x27 [5:3] sections.

1 (default)—The ADV7184 automatically programs the LTA and CTA values to have luma and chroma aligned at the output. Manual registers LTA[1:0] and CTA[2:0] are not used.

## LTA[1:0] Luma Timing Adjust, Address 0x27 [1:0]

This register allows the user to specify a timing difference between chroma and luma samples.

Note that there is a certain functionality overlap with the CTA[2:0] register. For manual programming, use the following defaults:

- CVBS input LTA[1:0] = 00
- YC input LTA[1:0] = 01
- YPrPb input LTA[1:0] = 01

**Table 59. LTA Function**

LTA[1:0]	Description
00 (default)	No delay
01	Luma 1 clk (37 ns) delayed
10	Luma 2 clk (74 ns) early
11	Luma 1 clk (37 ns) early

## CTA[2:0] Chroma Timing Adjust, Address 0x27 [5:3]

This register allows the user to specify a timing difference between chroma and luma samples. This may be used to compensate for external filter group delay differences in the luma vs. chroma path, and to allow a different number of pipeline delays while processing the video downstream. Review this functionality together with the LTA[1:0] register.

The chroma can only be delayed/advanced in chroma pixel steps. One chroma pixel step is equal to two luma pixels. The programmable delay occurs after demodulation, where one can no longer delay by luma pixel steps.

For manual programming, use the following defaults:

- CVBS input CTA[2:0] = 011
- YC input CTA[2:0] = 101
- YPrPb input CTA[2:0] = 110

**Table 60. CTA Function**

CTA[2:0]	Description
000	Not used
001	Chroma + 2 chroma pixel (early)
010	Chroma + 1 chroma pixel (early)
011 (default)	No delay
100	Chroma – 1 chroma pixel (late)
101	Chroma – 2 chroma pixel (late)
110	Chroma – 3 chroma pixel (late)
111	Not used

## SYNCHRONIZATION OUTPUT SIGNALS

### HS Configuration

The following controls allow the user to configure the behavior of the HS output pin only:

- Beginning of HS signal via HSB[10:0]
- End of HS signal via HSE[10:0]
- Polarity of HS using PHS

The HS begin and HS end registers allow the user to freely position the HS output (pin) within the video line. The values in HSB[10:0] and HSE[10:0] are measured in pixel units from the falling edge of HS. Using both values, the user can program both the position and length of the HS output signal.

### HSB[10:0] HS Begin, Address 0x34 [6:4], Address 0x35 [7:0]

The position of this edge is controlled by placing a binary number into HSB[10:0]. The number applied offsets the edge with respect to an internal counter that is reset to 0 immediately after EAV code FF, 00, 00, XY (see Figure 26). HSB[10:0] is set to 0000000010, which is 2 LLC1 clock cycles from count[0].

The default value of HSB[10:0] is 0x002, indicating that the HS pulse starts two pixels after the falling edge of HS.

Table 61. HS Timing Parameters

Standard	Characteristic				
	HS Begin Adjust (HSB[10:0]) (default)	HS End Adjust (HSE[10:0]) (default)	HS to Active Video (LLC1 Clock Cycles) (C in Figure 26) (default)	Active Video Samples/Line (D in Figure 26)	Total LLC1 Clock Cycles (E in Figure 26)
NTSC	0000000010	0000000000	272	720Y + 720C = 1440	1716
NTSC Square Pixel	0000000010	0000000000	276	640Y + 640C = 1280	1560
PAL	0000000010	0000000000	284	720Y + 720C = 1440	1728

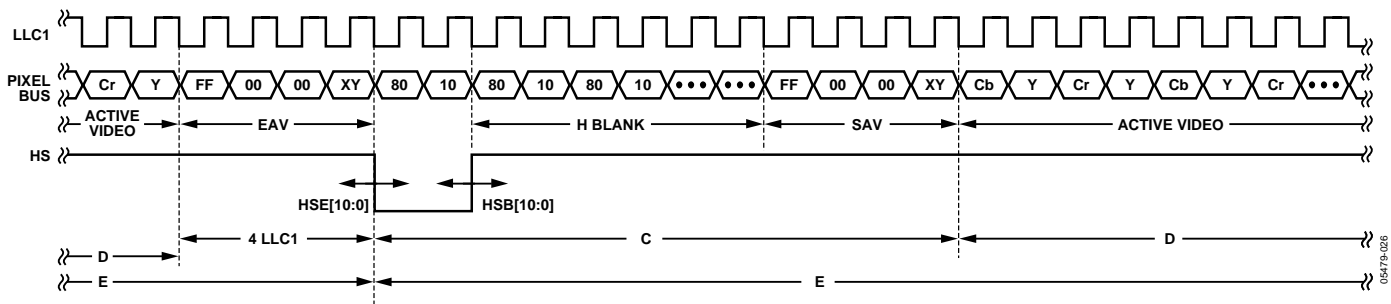

Figure 26. HS Timing

**HSE[10:0] HS End, Address 0x34 [2:0]; Address 0x36 [7:0]**

The position of this edge is controlled by placing a binary number into HSE[10:0]. The number applied offsets the edge with respect to an internal counter that is reset to 0 immediately after EAV code FF, 00, 00, XY (see Figure 26). HSE is set to 0000000000, which is 0 LLC1 clock cycles from count[0].

The default value of HSE[10:0] is 000, indicating that the HS pulse ends 0 pixels after falling edge of HS.

For example:

- To shift the HS toward active video by 20 LLC1s, add 20 LLC1s to both HSB and HSE, that is, HSB[10:0] = [00000010110], HSE[10:0] = [00000010100].
- To shift the HS away from active video by 20 LLC1s, add 1696 LLC1s to both HSB and HSE (for NTSC), that is, HSB[10:0] = [11010100010], HSE[10:0] = [11010100000]. 1696 is derived from the NTSC total number of pixels = 1716.

To move 20 LLC1s away from active video is equal to subtracting 20 from 1716 and adding the result in binary to both HSB[10:0] and HSE[10:0].

**PHS Polarity HS, Address 0x37 [7]**

The polarity of the HS pin can be inverted using the PHS bit.

- 0 (default)—HS is active high.
- 1—HS is active low.

**VS and FIELD Configuration**

The following controls allow the user to configure the behavior of the VS and FIELD output pins, as well as to generate embedded AV codes:

- ADV encoder-compatible signals via NEWAVMODE
- PVS, PF
- HVSTIM
- VSBHO, VSBHE
- VSEHO, VSEHE
- For NTSC control:
  - NVBEGDELO, NVBEGDELE, NVBEGSIGN, NVBEG[4:0]
  - NVENDDELO, NVENDDELE, NVENDSIGN, NVEND[4:0]
  - NFTOGDELO, NFTOGDELE, NFTOGSIGN, NFTOG[4:0]
- For PAL control:
  - PVBEGDELO, PVBEGDELE, PVBEGSIGN, PVBEG[4:0]
  - PVENDDELO, PVENDDELE, PVENDSIGN, PVEND[4:0]
  - PFTOGDELO, PFTOGDELE, PFTOGSIGN, PFTOG[4:0]

# ADV7184

## NEWAVMODE New AV Mode, Address 0x31 [4]

0—EAV/SAV codes are generated to suit ADI encoders. No adjustments are possible.

1 (default)—Enables the manual position of the VSYNC, Field, and AV codes using Register 0x34 to Register 0x37 and Register 0xE5 to Register 0xEA. Default register settings are CCIR656-compliant; see Figure 27 for NTSC and Figure 32 for PAL. For recommended manual user settings, see Table 62 and Figure 28 for NTSC; see Table 63 and Figure 33 for PAL.

**Table 62. Recommended User Settings for NTSC**  
(See Figure 28)

Register	Register Name	Write
0x31	VSYNC Field Control 1	0x1A
0x32	VSYNC Field Control 2	0x81
0x33	VSYNC Field Control 3	0x84
0x34	HSYNC Position 1	0x00
0x35	HSYNC Position 2	0x00
0x36	HSYNC Position 3	0x7D
0x37	Polarity	0xA1
0xE5	NTSV_V_Bit_Beg	0x41
0xE6	NTSC_V_Bit_End	0x84
0xE7	NTSC_F_Bit_Tog	0x06

## HVSTIM Horizontal VS Timing, Address 0x31 [3]

The HVSTIM bit allows the user to select where the VS signal is being asserted within a line of video. Some interface circuitry may require VS to go low while HS is low.

0 (default)—The start of the line is relative to HSE.

1—The start of the line is relative to HSB.

## VSBO VS Begin Horizontal Position Odd, Address 0x32 [7]

This bit selects the position within a line at which the VS pin (not the bit in the AV code) becomes active. Some follow-on chips require the VS pin to change state only when HS is high/low.

0 (default)—The VS pin goes high at the middle of a line of video (odd field).

1—The VS pin changes state at the start of a line (odd field).

## VSBE VS Begin Horizontal Position Even, Address 0x32 [6]

This bit selects the position within a line at which the VS pin (not the bit in the AV code) becomes active. Some follow-on chips require the VS pin to change state when only HS is high/low.

0—The VS pin goes high at the middle of a line of video (even field).

1 (default)—The VS pin changes state at the start of a line (even field).

## VSBO VS End Horizontal Position Odd, Address 0x33 [7]

This bit selects the position within a line at which the VS pin (not the bit in the AV code) becomes inactive. Some follow-on chips require the VS pin to change state only when HS is high/low.

0—The VS pin goes low (inactive) at the middle of a line of video (odd field).

1 (default)—The VS pin changes state at the start of a line (odd field).

## VSBE VS End Horizontal Position Even, Address 0x33 [6]

This bit selects the position within a line at which the VS pin (not the bit in the AV code) becomes inactive. Some follow-on chips require the VS pin to change state only when HS is high/low.

0 (default)—The VS pin goes low (inactive) at the middle of a line of video (even field).

1—The VS pin changes state at the start of a line (even field).

## PVS Polarity VS, Address 0x37 [5]

The polarity of the VS pin can be inverted using the PVS bit.

0 (default)—VS is active high.

1—VS is active low.

## PF Polarity FIELD, Address 0x37 [3]

The polarity of the FIELD pin can be inverted using the PF bit.

0 (default)—FIELD is active high.

1—FIELD is active low.

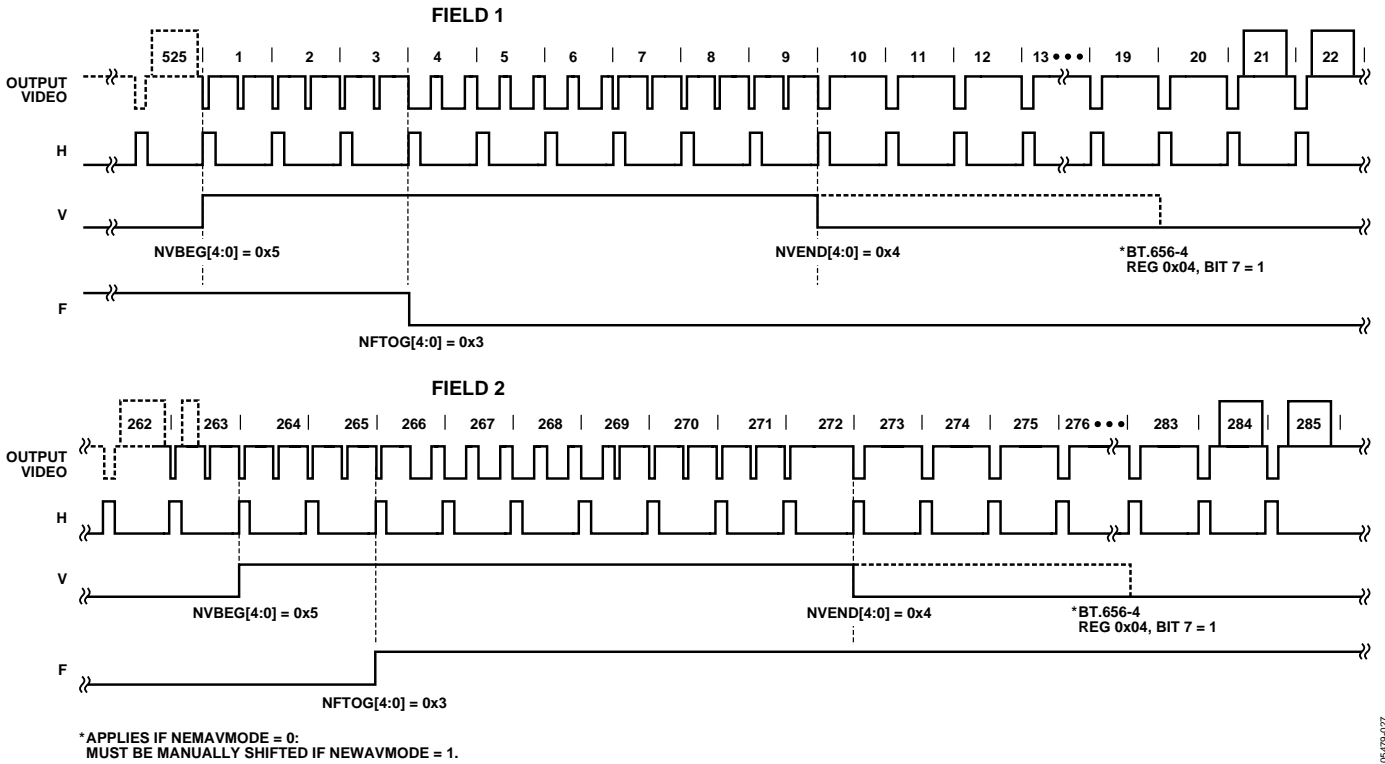

Figure 27. NTSC Default (BT.656). The Polarity of H, V, and F is Embedded in the Data.

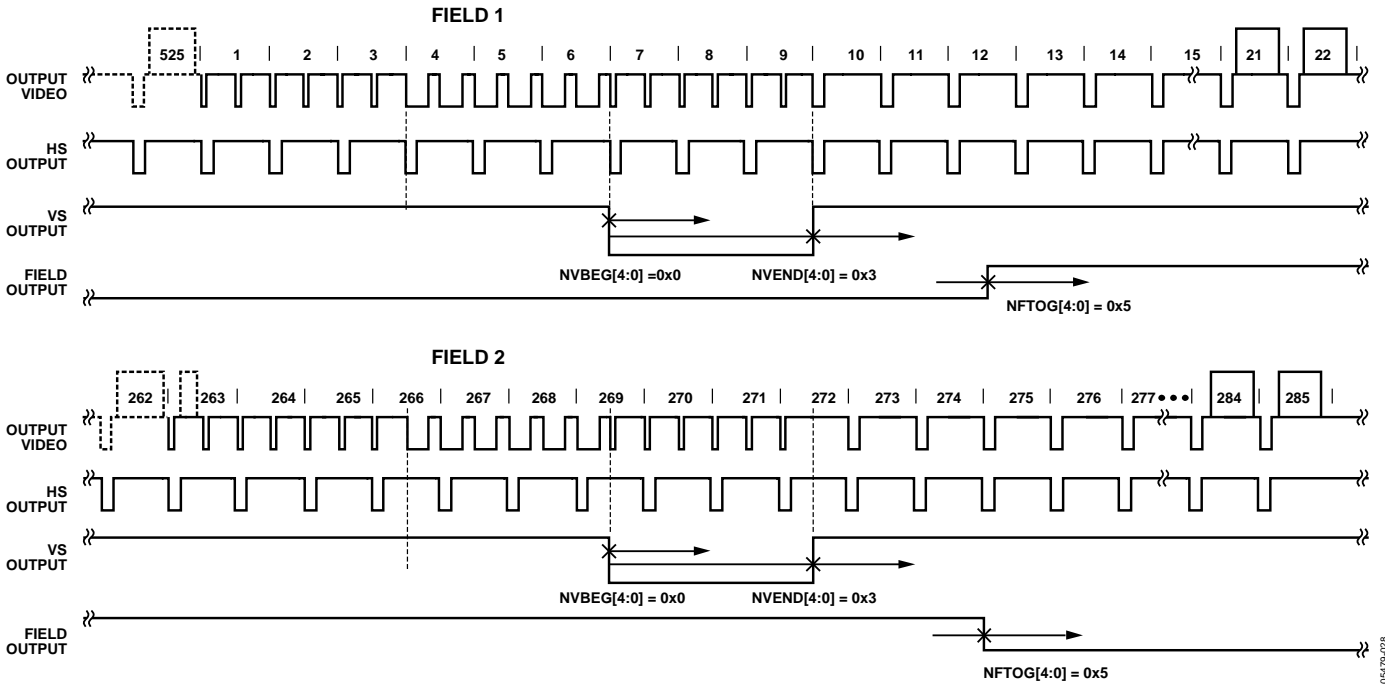

Figure 28. NTSC Typical VSYNC/Field Positions Using Register Writes in Table 62

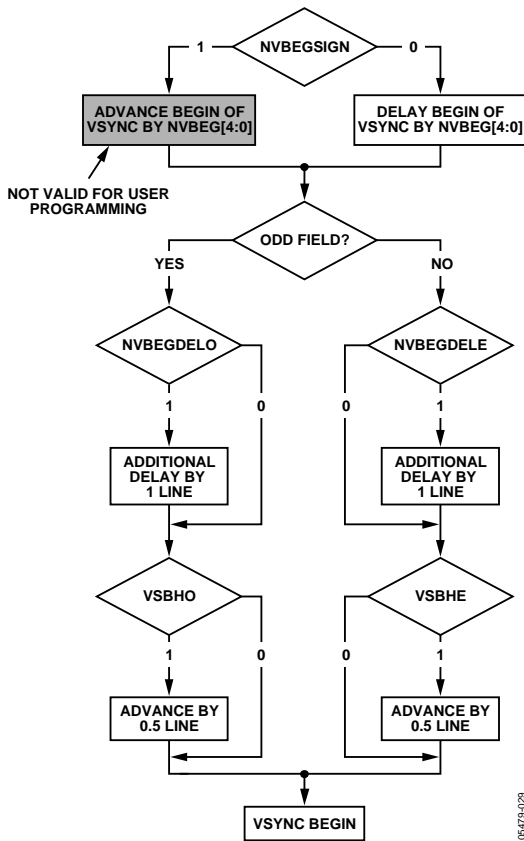

Figure 29. NTSC VSYNC Begin

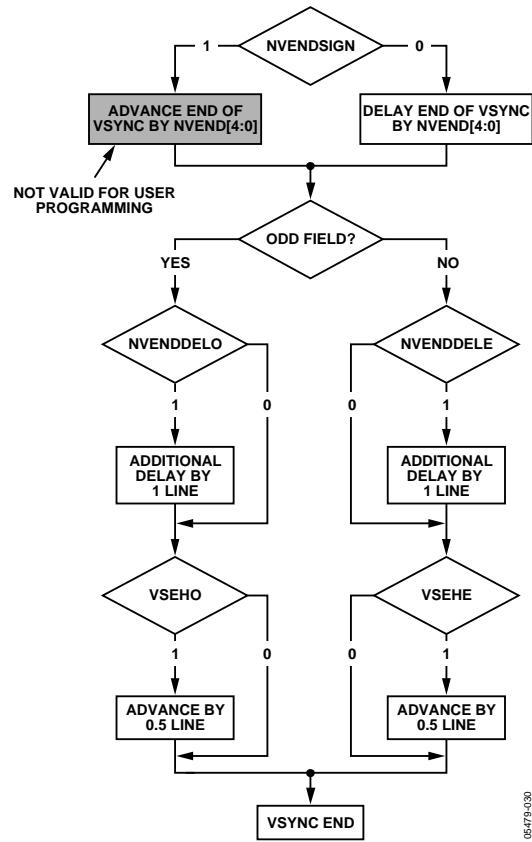

Figure 30. NTSC VSYNC End

**NVBEGDELO NTSC VSYNC Begin Delay on Odd Field, Address 0xE5 [7]**

0 (default)—No delay.

1—Delays VSYNC going high on an odd field by a line relative to NVBEG.

**NVBEGDELE NTSC VSYNC Begin Delay on Even Field, Address 0xE5 [6]**

0 (default)—No delay.

1—Delays VSYNC going high on an even field by a line relative to NVBEG.

**NVBEGSIGN NTSC VSYNC Begin Sign, Address 0xE5 [5]**

0—Delays the start of VSYNC. Set for user manual programming.

1 (default)—Advances the start of VSYNC. Not recommended for user programming.

**NVBEG[4:0] NTSC VSYNC Begin, Address 0xE5 [4:0]**

The default value of NVBEG is 00101, indicating the NTSC VSYNC begin position. For all NTSC/PAL VSYNC timing controls, both the V bit in the AV code and the VSYNC on the VS pin are modified.

**NVENDDELO NTSC VSYNC End Delay on Odd Field, Address 0xE6 [7]**

0 (default)—No delay.

1—Delays VSYNC from going low on an odd field by a line relative to NVEND.

**NVENDDELE NTSC VSYNC End Delay on Even Field, Address 0xE6 [6]**

0 (default)—No delay.

1—Delays VSYNC from going low on an even field by a line relative to NVEND.

**NVENDSIGN NTSC VSYNC End Sign, Address 0xE6 [5]**

0 (default)—Delays the end of VSYNC. Set for user manual programming.

1—Advances the end of VSYNC. Not recommended for user programming.

**NVEND[4:0] NTSC VSYNC End, Address 0xE6 [4:0]**

The default value of NVEND is 00100, indicating the NTSC VSYNC end position.

For all NTSC/PAL VSYNC timing controls, both the V bit in the AV code and the VSYNC on the VS pin are modified.

**NFTOGDELO NTSC Field Toggle Delay on Odd Field, Address 0xE7 [7]**

0 (default)—No delay.

1—Delays the field toggle/transition on an odd field by a line relative to NFTOG.

**NFTOGDELE NTSC Field Toggle Delay on Even Field, Address 0xE7 [6]**

0—No delay.

1 (default)—Delays the field toggle/transition on an even field by a line relative to NFTOG.

**NFTOGSIGN NTSC Field Toggle Sign, Address 0xE7 [5]**

0—Delays the field transition. Set for user manual programming.

1 (default)—Advances the field transition. Not recommended for user programming.

**NFTOG[4:0] NTSC Field Toggle, Address 0xE7 [4:0]**

The default value of NFTOG is 00011, indicating the NTSC Field toggle position.

For all NTSC/PAL field timing controls, both the F bit in the AV code and the field signal on the FIELD/DE pin are modified.

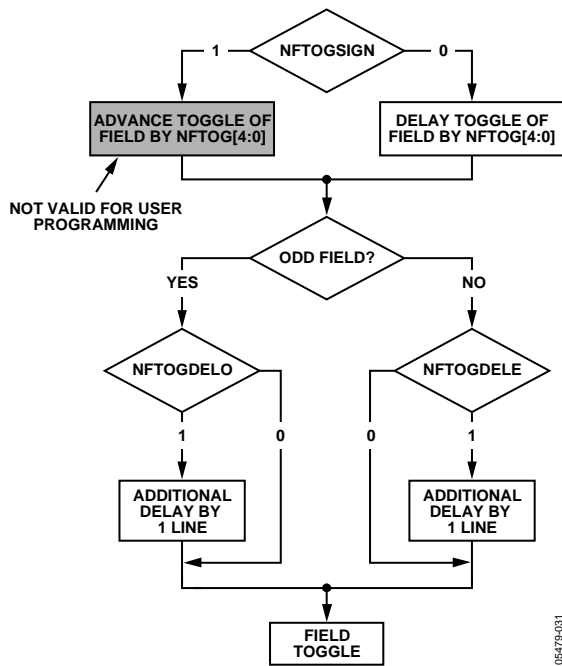

Figure 31. NTSC FIELD Toggle

**PVBEGDELO PAL VSYNC Begin Delay on Odd Field, Address 0xE8 [7]**

0 (default)—No delay.

1—Delays VSYNC going high on an odd field by a line relative to PVBEG.

**PVBEGDELE PAL VSYNC Begin Delay on Even Field, Address 0xE8 [6]**

0 (default)—No delay.

1 (default)—Delays VSYNC going high on an even field by a line relative to PVBEG.

**PVBEGSIGN PAL VSYNC Begin Sign, Address 0xE8 [5]**

0—Delays the beginning of VSYNC. Set for user manual programming.

1 (default)—Advances the beginning of VSYNC. Not recommended for user programming.

**PVBEG[4:0] PAL VSYNC Begin, Address 0xE8 [4:0]**

The default value of PVBEG is 00101, indicating the PAL VSYNC begin position.

For all NTSC/PAL VSYNC timing controls, both the V bit in the AV code and the VSYNC on the VS pin are modified.

Table 63. Recommended User Settings for PAL (see Figure 33)

Register	Register Name	Write
0x31	VSYNC Field Control 1	0x1A
0x32	VSYNC Field Control 2	0x81
0x33	VSYNC Field Control 3	0x84
0x34	HSYNC Position 1	0x00
0x35	HSYNC Position 2	0x00
0x36	HSYNC Position 3	0x7D
0x37	Polarity	0xA1
0xE8	PAL_V_Bit_Beg	0x41
0xE9	PAL_V_Bit_End	0x84
0xEA	PAL_F_Bit_Tog	0x06

# ADV7184

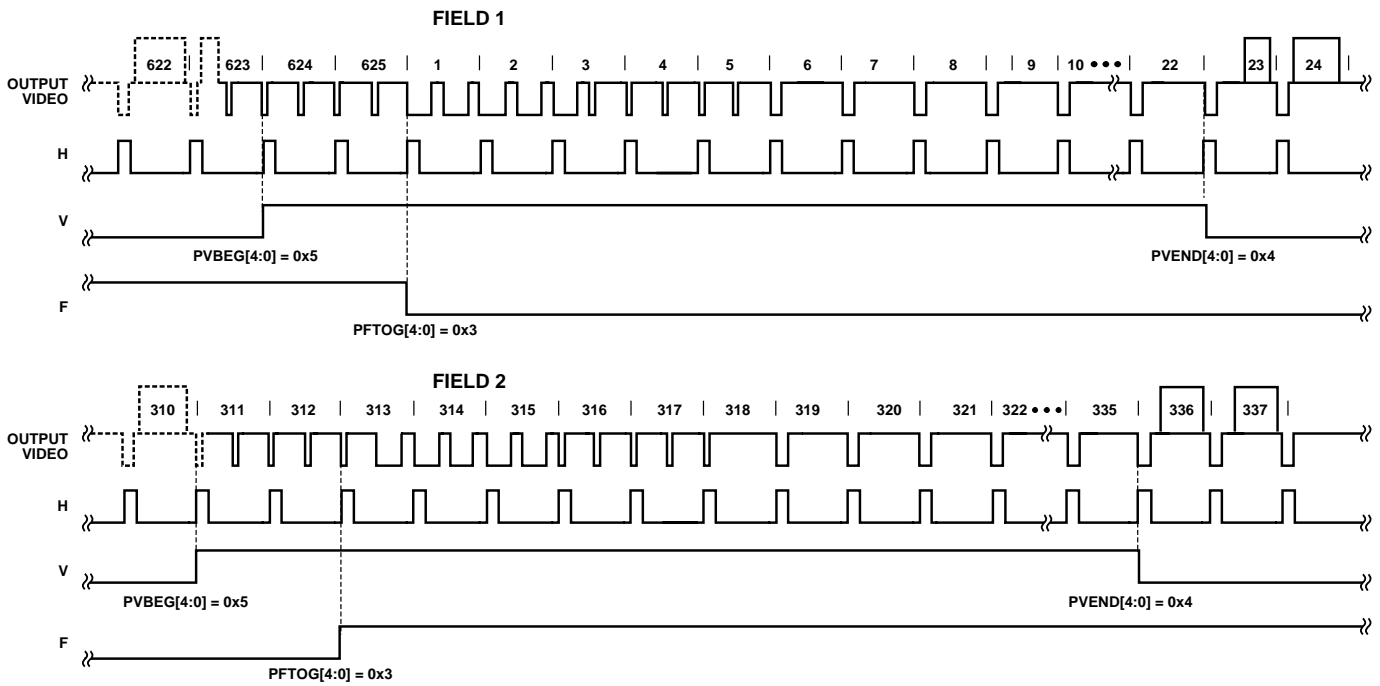

Figure 32. PAL Default (BT.656). The Polarity of H, V, and F is Embedded in the Data.

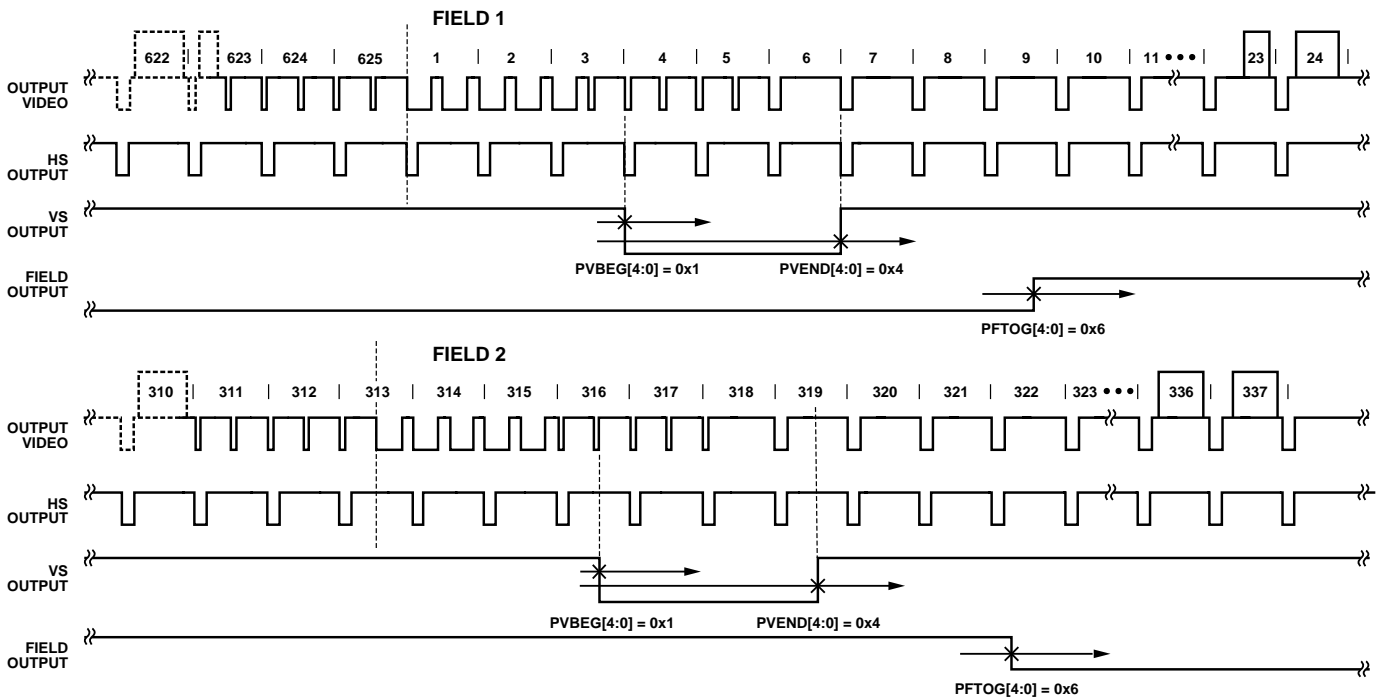

Figure 33. PAL Typical VSYNC/Field Positions Using Register Writes in Table 63

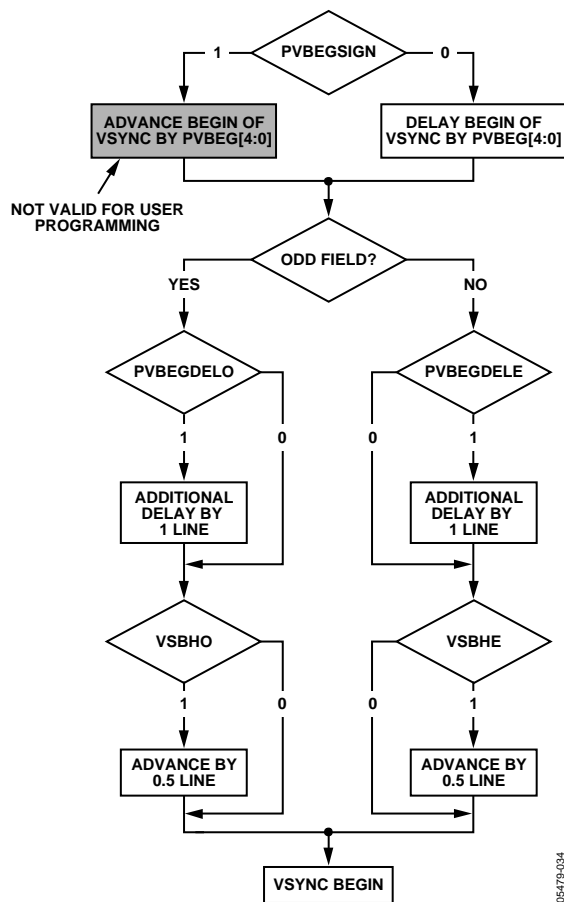

Figure 34. PAL VSYNC Begin

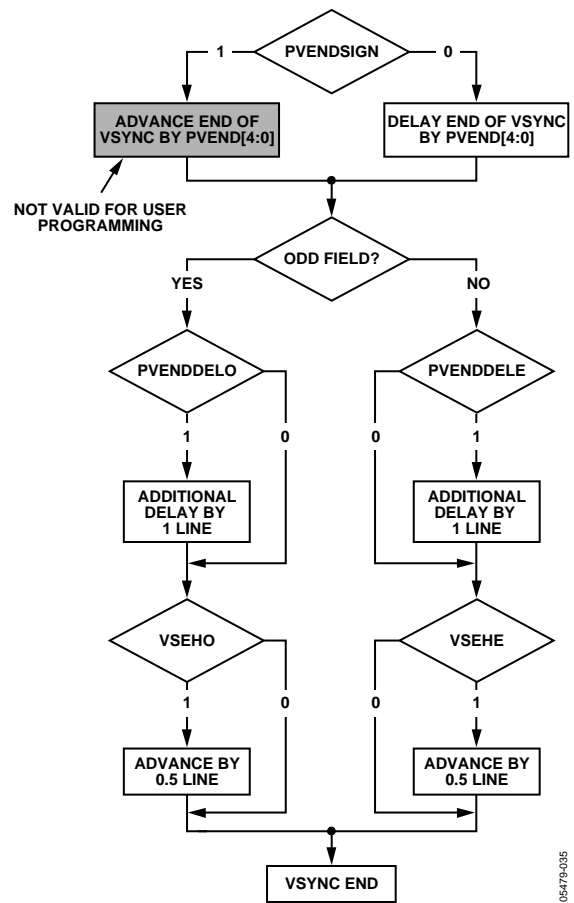

Figure 35. PAL VSYNC End

**PVENDDELO PAL VSYNC End Delay on Odd Field, Address 0xE9 [7]**

0 (default)—No delay.

1—Delays VSYNC going low on an odd field by a line relative to PVEND.

**PVENDDELE PAL VSYNC End Delay on Even Field, Address 0xE9 [6]**

0 (default)—No delay.

1—Delays VSYNC going low on an even field by a line relative to PVEND.

**PVENDSIGN PAL VSYNC End Sign, Address 0xE9 [5]**

0 (default)—Delays the end of VSYNC. Set for user manual programming.

1—Advances the end of VSYNC. Not recommended for user programming.

**PVEND[4:0] PAL VSYNC End, Address 0xE9 [4:0]**

The default value of PVEND is 10100, indicating the PAL VSYNC end position.

For all NTSC/PAL VSYNC timing controls, both the V bit in the AV code and the VSYNC on the VS pin are modified.

**PFTOGDELO PAL Field Toggle Delay on Odd Field, Address 0xEA [7]**

0 (default)—No delay.

1—Delays the F toggle/transition on an odd field by a line relative to PFTOG.

**PFTOGDELE PAL Field Toggle Delay on Even Field, Address 0xEA [6]**

0 (default)—No delay.

1 (default)—Delays the F toggle/transition on an even field by a line relative to PFTOG.

# ADV7184

## PFTOFSIGN PAL Field Toggle Sign, Address 0xEA [5]

0—Delays the field transition. Set for user manual programming.

1 (default)—Advances the field transition. Not recommended for user programming.

## PFTOG PAL Field Toggle, Address 0xEA [4:0]

The default value of PFTOG is 00011, indicating the PAL field toggle position.

For all NTSC/PAL field timing controls, the F bit in the AV code and the field signal on the FIELD/DE pin are modified.

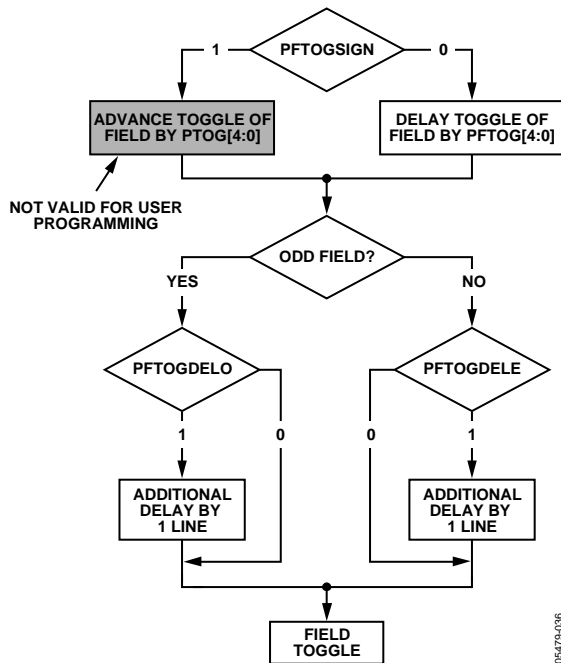

Figure 36. PAL F Toggle

## SYNC PROCESSING

The ADV7184 has two additional sync processing blocks that postprocess the raw synchronization information extracted from the digitized input video. If desired, the blocks can be disabled via the following two I<sup>2</sup>C bits.

### ENHSPLL Enable HSYNC Processor, Address 0x01 [6]

The HSYNC processor is designed to filter incoming HSYNCs that have been corrupted by noise, providing improved performance for video signals with stable time bases but poor SNR.

0—Disables the HSYNC processor.

1 (default)—Enables the HSYNC processor.

### ENVSPROC Enable VSYNC Processor, Address 0x01 [3]

This block provides extra filtering of the detected VSYNCs to give improved vertical lock.

0—Disables the VSYNC processor.

1 (default)—Enables the VSYNC processor.

## VBI DATA DECODE

There are two VBI data slicers on the ADV7184. The first is called the VBI data processor (VDP) and the second is called VBI System 2.

The VDP can slice both low bandwidth standards and high bandwidth standards such as teletext. VBI System 2 can slice low data-rate VBI standards only.

The VDP is capable of slicing multiple VBI data standards on SD video. It decodes the VBI data on the incoming CVBS/YC or YUV data. The decoded results are available as ancillary data in output 656 data stream. For low data rate VBI standards like CC/WSS/CGMS the user can read the decoded data bytes from I<sup>2</sup>C registers.

The VBI data standards that can be decoded by the VDP are:

### PAL

Teletext System A or C or D	ITU-BT-653
Teletext System B/WST	ITU-BT-653
VPS (Video Programming System)	ETSI EN 300 231 V 1.3.1
VITC (Vertical Interval Time Codes)	
WSS (Wide Screen Signaling)	BT.1119-1/ ETSI.EN.300294

CCAP (Closed Captioning)

### NTSC

Teletext System B and D	ITU-BT-653
Teletext System C/NABTS	ITU-BT-653/EIA-516
VITC (Vertical Interval Time Codes)	
CGMS (Copy Generation Management System)	EIA-J CPR-1204/IEC 61880
GEMSTAR	
CCAP (Closed Captioning)	EIA-608

The VBI data standard that the VDP decodes on a particular line of incoming video has been set by default as described in Table 64. This can be overridden manually and any VBI data can be decoded on any line. The details of manual programming are described in Table 65 and Table 66.

**VDP Default Configuration**

The VDP can decode different VBI data standards on a line-to-line basis. The various standards supported by default on different lines of VBI are explained in Table 64.

**VDP Manual Configuration**

**MAN\_LINE\_PGM Enable Manual Line Programming of VBI Standards, Address 0x64 [7] User Sub Map**

The user can configure the VDP to decode different standards on a line-to-line basis through manual line programming. For this, the user has to set the MAN\_LINE\_PGM bit. The user needs to write into all the line programming registers VBI\_DATA\_Px\_Ny (Register 0x64 to Register 0x77, User Sub Map).

0 (default)—The VDP decodes default standards on lines as shown in Table 64.

1—VBI standards to be decoded are manually programmed.

**VBI\_DATA\_Px\_Ny [3:0] VBI Standard to be Decoded on Line x for PAL, Line y for NTSC, Address 0x64-0x77, User Sub Map**

These are related 4-bit clusters contained from Register 0x64 to Register 0x77 in the User Sub Map. The 4-bit, line programming registers, named VBI\_DATA\_Px\_Ny, identifies the VBI data standard that would be decoded on line number X in PAL or on line number Y in NTSC mode. The different types of VBI standards decoded by VBI\_DATA\_Px\_Ny are shown in Table 65. Note that the interpretation of its value depends on whether the ADV7184 is in PAL or NTSC mode.

**Table 64. Default Standards on Lines for PAL and NTSC**

PAL – 625/50				NTSC – 525/60			
Line No.	Default VBI DATA Decoded	Line No.	Default VBI DATA Decoded	Line No.	Default VBI DATA Decoded	Line No.	Default VBI DATA Decoded
6	WST	318	VPS	23	Gemstar-1x	–	–
7	WST	319	WST	24	Gemstar-1x	286	Gemstar-1x
8	WST	320	WST	25	Gemstar-1x	287	Gemstar-1x
9	WST	321	WST	–	–	288	Gemstar-1x
10	WST	322	WST	–	–	–	–
11	WST	323	WST	–	–	–	–
12	WST	324	WST	10	NABTS	272	NABTS
13	WST	325	WST	11	NABTS	273	NABTS
14	WST	326	WST	12	NABTS	274	NABTS
15	WST	327	WST	13	NABTS	275	NABTS
16	VPS	328	WST	14	VITC	276	NABTS
17	–	329	VPS	15	NABTS	277	VITC
18	–	330	–	16	VITC	278	NABTS
19	VITC	331	–	17	NABTS	279	VITC
20	WST	332	VITC	18	NABTS	280	NABTS
21	WST	333	WST	19	NABTS	281	NABTS
22	CCAP	334	WST	20	CGMS	282	NABTS
23	WSS	335	CCAP	21	CCAP	283	CGMS
24 + Full ODD Field	WST	336	WST	22 + Full ODD Field	NABTS	284	CCAP
		337 + Full EVEN Field	WST			285 + Full EVEN Field	NABTS

**Table 65. VBI Data Standards—Manual Configuration**

VBI_DATA_Px_Ny	625/50 – PAL	525/60 – NTSC
0000	Disable VDP.	Disable VDP.
0001	Teletext system identified by VDP_TTXT_TYPE.	Teletext system identified by VDP_TTXT_TYPE.
0010	VPS – ETSI EN 300 231 V 1.3.1.	Reserved.
0011	VITC.	VITC.
0100	WSS BT.1119-1/ETSI.EN.300294.	CGMS EIA-J CPR-1204/IEC 61880.
0101	Reserved.	Gemstar_1X.
0110	Reserved.	Gemstar_2X.
0111	CCAP.	CCAP EIA-608.
1000 – 1111	Reserved.	Reserved.

# ADV7184

**Table 66. VBI Data Standards to be Decoded on Line Px (PAL) or Line Ny (NTSC)**

Signal Name	Register Location	Address	
		Dec	Hex
VBI_DATA_P6_N23	VDP_LINE_00F[7:4]	101	0x65
VBI_DATA_P7_N24	VDP_LINE_010[7:4]	102	0x66
VBI_DATA_P8_N25	VDP_LINE_011[7:4]	103	0x67
VBI_DATA_P9	VDP_LINE_012[7:4]	104	0x68
VBI_DATA_P10	VDP_LINE_013[7:4]	105	0x69
VBI_DATA_P11	VDP_LINE_014[7:4]	106	0x6A
VBI_DATA_P12_N10	VDP_LINE_015[7:4]	107	0x6B
VBI_DATA_P13_N11	VDP_LINE_016[7:4]	108	0x6C
VBI_DATA_P14_N12	VDP_LINE_017[7:4]	109	0x6D
VBI_DATA_P15_N13	VDP_LINE_018[7:4]	110	0x6E
VBI_DATA_P16_N14	VDP_LINE_019[7:4]	111	0x6F
VBI_DATA_P17_N15	VDP_LINE_01A[7:4]	112	0x70
VBI_DATA_P18_N16	VDP_LINE_01B[7:4]	113	0x71
VBI_DATA_P19_N17	VDP_LINE_01C[7:4]	114	0x72
VBI_DATA_P20_N18	VDP_LINE_01D[7:4]	115	0x73
VBI_DATA_P21_N19	VDP_LINE_01E[7:4]	116	0x74
VBI_DATA_P22_N20	VDP_LINE_01F[7:4]	117	0x75
VBI_DATA_P23_N21	VDP_LINE_020[7:4]	118	0x76
VBI_DATA_P24_N22	VDP_LINE_021[7:4]	119	0x77
VBI_DATA_P318	VDP_LINEe_00E[3:0]	100	0x64
VBI_DATA_P319_N286	VDP_LINE_00F[3:0]	101	0x65
VBI_DATA_P320_N287	VDP_LINE_010[3:0]	102	0x66
VBI_DATA_P321_N288	VDP_LINE_011[3:0]	103	0x67
VBI_DATA_P322	VDP_LINE_012[3:0]	104	0x68
VBI_DATA_P323	VDP_LINE_013[3:0]	105	0x69
VBI_DATA_P324_N272	VDP_LINE_014[3:0]	106	0x6A
VBI_DATA_P325_N273	VDP_LINE_015[3:0]	107	0x6B
VBI_DATA_P326_N274	VDP_LINE_016[3:0]	108	0x6C
VBI_DATA_P327_N275	VDP_LINE_017[3:0]	109	0x6D
VBI_DATA_P328_N276	VDP_LINE_018[3:0]	110	0x6E
VBI_DATA_P329_N277	VDP_LINE_019[3:0]	111	0x6F
VBI_DATA_P330_N278	VDP_LINE_01A[3:0]	112	0x70
VBI_DATA_P331_N279	VDP_LINE_01B[3:0]	113	0x71
VBI_DATA_P332_N280	VDP_LINE_01C[3:0]	114	0x72
VBI_DATA_P333_N281	VDP_LINE_01D[3:0]	115	0x73
VBI_DATA_P334_N282	VDP_LINE_01E[3:0]	116	0x74
VBI_DATA_P335_N283	VDP_LINE_01F[3:0]	117	0x75
VBI_DATA_P336_N284	VDP_LINE_020[3:0]	118	0x76
VBI_DATA_P337_N285	VDP_LINE_021[3:0]	119	0x77

**Note:**

**Full field detection** (lines other than VBI lines) of any standard can also be enabled by writing into the registers VBI\_DATA\_P24\_N22[3:0] and VBI\_DATA\_P337\_N285[3:0]. So, if VBI\_DATA\_P24\_N22[3:0] is programmed with any teletext standard, then teletext is decoded off the whole of the ODD field. The corresponding register for the EVEN field is VBI\_DATA\_P337\_N285[3:0].

**Teletext system identification:** VDP assumes that if teletext is present in a video channel, all the teletext lines comply with a single standard system. Thus, the line programming using VBI\_DATA\_Px\_Ny registers identifies whether the data in line is teletext; the actual standard is identified by the VDP\_TTXT\_TYPE\_MAN bit.

To program the VDP\_TTXT\_TYPE\_MAN bit, the VDP\_TTXT\_TYPE\_MAN\_ENABLE bit must be set to 1.

**VDP\_TTXT\_TYPE\_MAN\_ENABLE Enable Manual Selection of Teletext Type, Address 0x60 [2], User Sub Map**

0 (default)—Manual programming of the teletext type is disabled.

1—Manual programming of the teletext type is enabled.

**VDP\_TTXT\_TYPE\_MAN [1:0] Specify the Teletext Type, Address 0x60 [1:0], User Sub Map**

These bits specify the teletext type to be decoded. These bits are functional only if VDP\_TTXT\_TYPE\_MAN\_ENABLE is set to 1.

**Table 67. VDP\_TTXT\_TYPE\_MAN Function**

VDP_TTXT_TYPE_MAN [1:0]	Description	
00 (default)	625/50 (PAL) Teletext-ITU-BT.653-625/50-A.	525/60 (NTSC). Reserved.
01	Teletext-ITU-BT.653-625/50-B (WST).	Teletext-ITU-BT.653-525/60-B.
10	Teletext-ITU-BT.653-625/50-C.	Teletext-ITU-BT.653-525/60-C or EIA516 (NABTS).
11	Teletext-ITU-BT.653-625/50-D.	Teletext-ITU-BT.653-525/60-D.

**VDP Ancillary Data Output**

Reading the data back via I<sup>2</sup>C may not be feasible for VBI data standards with high data rates (for example, teletext). An alternative is to place the sliced data in a packet in the line blanking of the digital output CCIR656 stream. This is available for all standards sliced by the VDP module.

When data has been sliced on a given line, the corresponding ancillary data packet is placed immediately after the next EAV code that occurs at the output (that is, data sliced from multiple lines are not buffered up and then emitted in a burst). Note that the line number on which the packet is placed differs from the line number on which the data was sliced due to the vertical delay through the comb filters.

Users can enable or disable the insertion of VDP decoded results into the 656 ancillary streams by using the ADF\_ENABLE bit.

**ADF\_ENABLE Enable Ancillary Data Output Through 656 Stream, Address 0x62 [7], User Sub Map**

0 (default)—Disables insertion of VBI decoded data into ancillary 656 stream.

1—Enables insertion of VBI decoded data into ancillary 656 stream.

The user may select the data identification word (DID) and the secondary data identification word (SDID) through programming the ADF\_DID[4:0] and ADF\_SDID[5:0] bits respectively as explained next.

**ADF\_DID[4:0] User Specified Data ID Word in Ancillary Data, Address 0x62 [4:0], User Sub Map**

This bit selects the data ID word to be inserted in the ancillary data stream with the data decoded by the VDP.

The default value of ADF\_DID [4:0] is 10101.

**ADF\_SDID[5:0] User Specified Secondary Data ID Word in Ancillary Data, Address 0x63 [5:0], User Sub Map**

These bits select the secondary data ID word to be inserted in the ancillary data stream with the data decoded by the VDP.

The default value of ADF\_SDID [5:0] is 101010.

**DUPLICATE\_ADF Enable Duplication/Spreading of Ancillary Data over Y and C Buses, Address 0x 63 [7], User Sub Map**

This bit determines whether the ancillary data is duplicated over both Y and C buses or if the data packets are spread between the two channels.

0 (default)—The ancillary data packet is spread across the Y and C data streams.

1—The ancillary data packet is duplicated on the Y and C data streams.

**ADF\_MODE [1:0] Determine the Ancillary Data Output Mode, Address 0x62 [6:5], User Sub Map**

These bits determine if the ancillary data output mode is in byte mode or nibble mode.

**Table 68.**

ADF_MODE [1:0]	Description
00 (default)	Nibble mode.
01	Byte mode, no code restrictions.
10	Byte mode but 0x00 and 0xFF prevented (0x00 replaced by 0x01, 0xFF replaced by 0xFE).
11	Reserved.

# ADV7184

The ancillary data packet sequence is explained in Table 69 and Table 70. The nibble output mode is the default mode of output from the ancillary stream when ancillary stream output is enabled. This format is in compliance with ITU-R BT.1364.

Some definitions of the abbreviations used in Table 69 and Table 70 include:

- **EP.** Even parity for bits B8 to B2. This means that the parity bit EP is set so that an even number of 1s are in bits in B8 to B2, including the parity bit, D8.
- **CS.** Checksum word. The CS word is used to increase confidence of the integrity of the ancillary data packet from the DID, SDID, and DC through user data-words (UDWs). It consists of 10 bits: a 9-bit calculated value and B9 as the inverse of B8. The checksum value B8 to B0 is equal to the 9 LSBs of the sum of the 9 LSBs of the DID, SDID, and DC and all UDWs in the packet. Prior to the start of the checksum count cycle all checksum and carry bits are pre-set to zero. Any carry resulting from the checksum count cycle is ignored.

- **$\overline{\text{EP}}$ .** The MSB B9 is the inverse EP. This ensures that restricted codes 0x00 and 0xFF do not occur.
- **Line\_number [9:0].** The line number of the line that immediately precedes the ancillary data packet. The line number is as per the numbering system in ITU-R BT.470. The line number runs from 1 to 625 in a 625 line system and from 1 to 263 in a 525 line system. Note the line number on which the packet is output differs from the line number on which the VBI data was sliced due to the vertical delay through the comb filters.
- **Data Count.** The data count specifies the number of UDWs in the ancillary stream for the standard. The total number of user data-words =  $4 \times$  Data Count. Padding words may be introduced to make the total number of UDWs divisible by four.

**Table 69. Ancillary Data in Nibble Output Format**

Byte	B9	B8	B7	B6	B5	B4	B3	B2	B1	B0	Description	
0	0	0	0	0	0	0	0	0	0	0	Ancillary data preamble	
1	1	1	1	1	1	1	1	1	1	1		
2	1	1	1	1	1	1	1	1	1	1		
3	$\overline{\text{EP}}$	EP	0	I2C_DID6_2[4:0]					0	0	DID (data identification word)	
4	$\overline{\text{EP}}$	EP	I2C_SDID7_2[5:0]					0	0	SDID (secondary data identification word)		
5	$\overline{\text{EP}}$	EP	0	DC[4:0]				0	0	Data count		
6	$\overline{\text{EP}}$	EP	padding[1:0]	VBI_DATA_STD[3:0]				0	0	ID0 (user data-word 1)		
7	$\overline{\text{EP}}$	EP	0	Line_number[9:5]				0	0	ID1 (user data-word 2)		
8	$\overline{\text{EP}}$	EP	Even_Field	Line_number[4:0]				0	0	ID2 (user data-word 3)		
9	$\overline{\text{EP}}$	EP	0	0	0	0	VDP_TTXT_TYPE[1:0]	0	0	ID3 (user data-word 4)		
10	$\overline{\text{EP}}$	EP	0	0	VBI_WORD_1[7:4]				0	0	User data-word 5	
11	$\overline{\text{EP}}$	EP	0	0	VBI_WORD_1[3:0]				0	0	User data-word 6	
12	$\overline{\text{EP}}$	EP	0	0	VBI_WORD_2[7:4]				0	0	User data-word 7	
13	$\overline{\text{EP}}$	EP	0	0	VBI_WORD_2[3:0]				0	0	User data-word 8	
14	$\overline{\text{EP}}$	EP	0	0	VBI_WORD_3[7:4]				0	0	User data-word 9	
.	.	.	.	.	.	.	.	.	.	.	[Pad 0x200. These padding words may or may not be present depending on ancillary data type.] User data-word XX	
.	.	.	.	.	.	.	.	.	.	.		
.	.	.	.	.	.	.	.	.	.	.		
n-3	1	0	0	0	0	0	0	0	0	0		
n-2	1	0	0	0	0	0	0	0	0	0	User data-word XX	
n-1	B8	Checksum								0	0	CS (checksum word)

**Table 70. Ancillary Data in Byte Output Format<sup>1</sup>**

Byte	B9	B8	B7	B6	B5	B4	B3	B2	B1	B0	Description	
0	0	0	0	0	0	0	0	0	0	0	Ancillary data preamble	
1	1	1	1	1	1	1	1	1	1	1		
2	1	1	1	1	1	1	1	1	1	1		
3	$\overline{\text{EP}}$	EP	0	I2C_DID6_2[4:0]				0	0	DID		
4	$\overline{\text{EP}}$	EP	I2C_SDID7_2[5:0]				0	0	SDID			
5	$\overline{\text{EP}}$	EP	0	DC[4:0]				0	0	Data count		
6	$\overline{\text{EP}}$	EP	padding[1:0]		VBI_DATA_STD[3:0]			0	0	ID0 (user data-word 1)		
7	$\overline{\text{EP}}$	EP	0	Line_number[9:5]				0	0	ID1 (user data-word 2)		
8	$\overline{\text{EP}}$	EP	Even_Field	Line_number[4:0]			0	0	ID2 (user data-word 3)			
9	$\overline{\text{EP}}$	EP	0	0	0	0	VDP_TTXT_TYPE[1:0]	0	0	ID3 (user data-word 4)		
10	VBI_WORD_1[7:0]							0	0	User data-word 5		
11	VBI_WORD_2[7:0]							0	0	User data-word 6		
12	VBI_WORD_3[7:0]							0	0	User data-word 7		
13	VBI_WORD_4[7:0]							0	0	User data-word 8		
14	VBI_WORD_5[7:0]							0	0	User data-word 9		
.	.	.	.	.	.	.	.	.	.	.	[Pad 0x200. These padding words may or may not be present depending on ancillary data type.] User data-word XX	
.	.	.	.	.	.	.	.	.	.	.		
.	.	.	.	.	.	.	.	.	.	.		
n-3	1	0	0	0	0	0	0	0	0	0		
n-2	1	0	0	0	0	0	0	0	0	0		
n-1	$\overline{\text{B8}}$	Checksum							0	0		

<sup>1</sup> This mode does not fully comply with ITU-R BT.1364.

**Structure of VBI Words in Ancillary Data Stream**

Each VBI data standard has been split into a clock-run-in (CRI), a framing code (FC) and a number of data bytes (n). The data packet in the ancillary stream includes only the FC and data bytes. The VBI\_WORD\_X in the ancillary data stream has the following format.

**Table 71. Structure of VBI Data-Words in Ancillary Stream**

Ancillary data byte number	Byte Type	Byte Description
VBI_WORD_1	FC0	Framing code [23:16].
VBI_WORD_2	FC1	Framing Code [15:8].
VBI_WORD_3	FC2	Framing Code [7:0].
VBI_WORD_4	DB1	1 <sup>st</sup> data byte.
...	...	...
VBI_WORD_N+3	DBn	Last (nth) data byte.

**VDP Framing Code**

The length of the actual framing code depends on the VBI data standard. For uniformity, the length of the framing code reported in the ancillary data stream is always 24 bits. For standards with a lesser framing code length, the extra LSB bits are set to 0. The valid length of the framing code can be decoded from the VBI\_DATA\_STD bit available in ID0 (UDW 1). The framing code is always reported in the inverse-transmission order. Table 72 shows the framing code and its valid length for VBI data standards supported by VDP.

**Example**

For teletext (B-WST) the framing code byte is 11100100 (0xE4), bits shown in the order of transmission. Thus, VBI\_WORD\_1 = 0x27, VBI\_WORD\_2 = 0x00 and VBI\_WORD\_3 = 0x00. Translating them into UDWs in the ancillary data stream, for the nibble mode:

- UDW5 [5:2] = 0010
- UDW6 [5:2] = 0111
- UDW7 [5:2] = 0000 (undefined bits made zeros)
- UDW8 [5:2] = 0000 (undefined bits made zeros)
- UDW9 [5:2] = 0000 (undefined bits made zeros)
- UDW10 [5:2] = 0000 (undefined bits made zeros)

and for the byte mode:

- UDW5 [9:2] = 0010\_0111
- UDW6 [9:2] = 0000\_0000 (undefined bits made zeros)
- UDW7 [9:2] = 0000\_0000 (undefined bits made zeros)

# ADV7184

## Data Bytes

The VBI\_WORD\_4 to VBI\_WORD\_N+3 contains the data-words that were decoded by the VDP in the transmission order. The position of bits in bytes is in the inverse transmission order.

The number of VBI\_WORDS for each VBI data standard and the total number of UDWs in the ancillary data stream is shown in Table 73.

For example, closed caption has two user data bytes as shown in Table 77. The data bytes in the ancillary data stream would be:

VBI\_WORD\_4 = Byte1 [7:0]

VBI\_WORD\_5 = Byte2 [7:0]

**Table 72. Framing Code Sequence for Different VBI Standards**

VBI Standard	Length in Bits	Error Free Framing Code Bits (In Order of Transmission)	Error Free Framing Code Reported by VDP (In Reverse Order of Transmission)
TTXT_SYSTEM_A (PAL)	8	11100111	11100111
TTXT_SYSTEM_B (PAL)	8	11100100	00100111
TTXT_SYSTEM_B (NTSC)	8	11100100	00100111
TTXT_SYSTEM_C (PAL and NTSC)	8	11100111	11100111
TTXT_SYSTEM_D (PAL and NTSC)	8	11100101	10100111
VPS (PAL)	16	10001010100011001	1001100101010001
VITC (NTSC and PAL)	1	0	0
WSS (PAL)	24	000111100011110000011111	111110000011110001111000
GEMSTAR_1X (NTSC)	3	001	100
GEMSTAR_2X (NTSC)	11	1001_1011_101	101_1101_1001
CCAP (NTSC and PAL)	3	001	100
CGMS (NTSC)	1	0	0

**Table 73. Total User Data-Words for Different VBI Standards<sup>1</sup>**

VBI Standard	ADF Mode	Framing_code UDWs	VBI Data Words	Number of Padding Words	Total UDWs
TTXT_SYSTEM_A (PAL)	00 (Nibble Mode)	6	74	0	84
	01,10 (Byte Mode)	3	37	0	44
TTXT_SYSTEM_B (PAL)	00 (Nibble Mode)	6	84	2	96
	01,10 (Byte Mode)	3	42	3	52
TTXT_SYSTEM_B (NTSC)	00 (Nibble Mode)	6	68	2	80
	01,10 (Byte Mode)	3	34	3	44
TTXT_SYSTEM_C (PAL and NTSC)	00 (Nibble Mode)	6	66	0	76
	01,10 (Byte Mode)	3	33	2	42
TTXT_SYSTEM_D (PAL and NTSC)	00 (Nibble Mode)	6	68	2	80
	01,10 (Byte Mode)	3	34	3	44
VPS (PAL)	00 (Nibble Mode)	6	26	0	36
	01,10 (Byte Mode)	3	13	0	20
VITC (NTSC and PAL)	00 (Nibble Mode)	6	18	0	28
	01,10 (Byte Mode)	3	9	0	16
WSS (PAL)	00 (Nibble Mode)	6	4	2	16
	01,10 (Byte Mode)	3	2	3	12
GEMSTAR_1X (NTSC)	00 (Nibble Mode)	6	4	2	16
	01,10 (Byte Mode)	3	2	3	12
GEMSTAR_2X (NTSC)	00 (Nibble Mode)	6	8	2	20
	01,10 (Byte Mode)	3	4	1	12
CCAP (NTSC and PAL)	00 (Nibble Mode)	6	4	2	16
	01,10 (Byte Mode)	3	2	3	12
CGMS (NTSC)	00 (Nibble Mode)	6	6	0	16
	01,10 (Byte Mode)	3	3 + 3	2	12

<sup>1</sup> The first four UDWs are always the ID.

## I<sup>2</sup>C Interface

Dedicated I<sup>2</sup>C readback registers are available for CCAP, CGMS, WSS, Gemstar, VPS, PDC/UTC and VITC. Because teletext is a high data rate standard, data extraction is supported only through the ancillary data packet. The details of these registers and their access procedure are described next.

### User Interface for I<sup>2</sup>C Readback Registers

The VDP decodes all enabled VBI data standards in real time. Since the I<sup>2</sup>C access speed is much lower than the decoded rate, when the registers are being accessed they may be updated with data from the next line. In order to avoid this, VDP has a self-clearing CLEAR bit and an AVAILABLE status bit accompanying all the I<sup>2</sup>C readback registers.

The user has to clear the I<sup>2</sup>C readback register by writing a high to the CLEAR bit. This resets the state of the AVAILABLE bit to low and indicates that the data in the associated readback registers is not valid. After the VDP decodes the next line of the corresponding VBI data, the decoded data is placed in the I<sup>2</sup>C readback register and the AVAILABLE bit is set to HIGH to indicate that valid data is now available.

Though the VDP decodes this VBI data in subsequent lines if present, the decoded data is not updated to the readback registers until the CLEAR bit is set high again. However, this data is available through the 656 ancillary data packets.

The CLEAR and AVAILABLE bits are in the VDP\_CLEAR (0x78, User Sub Map, write only) and VDP\_STATUS (0x78, User Sub Map, read only) registers.

### Example I<sup>2</sup>C Readback Procedure

The following tasks have to be performed to read one packet (line) of PDC data from the decoder.

1. Write 10 to I2C\_GS\_VPS\_PDC\_UTC[1:0] (0x9C, User Sub Map) to specify that PDC data has to be updated to I<sup>2</sup>C registers.
2. Write high to the GS\_PDC\_VPS\_UTC\_CLEAR bit (0x78, User Sub Map) to enable I<sup>2</sup>C register updating.
3. Poll the GS\_PDC\_VPS\_UTC\_AVL bit (0x78, User Sub Map) going high to check the availability of the PDC packets.
4. Read the data bytes from the PDC I<sup>2</sup>C registers. To read another line or packet of data the above steps have to be repeated.

To read a packet of CC, CGMS, or WSS data, steps 1 through 3 only are required since they have dedicated registers.

## VDP—Content-Based Data Update

For certain standards like WSS, CGMS, Gemstar, PDC, UTC, and VPS the information content in the signal transmitted remains the same over numerous lines and the user may want to be notified only when there is a change in the information content or loss of the information content. The user must enable content-based updating for the required standard through the GS\_VPS\_PDC\_UTC\_CB\_CHANGE and WSS\_CGMS\_CB\_CHANGE bits. Thus the AVAILABLE bit shows the availability of that standard only when its content changes.

Content-based updating also applies to loss of data at the lines where some data was present before. Thus, for standards like VPS, Gemstar, CGMS, and WSS, if no data arrives in the next four lines programmed, the corresponding AVAILABLE bit in the VDP\_STATUS register is set high and the content in the I<sup>2</sup>C registers for that standard is set to zero. The user has to write high to the corresponding CLEAR bit so that when a valid line is decoded after some time, the decoded results are available into the I<sup>2</sup>C registers, with the AVAILABLE status bit set high.

If content-based updating is enabled, the AVAILABLE bit is set high (assuming the CLEAR bit was written) in the following cases:

- The data contents change.
- Data was being decoded and four lines with no data have been detected.
- No data was being decoded and new data is now being decoded.

### GS\_VPS\_PDC\_UTC\_CB\_CHANGE Enable Content-Based Updating for Gemstar/VPS/PDC/UTC, Address 0x9C [5], User Sub Map

0—Disables content-based updating.

1 (default)—Enables content-based updating.

### WSS\_CGMS\_CB\_CHANGE Enable Content-Based Updating for WSS/CGMS, Address 0x9C [4], User Sub Map

0—Disables content-based updating.

1 (default)—Enables content-based updating.

## VDP—Interrupt-Based Reading of VDP I<sup>2</sup>C registers

Some VDP status bits are also linked to the interrupt request controller so that the user does not have to poll the AVAILABLE status bit. The user can configure the video decoder to trigger an interrupt request on the INTRQ pin in response to the valid data available in I<sup>2</sup>C registers. This function is available for the following data types:

**CGMS or WSS:** The user can select between triggering an interrupt request each time sliced data is available or triggering an interrupt request only when the sliced data has changed. Selection is made via the WSS\_CGMS\_CB\_CHANGE bit.

# ADV7184

**Gemstar, PDC, VPS, or UTC:** The user can select between triggering an interrupt request each time sliced data is available or triggering an interrupt request only when the sliced data has changed. Selection is made via the GS\_VPS\_PDC\_UTC\_CB\_CHANGE bit.

The sequence for the interrupt-based reading of the VDP I<sup>2</sup>C data registers is the following for the CCAP standard.

1. User unmask CCAP interrupt mask bit (0x50 Bit 0, User Sub Map = 1). CCAP data occurs on the incoming video. VDP slices CCAP data and places it in the VDP readback registers.
2. The VDP CCAP available bit goes high and the VDP module signals to the interrupt controller to stimulate an interrupt request (for CCAP in this case).
3. The user reads the interrupt status bits (User Sub Map) and sees that new CCAP data is available (0x4E Bit 0, User Sub Map = 1).
4. The user writes 1 to the CCAP interrupt clear bit (0x4F Bit 0, User Sub Map = 1) in the Interrupt I<sup>2</sup>C space (this is a self-clearing bit). This clears the interrupt on the INTRQ pin but does NOT have an effect in the VDP I<sup>2</sup>C area.
5. The user reads the CCAP data from the VDP I<sup>2</sup>C area.
6. The user writes to a bit, CC\_CLEAR in the VDP\_STATUS [0] register, (0x78 Bit 0, User Sub Map = 1) to signify the CCAP data has been read (=> the VDP CCAP can be updated at the next occurrence of CCAP).
7. Back to step 2.

## Interrupt Mask Register Details

The following bits set the interrupt mask on the signal from the VDP VBI data slicer.

### VDP\_CCAPD\_MSKB Address 0x50 [0], User Sub Map

0 (default)—Disables interrupt on VDP\_CCAPD\_Q signal.

1—Enables interrupt on VDP\_CCAPD\_Q signal.

### VDP\_CGMS\_WSS\_CHNGD\_MSKB Address 0x50 [2], User Sub Map

0 (default)—Disables interrupt on VDP\_CGMS\_WSS\_CHNGD\_Q signal.

1—Enables interrupt on VDP\_CGMS\_WSS\_CHNGD\_Q signal.

### VDP\_GS\_VPS\_PDC\_UTC\_CHNG\_MSKB Address 0x50 [4], User Sub Map

0 (default)—Disables interrupt on

VDP\_GS\_VPS\_PDC\_UTC\_CHNG\_Q signal.

1—Enables interrupt on VDP\_GS\_VPS\_PDC\_UTC\_CHNG\_Q signal.

### VDP\_VITC\_MSKB Address 0x50 [6], User Sub Map

0 (default)—Disables interrupt on VDP\_VITC\_Q signal.

1—Enables interrupt on VDP\_VITC\_Q signal.

## Interrupt Status Register Details

The following read-only bits contain data detection information from the VDP module from the time the status bit has been last cleared or unmasked.

### VDP\_CCAPD\_Q Address 0x4E [0], User Sub Map

0 (default)—CCAP data has not been detected.

1—CCAP data has been detected.

### VDP\_CGMS\_WSS\_CHNGD\_Q Address 0x4E [2], User Sub Map

0 (default)—CGMS or WSS data has not been detected.

1—CGM or WSS data has been detected.

### VDP\_GS\_VPS\_PDC\_UTC\_CHNG\_Q Address 0x4E [4], User Sub Map

0 (default)—Gemstar, PDC, UTC, or VPS data has not been detected.

1—Gemstar, PDC, UTC, or VPS data has been detected.

### VDP\_VITC\_Q Address 0x4E [6], User Sub Map, read only

0 (default)—VITC data has not been detected.

1—VITC data has been detected.

## Interrupt Status Clear Register Details

It is not necessary to write 0 to these write-only bits as they automatically reset when they are set (self-clearing).

### VDP\_CCAPD\_CLR Address 0x4F [0], User Sub Map

1—Clears VDP\_CCAP\_Q bit.

### VDP\_CGMS\_WSS\_CHNGD\_CLR Address 0x4F [2], User Sub Map

1—Clears VDP\_CGMS\_WSS\_CHNGD\_Q bit.

### VDP\_GS\_VPS\_PDC\_UTC\_CHNG\_CLR Address 0x4F [4], User Sub Map

1—Clears VDP\_GS\_VPS\_PDC\_UTC\_CHNG\_Q bit.

### VDP\_VITC\_CLR Address 0x4F [6], User Sub Map

1—Clears VDP\_VITC\_Q bit.

**I<sup>2</sup>C READBACK REGISTERS**

**Teletext**

Because teletext is a high data rate standard, the decoded bytes are available only as ancillary data. However, a TTX\_AVL bit has been provided in I<sup>2</sup>C so that the user can check whether or not the VDP has detected teletext. Note that the TTX\_AVL bit is a plain status bit and does not use the protocol identified in the I<sup>2</sup>C Interface section.

**TTXT\_AVL Teletext Detected Status bit, Address 0x78 [7], User Sub Map, Read Only**

0—Teletext was not detected.

1—Teletext was detected.

**WST Packet Decoding**

For WST ONLY, the VDP decodes the Magazine and Row address of WST teletext packets and further decodes the packet's 8x4 hamming coded words. This feature can be disabled using WST\_PKT\_DECOD\_DISABLE bit (Bit 3, register 0x60, User Sub Map). The feature is valid for WST only.

**WST\_PKT\_DECOD\_DISABLE Disable Hamming Decoding of Bytes in WST, Address 0x60 [3], User Sub Map**

0—Enables hamming decoding of WST packets

1 (default)—Disables hamming decoding of WST packets.

For hamming coded bytes, the dehammed nibbles are output along with some error information from the hamming decoder as follows.

- Input Hamming Coded byte: {D3, P3, D2, P2, D1, P1, D0, P0} (bits in decoded order)
- Output Dehammed byte: {E1, E0, 0, 0, D3', D2', D1', D0'} (Di' – corrected bits, Ei error info).

**Table 74. Explanation of Error Bits in the Dehammed Output Byte**

E[1:0]	Error Information	Output Data Bits in Nibble
00	No errors detected	OK
01	Error in P4	OK
10	Double error	BAD
11	Single error found and corrected	OK

Table 75 describes the different WST packets that are decoded.

**Table 75. WST Packet Description**

Packet	Byte	Description
Header Packet (X/00)	1 <sup>st</sup> Byte 2 <sup>nd</sup> Byte 3 <sup>rd</sup> Byte 4 <sup>th</sup> Byte 5 <sup>th</sup> to 10 <sup>th</sup> Byte 11 <sup>th</sup> to 42 <sup>nd</sup> Byte	Mag No. – Dehammed Byte 4. Row No. – Dehammed Byte 5. Page No. – Dehammed Byte 6. Page No. – Dehammed Byte 7. Control Bytes – Dehammed Byte 8 to Byte 13. Raw data bytes.
Text Packets (X/01 to X/25)	1 <sup>st</sup> Byte 2 <sup>nd</sup> Byte 3 <sup>rd</sup> to 42 <sup>nd</sup> Byte	Mag No. – Dehammed Byte 4. Row No. – Dehammed Byte 5. Raw data bytes.
8/30 (Format 1) packet Desig Code = 0000 or 0001 UTC	1 <sup>st</sup> Byte 2 <sup>nd</sup> Byte 3 <sup>rd</sup> Byte 4 <sup>th</sup> Byte to 10 <sup>th</sup> Byte 11 <sup>th</sup> to 23 <sup>rd</sup> Byte 24 <sup>th</sup> to 42 <sup>nd</sup> Byte	Mag No. – Dehammed Byte 4. Row No. – Dehammed Byte 5. Desig Code. – Dehammed Byte 6. Dehammed Initial Teletext Page Byte 7 to Byte 12. UTC bytes – Dehammed Bytes 13 to Byte 25. Raw status bytes.
8/30 (Format 2) packet Desig Code = 0010 or 0011 PDC	1 <sup>st</sup> Byte 2 <sup>nd</sup> Byte 3 <sup>rd</sup> Byte 4 <sup>th</sup> Byte to 10 <sup>th</sup> Byte 11 <sup>th</sup> to 23 <sup>rd</sup> Byte 24 <sup>th</sup> to 42 <sup>nd</sup> Byte	Mag No. – Dehammed Byte 4. Row No. – Dehammed Byte 5. Desig Code. – Dehammed Byte 6. Dehammed Initial Teletext Page Byte 7 to Byte 12. PDC bytes – Dehammed Byte 13 to Byte 25. Raw status bytes.
X/26, X/27, X/28, X/29, X/30, X/31 <sup>1</sup>	1 <sup>st</sup> Byte 2 <sup>nd</sup> Byte 3 <sup>rd</sup> Byte 4 <sup>th</sup> to 42 <sup>nd</sup> Byte	Mag No. – Dehammed Byte 4. Row No. – Dehammed Byte 5. Desig Code. – Dehammed Byte 6. Raw data bytes.

<sup>1</sup> For X/26, X/28 and M/29, further decoding needs 24x18 hamming decoding. Not supported at present.

# ADV7184

## CGMS and WSS

The CGMS and WSS data packets convey the same type of information for different video standards. WSS is for PAL and CGMS is for NTSC and hence the CGMS and WSS readback registers are shared. WSS is bi-phase coded; the VDP does a biphasic decoding to produce the 14 raw WSS bits in the CGMS/WSS readback I<sup>2</sup>C registers and sets the CGMS\_WSS\_AVL bit.

### CGMS\_WSS\_CLEAR CGMS/WSS Clear, Address 0x78 [2], User Sub Map, Write Only, Self Clearing

1—Re-initializes the CGMS/WSS readback registers.

### CGMS\_WSS\_AVL CGMS/WSS Available Bit, Address 0x78 [2], User Sub Map, Read Only

0—CGMS/WSS was not detected.

1—CGMS/WSS was detected.

### CGMS\_WSS\_DATA\_0[3:0] Address 0x7D [3:0]

### CGMS\_WSS\_DATA\_1[7:0] Address 0x7E [7:0]

### CGMS\_WSS\_DATA\_2[7:0] Address 0x7F [7:0]

User Sub Map, read only. These bits hold the decoded CGMS or WSS data.

Refer to Figure 37 and Figure 38 for the I<sup>2</sup>C to WSS and CGMS bit mapping.

## CCAP

Two bytes of decoded closed caption data are available in the I<sup>2</sup>C registers. The field information of the decoded CCAP data can be obtained from the CC\_EVEN\_FIELD bit (register 0x78).

### CC\_CLEAR Closed Caption Clear, Address 0x78 [0] User Sub Map, Write Only, Self Clearing

1—Re-initializes the CCAP readback registers.

### CC\_AVL Closed Caption Available, Address 0x78 [0], User Sub Map, Read Only

0—Closed captioning was not detected.

1—Closed captioning was detected.

### CC\_EVEN\_FIELD Address 0x78 [1], User Sub Map, Read Only

Identifies the field from which the CCAP data was decoded.

0—Closed captioning detected on an ODD field.

1—Closed captioning was detected on an EVEN field.

### VDP\_CCAP\_DATA\_0 Address 0x79 [7:0], User Sub Map, Read Only

Decoded Byte 1 of CCAP data.

### VDP\_CCAP\_DATA\_1 Address 0x7A [7:0], User Sub Map, Read Only

Decoded Byte 2 of CCAP data.

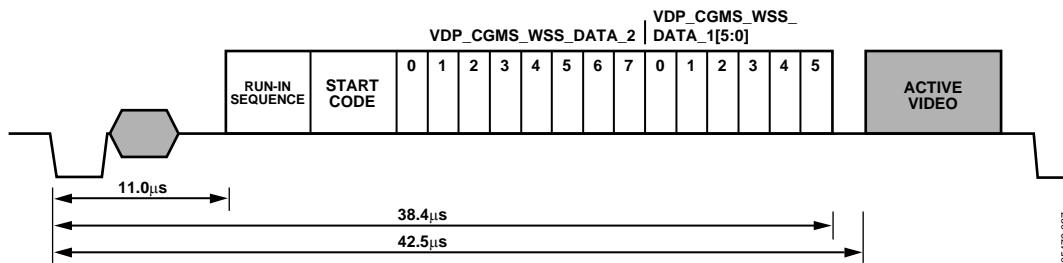

Figure 37. WSS Waveform

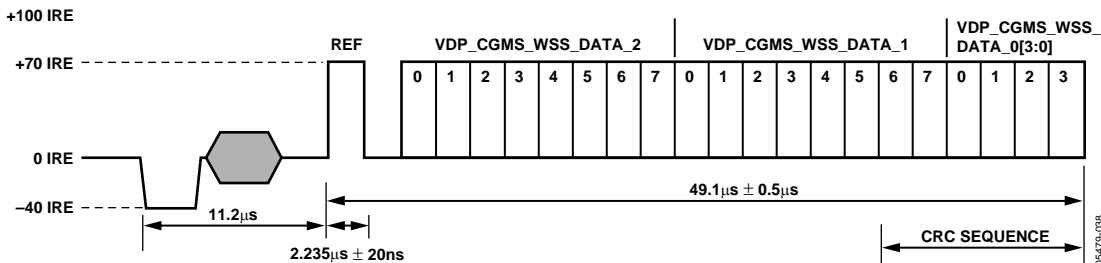

Figure 38. CGMS Waveform

Table 76. CGMS Readback Registers<sup>1</sup>

Signal Name	Register Location	Address (User Sub Map)	
CGMS_WSS_DATA_0[3:0]	VDP_CGMS_WSS_DATA_0 [3:0]	125	0x7D
CGMS_WSS_DATA_1[7:0]	VDP_CGMS_WSS_DATA_1 [7:0]	126	0x7E
CGMS_WSS_DATA_2[7:0]	VDP_CGMS_WSS_DATA_2 [7:0]	127	0x7F

<sup>1</sup> The register is a readback register; default value does not apply.

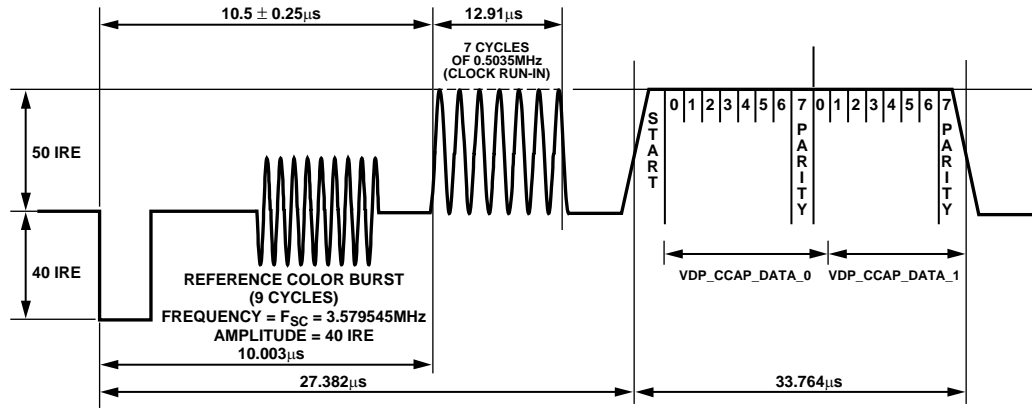

Figure 39. CCAP Waveform and Decoded Data Correlation

Table 77. CCAP Readback Registers<sup>1</sup>

Signal Name	Register Location	Address (User Sub Map)	
CCAP_BYTE_1[7:0]	VDP_CCAP_DATA_0[7:0]	121	0x79
CCAP_BYTE_2[7:0]	VDP_CCAP_DATA_1[7:0]	122	0x7A

<sup>1</sup> The register is a readback register; default value does not apply.

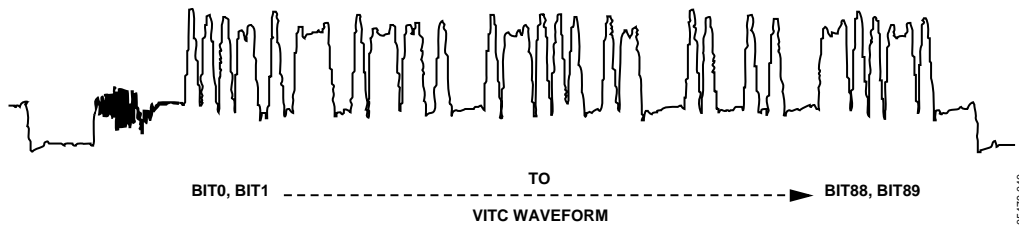

Figure 40. VITC Waveform and Decoded Data Correlation

### VITC

VITC has a sync sequence of 10 in between each data byte. The VDP strips these syncs from the data stream to give out only the data bytes. The VITC results are available in VDP\_VITC\_DATA\_0 to VDP\_VITC\_DATA\_8 registers (Register 0x92 to Register 0x9A, User Sub Map).

The VITC has a CRC byte at the end; the in-between syncs are also used in this CRC calculation. Since the in-between syncs are not given out, the CRC is also calculated internally. The calculated CRC is also available for the user in VITC\_CALC\_CRC register (Register 0x9B, User Sub Map). Once the VDP completes decoding the VITC line, the VITC\_DATA and VITC\_CALC\_CRC registers are updated and VITC\_AVL bit is set.

**VITC\_CLEAR** VITC Clear, Address 0x78 [6], User Sub Map, Write Only, Self Clearing

1—Re-initializes the VITC readback registers.

**VITC\_AVL** VITC Available, Address 0x78 [6], User Sub Map

0—VITC data was not detected.

1—VITC data was detected.

### VITC Readback Registers

See Figure 40 for the I<sup>2</sup>C to VITC bit mapping.

# ADV7184

**Table 78. VITC Readback Registers<sup>1</sup>**

Signal Name	Register Location	Address (User Sub Map)
VITC_DATA_0[7:0]	VDP_VITC_DATA_0[7:0] (VITC bits [9:2])	146 0x92
VITC_DATA_1[7:0]	VDP_VITC_DATA_1[7:0] (VITC bits [19:12])	147 0x93
VITC_DATA_2[7:0]	VDP_VITC_DATA_2[7:0] (VITC bits [29:22])	148 0x94
VITC_DATA_3[7:0]	VDP_VITC_DATA_3[7:0] (VITC bits [39:32])	149 0x95
VITC_DATA_4[7:0]	VDP_VITC_DATA_4[7:0] (VITC bits [49:42])	150 0x96
VITC_DATA_5[7:0]	VDP_VITC_DATA_5[7:0] (VITC bits [59:52])	151 0x97
VITC_DATA_6[7:0]	VDP_VITC_DATA_6[7:0] (VITC bits [69:62])	152 0x98
VITC_DATA_7[7:0]	VDP_VITC_DATA_7[7:0] (VITC bits [79:72])	153 0x99
VITC_DATA_8[7:0]	VDP_VITC_DATA_8[7:0] (VITC bits [89:82])	154 0x9A
VITC_CALC_CRC[7:0]	VDP_VITC_CALC_CRC[7:0]	155 0x9B

<sup>1</sup> The register is a readback register; default value does not apply.

## VPS/PDC/UTC/GEMSTAR

The readback registers for VPS, PDC and UTC have been shared. Gemstar is a high data rate standard and so is available only through the ancillary stream; however, for evaluation purposes any one line of Gemstar is available through I<sup>2</sup>C registers sharing the same register space as PDC, UTC, and VPS. Thus only one standard out of VPS, PDC, UTC, and Gemstar can be read through the I<sup>2</sup>C at a time.

The user has to program I2C\_GS\_VPS\_PDC\_UTC[1:0] (register address 0x9C, User Sub Map) to identify the data that should be made available in the I<sup>2</sup>C registers.

### I2C\_GS\_VPS\_PDC\_UTC (VDP) [1:0] Address 0x9C [6:5], User Sub Map

Specifies which standard result to be available for I<sup>2</sup>C readback.

**Table 79. I2C\_GS\_VPS\_PDC\_UTC[1:0] Function**

I2C_GS_VPS_PDC_UTC[1:0]	Description
00 (default)	Gemstar 1x/2x.
01	VPS.
10	PDC.
11	UTC.

### GS\_PDC\_VPS\_UTC\_CLEAR GS/PDC/VPS/UTC Clear, Address 0x78 [4], User Sub Map, Write Only, Self Clearing

1—Re-initializes the GS/PDC/VPS/UTC data readback registers.

### GS\_PDC\_VPS\_UTC\_AVL GS/PDC/VPS/UTC Available, Address 0x78 [4], User Sub Map, Read Only

0—One of GS, PDC, VPS or UTC data was not detected.

1—One of GS, PDC, VPS, or UTC data was detected.

### VDP\_GS\_VPS\_PDC\_UTC Readback Registers

See Table 80.

## VPS

The VPS data bits are bi-phase decoded by the VDP. The decoded data is available in both the ancillary stream and in the I<sup>2</sup>C readback registers. VPS decoded data is available in the VDP\_GS\_VPS\_PDC\_UTC\_0 to VDP\_VPS\_PDC\_UTC\_12 registers (addresses 0x84 – 0x90, User Sub Map). The GS\_VPS\_PDC\_UTC\_AVL bit is set if the user had programmed I2C\_GS\_VPS\_PDC\_UTC to 01, as explained in Table 79.

## GEMSTAR

The Gemstar decoded data is made available in the ancillary stream and any one line of Gemstar is also available in I<sup>2</sup>C registers for evaluation purposes. In order to obtain Gemstar results in I<sup>2</sup>C registers, the user has to program I2C\_GS\_VPS\_PDC\_UTC to 00, as explained in Table 79.

VDP supports auto detection of Gemstar standard between Gemstar 1× or Gemstar 2× and decodes accordingly. For this auto detection mode to work the user has to set AUTO\_DETECT\_GS\_TYPE I<sup>2</sup>C bit (register 0x61, User Sub Map) and program the decoder to decode Gemstar 2× on the required lines through line programming. The type of Gemstar decoded can be determined by observing the bit GS\_DATA\_TYPE bit (Register 0x78, User Sub Map).

### AUTO\_DETECT\_GS\_TYPE, Address 0x61 [4], User Sub Map

0 (default)—Disables autodetection of Gemstar type.

1—Enables autodetection.

### GS\_DATA\_TYPE, Address 0x78 [5], User Sub Map, Read Only

Identifies the decoded Gemstar data type.

0—Gemstar 1× mode is detected. Read 2 data bytes from 0x84.

1—Gemstar 2× mode is detected. Read 4 data bytes from 0x84.

The Gemstar data that is available in the I<sup>2</sup>C register could be from any line of the input video on which Gemstar was decoded. To read the Gemstar data on a particular video line, the user should use the Manual Configuration as described in Table 65 and Table 66 and enable Gemstar decoding on the required line only.

**Table 80. GS /VPS/PDC/UTC Readback Registers<sup>1</sup>**

Signal Name	Register Location	Address (User Sub Map)	
		Dec	Hex
GS_VPS_PDC_UTC_BYTE_0[7:0]	VDP_GS_VPS_PDC_UTC_0[7:0]	132d	0x84
GS_VPS_PDC_UTC_BYTE_1[7:0]	VDP_GS_VPS_PDC_UTC_1[7:0]	133d	0x85
GS_VPS_PDC_UTC_BYTE_2[7:0]	VDP_GS_VPS_PDC_UTC_2[7:0]	134d	0x86
GS_VPS_PDC_UTC_BYTE_3[7:0]	VDP_GS_VPS_PDC_UTC_3[7:0]	135d	0x87
VPS_PDC_UTC_BYTE_4[7:0]	VDP_VPS_PDC_UTC_4[7:0]	136d	0x88
VPS_PDC_UTC_BYTE_5[7:0]	VDP_VPS_PDC_UTC_5[7:0]	137d	0x89
VPS_PDC_UTC_BYTE_6[7:0]	VDP_VPS_PDC_UTC_6[7:0]	138d	0x8A
VPS_PDC_UTC_BYTE_7[7:0]	VDP_VPS_PDC_UTC_7[7:0]	139d	0x8B
VPS_PDC_UTC_BYTE_8[7:0]	VDP_VPS_PDC_UTC_8[7:0]	140d	0x8C
VPS_PDC_UTC_BYTE_9[7:0]	VDP_VPS_PDC_UTC_9[7:0]	141d	0x8D
VPS_PDC_UTC_BYTE_10[7:0]	VDP_VPS_PDC_UTC_10[7:0]	142d	0x8E
VPS_PDC_UTC_BYTE_11[7:0]	VDP_VPS_PDC_UTC_11[7:0]	143d	0x8F
VPS_PDC_UTC_BYTE_12[7:0]	VDP_VPS_PDC_UTC_12[7:0]	144d	0x90

<sup>1</sup> The register is a readback register; default value does not apply.

### PDC/UTC

PDC and UTC are data transmitted through teletext packet 8/30 format 2 (magazine 8, row 30, design\_code 2 or 3), and packet 8/30 format 1 (magazine 8, row 30, design\_code 0 or 1). Hence, if PDC or UTC data is to be read through I<sup>2</sup>C, the corresponding teletext standard (WST or PAL System B) should be decoded by VDP. The whole teletext decoded packet is output on the ancillary data stream. The user can look for the magazine number, row number and design\_code and qualify the data as PDC, UTC or none of these.

If PDC/UTC packets have been identified, Byte 0 to Byte 12 are updated to the GS\_VPS\_PDC\_UTC\_0 to VPS\_PDC\_UTC\_12 registers, and the GS\_VPS\_PDC\_UTC\_AVL bit set. The full packet data is also available in the ancillary data format.

Note that the data available in the I<sup>2</sup>C register depends on the status of the WST\_PKT\_DECODE\_DISABLE bit (Bit 3, subaddress 0x60, User Sub Map).

### VBI System 2

The user has an option of using a different VBI data slicer called VBI System 2. This data slicer is used to decode Gemstar and Closed Caption VBI signals only.

Using this system, the Gemstar data is only available in the ancillary data stream. A special mode enables one line of data to be read back via I<sup>2</sup>C. For details on how to get I<sup>2</sup>C readback when using the VBI System 2 data slicer, see the ADI applications note on ADV7184 VBI processing.

### Gemstar Data Recovery

The Gemstar-compatible data recovery block (GSCD) supports 1× and 2× data transmissions. In addition, it can serve as a closed caption decoder. Gemstar-compatible data transmissions can occur only in NTSC. Closed caption data can be decoded in both PAL and NTSC.

The block is configured via I<sup>2</sup>C in the following ways:

- GDECEL[15:0] allows data recovery on selected video lines on even fields to be enabled and disabled.
- GDECOL[15:0] enables the data recovery on selected lines for odd fields.
- GDECAD configures the way in which data is embedded in the video data stream.

The recovered data is not available through I<sup>2</sup>C, but is inserted into the horizontal blanking period of an ITU-R BT656-compatible data stream. The data format is intended to comply with the recommendation by the International Telecommunications Union, ITU-R BT.1364. For more information, see the ITU website at [www.itu.ch](http://www.itu.ch). See Figure 41.

### GDE\_SEL\_OLD\_ADF, Address 0x4C [3], User Map

The ADV7184 has a new ancillary data output block that can be used by the VDP data slicer and the VBI System 2 data slicer. The new ancillary data formatter is used by setting GDE\_SEL\_OLD\_ADF = 0 (this is the default setting). If this bit is set low, refer to Table 69 and Table 70 for information about how the data is packaged in the ancillary data stream.

To use the old ancillary data formatter (to be backward-compatible with the ADV7183B), set GDE\_SEL\_OLD\_ADF = 1. The ancillary data format in this section refers to the ADV7183B-compatible ancillary data formatter.

0 (default)—Enables new ancillary data system (for use with VDP and VBI System 2).

1—Enables old ancillary data system (for use with VBI System 2 only; ADV7183B-compatible).

# ADV7184

The format of the data packet depends on the following criteria:

- Transmission is 1× or 2×.
- Data is output in 8-bit or 4-bit format (see the description of the GDECAD Gemstar Decode Ancillary Data Format, Address 0x4C [0] bit).
- Data is closed caption (CCAP) or Gemstar-compatible.

Data packets are output if the corresponding enable bit is set (see the GDECEL[15:0] and GDECOL[15:0] descriptions), and if the decoder detects the presence of data. This means that for video lines where no data has been decoded, no data packet is output even if the corresponding line enable bit is set.

Each data packet starts immediately after the EAV code of the preceding line. Figure 41 and Table 81 show the overall structure of the data packet.

Entries within the packet are as follows:

- Fixed preamble sequence of 0x00, 0xFF, 0xFF.
- Data identification word (DID). The value for the DID marking a Gemstar or CCAP data packet is 0x140 (10-bit value).
- Secondary data identification word (SDID), which contains information about the video line from which data was retrieved, whether the Gemstar transmission was of 1× or 2× format, and whether it was retrieved from an even or odd field.
- Data count byte, giving the number of user data-words that follow.
- User data section.
- Optional padding to ensure that the length of the user data-word section of a packet is a multiple of four bytes (requirement as set in ITU-R BT.1364).
- Checksum byte.

Table 81 lists the values within a generic data packet that is output by the ADV7184 in 8-bit format.

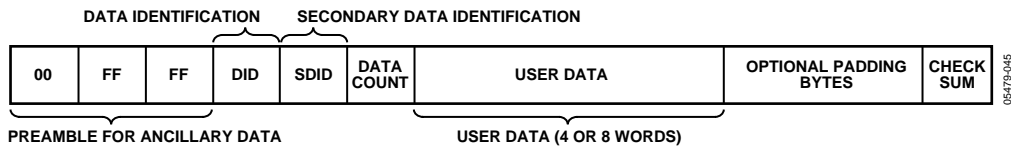

Figure 41. Gemstar and CCAP Embedded Data Packet (Generic)

Table 81. Generic Data Output Packet

Byte	D[9]	D[8]	D[7]	D[6]	D[5]	D[4]	D[3]	D[2]	D[1]	D[0]	Description
0	0	0	0	0	0	0	0	0	0	0	Fixed preamble
1	1	1	1	1	1	1	1	1	1	1	Fixed preamble
2	1	1	1	1	1	1	1	1	1	1	Fixed preamble
3	0	1	0	1	0	0	0	0	0	0	DID
4	EP	EP	EF	2X	line[3:0]			0	0	0	SDID
5	EP	EP	0	0	0	0	DC[1]	DC[0]	0	0	Data count (DC)
6	EP	EP	0	0	word1[7:4]			0	0	0	User data-words
7	EP	EP	0	0	word1[3:0]			0	0	0	User data-words
8	EP	EP	0	0	word2[7:4]			0	0	0	User data-words
9	EP	EP	0	0	word2[3:0]			0	0	0	User data-words
10	EP	EP	0	0	word3[7:4]			0	0	0	User data-words
11	EP	EP	0	0	word3[3:0]			0	0	0	User data-words
12	EP	EP	0	0	word4[7:4]			0	0	0	User data-words
13	EP	EP	0	0	word4[3:0]			0	0	0	User data-words
14	CS[8]	CS[8]	CS[7]	CS[6]	CS[5]	CS[4]	CS[3]	CS[2]	0	0	Checksum

Table 82. Data Byte Allocation

2x	Raw Information Bytes Retrieved from the Video Line	GDECAD	User Data-Words (Including Padding)	Padding Bytes	DC[1:0]
1	4	0	8	0	10
1	4	1	4	0	01
0	2	0	4	0	01
0	2	1	4	2	01

### Gemstar Bit Names

- DID. The data identification value is 0x140 (10-bit value). Care has been taken that in 8-bit systems, the two LSBs do not carry vital information.
- EP and  $\overline{\text{EP}}$ . The EP bit is set to ensure even parity on the data-word D[8:0]. Even parity means there is always an even number of 1s within the D[8:0] bit arrangement. This includes the EP bit.  $\overline{\text{EP}}$  describes the logic inverse of EP and is output on D[9]. The  $\overline{\text{EP}}$  is output to ensure that the reserved codes of 00 and FF cannot happen.
- EF. Even field identifier. EF = 1 indicates that the data was recovered from a video line on an even field.
- 2X. This bit indicates whether the data sliced was in Gemstar 1x or 2x format. A high indicates 2x format.
- line[3:0]. This entry provides a code that is unique for each of the possible 16 source lines of video from which Gemstar data may have been retrieved. Refer to Table 91 and Table 92.
- DC[1:0]. Data count value. The number of UDWs in the packet divided by 4. The number of UDWs in any packet must be an integral number of 4. Padding is required at the end, if necessary, as set in ITU-R BT.1364. See Table 82.
- The 2X bit determines whether the raw information retrieved from the video line was 2 or 4 bytes. The state of the GDECAD bit affects whether the bytes are transmitted straight (that is, two bytes transmitted as two bytes) or whether they are split into nibbles (that is, two bytes transmitted as four half bytes). Padding bytes are then added where necessary.
- CS[8:2]. The checksum is provided to determine the integrity of the ancillary data packet. It is calculated by summing up D[8:2] of DID, SDID, the data count byte, and all UDWs, and ignoring any overflow during the summation. Since all data bytes that are used to calculate the checksum have their 2 LSBs set to 0, the CS[1:0] bits are also always 0.  
 $\overline{\text{CS}}[8]$  describes the logic inversion of CS[8]. The value  $\overline{\text{CS}}[8]$  is included in the checksum entry of the data packet to ensure that the reserved values of 0x00 and 0xFF do not occur. Table 83 to Table 88 outline the possible data packages.

### Gemstar 2x Format, Half-Byte Output Mode

Half-byte output mode is selected by setting CDECAD = 0; full-byte output mode is selected by setting CDECAD = 1. See the GDECAD Gemstar Decode Ancillary Data Format, Address 0x4C [0] section.

### Gemstar 1x Format

Half-byte output mode is selected by setting CDECAD = 0, full-byte output mode is selected by setting CDECAD = 1. See the GDECAD Gemstar Decode Ancillary Data Format, Address 0x4C [0] section.

# ADV7184

**Table 83. Gemstar 2× Data, Half-Byte Mode**

Byte	D[9]	D[8]	D[7]	D[6]	D[5]	D[4]	D[3]	D[2]	D[1]	D[0]	Description
0	0	0	0	0	0	0	0	0	0	0	Fixed preamble
1	1	1	1	1	1	1	1	1	1	1	Fixed preamble
2	1	1	1	1	1	1	1	1	1	1	Fixed preamble
3	0	1	0	1	0	0	0	0	0	0	DID
4	$\overline{EP}$	EP	EF	1	line[3:0]				0	0	SDID
5	$\overline{EP}$	EP	0	0	0	0	1	0	0	0	Data count
6	$\overline{EP}$	EP	0	0	Gemstar word1[7:4]				0	0	User data-words
7	$\overline{EP}$	EP	0	0	Gemstar word1[3:0]				0	0	User data-words
8	$\overline{EP}$	EP	0	0	Gemstar word2[7:4]				0	0	User data-words
9	$\overline{EP}$	EP	0	0	Gemstar word2[3:0]				0	0	User data-words
10	$\overline{EP}$	EP	0	0	Gemstar word3[7:4]				0	0	User data-words
11	$\overline{EP}$	EP	0	0	Gemstar word3[3:0]				0	0	User data-words
12	$\overline{EP}$	EP	0	0	Gemstar word4[7:4]				0	0	User data-words
13	$\overline{EP}$	EP	0	0	Gemstar word4[3:0]				0	0	User data-words
14	$\overline{CS[8]}$	CS[8]	CS[7]	CS[6]	CS[5]	CS[4]	CS[3]	CS[2]	CS[1]	CS[0]	Checksum

**Table 84. Gemstar 2× Data, Full-Byte Mode**

Byte	D[9]	D[8]	D[7]	D[6]	D[5]	D[4]	D[3]	D[2]	D[1]	D[0]	Description
0	0	0	0	0	0	0	0	0	0	0	Fixed preamble
1	1	1	1	1	1	1	1	1	1	1	Fixed preamble
2	1	1	1	1	1	1	1	1	1	1	Fixed preamble
3	0	1	0	1	0	0	0	0	0	0	DID
4	$\overline{EP}$	EP	EF	1	line[3:0]				0	0	SDID
5	$\overline{EP}$	EP	0	0	0	0	0	1	0	0	Data count
6	Gemstar word1[7:0]								0	0	User data-words
7	Gemstar word2[7:0]								0	0	User data-words
8	Gemstar word3[7:0]								0	0	User data-words
9	Gemstar word4[7:0]								0	0	User data-words
10	$\overline{CS[8]}$	CS[8]	CS[7]	CS[6]	CS[5]	CS[4]	CS[3]	CS[2]	CS[1]	CS[0]	Checksum

**Table 85. Gemstar 1× Data, Half-Byte Mode**

Byte	D[9]	D[8]	D[7]	D[6]	D[5]	D[4]	D[3]	D[2]	D[1]	D[0]	Description
0	0	0	0	0	0	0	0	0	0	0	Fixed preamble
1	1	1	1	1	1	1	1	1	1	1	Fixed preamble
2	1	1	1	1	1	1	1	1	1	1	Fixed preamble
3	0	1	0	1	0	0	0	0	0	0	DID
4	$\overline{EP}$	EP	EF	0	line[3:0]				0	0	SDID
5	$\overline{EP}$	EP	0	0	0	0	0	1	0	0	Data count
6	$\overline{EP}$	EP	0	0	Gemstar word1[7:4]				0	0	User data-words
7	$\overline{EP}$	EP	0	0	Gemstar word1[3:0]				0	0	User data-words
8	$\overline{EP}$	EP	0	0	Gemstar word2[7:4]				0	0	User data-words
9	$\overline{EP}$	EP	0	0	Gemstar word2[3:0]				0	0	User data-words
10	$\overline{CS[8]}$	CS[8]	CS[7]	CS[6]	CS[5]	CS[4]	CS[3]	CS[2]	CS[1]	CS[0]	Checksum

Table 86. Gemstar 1× Data, Full-Byte Mode

Byte	D[9]	D[8]	D[7]	D[6]	D[5]	D[4]	D[3]	D[2]	D[1]	D[0]	Description
0	0	0	0	0	0	0	0	0	0	0	Fixed preamble
1	1	1	1	1	1	1	1	1	1	1	Fixed preamble
2	1	1	1	1	1	1	1	1	1	1	Fixed preamble
3	0	1	0	1	0	0	0	0	0	0	DID
4	$\overline{EP}$	EP	EF	0	line[3:0]				0	0	SDID
5	$\overline{EP}$	EP	0	0	0	0	0	1	0	0	Data count
6	Gemstar word1[7:0]								0	0	User data-words
7	Gemstar word2[7:0]								0	0	User data-words
8	1	0	0	0	0	0	0	0	0	0	UDW padding 0x200
9	1	0	0	0	0	0	0	0	0	0	UDW padding 0x200
10	$\overline{CS[8]}$	CS[8]	CS[7]	CS[6]	CS[5]	CS[4]	CS[3]	CS[2]	CS[1]	CS[0]	Checksum

Table 87. NTSC CCAP Data, Half-Byte Mode

Byte	D[9]	D[8]	D[7]	D[6]	D[5]	D[4]	D[3]	D[2]	D[1]	D[0]	Description
0	0	0	0	0	0	0	0	0	0	0	Fixed preamble
1	1	1	1	1	1	1	1	1	1	1	Fixed preamble
2	1	1	1	1	1	1	1	1	1	1	Fixed preamble
3	0	1	0	1	0	0	0	0	0	0	DID
4	$\overline{EP}$	EP	EF	0	1	0	1	1	0	0	SDID
5	$\overline{EP}$	EP	0	0	0	0	0	1	0	0	Data count
6	$\overline{EP}$	EP	0	0	CCAP word1[7:4]				0	0	User data-words
7	$\overline{EP}$	EP	0	0	CCAP word1[3:0]				0	0	User data-words
8	$\overline{EP}$	EP	0	0	CCAP word2[7:4]				0	0	User data-words
9	$\overline{EP}$	EP	0	0	CCAP word2[3:0]				0	0	User data-words
10	$\overline{CS[8]}$	CS[8]	CS[7]	CS[6]	CS[5]	CS[4]	CS[3]	CS[2]	CS[1]	CS[0]	Checksum

Table 88. NTSC CCAP Data, Full-Byte Mode

Byte	D[9]	D[8]	D[7]	D[6]	D[5]	D[4]	D[3]	D[2]	D[1]	D[0]	Description
0	0	0	0	0	0	0	0	0	0	0	Fixed preamble
1	1	1	1	1	1	1	1	1	1	1	Fixed preamble
2	1	1	1	1	1	1	1	1	1	1	Fixed preamble
3	0	1	0	1	0	0	0	0	0	0	DID
4	$\overline{EP}$	EP	EF	0	1	0	1	1	0	0	SDID
5	$\overline{EP}$	EP	0	0	0	0	0	1	0	0	Data count
6	CCAP word1[7:0]								0	0	User data-words
7	CCAP word2[7:0]								0	0	User data-words
8	1	0	0	0	0	0	0	0	0	0	UDW padding 0x200
9	1	0	0	0	0	0	0	0	0	0	UDW padding 0x200
10	$\overline{CS[8]}$	CS[8]	CS[7]	CS[6]	CS[5]	CS[4]	CS[3]	CS[2]	CS[1]	CS[0]	Checksum

# ADV7184

**Table 89. PAL CCAP Data, Half-Byte Mode**

Byte	D[9]	D[8]	D[7]	D[6]	D[5]	D[4]	D[3]	D[2]	D[1]	D[0]	Description
0	0	0	0	0	0	0	0	0	0	0	Fixed preamble
1	1	1	1	1	1	1	1	1	1	1	Fixed preamble
2	1	1	1	1	1	1	1	1	1	1	Fixed preamble
3	0	1	0	1	0	0	0	0	0	0	DID
4	$\overline{EP}$	EP	EF	0	1	0	1	0	0	0	SDID
5	$\overline{EP}$	EP	0	0	0	0	0	1	0	0	Data count
6	$\overline{EP}$	EP	0	0	CCAP word1[7:4]				0	0	User data-words
7	$\overline{EP}$	EP	0	0	CCAP word1[3:0]				0	0	User data-words
8	$\overline{EP}$	EP	0	0	CCAP word2[7:4]				0	0	User data-words
9	$\overline{EP}$	EP	0	0	CCAP word2[3:0]				0	0	User data-words
10	$\overline{CS[8]}$	CS[8]	CS[7]	CS[6]	CS[5]	CS[4]	CS[3]	CS[2]	CS[1]	CS[0]	Checksum

**Table 90. PAL CCAP Data, Full-Byte Mode**

Byte	D[9]	D[8]	D[7]	D[6]	D[5]	D[4]	D[3]	D[2]	D[1]	D[0]	Description
0	0	0	0	0	0	0	0	0	0	0	Fixed preamble
1	1	1	1	1	1	1	1	1	1	1	Fixed preamble
2	1	1	1	1	1	1	1	1	1	1	Fixed preamble
3	0	1	0	1	0	0	0	0	0	0	DID
4	$\overline{EP}$	EP	EF	0	1	0	1	0	0	0	SDID
5	$\overline{EP}$	EP	0	0	0	0	0	1	0	0	Data Count
6	CCAP word1[7:0]								0	0	User data-words
7	CCAP word2[7:0]								0	0	User data-words
8	1	0	0	0	0	0	0	0	0	0	UDW padding 200h
9	1	0	0	0	0	0	0	0	0	0	UDW padding 200h
10	$\overline{CS[8]}$	CS[8]	CS[7]	CS[6]	CS[5]	CS[4]	CS[3]	CS[2]	CS[1]	CS[0]	Checksum

## NTSC CCAP Data

Half-byte output mode is selected by setting CDECAD = 0, the full-byte mode is enabled by CDECAD = 1. See the GDECAD Gemstar Decode Ancillary Data Format, Address 0x4C [0] section. The data packet formats are shown in Table 87 and Table 88. Only closed caption data can be embedded in the output data stream.

NTSC closed caption data is sliced on Line 21d on even and odd fields. The corresponding enable bit has to be set high. See the GDECAD Gemstar Decode Ancillary Data Format, Address 0x4C [0] and GDECOL[15:0] Gemstar Decoding Odd Lines, Address 0x4A [7:0]; Address 0x4B [7:0] sections.

## PAL CCAP Data

Half-byte output mode is selected by setting CDECAD = 0, full-byte output mode is selected by setting CDECAD = 1. See the GDECAD Gemstar Decode Ancillary Data Format, Address 0x4C [0] section. Table 89 and Table 90 list the bytes of the data packet.

Only closed caption data can be embedded in the output data stream. PAL closed caption data is sliced from Line 22 and Line 335. The corresponding enable bits have to be set.

See the GDECEL[15:0] Gemstar Decoding Even Lines, Address 0x48 [7:0]; Address 0x49 [7:0] and GDECOL[15:0] Gemstar Decoding Odd Lines, Address 0x4A [7:0]; Address 0x4B [7:0] sections.

## GDECEL[15:0] Gemstar Decoding Even Lines, Address 0x48 [7:0]; Address 0x49 [7:0]

The 16 bits of the GDECEL[15:0] are interpreted as a collection of 16 individual line decode enable signals. Each bit refers to a line of video in an even field. Setting the bit enables the decoder block trying to find Gemstar or closed caption-compatible data on that particular line. Setting the bit to 0 prevents the decoder from trying to retrieve data. See Table 91 and Table 92.

To retrieve closed caption data services on NTSC (Line 284), GDECEL[11] must be set.

To retrieve closed caption data services on PAL (Line 335), GDECEL[14] must be set.

The default value of GDECEL[15:0] is 0x0000. This setting instructs the decoder not to attempt to decode Gemstar or CCAP data from any line in the even field. The user should only enable Gemstar slicing on lines where VBI data is expected.

**Table 91. NTSC Line Enable Bits and Corresponding Line Numbering**

Line[3:0]	Line Number (ITU-R BT.470)	Enable Bit	Comment
0	10	GDECOL[0]	Gemstar
1	11	GDECOL[1]	Gemstar
2	12	GDECOL[2]	Gemstar
3	13	GDECOL[3]	Gemstar
4	14	GDECOL[4]	Gemstar
5	15	GDECOL[5]	Gemstar
6	16	GDECOL[6]	Gemstar
7	17	GDECOL[7]	Gemstar
8	18	GDECOL[8]	Gemstar
9	19	GDECOL[9]	Gemstar
10	20	GDECOL[10]	Gemstar
11	21	GDECOL[11]	Gemstar or closed caption
12	22	GDECOL[12]	Gemstar
13	23	GDECOL[13]	Gemstar
14	24	GDECOL[14]	Gemstar
15	25	GDECOL[15]	Gemstar
0	273 (10)	GDECEL[0]	Gemstar
1	274 (11)	GDECEL[1]	Gemstar
2	275 (12)	GDECEL[2]	Gemstar
3	276 (13)	GDECEL[3]	Gemstar
4	277 (14)	GDECEL[4]	Gemstar
5	278 (15)	GDECEL[5]	Gemstar
6	279 (16)	GDECEL[6]	Gemstar
7	280 (17)	GDECEL[7]	Gemstar
8	281 (18)	GDECEL[8]	Gemstar
9	282 (19)	GDECEL[9]	Gemstar
10	283 (20)	GDECEL[10]	Gemstar
11	284 (21)	GDECEL[11]	Gemstar or closed caption
12	285 (22)	GDECEL[12]	Gemstar
13	286 (23)	GDECEL[13]	Gemstar
14	287 (24)	GDECEL[14]	Gemstar
15	288 (25)	GDECEL[15]	Gemstar

**GDECOL[15:0] Gemstar Decoding Odd Lines, Address 0x4A [7:0]; Address 0x4B [7:0]**

The 16 bits of the GDECOL[15:0] form a collection of 16 individual line decode enable signals. See Table 91 and Table 92.

To retrieve closed caption data services on NTSC (Line 21), GDECOL[11] must be set.

To retrieve closed caption data services on PAL (Line 22), GDECOL[14] must be set.

The default value of GDECOL[15:0] is 0x0000. This setting instructs the decoder not to attempt to decode Gemstar or CCAP data from any line in the odd field. The user should only enable Gemstar slicing on lines where VBI data is expected.

**GDECAD Gemstar Decode Ancillary Data Format, Address 0x4C [0]**

The decoded data from Gemstar-compatible transmissions or closed caption transmission is inserted into the horizontal blanking period of the respective line of video. A potential problem can arise if the retrieved data bytes have the value 0x00 or 0xFF. In an ITU-R BT.656-compatible data stream, those values are reserved and used only to form a fixed preamble.

The GDECAD bit allows the data to be inserted into the horizontal blanking period in two ways:

- Insert all data straight into the data stream, even the reserved values of 0x00 and 0xFF, if they occur. This may violate the output data format specification ITU-R BT.1364.
- Split all data into nibbles and insert the half-bytes over double the number of cycles in a 4-bit format.

0 (default)—The data is split into half-bytes and inserted.

1—The data is output straight in 8-bit format.

# ADV7184

**Table 92. PAL Line Enable Bits and Corresponding Line Numbering**

Line[3:0]	Line Number (ITU-R BT.470)	Enable Bit	Comment
12	8	GDECOL[0]	Not valid
13	9	GDECOL[1]	Not valid
14	10	GDECOL[2]	Not valid
15	11	GDECOL[3]	Not valid
0	12	GDECOL[4]	Not valid
1	13	GDECOL[5]	Not valid
2	14	GDECOL[6]	Not valid
3	15	GDECOL[7]	Not valid
4	16	GDECOL[8]	Not valid
5	17	GDECOL[9]	Not valid
6	18	GDECOL[10]	Not valid
7	19	GDECOL[11]	Not valid
8	20	GDECOL[12]	Not valid
9	21	GDECOL[13]	Not valid
<b>10</b>	<b>22</b>	<b>GDECOL[14]</b>	<b>Closed caption</b>
11	23	GDECOL[15]	Not valid
12	321 (8)	GDECEL[0]	Not valid
13	322 (9)	GDECEL[1]	Not valid
14	323 (10)	GDECEL[2]	Not valid
15	324 (11)	GDECEL[3]	Not valid
0	325 (12)	GDECEL[4]	Not valid
1	326 (13)	GDECEL[5]	Not valid
2	327 (14)	GDECEL[6]	Not valid
3	328 (15)	GDECEL[7]	Not valid
4	329 (16)	GDECEL[8]	Not valid
5	330 (17)	GDECEL[9]	Not valid
6	331 (18)	GDECEL[10]	Not valid
7	332 (19)	GDECEL[11]	Not valid
8	333 (20)	GDECEL[12]	Not valid
9	334 (21)	GDECEL[13]	Not valid
<b>10</b>	<b>335 (22)</b>	<b>GDECEL[14]</b>	<b>Closed caption</b>
11	336 (23)	GDECEL[15]	Not valid

## Letterbox Detection

Incoming video signals may conform to different aspect ratios (16:9 wide screen or 4:3 standard). For certain transmissions in the wide screen format, a digital sequence (WSS) is transmitted with the video signal. If a WSS sequence is provided, the aspect ratio of the video can be derived from the digitally decoded bits WSS contains.

In the absence of a WSS sequence, letterbox detection may be used to find wide screen signals. The detection algorithm examines the active video content of lines at the start and end of a field. If black lines are detected, this may indicate that the currently shown picture is in wide screen format.

The active video content (luminance magnitude) over a line of video is summed together. At the end of a line, this accumulated value is compared with a threshold and a decision is made as to whether or not a particular line is black. The threshold value needed may depend on the type of input signal; some control is provided via LB\_TH[4:0].

## Detection at the Start of a Field

The ADV7184 expects a section of at least six consecutive black lines of video at the top of a field. Once those lines are detected, register LB\_LCT[7:0] reports back the number of black lines that were actually found. By default, the ADV7184 starts looking for those black lines in sync with the beginning of active video, for example, straight after the last VBI video line. LB\_SL[3:0] allows the user to set the start of letterbox detection from the beginning of a frame on a line-by-line basis. The detection window closes in the middle of the field.

## Detection at the End of a Field

The ADV7184 expects at least six continuous lines of black video at the bottom of a field before reporting the number of lines actually found via the LB\_LCB[7:0] value. The activity window for letterbox detection (end of field) starts in the middle of an active field. Its end is programmable via LB\_EL[3:0].

## Detection at the Midrange

Some transmissions of wide screen video include subtitles within the lower black box. If the ADV7184 finds at least two black lines followed by some more nonblack video, for example, the subtitle, followed by the remainder of the bottom black block, it reports a midcount via LB\_LCM[7:0]. If no subtitles are found, LB\_LCM[7:0] reports the same number as LB\_LCB[7:0].

There is a 2-field delay in the reporting of any line count parameters.

There is no letterbox detected bit. Read the LB\_LCT[7:0] and LB\_LCB[7:0] register values to conclude whether or not the letterbox-type video is present in software.

**LB\_LCT[7:0] Letterbox Line Count Top, Address 0x9B [7:0];**  
**LB\_LCM[7:0] Letterbox Line Count Mid, Address 0x9C [7:0];**  
**LB\_LCB[7:0] Letterbox Line Count Bottom, Address 0x9D [7:0]**

**Table 93. LB\_LCx Access Information<sup>1</sup>**

Signal Name	Address
LB_LCT[7:0]	0x9B
LB_LCM[7:0]	0x9C
LB_LCB[7:0]	0x9D

<sup>1</sup> This register is a readback register; default value does not apply.

**LB\_TH[4:0] Letterbox Threshold Control, Address 0xDC [4:0]**

**Table 94. LB\_TH Function**

LB_TH[4:0]	Description
01100 (default)	Default threshold for detection of black lines.
01101 to 10000	Increase threshold (need larger active video content before identifying nonblack lines).
00000 to 01011	Decrease threshold (even small noise levels can cause the detection of nonblack lines).

**LB\_SL[3:0] Letterbox Start Line, Address 0xDD [7:4]**

The LB\_SL[3:0] bits are set at 0100 by default. For an NTSC signal, this window is from Line 23 to Line 286.

By changing the bits to 0101, the detection window starts on Line 24 and ends on Line 287.

**LB\_EL[3:0] Letterbox End Line, Address 0xDD [3:0]**

The LB\_EL[3:0] bits are set at 1101 by default. This means that letterbox detection window ends with the last active video line. For an NTSC signal, this window is from Line 262 to Line 525.

By changing the bits to 1100, the detection window starts on Line 261 and ends on Line 254.

**IF Compensation Filter**

**IFFILTSEL[2:0] IF Filter Select Address 0xF8 [2:0]**

The IFFILTSEL[2:0] register allows the user to compensate for SAW filter characteristics on a composite input as would be observed on tuner outputs. Figure 42 and Figure 43 show IF filter compensation for NTSC and PAL.

The options for this feature are as follows:

- Bypass mode (default)
- NTSC—consists of three filter characteristics
- PAL—consists of three filter characteristics

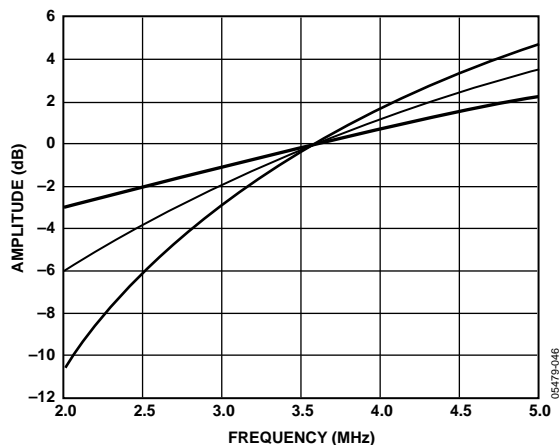

Figure 42. NTSC IF Compensation Filter Responses

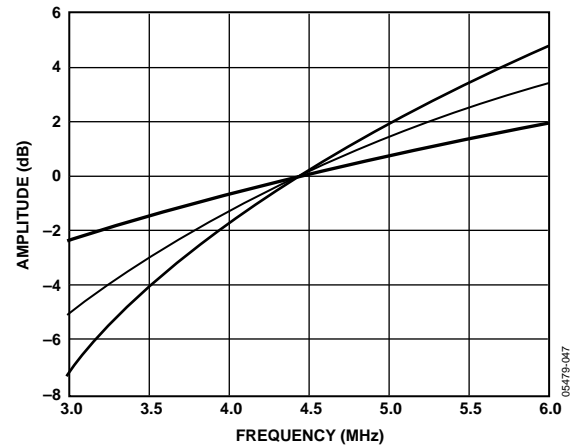

Figure 43. PAL IF Compensation Filter Responses

See Table 102 for programming details.

**I<sup>2</sup>C Interrupt System**

The ADV7184 has a comprehensive interrupt register set. This map is located in the User Sub Map. See Table 103 for details of the interrupt register map. Figure 46 describes how to access this map.

**Interrupt Request Output Operation**

When an interrupt event occurs, the interrupt pin  $\overline{\text{INTRQ}}$  goes low with a programmable duration given by INTRQ\_DUR\_SEL[1:0]

**INTRQ\_DURSEL[1:0], Interrupt Duration Select Address 0x40 [7:6], User Sub Map**

**Table 95. INTRQ\_DUR\_SEL**

INTRQ_DURSEL[1:0]	Description
00 (default)	3 XTAL periods.
01	15 XTAL periods.
10	63 XTAL periods.
11	Active until cleared.

When the active-until-cleared interrupt duration is selected, and the event that caused the interrupt is no longer in force, the interrupt persists until it is masked or cleared.

For example, if the ADV7184 loses lock, an interrupt is generated and the  $\overline{\text{INTRQ}}$  pin goes low. If the ADV7184 returns to the locked state,  $\overline{\text{INTRQ}}$  continues to drive low until the SD\_LOCK bit is either masked or cleared.

# ADV7184

## Interrupt Drive Level

The ADV7184 resets with open drain enabled and all interrupts masked off. Therefore  $\overline{\text{INTRQ}}$  is in a high impedance state after reset. 01 or 10 has to be written to  $\text{INTRQ\_OP\_SEL}[1:0]$  for a logic level to be driven out from the  $\overline{\text{INTRQ}}$  pin.

It is also possible to write to a register in the ADV7184 that manually asserts the  $\overline{\text{INTRQ}}$  pin. This bit is  $\text{MPU\_STIM\_INTRQ}$ .

### $\text{INTRQ\_OP\_SEL}[1:0]$ , Interrupt Duration Select Address 0x40 [1:0], User Sub Map

Table 96.  $\text{INTRQ\_OP\_SEL}$

$\text{INTRQ\_OP\_SEL}[1:0]$	Description
00 (default)	Open drain.
01	Drive low when active.
10	Drive high when active.
11	Reserved.

## Multiple Interrupt Events

If interrupt event 1 occurs and then interrupt event 2 occurs before the system controller has cleared or masked interrupt event 1, the ADV7184 does not generate a second interrupt signal. The system controller should check all unmasked interrupt status bits since more than one may be active.

## Macrovision Interrupt Selection Bits

The user can select between pseudo sync pulse and color stripe detection as follows:

### $\text{MV\_INTRQ\_SEL}[1:0]$ , Macrovision Interrupt Selection Bits Address 0x40 [5:4], User Sub Map

Table 97.  $\text{MV\_INTRQ\_SEL}$

$\text{MV\_INTRQ\_SEL}[1:0]$	Description
00	Reserved.
01 (default)	Pseudo sync only.
10	Color stripe only.
11	Either pseudo sync or color stripe.

Additional information relating to the interrupt system is detailed in Table 104.

## PIXEL PORT CONFIGURATION

The ADV7184 has a very flexible pixel port that can be configured in a variety of formats to accommodate downstream ICs. Table 98 and Table 99 summarize the various functions that the ADV7184’s pins can have in different modes of operation.

The ordering of components (Cr vs. Cb, CHA/B/C, for example) can be changed. Refer to the SWPC Swap Pixel Cr/Cb, Address 0x27 [7] section. Table 98 indicates the default positions for the Cr/Cb components.

### OF\_SEL[3:0] Output Format Selection, Address 0x03 [5:2]

The modes in which the ADV7184 pixel port can be configured are under the control of OF\_SEL[3:0]. See Table 99 for details.

The default LLC frequency output on the LLC1 pin is approximately 27 MHz. For modes that operate with a nominal data rate of 13.5 MHz (0001, 0010), the clock frequency on the LLC1 pin stays at the higher rate of 27 MHz. For information on outputting the nominal 13.5 MHz clock on the LLC1 pin, see the LLC\_PAD\_SEL[2:0] LLC1 Output Selection, Address 0x8F [6:4] section.

### SWPC Swap Pixel Cr/Cb, Address 0x27 [7]

0 (default)—No swapping is allowed.

1—The Cr and Cb values can be swapped.

### LLC\_PAD\_SEL[2:0] LLC1 Output Selection, Address 0x8F [6:4]

The following I<sup>2</sup>C write allows the user to select between LLC1 (nominally at 27 MHz) and LLC2 (nominally at 13.5 MHz).

The LLC2 signal is useful for LLC2-compatible wide bus (16-bit) output modes. See the OF\_SEL[3:0] Output Format Selection, Address 0x03 [5:2] section for additional information. The LLC2 signal and data on the data bus are synchronized. By default, the rising edge of LLC1/LLC2 is aligned with the Y data; the falling edge occurs when the data bus holds C data. The polarity of the clock, and therefore the Y/C assignments to the clock edges, can be altered by using the Polarity LLC pin.

000 (default)—The output is nominally 27 MHz LLC on the LLC1 pin.

101—The output is nominally 13.5 MHz LLC on the LLC1 pin.

**Table 98. P15–P0 Output/Input Pin Mapping**

Format, and Mode	Data Port Pins P[15:0]															
	15	14	13	12	11	10	9	8	7	6	5	4	3	2	1	0
Video Out, 8-Bit, 4:2:2	YCrCb[7:0]OUT															
Video Out, 16-Bit, 4:2:2	Y[7:0]OUT								CrCb[7:0] OUT							

**Table 99. Standard Definition Pixel Port Modes**

OF_SEL[3:0]	Format	Pixel Port Pins P[15:0]	
		P[15:8]	P[7:0]
0010	16-Bit at LLC2 4:2:2	Y[7:0]	CrCb[7:0]
0011 (default)	8-Bit at LLC1 4:2:2 (default)	YCrCb[7:0] (default)	Three-State
0110-1111	Reserved	Reserved. Do not use.	

## MPU PORT DESCRIPTION

The ADV7184 supports a 2-wire (I<sup>2</sup>C-compatible) serial interface. Two inputs, serial data (SDA) and serial clock (SCLK), carry information between the ADV7184 and the system I<sup>2</sup>C master controller. Each slave device is recognized by a unique address. The ADV7184's I<sup>2</sup>C port allows the user to set up and configure the decoder and to read back captured VBI data. The ADV7184 has two possible slave addresses for both read and write operations, depending on the logic level on the ALSB pin. These four unique addresses are shown in Table 100. The ALSB pin controls Bit 1 of the slave address. By altering the ALSB, it is possible to control two ADV7184s in an application without having a conflict with the same slave address. The LSB (Bit 0) sets either a read or write operation. Logic 1 corresponds to a read operation; Logic 0 corresponds to a write operation.

**Table 100. I<sup>2</sup>C Address**

ALSB	R/W	Slave Address
0	0	0x40
0	1	0x41
1	0	0x42
1	1	0x43

To control the device on the bus, a specific protocol must be followed. First, the master initiates a data transfer by establishing a start condition, which is defined by a high-to-low transition on SDA while SCLK remains high. This indicates that an address/data stream follows. All peripherals respond to the start condition and shift the next eight bits (7-bit address + R/W bit). The bits are transferred from MSB down to LSB. The peripheral that recognizes the transmitted address responds by pulling the data line low during the ninth clock pulse; this is known as an acknowledge bit. All other devices withdraw from the bus at this point and maintain an idle condition. The idle condition is where the device monitors the SDA and SCLK lines, waiting for the start condition and the correct transmitted address. The R/W bit determines the direction of the data. Logic 0 on the LSB of the first byte means the master writes information to the peripheral. Logic 1 on the LSB of the first byte means the master reads information from the peripheral.

The ADV7184 acts as a standard slave device on the bus. The data on the SDA pin is eight bits long, supporting the 7-bit addresses plus the R/W bit. The ADV7184 has 249 subaddresses to enable access to the internal registers. It therefore interprets the first byte as the device address and the second byte as the starting subaddress. The subaddresses auto-increment, allowing data to be written to or read from the starting subaddress. A data transfer is always terminated by a stop condition. The user can also access any unique subaddress register on a one-by-one basis without updating all the registers.

Stop and start conditions can be detected at any stage during the data transfer. If these conditions are asserted out of sequence with normal read and write operations, they cause an immediate jump to the idle condition. During a given SCLK high period, the user should issue only one start condition, one stop condition, or a single stop condition followed by a single start condition. If an invalid subaddress is issued by the user, the ADV7184 does not issue an acknowledge and returns to the idle condition.

If in autoincrement mode the highest subaddress is exceeded, the following action is taken:

1. In read mode, the highest subaddress register contents continue to be output until the master device issues a no acknowledge. This indicates the end of a read. In a no acknowledge condition the SDA line is not pulled low on the ninth pulse.
2. In write mode, the data for the invalid byte is not loaded into any subaddress register, a no acknowledge is issued by the ADV7184, and the part returns to the idle condition.

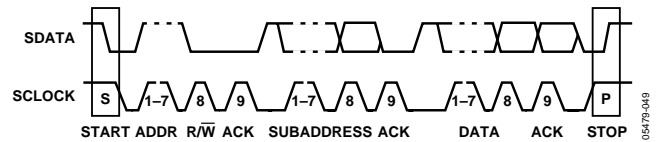

Figure 44. Bus Data Transfer

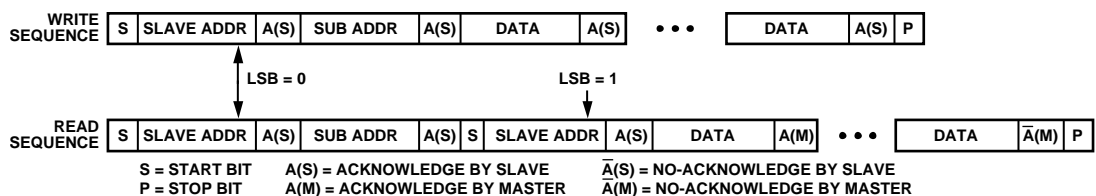

Figure 45. Read and Write Sequence

## REGISTER ACCESSES

The MPU can write to or read from most of the ADV7184's registers, excepting the registers that are read only or write only. The subaddress register determines which register the next read or write operation accesses. All communications with the part through the bus start with an access to the subaddress register. A read/write operation is then performed from/to the target address, which then increments to the next address until a stop command on the bus is performed.

## REGISTER PROGRAMMING

The I<sup>2</sup>C Register Maps section describes each register in terms of its configuration. After the part has been accessed over the bus and a read/write operation is selected, the subaddress is set up. The subaddress register determines to/from which register the operation takes place. Table 103 and Table 104 list the various operations under the control of the subaddress register.

As can be seen in Figure 46, the registers in the ADV7184 are arranged into two maps: the User Map (enabled by default) and the User Sub Map. The User Sub Map has controls for the interrupt and VDP functionality on the ADV7184 and the User Map controls everything else.

The User Map and the User Sub Map consist of a common space from address 0x00 to 0x3F. Depending on how Bit 5 in register 0x0E (SUB\_USR\_EN) is set, the register map then splits in two sections.

### SUB\_USR\_EN, Address 0x0E [5]

This bit splits the register map at register 0x40.

0 (default)—The register map does not split and the User Map is enabled.

1—The register map splits and the User Sub Map is enabled.

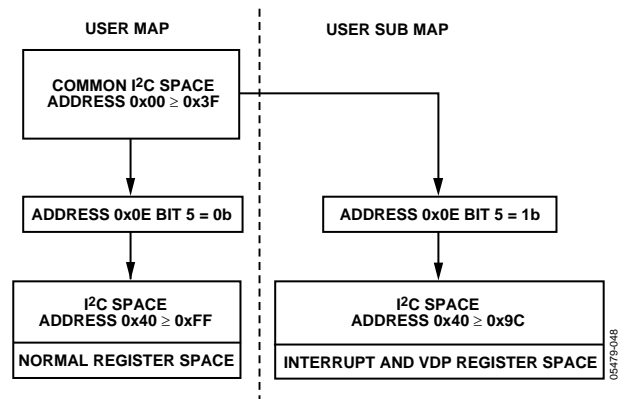

Figure 46: Register Access — User Map and User Sub Map

## I<sup>2</sup>C SEQUENCER

An I<sup>2</sup>C sequencer is used when a parameter exceeds eight bits, and is therefore distributed over two or more I<sup>2</sup>C registers, for example, HSB [11:0].

When such a parameter is changed using two or more I<sup>2</sup>C write operations, the parameter may hold an invalid value for the time between the first and last I<sup>2</sup>C being completed. In other words, the top bits of the parameter may already hold the new value while the remaining bits of the parameter still hold the previous value.

To avoid this problem, the I<sup>2</sup>C sequencer holds the already updated bits of the parameter in local memory; all bits of the parameter are updated together once the last register write operation has completed.

The correct operation of the I<sup>2</sup>C sequencer relies on the following:

- All I<sup>2</sup>C registers for the parameter in question must be written to in order of ascending addresses. For example, for HSB[10:0], write to Address 0x34 first, followed by 0x35.
- No other I<sup>2</sup>C taking place between the two (or more) I<sup>2</sup>C writes for the sequence. For example, for HSB[10:0], write to Address 0x34 first, immediately followed by 0x35.

# ADV7184

## I<sup>2</sup>C REGISTER MAPS

### USER MAP

The collective name for the registers in Table 101 below is the User Map.

**Table 101. User Map Register Details**

Address	Dec	Hex	Register Name	RW	7	6	5	4	3	2	1	0	Reset Value	(Hex)
0	00		Input Ctrl	RW	VID_SEL.3	VID_SEL.2	VID_SEL.1	VID_SEL.0	INSEL.3	INSEL.2	INSEL.1	INSEL.0	00000000	00
1	01		Video Selection	RW		ENHSPLL	BETACAM		ENVSPROC				11001000	C8
3	03		Output Ctrl	RW	VBI_EN	TOD	OF_SEL.3	OF_SEL.2	OF_SEL.1	OF_SEL.0		SD_DUP_AV	00001100	0C
4	04		Ext Output Ctrl	RW	BT656-4				TIM_OE	BL_C_VBI	EN_SFL_PIN	RANGE	01xx0101	45
7	07		Autodetect Enable	RW	AD_SECS25_EN	AD_SECAM_EN	AD_N443_EN	AD_P60_EN	AD_PALN_EN	AD_PALM_EN	AD_NTSC_EN	AD_PAL_EN	01111111	7F
8	08		Contrast	RW	CON.7	CON.6	CON.5	CON.4	CON.3	CON.2	CON.1	CON.0	10000000	80
10	0A		Brightness	RW	BRI.7	BRI.6	BRI.5	BRI.4	BRI.3	BRI.2	BRI.1	BRI.0	00000000	00
11	0B		Hue	RW	HUE.7	HUE.6	HUE.5	HUE.4	HUE.3	HUE.2	HUE.1	HUE.0	00000000	00
12	0C		Default Value Y	RW	DEF_Y.5	DEF_Y.4	DEF_Y.3	DEF_Y.2	DEF_Y.1	DEF_Y.0	DEF_VAL_AUTO_EN	DEF_VAL_EN	00110110	36
13	0D		Default Value C	RW	DEF_C.7	DEF_C.6	DEF_C.5	DEF_C.4	DEF_C.3	DEF_C.2	DEF_C.1	DEF_C.0	01111100	7C
14	0E		ADI Ctrl				SUB_USR_EN						00000000	00
15	0F		Power Mgmt	RW	RES		PWRDN			PDBP	FB_PWRDN		00000000	00
16	10		Status 1	R	COL_KILL	AD_RESULT.2	AD_RESULT.1	AD_RESULT.0	FOLLOW_PW	FSC_LOCK	LOST_LOCK	IN_LOCK	---	---
18	12		Status 2	R			FSC_NSTD	LL_NSTD	MV_AGC_DET	MV_PS_DET	MVCS_T3	MVCS_DET	---	---
19	13		Status 3	R	PAL_SW_LOCK	INTERLACE	STD_FLD_LEN	FREE_RUN_ACT	CVBS	SD_OP_50Hz	GEMD	INST_HLOCK	---	---
19	13		Analog Ctrl Internal	W						XTAL_TTL_SEL			00000000	00
20	14		Analog Clamp Ctrl	RW				CCLN					00010010	12
21	15		Digital Clamp Ctrl 1	RW		DCT.1	DCT.0						0000xxxx	00
23	17		Shaping Filter Ctrl	RW	CSFM.2	CSFM.1	CSFM.0	YSFM.4	YSFM.3	YSFM.2	YSFM.1	YSFM.0	00000001	01
24	18		Shaping Filter Ctrl 2	RW	WYSFMOVR			WYSFM.4	WYSFM.3	WYSFM.2	WYSFM.1	WYSFM.0	10010011	93
25	19		Comb Filter Ctrl	RW					NSFSEL.1	NSFSEL.0	PSFSEL.1	PSFSEL.0	11110001	F1
29	1D		ADI Ctrl 2	RW	TRI_LLC	EN28XTAL							00000xxx	00
39	27		Pixel Delay Ctrl	RW	SWPC	AUTO_PDC_EN	CTA.2	CTA.1	CTA.0		LTA.1	LTA.0	01011000	58
43	2B		Misc Gain Ctrl	RW		CKE						PW_UPD	11100001	E1
44	2C		AGC Mode Ctrl	RW		LAGC.2	LAGC.1	LAGC.0			CAGC.1	CAGC.0	10101110	AE
45	2D		Chroma Gain Ctrl 1	W	CAGT.1	CAGT.0			CMG.11	CMG.10	CMG.9	CMG.8	11110100	F4
46	2E		Chroma Gain Ctrl 2	W	CMG.7	CMG.6	CMG.5	CMG.4	CMG.3	CMG.2	CMG.1	CMG.0	00000000	00
47	2F		Luma Gain Ctrl 1	W	LGAT.1	LGAT.0			LMG.11	LMG.10	LMG.9	LMG.8	1111xxxx	F0
48	30		Luma Gain Ctrl 2	W	LMG.7	LMG.6	LMG.5	LMG.4	LMG.3	LMG.2	LMG.1	LMG.0	xxxxxxxx	00
49	31		VSYNC Field Ctrl 1	RW				NEWAVMODE	HVSTIM				00010010	12
50	32		VSYNC Field Ctrl 2	RW	VSBHO	VSBHE							01000001	41
51	33		VSYNC Field Ctrl 3	RW	VSEHO	VSEHE							10000100	84
52	34		HSYNC Pos Ctrl 1	RW		HSB.10	HSB.9	HSB.8		HSE.10	HSE.9	HSE.8	00000000	00
53	35		HSYNC Pos Ctrl 2	RW	HSB.7	HSB.6	HSB.5	HSB.4	HSB.3	HSB.2	HSB.1	HSB.0	00000010	02
54	36		HSYNC Pos Ctrl 3	RW	HSE.7	HSE.6	HSE.5	HSE.4	HSE.3	HSE.2	HSE.1	HSE.0	00000000	00
55	37		Polarity	RW	PHS		PVS		PF			PCLK	00000001	01
56	38		NTSC Comb Ctrl	RW	CTAPSN.1	CTAPSN.0	CCMN.2	CCMN.1	CCMN.0	YCMN.2	YCMN.1	YCMN.0	10000000	80
57	39		PAL Comb Ctrl	RW	CTAPSP.1	CTAPSP.0	CCMP.2	CCMP.1	CCMP.0	YCMP.2	YCMP.1	YCMP.0	11000000	C0
58	3A		ADC Ctrl	RW					PDN_ADC0	PDN_ADC1	PDN_ADC2	PDN_ADC3	00010001	11
61	3D		Man Window Ctrl	RW		CKILLTHR.2	CKILLTHR.1	CKILLTHR.0					01000011	43
65	41		Resample Ctrl	RW		SFL_INV							00000001	01
72	48		Gemstar Ctrl 1	RW	GDECEL.15	GDECEL.14	GDECEL.13	GDECEL.12	GDECEL.11	GDECEL.10	GDECEL.9	GDECEL.8	00000000	00
73	49		Gemstar Ctrl 2	RW	GDECEL.7	GDECEL.6	GDECEL.5	GDECEL.4	GDECEL.3	GDECEL.2	GDECEL.1	GDECEL.0	00000000	00
74	4A		Gemstar Ctrl 3	RW	GDECOL.15	GDECOL.14	GDECOL.13	GDECOL.12	GDECOL.11	GDECOL.10	GDECOL.9	GDECOL.8	00000000	00
75	4B		Gemstar Ctrl 4	RW	GDECOL.7	GDECOL.6	GDECOL.5	GDECOL.4	GDECOL.3	GDECOL.2	GDECOL.1	GDECOL.0	00000000	00
76	4C		Gemstar Ctrl 5	RW								GDECAD	xxxx0000	00
77	4D		CTI DNR Ctrl 1	RW			DNR_EN		CTI_AB.1	CTI_AB.0	CTI_AB_EN	CTI_EN	11101111	EF
78	4E		CTI DNR Ctrl 2	RW	CTI_C_TH.7	CTI_C_TH.6	CTI_C_TH.5	CTI_C_TH.4	CTI_C_TH.3	CTI_C_TH.2	CTI_C_TH.1	CTI_C_TH.0	00001000	08
80	50		CTI DNR Ctrl 4	RW	DNR_TH.7	DNR_TH.6	DNR_TH.5	DNR_TH.4	DNR_TH.3	DNR_TH.2	DNR_TH.1	DNR_TH.0	00001000	08
81	51		Lock Count	RW	FSCLE	SRLS	COL.2	COL.1	COL.0	CIL.2	CIL.1	CIL.0	00100100	24
143	8F		Free Run Line Length1	W		LLC_PAD_SEL_MAN	LLC_PAD_SEL.1	LLC_PAD_SEL.0					00000000	00
153	99		CCAP 1	R	CCAP1.7	CCAP1.6	CCAP1.5	CCAP1.4	CCAP1.3	CCAP1.2	CCAP1.1	CCAP1.0	---	---
154	9A		CCAP 2	R	CCAP2.7	CCAP2.6	CCAP2.5	CCAP2.4	CCAP2.3	CCAP2.2	CCAP2.1	CCAP2.0	---	---

Address		Register Name	RW	7	6	5	4	3	2	1	0	Reset Value	(Hex)
Dec	Hex												
155	9B	Letterbox 1	R	LB_LCT.7	LB_LCT.6	LB_LCT.5	LB_LCT.4	LB_LCT.3	LB_LCT.2	LB_LCT.1	LB_LCT.0	---	---
156	9C	Letterbox 2	R	LB_LCM.7	LB_LCM.6	LB_LCM.5	LB_LCM.4	LB_LCM.3	LB_LCM.2	LB_LCM.1	LB_LCM.0	---	---
157	9D	Letterbox 3	R	LB_LCB.7	LB_LCB.6	LB_LCB.5	LB_LCB.4	LB_LCB.3	LB_LCB.2	LB_LCB.1	LB_LCB.0	---	---
195	C3	ADC Switch 1	RW	ADC1_SW.3	ADC1_SW.2	ADC1_SW.1	ADC1_SW.0	ADC0_SW.3	ADC0_SW.2	ADC0_SW.1	ADC0_SW.0	xxxxxxxx	00
196	C4	ADC Switch 2	RW	ADC_SW_MAN				ADC2_SW.3	ADC2_SW.2	ADC2_SW.1	ADC2_SW.0	0xxxxxxx	00
220	DC	Letterbox Ctrl1	RW				LB_TH.4	LB_TH.3	LB_TH.2	LB_TH.1	LB_TH.0	10101100	AC
221	DD	Letterbox Ctrl2	RW	LB_SL.3	LB_SL.2	LB_SL.1	LB_SL.0	LB_EL.3	LB_EL.2	LB_EL.1	LB_EL.0	01001100	4C
222	DE	ST Noise Readback 1	R					ST_NOISE_VLD	ST_NOISE.10	ST_NOISE.9	ST_NOISE.8	---	---
223	DF	ST Noise Readback 2	R	ST_NOISE.7	ST_NOISE.6	ST_NOISE.5	ST_NOISE.4	ST_NOISE.3	ST_NOISE.2	ST_NOISE.1	ST_NOISE.0	---	---
225	E1	SD Offset Cb	RW	SD_OFF_CB.7	SD_OFF_CB.6	SD_OFF_CB.5	SD_OFF_CB.4	SD_OFF_CB.3	SD_OFF_CB.2	SD_OFF_CB.1	SD_OFF_CB.0	10000000	80
226	E2	SD Offset Cr	RW	SD_OFF_CR.7	SD_OFF_CR.6	SD_OFF_CR.5	SD_OFF_CR.4	SD_OFF_CR.3	SD_OFF_CR.2	SD_OFF_CR.1	SD_OFF_CR.0	10000000	80
227	E3	SD Saturation CB	RW	SD_SAT_CB.7	SD_SAT_CB.6	SD_SAT_CB.5	SD_SAT_CB.4	SD_SAT_CB.3	SD_SAT_CB.2	SD_SAT_CB.1	SD_SAT_CB.0	10000000	80
228	E4	SD Saturation Cr	RW	SD_SAT_CR.7	SD_SAT_CR.6	SD_SAT_CR.5	SD_SAT_CR.4	SD_SAT_CR.3	SD_SAT_CR.2	SD_SAT_CR.1	SD_SAT_CR.0	10000000	80
229	E5	NTSC V bit begin	RW	NVBEGDELO	NVBEGDELE	NVBEGSIGN	NVBEG.4	NVBEG.3	NVBEG.2	NVBEG.1	NVBEG.0	00100101	25
230	E6	NTSC V bit end	RW	NVENDDELO	NVENDDELE	NVENDSIGN	NVEND.4	NVEND.3	NVEND.2	NVEND.1	NVEND.0	00000100	04
231	E7	NTSC F bit toggle	RW	NFTOGDELO	NFTOGDELE	NFTOGSIGN	NFTOG.4	NFTOG.3	NFTOG.2	NFTOG.1	NFTOG.0	01100011	63
232	E8	PAL V bit begin	RW	PVBEGDELO	PVBEGDELE	PVBEGSIGN	PVBEG.4	PVBEG.3	PVBEG.2	PVBEG.1	PVBEG.0	01100101	65
233	E9	PAL V bit end	RW	PVENDDELO	PVENDDELE	PVENDSIGN	PVEND.4	PVEND.3	PVEND.2	PVEND.1	PVEND.0	00010100	14
234	EA	PAL F bit toggle	RW	PFTOGDELO	PFTOGDELE	PFTOGSIGN	PFTOG.4	PFTOG.3	PFTOG.2	PFTOG.1	PFTOG.0	01100011	63
235	EB	Vblank Ctrl 1	RW	NVBIOLCM.1	NVBIOLCM.0	NVBIELCM.1	NVBIELCM.0	PVBIOLCM.1	PVBIOLCM.0	PVBIELCM.1	PVBIELCM.0	01010101	55
236	EC	Vblank Ctrl2	RW	NVBIOCM.1	NVBIOCM.0	NVBIECM.1	NVBIECM.0	PVBIOCM.1	PVBIOCM.0	PVBIECM.1	PVBIECM.0	01010101	55
237	ED	FB_STATUS	R	FB_STATUS.3	FB_STATUS.2	FB_STATUS.1	FB_STATUS.0					---	---
237	ED	FB_CONTROL1	W					FB_INV	CVBS_RGB_SEL	FB_MODE.1	FB_MODE.0	00010000	10
238	EE	FB_CONTROL 2	RW	FB_CSC_MAN	MAN_ALPHA_VAL.6	MAN_ALPHA_VAL.5	MAN_ALPHA_VAL.4	MAN_ALPHA_VAL.3	MAN_ALPHA_VAL.2	MAN_ALPHA_VAL.1	MAN_ALPHA_VAL.0	00000000	00
239	EF	FB_CONTROL 3	RW	FB_SP_ADJUST.3	FB_SP_ADJUST.2	FB_SP_ADJUST.1	FB_SP_ADJUST.0	CNTR_ENABLE	FB_EDGE_SHAPE.2	FB_EDGE_SHAPE.1	FB_EDGE_SHAPE.0	01001010	4A
240	F0	FB_CONTROL 4	RW					FB_DELAY.3	FB_DELAY.2	FB_DELAY.1	FB_DELAY.0	01000100	44
241	F1	FB_CONTROL 5	RW	CNTR_LEVEL.1	CNTR_LEVEL.0	FB_LEVEL.1	FB_LEVEL.0	CNTR_MODE.1	CNTR_MODE.0		RGB_IP_SEL	00001100	0C
243	F3	AFE_CONTROL 1	RW	ADC3_SW.3	ADC3_SW.2	ADC3_SW.1	ADC3_SW.0	AA_FILT_EN.3	AA_FILT_EN.2	AA_FILT_EN.1	AA_FILT_EN.0	00000000	00
244	F4	Drive Strength	RW			DR_STR	DR_STR.0	DR_STR_C	DR_STR_C.0	DR_STR_S	DR_STR_S.0	xx010101	15
248	F8	IF Comp Ctrl	RW						IFFILTSEL.2	IFFILTSEL.1	IFFILTSEL.0	00000000	00
249	F9	VS Mode Ctrl	RW					VS_COAST_MODE.1	VS_COAST_MODE.0	EXTEND_VS_MIN_FREQ	EXTEND_VS_MAX_FREQ	00000000	00
251	FB	Peaking Ctrl	RW	PEAKING_GAIN.7	PEAKING_GAIN.6	PEAKING_GAIN.5	PEAKING_GAIN.4	PEAKING_GAIN.3	PEAKING_GAIN.2	PEAKING_GAIN.1	PEAKING_GAIN.0	01000000	40
252	FC	Coring Threshold 2	RW	DNR_TH2.7	DNR_TH2.6	DNR_TH2.5	DNR_TH2.4	DNR_TH2.3	DNR_TH2.2	DNR_TH2.1	DNR_TH2.0	00000100	04

# ADV7184

Table 102 provides a detailed description of the registers located in the User Map.

**Table 102. User Map Detailed Description**

Address	Register	Bit Description	Bit								Comments	Notes		
			7	6	5	4	3	2	1	0				
0x00	Input Control	INSEL [3:0]. The INSEL bits allow the user to select an input channel as well as the input format.					0	0	0	0	CVBS in on AIN1, SCART: G on AIN6/AIN9, B on AIN4/AIN7, R on AIN5/AIN8	Composite and SCART RGB (RGB analog input options selectable via RGB_IP_SEL)		
							0	0	0	1	CVBS in on AIN2, SCART: G on AIN6/AIN9, B on AIN4/AIN7, R on AIN5/AIN8			
							0	0	1	0	CVBS in on AIN3, SCART: G on AIN6/AIN9, B on AIN4/AIN7, R on AIN5/AIN8			
							0	0	1	1	CVBS in on AIN4, SCART: G on AIN9, B on AIN7, R on AIN8			
							0	1	0	0	CVBS in on AIN5, SCART: G on AIN9, B on AIN7, R on AIN8			
							0	1	0	1	CVBS in on AIN6, SCART: G on AIN9, B on AIN7, R on AIN8			
							0	1	1	0	Y on AIN1, C on AIN4		S-Video	
							0	1	1	1	Y on AIN2, C on AIN5			
							1	0	0	0	Y on AIN3, C on AIN6			
							1	0	0	1	Y on AIN1, Pb on AIN4, Pr on AIN5		YPbPr	
							1	0	1	0	Y on AIN2, Pb on AIN3, Pr on AIN6			
							1	0	1	1	CVBS in on AIN7, SCART: G on AIN6, B on AIN4, R on AIN5		Composite and SCART RGB (RGB analog input options selectable via RGB_IP_SEL)	
							1	1	0	0	CVBS in on AIN8, SCART: G on AIN6, B on AIN4, R on AIN5			
						1	1	0	1	CVBS in on AIN9, SCART: G on AIN6, B on AIN4, R on AIN5				
						1	1	1	0	CVBS in on AIN10, SCART: G on AIN6/AIN9, B on AIN4/AIN7, R on AIN5/AIN8				
						1	1	1	1	CVBS in on AIN11, SCART: G on AIN6/AIN9, B on AIN4/AIN7, R on AIN5/AIN8				
				VID_SEL [7:3]. The VID_SEL bits allow the user to select the input video standard.	0	0	0	0				Auto-detect PAL (BGHID), NTSC (without pedestal), SECAM		
					0	0	0	1						Auto-detect PAL (BGHID), NTSC (M) (with pedestal), SECAM
					0	0	1	0						Auto-detect PAL (N), NTSC (M) (without pedestal), SECAM
					0	0	1	1						Auto-detect PAL (N), NTSC (M) (with pedestal), SECAM
					0	1	0	0						NTSC(J)
					0	1	0	1						NTSC(M)
					0	1	1	0						PAL 60
		0	1		1	1					NTSC 4.43			
		1	0		0	0					PAL BGHID			
		1	0		0	1					PAL N (BGHID without pedestal)			
		1	0		1	0					PAL M (without pedestal)			
		1	0		1	1					PAL M			
		1	1		0	0					PAL combination N			
		1	1		0	1					PAL combination N			
		1	1		1	0					SECAM (with pedestal)			
		1	1	1	1					SECAM (with pedestal)				
0x01	Video Selection	Reserved.					0	0	0	Set to default				
		ENVSPROC					0			Disable VSYNC processor				
							1			Enable VSYNC processor				
		Reserved.				0				Set to default				
		BETACAM			0					Standard video input				
					1					Betacam input enable				
		ENHSPLL		0						Disable HSYNC processor				
				1						Enable HSYNC processor				
	Reserved.	1							Set to default					

Address	Register	Bit Description	Bit								Comments	Notes	
			7	6	5	4	3	2	1	0			
0x03	Output Control	SD_DUP_AV. Duplicates the AV codes from the luma into the chroma path.								0	AV codes to suit 8-bit interleaved data output		
										1	AV codes duplicated (for 16-bit interfaces)		
		Reserved.								0	Set as default		
		OF_SEL [3:0]. Allows the user to choose from a set of output formats.		0	0	0	0	0				Reserved	
				0	0	0	0	1				Reserved	
				0	0	1	0					16-bit @ LLC1 4:2:2	
				0	0	1	1					8-bit @ LLC1 4:2:2 ITU-R BT.656	
				0	1	0	0					Not used	
				0	1	0	1					Not used	
				0	1	1	0					Not used	
				0	1	1	1					Not used	
				1	0	0	0					Not used	
				1	0	0	1					Not used	
				1	0	1	0					Not used	
				1	0	1	1					Not used	
				1	1	0	0					Not used	
			1	1	0	1					Not used		
	1	1	1	1					Not used				
	TOD. Three-state output drivers. This bit allows the user to three-state the output drivers: P[19:0], HS, VS, FIELD, and SFL.	0								Output pins enabled	See also TIM_OE and TRI_LLC		
		1								Drivers three-stated			
	VBI_EN. Allows VBI data (Lines 1 to 21) to be passed through with only a minimum amount of filtering performed.	0								All lines filtered and scaled			
		1								Only active video region filtered			
0x04	Extended Output Control	RANGE. Allows the user to select the range of output values. Can be BT656 compliant, or can fill the whole accessible number range.								0	16 < Y < 235, 16 < C < 240	ITU-R BT.656	
											1	1 < Y < 254, 1 < C < 254	Extended range
		EN_SFL_PIN									0	SFL output is disabled	SFL output enables connecting encoder and decoder directly
											1	SFL information output on the SFL pin	
		BL_C_VBI. Blank chroma during VBI. If set, enables data in the VBI region to be passed through the decoder undistorted.									0	Decode and output color	During VBI
											1	Blank Cr and Cb	
		TIM_OE. Timing signals output enable.									0	HS, VS, F three-stated	Controlled by TOD
											1	HS, VS, F forced active	
		Reserved.			x	x							
		Reserved.			1								
BT656-4. Allows the user to select an output mode-compatible with ITU-R BT656-3/4.		0								BT656-3-compatible			
		1								BT656-4-compatible			
0x07	Autodetect Enable	AD_PAL_EN. PAL B/G/I/H autodetect enable.								0	Disable		
											1	Enable	
		AD_NTSC_EN. NTSC autodetect enable.									0	Disable	
											1	Enable	
		AD_PALM_EN. PAL M autodetect enable.									0	Disable	
											1	Enable	
		AD_PALN_EN. PAL N autodetect enable.									0	Disable	
											1	Enable	
		AD_P60_EN. PAL 60 autodetect enable.									0	Disable	
											1	Enable	
AD_N443_EN. NTSC443 autodetect enable.		0								Disable			
		1								Enable			
AD_SECAM_EN. SECAM autodetect enable.		0								Disable			
		1								Enable			
AD_SEC525_EN. SECAM 525 autodetect enable.		0								Disable			
		1								Enable			
0x08	Contrast Register	CON[7:0]. Contrast adjust. This is the user control for contrast adjustment.	1	0	0	0	0	0	0	0	Luma gain = 1	0x00 Gain = 0; 0x80 Gain = 1; 0xFF Gain = 2	
0x09	Reserved.	Reserved.	1	0	0	0	0	0	0	0			

# ADV7184

Address	Register	Bit Description	Bit								Comments	Notes		
			7	6	5	4	3	2	1	0				
0x0A	Brightness Register	BRI[7:0]. This register controls the brightness of the video signal.	0	0	0	0	0	0	0	0	0		0x00 = 0mV 0x7F = +204mV 0x80 = -204mV	
0x0B	Hue Register	HUE[7:0]. This register contains the value for the color hue adjustment.	0	0	0	0	0	0	0	0	0		Hue range = -90° to +90°	
0x0C	Default Value Y	DEF_VAL_EN. Default value enable.									0	Free-run mode dependent on DEF_VAL_AUTO_EN	When lock is lost, free-run mode can be enabled to output stable timing, clock, and a set color.	
											1	Force free-run mode on and output blue screen		
		DEF_VAL_AUTO_EN. Default value.										0		Disable free-run mode
												1		Enable automatic free-run mode (blue screen)
0x0D	Default Value C	DEF_Y[5:0]. Default value Y. This register holds the Y default value.	0	0	1	1	0	1				Y[7:0] = {DEF_Y[5:0],0,0}	Default Y value output in free-run mode.	
		DEF_C[7:0]. Default value C. The Cr and Cb default values are defined in this register.	0	1	1	1	1	1	0	0		Cr[7:0] = DEF_C[7:4],0,0,0,0 Cb[7:0] = DEF_C[3:0],0,0,0,0		
0x0E	ADI Control	Reserved..					0	0	0	0	0	Set as default		
		SUB_USR_EN. Enables the user to access the User Sub Map				0						Access User Map	See Figure 46.	
					1							Access User Sub Map		
		Reserved.	0	0									Set as default	
0x0F	Power Management	Reserved.									0	Set to default		
		FB_PWRDN									0	FB input operational		
											1	FB input in power save mode		
		PDBP. Power-down bit priority selects between PWRDN bit or pin.						0				Chip power-down controlled by pin		
								1				Bit has priority (pin disregarded)		
		Reserved.				0	0					Set to default		
		PWRDN. Power-down places the decoder in a full power-down mode.			0							System functional		
					1							Powered down	See PDBP, 0x0F Bit 2.	
		Reserved.	0									Set to default		
		RES. Chip Reset loads all I <sup>2</sup> C bits with default values.	0									Normal operation		
	1									Start reset sequence	Executing reset takes approx. 2 ms. Self-clearing.			
0x10	Status Register 1 (Read Only)	IN_LOCK									x	In lock (right now) = 1	Provides information about the internal status of the decoder.	
		LOST_LOCK									x	Lost lock (since last read) = 1		
		FSC_LOCK							x			Fsc lock (right now) = 1		
		FOLLOW_PW					x					Peak white AGC mode active = 1		
		AD_RESULT[2:0]. Autodetection result reports the standard of the Input video.	0	0	0	0						NTSM-MJ	Detected standard	
			0	0	1							NTSC-443		
			0	1	0							PAL-M		
			0	1	1							PAL-60		
			1	0	0							PAL-BGHID		
			1	0	1							SECAM		
1	1		0							PAL combination N				
1	1	1							SECAM 525					
COL_KILL	x									Color kill is active = 1	Color Kill			
0x12	Status Register 2 (Read Only)	MVCS DET									x	MV color striping detected	1 = Detected	
		MVCS T3									x	MV color striping type	0 = Type 2; 1 = Type 3	
		MV_PS DET							x			MV pseudo Sync detected	1 = Detected	
		MV_AGC DET					x					MV AGC pulses detected	1 = Detected	
		LL_NSTD				x						Nonstandard line length	1 = Detected	
		FSC_NSTD			x							Fsc frequency nonstandard	1 = Detected	
		Reserved.	x	x										
0x13	Status Register 3 (Read only)	INST_HLOCK									x	1 = horizontal lock achieved	Unfiltered	
		GEMD									x	1 = Gemstar Data detected	When GEMD bit goes HIGH, it will remain HIGH until end of active video lines in that field.	
		SD_OP_50HZ							x			SD field rate detect	0 = SD 60 Hz detected; 1 = SD 50 Hz detected.	
		CVBS						x				Result of CVBS/YC autodetection	0 = Y/C; 1 = CVBS	
		FREE_RUN_ACT				x						1 = Free-run mode active	Blue screen output	
		STD_FLD_LEN			x							1 = Field length standard	Correct field length found	
		INTERLACED		x								1 = Interlaced video detected	Field sequence found	

Address	Register	Bit Description	Bit								Comments	Notes					
			7	6	5	4	3	2	1	0							
		PAL_SW_LOCK	x									1 = Swinging burst detected	Reliable swinging burst sequence				
0x13	Analogue Control Internal (Write Only)	Reserved.								0	0						
		XTAL_TTL_SEL							0				Crystal used to derive 28.63636 MHz clock				
		Reserved.	0	0	0	0	0			1			External TTL level clock supplied				
0x14	Analog Clamp Control	Reserved.						0	0	1	0		Set to default				
		CCLEN. Current clamp enable allows the user to switch off the current sources in the analog front.				0								Current sources switched off			
		Reserved.	0	0	0									Current sources enabled			
0x15	Digital Clamp Control 1	Reserved.	0	0	0								Set to default				
		DCT[1:0]. Digital clamp timing determines the time constant of the digital fine clamp circuitry.	0	0										Slow (TC = 1 sec)			
			0	1										Medium (TC = 0.5 sec)			
			1	0										Fast (TC = 0.1 sec)			
		Reserved.	0	0	0									TC dependent on video			
0x17	Shaping Filter Control	YFSM[4:0]. Selects Y-shaping filter mode when in CVBS only mode.				0	0	0	0	0	0		Auto wide notch for poor quality sources or wide-band filter with Comb for good quality input	Decoder selects optimum Y-shaping filter depending on CVBS quality.			
		Allows the user to select a wide range of low-pass and notch filters.				0	0	0	0	0	1		Auto narrow notch for poor quality sources or wideband filter with comb for good quality input				
		If either auto mode is selected, the decoder selects the optimum Y filter depending on the CVBS video source quality (good vs. bad).					0	0	0	1	0			SVHS 1	If one of these modes is selected, the decoder does not change filter modes. Depending on video quality, a fixed filter response (the one selected) is used for good and bad quality video.		
						0	0	0	1	1				SVHS 2			
						0	0	1	0	0				SVHS 3			
						0	0	1	0	1				SVHS 4			
						0	0	1	1	0				SVHS 5			
						0	0	1	1	1				SVHS 6			
						0	1	0	0	0				SVHS 7			
						0	1	0	0	1				SVHS 8			
						0	1	0	1	0				SVHS 9			
						0	1	0	1	1				SVHS 10			
						0	1	1	0	0				SVHS 11			
						0	1	1	0	1				SVHS 12			
						0	1	1	1	0				SVHS 13			
						0	1	1	1	1				SVHS 14			
						1	0	0	0	0				SVHS 15			
						1	0	0	0	1				SVHS 16			
						1	0	0	1	0				SVHS 17			
						1	0	0	1	1				SVHS 18 (CCIR601)			
						1	0	1	0	0				PAL NN1			
					1	0	1	0	1				PAL NN2				
					1	0	1	1	0				PAL NN3				
			1	0	1	1	1				PAL WN 1						
			1	1	0	0	0				PAL WN 2						
			1	1	0	0	1				NTSC NN1						
			1	1	0	1	0				NTSC NN2						
			1	1	0	1	1				NTSC NN3						
			1	1	1	0	0				NTSC WN1						
			1	1	1	0	1				NTSC WN2						
			1	1	1	1	0				NTSC WN3						
			1	1	1	1	1				Reserved						
0x17	Shaping Filter Control (cont.)	CSFM[2:0].	0	0	0								Auto selection 15 MHz	Automatically selects a C filter based on video standard and quality.			
		C-shaping filter mode allows the selection from a range of low-pass chrominance filters.	0	0	1										Auto selection 2.17 MHz		
		If either auto mode is selected, the decoder selects the optimum C filter depending on the CVBS video source quality (good vs. bad). Non-auto settings force a C filter for all standards and quality of CVBS video.		0	1	0										SH1	Selects a C filter for all video standards and for good and bad video.
				0	1	1										SH2	
				1	0	0										SH3	
				1	0	1										SH4	
	1		1	0									SH5				
	1	1	1									Wideband mode					
0x18	Shaping Filter Control 2	WYSFM[4:0]. Wideband Y-shaping filter mode allows the user to select which Y shaping filter is used for the Y component				0	0	0	0	0	0		Reserved. Do not use.				
					0	0	0	0	0	1			Reserved. Do not use.				
					0	0	0	1	0				SVHS 1				

# ADV7184

Address	Register	Bit Description	Bit								Comments	Notes	
			7	6	5	4	3	2	1	0			
		of Y/C, YPbPr, B/W input signals; it is also used when a good quality input CVBS signal is detected. For all other inputs, the Y- shaping filter chosen is controlled by YSFM[4:0].				0	0	0	1	1	SVHS 2		
						0	0	1	0	0	SVHS 3		
						0	0	1	0	1	SVHS 4		
						0	0	1	1	0	SVHS 5		
						0	0	1	1	1	SVHS 6		
						0	1	0	0	0	SVHS 7		
						0	1	0	0	1	SVHS 8		
						0	1	0	1	0	SVHS 9		
						0	1	0	1	1	SVHS 10		
						0	1	1	0	0	SVHS 11		
						0	1	1	0	1	SVHS 12		
						0	1	1	1	0	SVHS 13		
						0	1	1	1	1	SVHS 14		
						1	0	0	0	0	SVHS 15		
						1	0	0	0	1	SVHS 16		
						1	0	0	1	0	SVHS 17		
						1	0	0	1	1	SVHS 18 (CCIR 601)		
					Reserved.	1	0	1	0	0	Reserved. Do not use.		
		Reserved.	~	~	~	~	~	Reserved. Do not use.					
		Reserved.	1	1	1	1	1	Reserved. Do not use.					
		Reserved.	0	0				Set to default					
		WYSFMOVR. Enables the use of automatic WYSFN filter.	0					Auto selection of best filter					
			1					Manual select filter using WYSFM[4:0]					
0x19	Comb Filter Control	PSFSEL[1:0]. Controls the signal bandwidth that is fed to the comb filters (PAL).						0	0	Narrow			
								0	1	Medium			
								1	0	Wide			
								1	1	Widest			
		NSFSEL[1:0]. Controls the signal bandwidth that is fed to the comb filters (NTSC).					0	0		Narrow			
							0	1		Medium			
							1	0		Medium			
							1	1		Wide			
		Reserved.	1	1	1	1		Set as default					
0x1D	ADI Control 2	Reserved.		0	0	0	x	x	x	Set to default			
		EN28XTAL	0							Use 27 MHz crystal			
			1							Use 28.63636 MHz crystal			
		TRI_LLC	0							LLC pin active			
			1						LLC pin three-stated				
0x27	Pixel Delay Control	LTA[1:0]. Luma timing adjust allows the user to specify a timing difference between chroma and luma samples.						0	0	No Delay	CVBS mode LTA[1:0] = 00b S-Video mode LTA[1:0] = 01b YPrPb mode LTA[1:0] = 01b		
								1	0	Luma 1 clk (37 nS) delayed			
								1	0	Luma 2 clk (74 nS) early			
								1	1	Luma 1 clk (37 nS) early			
		Reserved.					0			Set to Zero			
			CTA[2:0]. Chroma timing adjust allows a specified timing difference between the luma and chroma samples.		0	0	0					Not valid setting	CVBS mode CTA[2:0] = 011b S-Video mode CTA[2:0] = 101b YPrPb mode CTA[2:0] = 110b
					0	0	1					Chroma + 2 pixels (early)	
					0	1	0					Chroma + 1 pixel (early)	
				0	1	1				No delay			
			1	0	0					Chroma - 1 pixel (late)			
			1	0	1					Chroma - 2 pixels (late)			
			1	1	0					Chroma - 3 pixels (late)			
			1	1	1					Not valid setting			
		AUTO_PDC_EN. Automatically programs the LTA/CTA values to align luma and chroma at the output for all modes of operation.	0							Use values in LTA[1:0] and CTA[2:0] for delaying luma/chroma			
1								LTA and CTA values determined automatically					
SWPC. Allows the Cr and Cb samples to be swapped.	0							No Swapping					
	1							Swap the Cr and Cb O/P samples					
0x2B	Misc Gain Control	PW_UPD. Peak white update determines the rate of gain.						0	Update once per video line	Peak white must be enabled. See LAGC[2:0]			
								1	Update once per field				
		Reserved.		1	0	0	0	0	Set to default				
		CKE. Color kill enable allows the color kill	0						Color kill disabled		For SECAM color kill, threshold		

Address	Register	Bit Description	Bit								Comments	Notes	
			7	6	5	4	3	2	1	0			
		function to be switched on and off.		1								Color kill enabled	is set at 8%. See CKILLTHR[2:0]
		Reserved.	1									Set to default	
0x2C	AGC Mode Control	CAGC[1:0]. Chroma automatic gain control selects the basic mode of operation for the AGC in the chroma path.								0	0	Manual fixed gain	Use CMG[11:0]
										0	1	Use luma gain for chroma	
										1	0	Automatic gain	Based on color burst
										1	1	Freeze chroma gain	
		Reserved.				1	1					Set to 1	
		LAGC[2:0]. Luma automatic gain control selects the mode of operation for the gain control in the luma path.	0	0	0							Manual fixed gain	Use LMG[11:0]
			0	0	1							AGC peak white algorithm off	Blank level to sync tip
			0	1	0							AGC peak white algorithm on	Blank level to sync tip
			0	1	1							Reserved	
			1	0	0							Reserved	
			1	0	1							Reserved	
			1	1	0							Reserved	
			1	1	1							Freeze gain	
		Reserved.	1									Set to 1	
0x2D	Chroma Gain Control 1	CMG[11:8]. Chroma manual gain can be used to program a desired manual chroma gain. Reading back from this register in AGC mode gives the current gain.					0	1	0	0			CAGC[1:0] settings decide in which mode CMG[11:0] operates
		Reserved.			1	1						Set to 1	
		CAGT[1:0]. Chroma automatic gain timing allows adjustment of the chroma AGC tracking speed.	0	0								Slow (TC = 2 s)	Has an effect only if CAGC[1:0] is set to auto gain (10)
			0	1								Medium (TC = 1 s)	
			1	0								Fast (TC = 0.2 s)	
			1	1								Adaptive	
0x2E	Chroma Gain Control 2	CMG[7:0]. Chroma manual gain lower 8 bits. See CMG[11:8] for description.	0	0	0	0	0	0	0	0	0	CMG[11:0] = 750d; gain is 1 in NTSC CMG[11:0] = 741d; gain is 1 in PAL	Min value is 0d (G = -60 dB) Max value is 3750 (G = 5)
0x2F	Luma Gain Control 1	LMG[11:8]. Luma manual gain can be used to program a desired manual chroma gain, or to read back the actual gain value used.					x	x	x	x		LAGC[1:0] settings decide in which mode LMG[11:0] operates	
		Reserved.			1	1						Set to 1	
		LAGT[1:0]. Luma automatic gain timing allows adjustment of the luma AGC tracking speed.	0	0								Slow (TC = 2 s)	Only has an effect if LAGC[1:0] is set to auto gain (001, 010, 011, or 100)
			0	1								Medium (TC = 1 s)	
			1	0								Fast (TC = 0.2 s)	
			1	1								Adaptive	
0x30	Luma Gain Control 2	LMG[7:0]. Luma manual gain can be used to program a desired manual chroma gain or read back the actual used gain value.	x	x	x	x	x	x	x	x	x	LMG[11:0] = 1128dec; gain is 1 in NTSC LMG[11:0] = 1222d; gain is 1 in PAL	Min value NTSC 1024 (G = 0.90); PAL (G = 0.84) Max value NTSC 4095 (G = 3.63); PAL (G = 3.35)
0x31	VS and FIELD Control 1	Reserved.							0	1	0	Set to default	
		HVSTIM. Selects where within a line of video the VS signal is asserted.					0					Start of line relative to HSE	HSE = HSYNC end
							1					Start of line relative to HSB	HSB = HSYNC begin
		NEWAVMODE. Sets the EAV/SAV mode.				0						EAV/SAV codes generated to suit ADI encoders	
						1						Manual VS/Field position controlled by Registers 0x32, 0x33, and 0xE5-0xEA	
		Reserved.	0	0	0							Set to default	
0x32	VSYNC Field Control 2	Reserved.											NEWAVMODE bit must be set high.
					0	0	0	0	0	0	1	Set to default	
		VSBHE	0									VS goes high in the middle of the line (even field)	
			1									VS changes state at the start of the line (even field)	
		VSBHO	0									VS goes high in the middle of the line (odd field)	
			1									VS changes state at the start of the line (odd field)	
0x33	VSYNC Field Control 3	Reserved.			0	0	0	1	0	0		Set to default	
		VSEHE	0									VS goes low in the middle of the line (even field)	NEWAVMODE bit must be set high.
			1									VS changes state at the start of the line (even field)	

# ADV7184

Address	Register	Bit Description	Bit								Comments	Notes				
			7	6	5	4	3	2	1	0						
		VSEHO	0									VS goes low in the middle of the line (odd field)				
			1									VS changes state at the start of the line odd field				
0x34	HS Position Control 1	HSE[10:8]. HS end allows the positioning of the HS output within the video line.							0	0	0	HS output ends HSE[10:0] pixels after the falling edge of HSYNC	Using HSB and HSE the user can program the position and length of the output HSYNC			
		Reserved.					0					Set to 0				
		HSB[10:8]. HS begin allows the positioning of the HS output within the video line.		0	0	0							HS output starts HSB[10:0] pixels after the falling edge of HSYNC			
		Reserved.	0										Set to 0			
0x35	HS Position Control 2	HSB[7:0]. See above, using HSB[10:0] and HSE[10:0], the user can program the position and length of HS output signal.	0	0	0	0	0	0	0	1	0					
0x36	HS Position Control 3	HSE[7:0]. See above.	0	0	0	0	0	0	0	0	0					
0x37	Polarity	PCLK. Sets the polarity of LLC1.									0	Invert polarity				
											1	Normal polarity as per the timing diagrams				
		Reserved.						0	0				Set to 0			
		PF. Sets the FIELD polarity.					0						Active high			
							1						Active low			
		Reserved.				0							Set to 0			
		PVS. Sets the VS Polarity.			0								Active high			
					1								Active low			
		Reserved.		0									Set to 0			
		PHS. Sets HS Polarity.		0									Active high			
			1									Active low				
0x38	NTSC Comb Control	YCMN[2:0]. Luma Comb Mode, NTSC.						0	0	0		Adaptive 3-line, 3-tap luma				
								1	0	0			Use low-pass notch			
								1	0	1			Fixed luma comb (2-line)	Top lines of memory		
								1	1	0			Fixed luma comb (3-Line)	All lines of memory		
								1	1	1			Fixed luma comb (2-line)	Bottom lines of memory		
			CCMN[2:0]. Chroma Comb Mode, NTSC.			0	0	0						3-line adaptive for CTAPSN = 01 4-line adaptive for CTAPSN = 10 5-line adaptive for CTAPSN = 11		
					1	0	0							Disable chroma comb		
					1	0	1							Fixed 2-line for CTAPSN = 01 Fixed 3-line for CTAPSN = 10 Fixed 4-line for CTAPSN = 11	Top lines of memory	
					1	1	0							Fixed 3-line for CTAPSN = 01 Fixed 4-line for CTAPSN = 10 Fixed 5-line for CTAPSN = 11	All lines of memory	
					1	1	1							Fixed 2-line for CTAPSN = 01 Fixed 3-line for CTAPSN = 10 Fixed 4-line for CTAPSN = 11	Bottom lines of memory	
				CTAPSN[1:0]. Chroma Comb Taps, NTSC.	0	0									Not used	
					0	1									Adapts 3 lines – 2 lines	
			1		0									Adapts 5 lines – 3 lines		
				1	1									Adapts 5 lines – 4 lines		
0x39	PAL Comb Control	YCMP[2:0]. Luma Comb mode, PAL.						0	0	0		Adaptive 5-line, 3-tap luma comb				
								1	0	0			Use low-pass notch			
								1	1	0			Fixed luma comb	Top lines of memory		
								1	1	0			Fixed luma comb (5-line)	All lines of memory		
								1	1	1			Fixed luma comb (3-line)	Bottom lines of memory		
			CCMP[2:0]. Chroma Comb mode, PAL.			0	0	0						3-line adaptive for CTAPSP = 01 4-line adaptive for CTAPSP = 10 5-line adaptive for CTAPSP = 11		
					1	0	0							Disable chroma comb		
					1	0	1							Fixed 2-line for CTAPSP = 01 Fixed 3-line for CTAPSP = 10 Fixed 4-line for CTAPSP = 11	Top lines of memory	
					1	1	0							Fixed 3-line for CTAPSP = 01 Fixed 4-line for CTAPSP = 10 Fixed 5-line for CTAPSP = 11	All lines of memory	
					1	1	1							Fixed 2-line for CTAPSP = 01 Fixed 3-line for CTAPSP = 10 Fixed 4-line for CTAPSP = 11	Bottom lines of memory	

Address	Register	Bit Description	Bit								Comments	Notes			
			7	6	5	4	3	2	1	0					
		CTAPSP[1:0]. Chroma comb taps, PAL.	0	0								Not used			
			0	1								Adapts 5-lines – 2 lines (2 taps)			
			1	0								Adapts 5 lines – 3 lines (3 taps)			
			1	1								Adapts 5 lines – 4 lines (4 taps)			
0x3A	ADC Control	PWRDN_ADC_3. Enables power-down of ADC3.									0	ADC3 normal operation			
												1	Power down ADC3		
			PWRDN_ADC_2. Enables power-down of ADC2.									0	ADC2 normal operation		
												1	Power down ADC2		
			PWRDN_ADC_1. Enables power-down of ADC1.									0	ADC1 normal operation		
												1	Power down ADC1		
		PWRDN_ADC_0. Enables power-down of ADC0.									0	ADC0 normal operation			
											1	Power down ADC0			
		Reserved.	0	0	0	1							Set as default		
0x3D	Manual Window Control	Reserved.					0	0	1	1			Set to default		
			CKILLTHR[2:0].	0	0	0								Kill at 0.5%	CKE = 1 enables the color kill function and must be enabled for CKILLTHR[2:0] to take effect.
				0	0	1								Kill at 1.5%	
				0	1	0								Kill at 2.5%	
				0	1	1								Kill at 4%	
				1	0	0								Kill at 8.5%	
				1	0	1								Kill at 16%	
				1	1	0								Kill at 32%	
				1	1	1								Reserved	
		Reserved.	0										Set to default		
0x41	Resample Control	Reserved.			0	0	0	0	0	0	1		Set to default		
			SFL_INV. Controls the behavior of the PAL switch bit.	0										SFL compatible with ADV7190/ADV7191/ ADV7194 & ADV73xx encoders	
				1										SFL compatible with ADV717x encoders	
		Reserved.	0										Set to default		
0x48	Gemstar Control 1	GDECEL[15:8]. See the Comments column.	0	0	0	0	0	0	0	0	0		GDECEL[15:0]. 16 individual enable bits that select the lines of video (even field Lines 10–25) that the decoder checks for Gemstar-compatible data.	LSB = Line 10; MSB = Line 25 Default = Do not check for Gemstar-compatible data on any lines [10–25] in even fields	
0x49	Gemstar Control 2	GDECEL[7:0]. See above.	0	0	0	0	0	0	0	0	0				
0x4A	Gemstar Control 3	GDECOL[15:8]. See the Comments column.	0	0	0	0	0	0	0	0	0		GDECOL[15:0]. 16 individual enable bits that select the lines of video (odd field Lines 10–25) that the decoder checks for Gemstar-compatible data.	LSB = Line 10; MSB = Line 25 Default = Do not check for Gemstar-compatible data on any lines [10–25] in odd fields	
0x4B	Gemstar Control 4	GDECOL[7:0]. See above.	0	0	0	0	0	0	0	0	0				
0x4C	Gemstar Control 5	GDECAD. Controls the manner in which decoded Gemstar data is inserted into the horizontal blanking period.									0	Split data into half byte	To avoid 00/FF code.		
											1	Output in straight 8-bit format			
			Reserved.	x	x	x	x	0	0	0			Undefined		
0x4D	CTI DNR Control 1	CTI_EN. CTI enable									0	Disable CTI			
												1	Enable CTI		
			CTI_AB_EN. Enables the mixing of the transient improved chroma with the original signal.									0	Disable CTI alpha blender		
												1	Enable CTI alpha blender		
			CTI_AB[1:0]. Controls the behavior of the alpha-blend circuitry.					0	0					Sharpest mixing	
								0	1					Sharp mixing	
								1	0					Smooth	
								1	1					Smoothest	
		Reserved.					0						Set to default		
		DNR_EN. Enable or bypass the DNR block.			0								Bypass the DNR block		
					1								Enable the DNR block		
		Reserved.	1	1									Set to default		
0x4E	CTI DNR Control 2	CTI_CTH[7:0]. Specifies how big the amplitude step must be to be steepened by the CTI block.	0	0	0	0	1	0	0	0	0		Set to 0x04 for A/V input; set to 0x0A for tuner input		
0x50	CTI DNR Control 4	DNR_TH[7:0]. Specifies the maximum edge that is interpreted as noise and is therefore blanked.	0	0	0	0	1	0	0	0	0				
0x51	Lock Count	CIL[2:0]. Count-into-lock determines the number of lines the system must remain in						0	0	0			1 line of video		
									0	0	1			2 lines of video	

# ADV7184

Address	Register	Bit Description	Bit								Comments	Notes
			7	6	5	4	3	2	1	0		
		lock before showing a locked status.						0	1	0	5 lines of video	
								0	1	1	10 lines of video	
								1	0	0	100 lines of video	
								1	0	1	500 lines of video	
								1	1	0	1000 lines of video	
								1	1	1	100000 lines of video	
		COL[2:0]. Count-out-of-lock determines the number of lines the system must remain out-of-lock before showing a lost-locked status.		0	0	0					1 line of video	
				0	0	1					2 lines of video	
				0	1	0					5 lines of video	
				0	1	1					10 lines of video	
				1	0	0					100 lines of video	
				1	0	1					500 lines of video	
		SRLS. Select raw lock signal. Selects the determination of the lock status.		1	1	0					1000 lines of video	
				1	1	1					100000 lines of video	
		FSCLE. Fsc lock enable.		0							Over field with vertical info	
				1							Line-to-line evaluation	
			0							Lock status set only by horizontal lock		
			1								Lock status set by horizontal lock and subcarrier lock.	
0x69	Config 1	SDM_SEL[1:0]						0	0	INSEL selects Analog I/P Muxing		
								0	1	CVBS – AIN11		
								1	0	S-Video – Y on AIN10 and C on AIN12		
								1	1	CVBS/S-Video autodetect CVBS on AIN11 Y on AIN11 C on AIN12		
						0	0	0	0	x		Reserved.
0x8F	Free Run Line Length 1	Reserved.					0	0	0	0	Set to default	
				0	0	0					LLC1 (nominal 27 MHz) selected out on LLC1 pin	
				1	0	1					LLC2 (nominally 13.5 MHz) selected out on LLC1 pin	
		Reserved.	0							Set to default		
0x99	CCAP1 (Read Only)	CCAP1[7:0]. Closed caption data register.	x	x	x	x	x	x	x	x	CCAP1[7] contains parity bit for byte 0	Only for use with VBI System 2
0x9A	CCAP2 (Read Only)	CCAP2[7:0]. Closed caption data register.	x	x	x	x	x	x	x	x	CCAP2[7] contains parity bit for byte 0	Only for use with VBI System 2
0x9B	Letterbox 1 (Read Only)	LB_LCT[7:0]. Letterbox data register.	x	x	x	x	x	x	x	x	Reports the number of black lines detected at the top of active video.	This feature examines the active video at the start and at the end of each field. It enables format detection even if the video is not accompanied by a CGMS or WSS sequence.
0x9C	Letterbox 2 (Read Only)	LB_LCM[7:0]. Letterbox data register.	x	x	x	x	x	x	x	x	Reports the number of black lines detected in the bottom half of active video if subtitles are detected.	
0x9D	Letterbox 3 (Read Only)	LB_LCB[7:0]. Letterbox data register.	x	x	x	x	x	x	x	x	Reports the number of black lines detected at the bottom of active video.	
0xC3	ADC SWITCH 1	ADC0_SW[3:0]. Manual muxing control for ADC0.					0	0	0	0	No connection	SETADC_SW_MAN_EN = 1
							0	0	0	1	AIN1	
							0	0	1	0	AIN2	
							0	0	1	1	AIN3	
							0	1	0	0	AIN4	
							0	1	0	1	AIN5	
							0	1	1	0	AIN6	
							0	1	1	1	No connection	
							1	0	0	0	No connection	
							1	0	0	1	AIN7	
							1	0	1	0	AIN8	
							1	0	1	1	AIN9	
							1	1	0	0	AIN10	
				1	1	0	1	AIN11				
				1	1	1	0	AIN12				
				1	1	1	1	No connection				
0xC3	ADC SWITCH 1	ADC1_SW[3:0]. Manual muxing control for	0	0	0	0					No connection	SETADC_SW_MAN_EN = 1

Address	Register	Bit Description	Bit								Comments	Notes		
			7	6	5	4	3	2	1	0				
	(cont.)	ADC1.	0	0	0	1						No connection		
			0	0	1	0						No connection		
			0	0	1	1						AIN3		
			0	1	0	0						AIN4		
			0	1	0	1						AIN5		
			0	1	1	0						AIN6		
			0	1	1	1						No connection		
			1	0	0	0						No connection		
			1	0	0	1						No connection		
			1	0	1	0						No connection		
			1	0	1	1						AIN9		
			1	1	0	0						AIN10		
			1	1	0	1						AIN11		
			1	1	1	0						AIN12		
1	1	1	1						No connection					
0xC4	ADC SWITCH 2	ADC2_SW[3:0]. Manual muxing control for ADC2.					0	0	0	0	No connection	SETADC_SW_MAN_EN = 1		
							0	0	0	1	No connection			
							0	0	1	0	AIN2			
							0	0	1	1	No connection			
							0	1	0	0	No connection			
							0	1	0	1	AIN5			
							0	1	1	0	AIN6			
							0	1	1	1	No connection			
							1	0	0	0	No connection			
							1	0	0	1	No connection			
							1	0	1	0	AIN8			
							1	0	1	1	No connection			
							1	1	0	0	No connection			
							1	1	0	1	AIN11			
				1	1	1	0	AIN12						
				1	1	1	1	No connection						
		Reserved.	x	x	x									
		ADC_SW_MAN_EN. Enables manual setting of the input signal muxing.	0							Disable				
			1							Enable				
0xDC	Letterbox Control 1	LB_TH [4:0]. Sets the threshold value that determines if a line is black.					0	1	1	0	0	Default threshold for the detection of black lines.		
		Reserved.	1	0	1							Set as default		
0xDD	Letterbox Control 2	LB_EL[3:0]. Programs the end line of the activity window for LB detection (end of field).					1	1	0	0		LB detection ends with the last line of active video on a field, 1100b: 262/525.		
		LB_SL[3:0]. Programs the start line of the activity window for LB detection (start of field).	0	1	0	0						Letterbox detection aligned with the start of active video, 0100b: 23/286 NTSC.		
0xDE	ST Noise Readback 1 (Read Only)	ST_NOISE[10:0] Sync Tip noise Measurement												
		ST_NOISE[10:8]						x	x	x				
		ST_NOISE_VLD					x							1 = ST_NOISE[10:0] measurement valid 0 = ST_NOISE[10:0] measurement invalid
		Reserved.	x	x	x	x								
0xDF	ST Noise Readback 2 (Read Only)	ST_NOISE[7:0] See ST_NOISE[10:0] above	x	x	x	x	x	x	x	x				
0xE1	SD Offset Cb	SD_OFF_CB [7:0]. Adjusts the hue by selecting the offset for the Cb channel.	1	0	0	0	0	0	0	0	0			
0xE2	SD Offset Cr	SD_OFF_CR [7:0]. Adjusts the hue by selecting the offset for the Cr channel.	1	0	0	0	0	0	0	0	0			
0xE3	SD Saturation Cb	SD_SAT_CB [7:0]. Adjusts the saturation of the picture by affecting gain on the Cb channel.	1	0	0	0	0	0	0	0	0	Chroma gain = 0 dB		
0xE4	SD Saturation Cr	SD_SAT_CR [7:0]. Adjusts the saturation of the picture by affecting gain on the Cr channel.	1	0	0	0	0	0	0	0	0	Chroma gain = 0 dB		
0xE5	NTSC V Bit Begin	NVBEG[4:0]. How many lines after I <sub>COUNT</sub> rollover to set V high.					0	0	1	0	1	NTSC default (BT.656)		

# ADV7184

Address	Register	Bit Description	Bit								Comments	Notes	
			7	6	5	4	3	2	1	0			
		NVBEGSIGN			0							Set to low when manual programming	
					1							Not suitable for user programming	
		NVBEGDELE. Delay V bit going high by one line relative to NVBEG (even field).	0									No delay	
			1									Additional delay by 1 line	
		NVBEGDELO. Delay V bit going high by one line relative to NVBEG (odd field).	0									No delay	
			1								Additional delay by 1 line		
0xE6	NTSC V Bit End	NVEND[4:0]. How many lines after I <sub>COUNT</sub> rollover to set V low.				0	0	1	0	0	NTSC default (BT.656)		
		NVENDSIGN			0						Set to low when manual programming		
					1						Not suitable for user programming		
		NVENDDELE. Delay V bit going low by one line relative to NVEND (even field).	0								No delay		
			1								Additional delay by 1 line		
			0							No delay			
			1							Additional delay by 1 line			
0xE7	NTSC F Bit Toggle	NFTOG[4:0]. How many lines after I <sub>COUNT</sub> rollover to toggle F signal.				0	0	0	1	1	NTSC default		
		NFTOGSIGN			0						Set to low when manual programming		
					1						Not suitable for user programming		
		NFTOGDELE. Delay F transition by one line relative to NFTOG (even field).	0								No delay		
			1								Additional delay by 1 line		
			0							No delay			
			1							Additional delay by 1 line			
0xE8	PAL V Bit Begin	PVBEG[4:0]. How many lines after I <sub>COUNT</sub> rollover to set V high.				0	0	1	0	1	PAL default (BT.656)		
		PVBEGSIGN			0						Set to low when manual programming		
					1						Not suitable for user programming		
		PVBEGDELE. Delay V bit going high by one line relative to PVBEG (even field).	0								No delay		
			1								Additional delay by 1 line		
			0							No delay			
			1							Additional delay by 1 line			
0xE9	PAL V Bit End	PVEND[4:0]. How many lines after I <sub>COUNT</sub> rollover to set V low.				1	0	1	0	0	PAL default (BT.656)		
		PVENDSIGN			0						Set to low when manual programming		
					1						Not suitable for user programming		
		PVENDDELE. Delay V bit going low by one line relative to PVEND (even field).	0								No delay		
			1								Additional delay by 1 line		
			0							No delay			
			1							Additional delay by 1 line			
0xEA	PAL F Bit Toggle	PFTOG[4:0]. How many lines after I <sub>COUNT</sub> rollover to toggle F signal.				0	0	0	1	1	PAL default (BT.656)		
		PFTOGSIGN			0						Set to low when manual programming		
					1						Not suitable for user programming		
		PFTOGDELE. Delay F transition by one line relative to PFTOG (even field).	0								No delay		
			1								Additional delay by 1 line		
			0							No delay			
			1							Additional delay by 1 line			
0xEB	V Blank Control 1	PVBIOLCM[1:0]. PAL VBI even field line control.							0	0	VBI ends 1 line earlier (line 335)	Controls position of first active (comb filtered) line after VBI on even field in PAL	
									0	1	ITU-R BT.470 compliant (Line 336)		
										1	0		VBI ends 1 line later (line 337)
										1	1		VBI ends 2 lines later (line 338)
		PVBIOLCM[1:0]. PAL VBI odd field line control.						0	0	VBI ends 1 line earlier (line 22)	Controls position of first active (comb filtered) line after VBI on odd field in PAL		
								0	1	ITU-R BT.470 compliant (Line 23)			
								1	0	VBI ends 1 line later (line 24)			
								1	1	VBI ends 2 lines later (line 25)			
		NVBIELCM[1:0]. NTSC VBI even field line control.			0	0	VBI ends 1 line earlier (line 282)	Controls position of first active (comb filtered) line after VBI on even field in NTSC					
					0	1	ITU-R BT.470 compliant (Line 283)						
			1	0	VBI ends 1 line later (line 284)								

Address	Register	Bit Description	Bit							Comments	Notes				
			7	6	5	4	3	2	1			0			
		PVBIOLCM[1:0]. NTSC VBI odd field line control.	0	0	1	1						VBI ends 2 lines later (line 285)	Controls position of first active (comb filtered) line after VBI on odd field in NTSC		
			0	1								VBI ends 1 line earlier (line 20)			
			1	0								ITU-R BT.470 compliant (Line 21)			
			1	1								VBI ends 1 line later (line 22)			
0xEC	V Blank Control 2	PVBIIECCM[1:0]. PAL VBI even field color control.								0	0	Color output beginning line 335	Controls the position of first line that outputs color after VBI on even field in PAL		
										0	1	ITU-R BT.470 compliant color output beginning Line 336			
										1	0	Color output beginning line 337			
										1	1	Color output beginning line 338			
		PVBIIOCCM[1:0]. PAL VBI odd field color control.					0	0				Color output beginning line 22	Controls the position of first line that outputs color after VBI on odd field in PAL		
							0	1				ITU-R BT.470 compliant color output beginning Line 23			
							1	0				Color output beginning line 24			
							1	1				Color output beginning line 25			
		NVBIIECCM[1:0]. NTSC VBI even field color control.			0	0						Color output beginning line 282	Controls the position of first line that outputs color after VBI on even field in NTSC		
					0	1						ITU-R BT.470 compliant color output beginning Line 283			
					1	0						VBI ends 1 line later (line 284)			
					1	1						Color output beginning line 285			
NVBIOCCM[1:0]. NTSC VBI odd field color control.	0	0								Color output beginning line 20	Controls the position of first line that outputs color after VBI on odd field in NTSC				
	0	1								ITU-R BT.470 compliant color output beginning Line 21					
	1	0								Color output beginning line 22					
	1	1								Color output beginning line 23					
0xED	FB_STATUS (Read Only)	Reserved.					x	x	x	x					
		FB_STATUS[3:0]. Provides information about the status of the FB pin. FB_STATUS.0				x						FB_RISE, 1 = There has been a rising edge on FB pin since last I <sup>2</sup> C read	Self-clearing bit		
		FB_STATUS.1			x							FB_FALL, 1 = there has been a falling edge on FB pin since last I <sup>2</sup> C read	Self-clearing bit		
		FB_STATUS.2		x								FB_STAT, Instantaneous value of FB signal at time of I <sup>2</sup> C read			
0xED	FB_CONTROL 1 (Write Only)	FB_MODE[1:0]. Selects FB mode.								0	0	Static switch mode – full RGB or full CVBS data			
										0	1	Fixed alpha blending. See MAN_ALPHA_VAL[6:0]			
										1	0	Dynamic switching (fast mux)			
										1	1	Dynamic switching with edge enhancement			
									0		CVBS source	Selects either CVBS or RGB to be O/P			
									1		RGB source				
									0		FB pin active high				
									1		FB pin active low				
0xEE	FB_CONTROL 2	MAN_ALPHA_VAL[6:0]. Determines in what proportion the video from the CVBS source and the RGB source are blended.	0	0	0	0	0	0	0	0	0				
		FB_CSC_MAN	0											Automatic configuration of the CSC for SCART support	CSC is used to convert RGB portion of SCART signal to YCrCb
			1											Enable manual programming of CSC	
0xEF	FB_CONTROL 3	FB_EDGE_SHAPE[2:0]							0	0	0		Improves picture transition for high speed fast blank switching		
									0	0	1				
									0	1	0				
									0	1	1				
		CNTR_ENABLE					0						Contrast reduction mode disabled – FB signal interpreted as Bi-level signal		

# ADV7184

Address	Register	Bit Description	Bit								Comments	Notes		
			7	6	5	4	3	2	1	0				
0xF0	FB_CONTROL 4						1					Contrast reduction mode enabled – FB signal interpreted as Tri-level signal	Each LSB corresponds to 1/8 of a clock cycle	
		FB_SP_ADJUST	0	1	0	0						Adjusts FB timing in reference to the sampling clock		
		FB_DELAY[3:0]					0	1	0	0		Delay on FB signal in 28.63636 MHz clock cycles		
0xF1	FB_CONTROL 5	Reserved.	0	1	0	0								
		RGB_IP_SEL									0	SD RGB input for FB on AIN7, AIN8 and AIN9		
											1	SD RGB input for FB on AIN4, AIN5 and AIN6		
		Reserved.								0		Set to Zero		
		CNTR_MODE[1:0]. Allows adjustment of contrast level in the contrast reduction box.						0	0				25%	
								0	1				50%	
								1	0				75%	
								1	1				100%	
		FB_LEVEL[1:0]. Controls reference level for fast blank comparator.			0	0							CNTR_ENABLE = 0, FB threshold = 1.4 V CNTR_ENABLE – 1, FB threshold = 1.6 V	
					0	1							CNTR_ENABLE = 0, FB threshold = 1.6 V CNTR_ENABLE – 1, FB threshold = 1.8 V	
					1	0							CNTR_ENABLE = 0, FB threshold = 1.8 V CNTR_ENABLE – 1, FB threshold = 2 V	
					1	1							CNTR_ENABLE = 0, FB threshold = 2 V CNTR_ENABLE – 1, FB threshold = Not Used	
CNTR_LEVEL[1:0]. Controls reference level for contrast reduction comparator.		0	0								0.4 V contrast reduction threshold	CNTR_ENABLE = 1		
		0	1								0.6 V contrast reduction threshold			
		1	0								0.8 V contrast reduction threshold			
		1	1								Not used			
0xF3	AFE_CONTROL 1	AA_FILTER_EN[0]								0	Disables the internal antialiasing filter on Channel 0			
										1	Enables the internal antialiasing filter on Channel 0			
		AA_FILTER_EN[1]								0	Disables the internal antialiasing filter on Channel 1			
										1	Enables the internal antialiasing filter on Channel 1			
		AA_FILTER_EN[2]							0	Disables the internal antialiasing filter on Channel 2				
									1	Enables the internal antialiasing filter on Channel 2				
		AA_FILTER_EN[3]					0				Disables the internal antialiasing filter on Channel 3			
							1				Enables the internal antialiasing filter on Channel 3			
		ADC3_SW[3:0]		0	0	0	0						No connection	
				0	0	0	1						No connection	
				0	0	1	0						No connection	
				0	0	1	1						No connection	
				0	1	0	0						AIN4	
				0	1	0	1						No connection	
				0	1	1	0						No connection	
				0	1	1	1						No connection	
				1	0	0	0						No connection	
	1		0	0	1						AIN7			
	1	0	1	0						No connection				
	1	0	1	1						No connection				
	1	1	0	0						No connection				

Address	Register	Bit Description	Bit								Comments	Notes		
			7	6	5	4	3	2	1	0				
			1	1	0	1						No connection		
			1	1	1	0						No connection		
			1	1	1	1						No connection		
0xF4	Drive Strength	DR_STR_S[1:0]. Selects the drive strength for the sync output signals.								0	0	Reserved		
										0	1	Medium-low drive strength (2x)		
										1	0	Medium-high drive strength (3x)		
										1	1	High drive strength (4x)		
			DR_STR_C[1:0]. Selects the drive strength for the clock output signal.						0	0	Reserved			
									0	1	Medium-low drive strength (2x)			
									1	0	Medium-high drive strength (3x)			
			DR_STR[1:0]. Selects the drive strength for the data output signals. Can be increased or decreased for EMC or crosstalk reasons.						1	1	High drive strength (4x)			
					0	0					Reserved			
					0	1					Medium-low drive strength (2x)			
			Reserved.		1	0						Medium-high drive strength (3x)		
						1	1						High drive strength (4x)	
		Reserved.	x	x								No delay		
0xF8	IF Comp Control	IFFILTSEL[2:0] IF filter selection for PAL and NTSC						0	0	0	Bypass mode	0dB		
												2 MHz	5 MHz	NTSC Filters
									0	0	1	-3 dB	+2 dB	
									0	1	0	-6 dB	+3.5 dB	
									0	1	1	-10 dB	+5 dB	
									1	0	0	Reserved		
												3 MHz	6 MHz	PAL Filters
									1	0	1	-2 dB	+2 dB	
									1	1	0	-5 dB	+3 dB	
									1	1	1	-7 dB	+5 dB	
				Reserved.	0	0	0	0	0	0				
0xF9	VS Mode Control	EXTEND_VS_MAX_FREQ								0	Limit maximum VSYNC frequency to 66.25 Hz (475 lines/frame)			
										1	Limit maximum VSYNC frequency to 70.09 Hz (449 lines/frame)			
			EXTEND_VS_MIN_FREQ							0	Limit minimum VSYNC frequency to 42.75 Hz (731 lines/frame)			
									1	Limit minimum VSYNC frequency to 39.51 Hz (791 lines/frame)				
			VS_COAST_MODE[1:0]					0	0	Auto coast mode		This value sets up the output coast frequency.		
								0	1	50 Hz coast mode				
								1	0	60 Hz coast mode				
		Reserved.					1	1	Reserved					
0xFB	Peaking Control	PEAKING_GAIN[7:0]	0	1	0	0	0	0	0	0	Increases/decreases the gain for high frequency portions of the video signal			
0xFC	Coring Threshold 2	DNR_TH2[7:0]	0	0	0	0	0	1	0	0	Specifies the max. edge that is interpreted as noise and therefore blanked			

# ADV7184

## USER SUB MAP

The collective name for the subaddress registers in Table 103 is User Sub Map. To access the User Sub Map, SUB\_USR\_EN in Register Address 0x0E (User Map) must be programmed to 1.

**Table 103. User Sub Map Register Details**

Address		R W	7	6	5	4	3	2	1	0	Reset	(Hex)
Dec	Hex										Register Name	
64	40	RW	INTRO_DUR_SEL.1	INTRO_DUR_SEL.0	MV_INTRQ_SEL.1	MV_INTRQ_SEL.0		MPU_STIM_I_NTRQ	INTRO_OP_SEL.1	INTRO_OP_SEL.0	0001x000	10
66	42	R		MV_PS_CS_Q	SD_FR_HNG_Q				SD_UNLOCK_Q	SD_LOCK_Q	---	---
67	43	W		MV_PS_CS_CLR	SD_FR_CHNG_CLR				SD_UNLOCK_CLR	SD_LOCK_CLR	x0000000	00
68	44	RW		MV_PS_CS_MSKB	SD_FR_CHNG_MSKB				SD_UNLOCK_MSKB	SD_LOCK_MSKB	x0000000	00
69	45	R	MPU_STIM_INTRQ			EVEN_FIELD				CCAPD	---	---
70	46	R	MPU_STIM_I_NTRQ_Q			SD_FIELD_CHNGD_Q			GEMD_Q	CCAPD_Q	---	---
71	47	W	MPU_STIM_INTRQ_CLR			SD_FIELD_CHNGD_CLR			GEMD_CLR	CCAPD_CLR	0xx00000	00
72	48	RW	MPU_STIM_INTRQ_MSKB			SD_FIELD_CHNGD_MSKB			GEMD_MSKB	CCAPD_MSKB	0xx00000	00
73	49	R				SCM_LOCK		SD_H_LOCK	SD_V_LOCK	SD_OP_50Hz	---	---
74	4A	R			PAL_SW_LK_CHNG_Q	SCM_LOCK_CHNG_Q	SD_AD_CHNG_Q	SD_H_LOCK_CHNG_Q	SD_V_LOCK_CHNG_Q	SD_OP_CHNG_Q	---	---
75	4B	W			PAL_SW_LK_CHNG_CLR	SCM_LOCK_CHNG_CLR	SD_AD_CHNG_CLR	SD_H_LOCK_CHNG_CLR	SD_V_LOCK_CHNG_CLR	SD_OP_CHNG_CLR	xx000000	00
76	4C	RW			PAL_SW_LK_CHNG_MSKB	SCM_LOCK_CHNG_MSKB	SD_AD_CHNG_MSKB	SD_H_LOCK_CHNG_MSKB	SD_V_LOCK_CHNG_MSKB	SD_OP_CHNG_MSKB	xx000000	00
78	4E	R		VDP_VITC_Q		VDP_GS_VPS_PDC_UTC_CHNG_Q		VDP_CGMS_WSS_CHNGD_Q		VDP_CCAPD_Q	---	---
79	4F	W		VDP_VITC_CLR		VDP_GS_VPS_PDC_UTC_CHNG_CLR		VDP_CGMS_WSS_CHNGD_CLR		VDP_CCAPD_CLR	00x0x0x0	00
80	50	RW		VDP_VITC_MSKB		VDP_GS_VPS_PDC_UTC_CHNG_MSKB		VDP_CGMS_WSS_CHNGD_MSKB		VDP_CCAPD_MSKB	00x0x0x0	00
96	60	RW				WST_PKT_DECOD_DISABLE	VDP_TTXT_TYPE_MAN_ENABLE	VDP_TTXT_TYPE_MAN.1	VDP_TTXT_TYPE_MAN.0		10001000	88
97	61	RW				AUTO_DETECT_GS_TYPE					0001xx00	10
98	62	RW	ADF_ENABLE	ADF_MODE.1	ADF_MODE.0	ADF_DID.4	ADF_DID.3	ADF_DID.2	ADF_DID.1	ADF_DID.0	00010101	15
99	63	RW	DUPLICATE ADF		ADF_SDID.5	ADF_SDID.4	ADF_SDID.3	ADF_SDID.2	ADF_SDID.1	ADF_SDID.0	0x101010	2A
100	64	RW	MAN_LINE_PGM				VBI_DATA_P318.3	VBI_DATA_P318.2	VBI_DATA_P318.1	VBI_DATA_P318.0	0xxx0000	00
101	65	RW	VBI_DATA_P6_N23.3	VBI_DATA_P6_N23.2	VBI_DATA_P6_N23.1	VBI_DATA_P6_N23.0	VBI_DATA_P319_N286.3	VBI_DATA_P319_N286.2	VBI_DATA_P319_N286.1	VBI_DATA_P319_N286.0	00000000	00
102	66	RW	VBI_DATA_P7_N24.3	VBI_DATA_P7_N24.2	VBI_DATA_P7_N24.1	VBI_DATA_P7_N24.0	VBI_DATA_P320_N287.3	VBI_DATA_P320_N287.2	VBI_DATA_P320_N287.1	VBI_DATA_P320_N287.0	00000000	00
103	67	RW	VBI_DATA_P8_N25.3	VBI_DATA_P8_N25.2	VBI_DATA_P8_N25.1	VBI_DATA_P8_N25.0	VBI_DATA_P321_N288.3	VBI_DATA_P321_N288.2	VBI_DATA_P321_N288.1	VBI_DATA_P321_N288.0	00000000	00
104	68	RW	VBI_DATA_P9.3	VBI_DATA_P9.2	VBI_DATA_P9.1	VBI_DATA_P9.0	VBI_DATA_P322.3	VBI_DATA_P322.2	VBI_DATA_P322.1	VBI_DATA_P322.0	00000000	00
105	69	RW	VBI_DATA_P10.3	VBI_DATA_P10.2	VBI_DATA_P10.1	VBI_DATA_P10.0	VBI_DATA_P323.3	VBI_DATA_P323.2	VBI_DATA_P323.1	VBI_DATA_P323.0	00000000	00
106	6A	RW	VBI_DATA_P11.3	VBI_DATA_P11.2	VBI_DATA_P11.1	VBI_DATA_P11.0	VBI_DATA_P324_N272.3	VBI_DATA_P324_N272.2	VBI_DATA_P324_N272.1	VBI_DATA_P324_N272.0	00000000	00
107	6B	RW	VBI_DATA_P12_N10.3	VBI_DATA_P12_N10.2	VBI_DATA_P12_N10.1	VBI_DATA_P12_N10.0	VBI_DATA_P325_N273.3	VBI_DATA_P325_N273.2	VBI_DATA_P325_N273.1	VBI_DATA_P325_N273.0	00000000	00
108	6C	RW	VBI_DATA_P13_N11.3	VBI_DATA_P13_N11.2	VBI_DATA_P13_N11.1	VBI_DATA_P13_N11.0	VBI_DATA_P326_N274.3	VBI_DATA_P326_N274.2	VBI_DATA_P326_N274.1	VBI_DATA_P326_N274.0	00000000	00
109	6D	RW	VBI_DATA_P14_N12.3	VBI_DATA_P14_N12.2	VBI_DATA_P14_N12.1	VBI_DATA_P14_N12.0	VBI_DATA_P327_N275.3	VBI_DATA_P327_N275.2	VBI_DATA_P327_N275.1	VBI_DATA_P327_N275.0	00000000	00
110	6E	RW	VBI_DATA_P15_N13.3	VBI_DATA_P15_N13.2	VBI_DATA_P15_N13.1	VBI_DATA_P15_N13.0	VBI_DATA_P328_N276.3	VBI_DATA_P328_N276.2	VBI_DATA_P328_N276.1	VBI_DATA_P328_N276.0	00000000	00
111	6F	RW	VBI_DATA_P16_N14.3	VBI_DATA_P16_N14.2	VBI_DATA_P16_N14.1	VBI_DATA_P16_N14.0	VBI_DATA_P329_N277.3	VBI_DATA_P329_N277.2	VBI_DATA_P329_N277.1	VBI_DATA_P329_N277.0	00000000	00
112	70	RW	VBI_DATA_P17_N15.3	VBI_DATA_P17_N15.2	VBI_DATA_P17_N15.1	VBI_DATA_P17_N15.0	VBI_DATA_P330_N278.3	VBI_DATA_P330_N278.2	VBI_DATA_P330_N278.1	VBI_DATA_P330_N278.0	00000000	00

Address		Register Name	R W	7	6	5	4	3	2	1	0	Reset	(Hex)
Dec	Hex											Value	
113	71	VDP_LINE_01B	RW	VBI_DATA_P18_N16.3	VBI_DATA_P18_N16.2	VBI_DATA_P18_N16.1	VBI_DATA_P18_N16.0	VBI_DATA_P331_N279.3	VBI_DATA_P331_N279.2	VBI_DATA_P331_N279.1	VBI_DATA_P331_N279.0	00000000	00
114	72	VDP_LINE_01C	RW	VBI_DATA_P19_N17.3	VBI_DATA_P19_N17.2	VBI_DATA_P19_N17.1	VBI_DATA_P19_N17.0	VBI_DATA_P332_N280.3	VBI_DATA_P332_N280.2	VBI_DATA_P332_N280.1	VBI_DATA_P332_N280.0	00000000	00
115	73	VDP_LINE_01D	RW	VBI_DATA_P20_N18.3	VBI_DATA_P20_N18.2	VBI_DATA_P20_N18.1	VBI_DATA_P20_N18.0	VBI_DATA_P333_N281.3	VBI_DATA_P333_N281.2	VBI_DATA_P333_N281.1	VBI_DATA_P333_N281.0	00000000	00
116	74	VDP_LINE_01E	RW	VBI_DATA_P21_N19.3	VBI_DATA_P21_N19.2	VBI_DATA_P21_N19.1	VBI_DATA_P21_N19.0	VBI_DATA_P334_N282.3	VBI_DATA_P334_N282.2	VBI_DATA_P334_N282.1	VBI_DATA_P334_N282.0	00000000	00
117	75	VDP_LINE_01F	RW	VBI_DATA_P22_N20.3	VBI_DATA_P22_N20.2	VBI_DATA_P22_N20.1	VBI_DATA_P22_N20.0	VBI_DATA_P335_N283.3	VBI_DATA_P335_N283.2	VBI_DATA_P335_N283.1	VBI_DATA_P335_N283.0	00000000	00
118	76	VDP_LINE_020	RW	VBI_DATA_P23_N21.3	VBI_DATA_P23_N21.2	VBI_DATA_P23_N21.1	VBI_DATA_P23_N21.0	VBI_DATA_P336_N284.3	VBI_DATA_P336_N284.2	VBI_DATA_P336_N284.1	VBI_DATA_P336_N284.0	00000000	00
119	77	VDP_LINE_021	RW	VBI_DATA_P24_N22.3	VBI_DATA_P24_N22.2	VBI_DATA_P24_N22.1	VBI_DATA_P24_N22.0	VBI_DATA_P337_N285.3	VBI_DATA_P337_N285.2	VBI_DATA_P337_N285.1	VBI_DATA_P337_N285.0	00000000	00
120	78	VDP_STATUS_CLEAR	W		VITC_CLEAR		GS_PDC_VPS_UTC_CLEAR		CGMS_WSS_CLEAR		CC_CLEAR	00000000	00
120	78	VDP_STATUS	R	TTXT_AVL	VITC_AVL	GS_DATA_TYPE	GS_PDC_VPS_UTC_AVL		CGMS_WSS_AVL	CC_EVEN_FIELD	CC_AVL	---	---
121	79	VDP_CCAP_DATA_0	R	CCAP_BYTE_1.7	CCAP_BYTE_1.6	CCAP_BYTE_1.5	CCAP_BYTE_1.4	CCAP_BYTE_1.3	CCAP_BYTE_1.2	CCAP_BYTE_1.1	CCAP_BYTE_1.0	---	---
122	7A	VDP_CCAP_DATA_1	R	CCAP_BYTE_2.7	CCAP_BYTE_2.6	CCAP_BYTE_2.5	CCAP_BYTE_2.4	CCAP_BYTE_2.3	CCAP_BYTE_2.2	CCAP_BYTE_2.1	CCAP_BYTE_2.0	---	---
125	7D	CGMS_WSS_DATA_0	R	zero	zero	zero	zero	CGMS_CRC.5	CGMS_CRC.4	CGMS_CRC.3	CGMS_CRC.2	---	---
126	7E	CGMS_WSS_DATA_1	R	CGMS_CRC.1	CGMS_CRC.0	CGMS_WSS.13	CGMS_WSS.12	CGMS_WSS.11	CGMS_WSS.10	CGMS_WSS.9	CGMS_WSS.8	---	---
127	7F	CGMS_WSS_DATA_2	R	CGMS_WSS.7	CGMS_WSS.6	CGMS_WSS.5	CGMS_WSS.4	CGMS_WSS.3	CGMS_WSS.2	CGMS_WSS.1	CGMS_WSS.0	---	---
132	84	VDP_GS_VPS_PDC_UTC_0	R	GS_VPS_PDC_UTC_BYTE_0.7	GS_VPS_PDC_UTC_BYTE_0.6	GS_VPS_PDC_UTC_BYTE_0.5	GS_VPS_PDC_UTC_BYTE_0.4	GS_VPS_PDC_UTC_BYTE_0.3	GS_VPS_PDC_UTC_BYTE_0.2	GS_VPS_PDC_UTC_BYTE_0.1	GS_VPS_PDC_UTC_BYTE_0.0	---	---
133	85	VDP_GS_VPS_PDC_UTC_1	R	GS_VPS_PDC_UTC_BYTE_1.7	GS_VPS_PDC_UTC_BYTE_1.6	GS_VPS_PDC_UTC_BYTE_1.5	GS_VPS_PDC_UTC_BYTE_1.4	GS_VPS_PDC_UTC_BYTE_1.3	GS_VPS_PDC_UTC_BYTE_1.2	GS_VPS_PDC_UTC_BYTE_1.1	GS_VPS_PDC_UTC_BYTE_1.0	---	---
134	86	VDP_GS_VPS_PDC_UTC_2	R	GS_VPS_PDC_UTC_BYTE_2.7	GS_VPS_PDC_UTC_BYTE_2.6	GS_VPS_PDC_UTC_BYTE_2.5	GS_VPS_PDC_UTC_BYTE_2.4	GS_VPS_PDC_UTC_BYTE_2.3	GS_VPS_PDC_UTC_BYTE_2.2	GS_VPS_PDC_UTC_BYTE_2.1	GS_VPS_PDC_UTC_BYTE_2.0	---	---
135	87	VDP_GS_VPS_PDC_UTC_3	R	GS_VPS_PDC_UTC_BYTE_3.7	GS_VPS_PDC_UTC_BYTE_3.6	GS_VPS_PDC_UTC_BYTE_3.5	GS_VPS_PDC_UTC_BYTE_3.4	GS_VPS_PDC_UTC_BYTE_3.3	GS_VPS_PDC_UTC_BYTE_3.2	GS_VPS_PDC_UTC_BYTE_3.1	GS_VPS_PDC_UTC_BYTE_3.0	---	---
136	88	VDP_VPS_PDC_UTC_4	R	VPS_PDC_UTC_BYTE_4.7	VPS_PDC_UTC_BYTE_4.6	VPS_PDC_UTC_BYTE_4.5	VPS_PDC_UTC_BYTE_4.4	VPS_PDC_UTC_BYTE_4.3	VPS_PDC_UTC_BYTE_4.2	VPS_PDC_UTC_BYTE_4.1	VPS_PDC_UTC_BYTE_4.0	---	---
137	89	VDP_VPS_PDC_UTC_5	R	VPS_PDC_UTC_BYTE_5.7	VPS_PDC_UTC_BYTE_5.6	VPS_PDC_UTC_BYTE_5.5	VPS_PDC_UTC_BYTE_5.4	VPS_PDC_UTC_BYTE_5.3	VPS_PDC_UTC_BYTE_5.2	VPS_PDC_UTC_BYTE_5.1	VPS_PDC_UTC_BYTE_5.0	---	---
138	8A	VDP_VPS_PDC_UTC_6	R	VPS_PDC_UTC_BYTE_6.7	VPS_PDC_UTC_BYTE_6.6	VPS_PDC_UTC_BYTE_6.5	VPS_PDC_UTC_BYTE_6.4	VPS_PDC_UTC_BYTE_6.3	VPS_PDC_UTC_BYTE_6.2	VPS_PDC_UTC_BYTE_6.1	VPS_PDC_UTC_BYTE_6.0	---	---
139	8B	VDP_VPS_PDC_UTC_7	R	VPS_PDC_UTC_BYTE_7.7	VPS_PDC_UTC_BYTE_7.6	VPS_PDC_UTC_BYTE_7.5	VPS_PDC_UTC_BYTE_7.4	VPS_PDC_UTC_BYTE_7.3	VPS_PDC_UTC_BYTE_7.2	VPS_PDC_UTC_BYTE_7.1	VPS_PDC_UTC_BYTE_7.0	---	---
140	8C	VDP_VPS_PDC_UTC_8	R	VPS_PDC_UTC_BYTE_8.7	VPS_PDC_UTC_BYTE_8.6	VPS_PDC_UTC_BYTE_8.5	VPS_PDC_UTC_BYTE_8.4	VPS_PDC_UTC_BYTE_8.3	VPS_PDC_UTC_BYTE_8.2	VPS_PDC_UTC_BYTE_8.1	VPS_PDC_UTC_BYTE_8.0	---	---
141	8D	VDP_VPS_PDC_UTC_9	R	VPS_PDC_UTC_BYTE_9.7	VPS_PDC_UTC_BYTE_9.6	VPS_PDC_UTC_BYTE_9.5	VPS_PDC_UTC_BYTE_9.4	VPS_PDC_UTC_BYTE_9.3	VPS_PDC_UTC_BYTE_9.2	VPS_PDC_UTC_BYTE_9.1	VPS_PDC_UTC_BYTE_9.0	---	---
142	8E	VDP_VPS_PDC_UTC_10	R	VPS_PDC_UTC_BYTE_10.7	VPS_PDC_UTC_BYTE_10.6	VPS_PDC_UTC_BYTE_10.5	VPS_PDC_UTC_BYTE_10.4	VPS_PDC_UTC_BYTE_10.3	VPS_PDC_UTC_BYTE_10.2	VPS_PDC_UTC_BYTE_10.1	VPS_PDC_UTC_BYTE_10.0	---	---
143	8F	VDP_VPS_PDC_UTC_11	R	VPS_PDC_UTC_BYTE_11.7	VPS_PDC_UTC_BYTE_11.6	VPS_PDC_UTC_BYTE_11.5	VPS_PDC_UTC_BYTE_11.4	VPS_PDC_UTC_BYTE_11.3	VPS_PDC_UTC_BYTE_11.2	VPS_PDC_UTC_BYTE_11.1	VPS_PDC_UTC_BYTE_11.0	---	---
144	90	VDP_VPS_PDC_UTC_12	R	VPS_PDC_UTC_BYTE_12.7	VPS_PDC_UTC_BYTE_12.6	VPS_PDC_UTC_BYTE_12.5	VPS_PDC_UTC_BYTE_12.4	VPS_PDC_UTC_BYTE_12.3	VPS_PDC_UTC_BYTE_12.2	VPS_PDC_UTC_BYTE_12.1	VPS_PDC_UTC_BYTE_12.0	---	---
146	92	VDP_VITC_DATA_0	R	VITC_DATA_1.7	VITC_DATA_1.6	VITC_DATA_1.5	VITC_DATA_1.4	VITC_DATA_1.3	VITC_DATA_1.2	VITC_DATA_1.1	VITC_DATA_1.0	---	---
147	93	VDP_VITC_DATA_1	R	VITC_DATA_2.7	VITC_DATA_2.6	VITC_DATA_2.5	VITC_DATA_2.4	VITC_DATA_2.3	VITC_DATA_2.2	VITC_DATA_2.1	VITC_DATA_2.0	---	---
148	94	VDP_VITC_DATA_2	R	VITC_DATA_3.7	VITC_DATA_3.6	VITC_DATA_3.5	VITC_DATA_3.4	VITC_DATA_3.3	VITC_DATA_3.2	VITC_DATA_3.1	VITC_DATA_3.0	---	---
149	95	VDP_VITC_DATA_3	R	VITC_DATA_4.7	VITC_DATA_4.6	VITC_DATA_4.5	VITC_DATA_4.4	VITC_DATA_4.3	VITC_DATA_4.2	VITC_DATA_4.1	VITC_DATA_4.0	---	---
150	96	VDP_VITC_DATA_4	R	VITC_DATA_5.7	VITC_DATA_5.6	VITC_DATA_5.5	VITC_DATA_5.4	VITC_DATA_5.3	VITC_DATA_5.2	VITC_DATA_5.1	VITC_DATA_5.0	---	---
151	97	VDP_VITC_DATA_5	R	VITC_DATA_6.7	VITC_DATA_6.6	VITC_DATA_6.5	VITC_DATA_6.4	VITC_DATA_6.3	VITC_DATA_6.2	VITC_DATA_6.1	VITC_DATA_6.0	---	---
152	98	VDP_VITC_DATA_6	R	VITC_DATA_7.7	VITC_DATA_7.6	VITC_DATA_7.5	VITC_DATA_7.4	VITC_DATA_7.3	VITC_DATA_7.2	VITC_DATA_7.1	VITC_DATA_7.0	---	---
153	99	VDP_VITC_DATA_7	R	VITC_DATA_8.7	VITC_DATA_8.6	VITC_DATA_8.5	VITC_DATA_8.4	VITC_DATA_8.3	VITC_DATA_8.2	VITC_DATA_8.1	VITC_DATA_8.0	---	---
154	9A	VDP_VITC_DATA_8	R	VITC_DATA_9.7	VITC_DATA_9.6	VITC_DATA_9.5	VITC_DATA_9.4	VITC_DATA_9.3	VITC_DATA_9.2	VITC_DATA_9.1	VITC_DATA_9.0	---	---
155	9B	VDP_VITC_CALC_CRC	R	VITC_CRC.7	VITC_CRC.6	VITC_CRC.5	VITC_CRC.4	VITC_CRC.3	VITC_CRC.2	VITC_CRC.1	VITC_CRC.0	---	---
156	9C	VDP_OUTPUT_SEL	RW	I2C_GS_VPS_PDC_UTC.1	I2C_GS_VPS_PDC_UTC.0	GS_VPS_PDC_UTC_CB_CHANGE	WSS_CGMS_CB_CHANGE					00110000	30

# ADV7184

Table 104 provides a detailed description of the registers located in the User Sub Map.

**Table 104. User Sub Map Detailed Description**

User Sub Map		Bit Description	Bit					Comments	Notes					
Address	Register		7	6	5	4	3			2	1	0		
0x40	Interrupt Configuration 1	INTRQ_OP_SEL[1:0]. Interrupt Drive Level Select							0	0	Open drain			
										0	1		Drive low when active	
											1		0	Drive high when active
											1		1	Reserved
		MPU_STIM_INTRQ[1:0]. Manual Interrupt Set Mode								0			Manual interrupt mode disabled	
										1			Manual interrupt mode enabled	
		Reserved						x					Not used	
		MV_INTRQ_SEL[1:0]. Macrovision Interrupt Select			0	0							Reserved	
					0	1							Pseudo sync only	
					1	0							Color stripe only	
					1	1							Pseudo sync or color stripe	
		INTRQ_DUR_SEL[1:0]. Interrupt duration Select		0	0								3 XTAL periods	
	0		1							15 XTAL periods				
	1		0							63 XTAL periods				
	1		1							Active until cleared				
0x42	Interrupt Status 1 (Read Only)	SD_LOCK_Q								0	No change	These bits can be cleared or masked in Registers 0x43 and 0x44, respectively.		
											1		SD input has caused the decoder to go from an unlocked state to a locked state	
		SD_UNLOCK_Q									0		No change	
													1	SD input has caused the decoder to go from a locked state to an unlocked state
		Reserved									x			
		Reserved						x						
		Reserved					x							
		SD_FR_CHNG_Q			0								No Change	
					1								Denotes a change in the free-run status	
		MV_PS_CS_Q		0									No Change	
				1									Pseudo sync/color striping detected. See Reg 0x40 MV_INTRQ_SEL[1:0] for selection	
		Reserved		x										
0x43	Interrupt Clear 1 (Write Only)	SD_LOCK_CLR								0	Do not clear			
											1	Clears SD_LOCK_Q bit		
		SD_UNLOCK_CLR									0	Do not clear		
												1	Clears SD_UNLOCK_Q bit	
		Reserved									0	Not used		
		Reserved									0	Not used		
		Reserved					0					Not used		
		SD_FR_CHNG_CLR		0								Do not clear		
				1								Clears SD_FR_CHNG_Q bit		
		MV_PS_CS_CLR		0								Do not clear		
				1								Clears MV_PS_CS_Q bit		
		Reserved		x								Not used		
0x44	Interrupt Mask 1 (Read/Write)	SD_LOCK_MSKB								0	Masks SD_LOCK_Q bit			
											1	Unmasks SD_LOCK_Q bit		
		SD_UNLOCK_MSKB									0	Masks SD_UNLOCK_Q bit		
												1	Unmasks SD_UNLOCK_Q bit	
		Reserved									0	Not used		
		Reserved									0	Not used		
		Reserved					0					Not used		
		SD_FR_CHNG_MSKB		0								Masks SD_FR_CHNG_Q bit		
				1								Unmasks SD_FR_CHNG_Q bit		
		MV_PS_CS_MSKB		0								Masks MV_PS_CS_Q bit		
				1								Unmasks MV_PS_CS_Q bit		
		Reserved		x								Not used		

User Sub Map		Bit								Comments	Notes		
Address	Register	Bit Description	7	6	5	4	3	2	1			0	
0x45	Raw Status 2 (Read Only)	CCAPD								0	No CCAPD data detected – VBI system 2	These bits are status bits only. They <b>cannot</b> be cleared or masked. Register 0x46 is used for this purpose.	
										1	CCAPD data detected – VBI system 2		
		Reserved					x	x	x				
		EVEN_FIELD				0							Current SD Field is Odd Numbered
					1								Current SD Field is Even Numbered
		Reserved		x	x								
		MPU_STIM_INTRQ	0										MPU_STIM_INT = 0
	1									MPU_STIM_INT = 1			
0x46	Interrupt Status 2 (Read Only)	CCAPD_Q								0	Closed captioning not detected in the input video signal – VBI system 2	These bits can be cleared or masked by registers 0x47 and 0x48, respectively.  Note that interrupt in register 0x46 for the CCAP, Gemstar, CGMS and WSS data is using the Mode 1 data slicer.	
										1	Closed captioning data detected in the video input signal – VBI system 2		
		GEMD_Q								0	Gemstar data not detected in the input video signal– VBI system 2		
										1	Gemstar data detected in the input video signal– VBI system 2		
		Reserved					x	x					
		SD_FIELD_CHNGD_Q			0						SD signal has not changed Field from ODD to Even or Vice versa		
					1						SD signal has changed Field from ODD to Even or Vice versa		
		Reserved			x						Not used		
		Reserved		x							Not used		
		MPU_STIM_INTRQ_Q	0								Manual interrupt not Set		
	1								Manual interrupt Set				
0x47	Interrupt Clear 2 (Write Only)	CCAPD_CLR								0	Do not clear – VBI system 2	Note that interrupt in register 0x46 for the CCAP, Gemstar, CGMS and WSS data is using the Mode 1 data slicer.	
										1	Clears CCAPD_Q bit – VBI system 2		
		GEMD_CLR								0	Do not clear		
										1	Clears GEMD_Q bit		
		Reserved					x	x					
		SD_FIELD_CHNGD_CLR			0						Do not Clear		
					1						Clears SD_FIELD_CHNGD_Q bit		
Reserved			x						Not used				
Reserved		x							Not used				
MPU_STIM_INTRQ_CLR	0								Do not clear				
	1								Clears MPU_STIM_INTRQ_Q bit				
0x48	Interrupt Mask 2 (Read/Write)	CCAPD_MSKB								0	Masks CCAPD_Q bit – VBI system 2	Note that interrupt in register 0x46 for the CCAP, Gemstar, CGMS and WSS data is using the Mode 1 data slicer.	
										1	Unmasks CCAPD_Q bit – VBI system 2		
		GEMD_MSKB								0	Masks GEMD_Q bit – VBI system 2		
										1	Unmasks GEMD_Q bit – VBI system 2		
		Reserved					0	0			Not used		
		SD_FIELD_CHNGD_MSKB			0						Masks SD_FIELD_CHNGD_Q bit		
					1						Unmasks SD_FIELD_CHNGD_Q bit		
Reserved		0	0						Not used				
MPU_STIM_INTRQ_MSKB	0								Masks MPU_STIM_INTRQ_Q bit				
	1								Unmasks MPU_STIM_INTRQ_Q bit				
0x49	Raw Status 3 (Read Only)	SD_OP_50Hz. SD 60/50Hz frame rate at output								0	SD 60 Hz signal output	These bits are status bits only. They <b>cannot</b> be cleared or masked. Register 0x4A is used for this purpose.	
										1	SD 50 Hz signal output		
		SD_V_LOCK								0	SD vertical sync lock not established		
										1	SD vertical sync lock established		
		SD_H_LOCK							0		SD horizontal sync lock not established		
									1		SD horizontal sync lock established		
		Reserved					x				Not used		
		SCM_LOCK			0						SECAM lock not established		
					1						SECAM lock established		
Reserved			x						Not used				
Reserved		x							Not used				
Reserved		x							Not used				

# ADV7184

User Sub Map		Bit								Comments	Notes			
Address	Register	Bit Description	7	6	5	4	3	2	1			0		
0x4A	Interrupt Status 3 (Read Only)	SD_OP_CHNG_Q. SD 60/50 Hz frame rate at output									0	No Change in SD signal standard detected at the output	These bits can be cleared and masked by Registers 0x4B and 0x4C, respectively.	
												1		A Change in SD signal standard is detected at the output
		SD_V_LOCK_CHNG_Q										0		No change in SD vertical sync lock status
												1		SD vertical sync lock status has changed
		SD_H_LOCK_CHNG_Q										0		No change in SD horizontal sync lock status
												1		SD horizontal sync lock status has changed
		SD_AD_CHNG_Q. SD autodetect changed							x					No change in AD_RESULT[2:0] bits in Status Register 1
														AD_RESULT[2:0] bits in Status Register 1 have changed
		SCM_LOCK_CHNG_Q. SECAM Lock						0						No change in SECAM Lock status
								1						SECAM lock status has changed
		PAL_SW_LK_CHNG_Q				x								No change in PAL swinging burst lock status
														PAL swinging burst lock status has changed
Reserved				x							Not used			
Reserved				x							Not used			
0x4B	Interrupt Clear 3 (Write Only)	SD_OP_CHNG_CLR									0	Do not clear		
												1		Clears SD_OP_CHNG_Q bit
		SD_V_LOCK_CHNG_CLR										0		Do not clear
												1		Clears SD_V_LOCK_CHNG_Q bit
		SD_H_LOCK_CHNG_CLR										0		Do not clear
												1		Clears SD_H_LOCK_CHNG_Q bit
		SD_AD_CHNG_CLR										0		Do not clear
												1		Clears SD_AD_CHNG_Q bit
		SCM_LOCK_CHNG_CLR						0						Do not clear
								1						Clears SCM_LOCK_CHNG_Q bit
		PAL_SW_LK_CHNG_CLR					0							Do not clear
								1						Clears PAL_SW_LK_CHNG_Q bit
Reserved					x						Not used			
Reserved					x						Not used			
0x4C	Interrupt Mask 2 (Read/Write)	SD_OP_CHNG_MSKB									0	Masks SD_OP_CHNG_Q bit		
												1		Unmasks SD_OP_CHNG_Q bit
		SD_V_LOCK_CHNG_MSKB										0		Masks SD_V_LOCK_CHNG_Q bit
												1		Unmasks SD_V_LOCK_CHNG_Q bit
		SD_H_LOCK_CHNG_MSKB										0		Masks SD_H_LOCK_CHNG_Q bit
												1		Unmasks SD_H_LOCK_CHNG_Q bit
		SD_AD_CHNG_MSKB										0		Masks SD_AD_CHNG_Q bit
												1		Unmasks SD_AD_CHNG_Q bit
		SCM_LOCK_CHNG_MSKB						0						Masks SCM_LOCK_CHNG_Q bit
								1						Unmasks SCM_LOCK_CHNG_Q bit
		PAL_SW_LK_CHNG_MSKB						0						Masks PAL_SW_LK_CHNG_Q bit
								1						Unmasks PAL_SW_LK_CHNG_Q bit
Reserved						x					Not used			
Reserved						x					Not used			
0x4E	Interrupt Status 4 (Read Only)	VDP_CCAPD_Q									0	Closed captioning not detected	These bits can be cleared and masked by Registers 0x4F and 0x50, respectively.  Note that interrupt in register 0x4E for the CCAP, Gemstar, CGMS, WSS,VPS,PDC, UTC and VITC data is using the VDP data slicer.	
												1		Closed captioning detected
		Reserved										x		
			VDP_CGMS_WSS_CHNGD_Q. See 0x9C Bit 4 of User Sub Map to determine whether interrupt is issued for a change in detected data or for when data is detected regardless of content									0		CGMS/WSS data is not changed/not available
												1		CGMS/WSS data is changed/available
		Reserved										x		
VDP_GS_VPS_PDC_UTC_CHNG_Q. See 0x9C Bit 5 of User Sub Map to determine							0				Gemstar/PDC/VPS/UTC data is not changed/available			

User Sub Map			Bit								Comments	Notes		
Address	Register	Bit Description	7	6	5	4	3	2	1	0				
		whether interrupt is issued for a change in detected data or for when data is detected regardless of content				1						Gemstar/PDC/VPS/UTC data is changed/available		
		Reserved			x									
		VDP_VITC_Q		0								VITC data is not available in the VDP		
		Reserved		1								VITC data is available in the VDP		
		Reserved	x											
0x4F	Interrupt Clear 4 (Write Only)	VDP_CCAPD_CLR								0		Do not clear	Note that interrupt in register 0x4E for the CCAP, Gemstar, CGMS, WSS,VPS,PDC, UTC and VITC data is using the VDP data slicer.	
		Reserved								1		Clears VDP_CCAPD_Q		
		Reserved								x				
		VDP_CGMS_WSS_CHNGD_CLR							0					Do not clear
		Reserved							1					Clears VDP_CGMS_WSS_CHNGD_Q
		Reserved						x						
		VDP_GS_VPS_PDC_UTC_CHNG_CLR				0								Do not clear
		Reserved				1								Clears VDP_GS_VPS_PDC_UTC_CHNG_Q
	Reserved				x									
	VDP_VITC_CLR		0									Do not clear		
	Reserved		1									Clears VDP_VITC_Q		
	Reserved	x												
0x50	Interrupt Mask 4	VDP_CCAPD_MSKB								0		Masks VDP_CCAPD_Q	Note that interrupt in register 0x4E for the CCAP, Gemstar, CGMS, WSS,VPS,PDC, UTC and VITC data is using the VDP data slicer.	
		Reserved								1		Unmasks VDP_CCAP_D_Q		
		Reserved								x				
		VDP_CGMS_WSS_CHNGD_MSKB							0					Masks VDP_CGMS_WSS_CHNGD_Q
		Reserved							1					Unmasks VDP_CGMS_WSS_CHNGD_Q
		Reserved						x						
		VDP_GS_VPS_PDC_UTC_CHNG_MSKB				0								Masks VDP_GS_VPS_PDC_UTC_CHNG_Q
		Reserved				1								Unmasks VDP_GS_VPS_PDC_UTC_CHNG_Q
	Reserved				x									
	VDP_VITC_MSKB		0									Masks VDP_VITC_Q		
	Reserved		1									Unmasks VDP_VITC_Q		
	Reserved	x												
0x60	VDP_Config_1	VDP_TTXXT_TYPE_MAN[1:0]								0	0	PAL: Teletext-ITU-BT.653-625/50-A NTSC: Reserved		
											0	1	PAL: Teletext-ITU-BT.653-625/50-B (WST) NTSC: Teletext-ITU-BT.653-525/60-B	
											1	0	PAL: Teletext-ITU-BT.653-625/50-C NTSC: Teletext-ITU-BT.653-525/60-C OR EIA516 (NABTS)	
											1	1	PAL: Teletext-ITU-BT.653-625/50-D NTSC: Teletext-ITU-BT.653-525/60-D	
		VDP_TTXXT_TYPE_MAN_ENABLE								0			User programming of teletext type disabled	
										1			User programming of teletext type enabled	
		WST_PKT_DECOD_DISABLE							0				Enable hamming decoding of WST packets	
		Reserved						1					Disable hamming decoding of WST packets	
	Reserved		1	0	0	0								
0x61	VDP_Config_2	Reserved					x	x	0	0				
		AUTO_DETECT_GS_TYPE				0							Disable autodetection of Gemstar type	
		Reserved				1							Enable autodetection of Gemstar type	
	Reserved		0	0	0									
0x62	VDP_ADF_Config_1	ADF_DID[4:0]				1	0	1	0	1		User specified DID sent in the ancillary data stream with VDP decoded data		
		ADF_MODE[1:0]		0	0							Nibble mode		
		Reserved		0	1								Byte mode, no code restrictions	

# ADV7184

User Sub Map		Bit								Comments	Notes		
Address	Register	Bit Description	7	6	5	4	3	2	1			0	
				1	0						Byte mode with 0x00 and 0xFF prevented		
				1	1						Reserved		
		ADF_ENABLE	0										Disable insertion of VBI decoded data into ancillary 656 stream
			1										Enable insertion of VBI decoded data into ancillary 656 stream
0x63	VDP_ADF_Config_2	ADF_SDID[5:0]			1	0	1	0	1	0	User-specified SDID sent in the ancillary data stream with VDP decoded data		
		Reserved		x									
		DUPLICATE_ADF	0										Ancillary data packet is spread across the Y and C data streams
			1								Ancillary data packet is duplicated on the Y and C data streams		
			0										
0x64	VDP_LINE_00E	VBI_DATA_P318[3:0]					0	0	0	0	Sets VBI standard to be decoded from line 318 (PAL). NTSC – N/A		
		Reserved		0	0	0							
		MAN_LINE_PGM	0										Decode default standards on the lines indicated in Table 64.
			1								Manually program the VBI standard to be decoded on each line. See Table 65	If set to 1, all VBI_DATA_Px_Ny bits must set as desired.	
0x65	VDP_LINE_00F	VBI_DATA_P319_N286[3:0]					0	0	0	0	Sets VBI standard to be decoded from line 319 (PAL), 286 (NTSC)	MAN_LINE_PGM must be set to 1 for these bits to be effective	
		VBI_DATA_P6_N23[3:0]	0	0	0	0					Sets VBI standard to be decoded from line 6 (PAL), 23 (NTSC)		
0x66	VDP_LINE_010	VBI_DATA_P320_N287[3:0]					0	0	0	0	Sets VBI standard to be decoded from line 320 (PAL), 287 (NTSC)	MAN_LINE_PGM must be set to 1 for these bits to be effective	
		VBI_DATA_P7_N24[3:0]	0	0	0	0					Sets VBI standard to be decoded from line 7 (PAL), 24 (NTSC)		
0x67	VDP_LINE_011	VBI_DATA_P321_N288[3:0]					0	0	0	0	Sets VBI standard to be decoded from line 321 (PAL), 288 (NTSC)	MAN_LINE_PGM must be set to 1 for these bits to be effective	
		VBI_DATA_P8_N25[3:0]	0	0	0	0					Sets VBI standard to be decoded from line 8 (PAL), 25 (NTSC)		
0x68	VDP_LINE_012	VBI_DATA_P322[3:0]					0	0	0	0	Sets VBI standard to be decoded from line 322 (PAL), NTSC – N/A	MAN_LINE_PGM must be set to 1 for these bits to be effective	
		VBI_DATA_P9[3:0]	0	0	0	0					Sets VBI standard to be decoded from line 9 (PAL), NTSC – N/A		
0x69	VDP_LINE_013	VBI_DATA_P323[3:0]					0	0	0	0	Sets VBI standard to be decoded from line 323 (PAL), NTSC – N/A	MAN_LINE_PGM must be set to 1 for these bits to be effective	
		VBI_DATA_P10[3:0]	0	0	0	0					Sets VBI standard to be decoded from line 10 (PAL), NTSC – N/A		
0x6A	VDP_LINE_014	VBI_DATA_P324_N272[3:0]					0	0	0	0	Sets VBI standard to be decoded from line 324 (PAL), 272 (NTSC)	MAN_LINE_PGM must be set to 1 for these bits to be effective	
		VBI_DATA_P11[3:0]	0	0	0	0					Sets VBI standard to be decoded from line 11 (PAL), NTSC – N/A		
0x6B	VDP_LINE_015	VBI_DATA_P325_N273[3:0]					0	0	0	0	Sets VBI standard to be decoded from line 325 (PAL), 273 (NTSC)	MAN_LINE_PGM must be set to 1 for these bits to be effective	
		VBI_DATA_P12_N10[3:0]	0	0	0	0					Sets VBI standard to be decoded from line 12 (PAL), 10 (NTSC)		
0x6C	VDP_LINE_016	VBI_DATA_P326_N274[3:0]					0	0	0	0	Sets VBI standard to be decoded from line 326 (PAL), 274 (NTSC)	MAN_LINE_PGM must be set to 1 for these bits to be effective	
		VBI_DATA_P13_N11[3:0]	0	0	0	0					Sets VBI standard to be decoded from line 13 (PAL), 11 (NTSC)		
0x6D	VDP_LINE_017	VBI_DATA_P327_N275[3:0]					0	0	0	0	Sets VBI standard to be decoded from line 327 (PAL), 275 (NTSC)	MAN_LINE_PGM must be set to 1 for these bits to be effective	
		VBI_DATA_P14_N12[3:0]	0	0	0	0					Sets VBI standard to be decoded from line 14 (PAL), 12 (NTSC)		
0x6E	VDP_LINE_018	VBI_DATA_P328_N276[3:0]					0	0	0	0	Sets VBI standard to be decoded from line 328 (PAL), 276 (NTSC)	MAN_LINE_PGM must be set to 1 for these bits to be effective	
		VBI_DATA_P15_N13[3:0]	0	0	0	0					Sets VBI standard to be decoded from line 15 (PAL), 13 (NTSC)		
0x6F	VDP_LINE_019	VBI_DATA_P329_N277[3:0]					0	0	0	0	Sets VBI standard to be decoded from line 329 (PAL), 277 (NTSC)	MAN_LINE_PGM must be set to 1 for these bits to be effective	
		VBI_DATA_P16_N14[3:0]	0	0	0	0					Sets VBI standard to be decoded from line 16 (PAL), 14 (NTSC)		
0x70	VDP_LINE_01A	VBI_DATA_P330_N278[3:0]					0	0	0	0	Sets VBI standard to be decoded from line 330 (PAL), 278 (NTSC)	MAN_LINE_PGM must be set to 1 for these bits to be effective	

User Sub Map			Bit								Comments	Notes		
Address	Register	Bit Description	7	6	5	4	3	2	1	0				
		VBI_DATA_P17_N15[3:0]	0	0	0	0					Sets VBI standard to be decoded from line 17 (PAL), 15 (NTSC)	effective		
0x71	VDP_LINE_01B	VBI_DATA_P331_N279[3:0]					0	0	0	0	Sets VBI standard to be decoded from line 331 (PAL), 279 (NTSC)	MAN_LINE_PGM must be set to 1 for these bits to be effective		
		VBI_DATA_P18_N16[3:0]	0	0	0	0					Sets VBI standard to be decoded from line 18 (PAL), 16 (NTSC)			
0x72	VDP_LINE_01C	VBI_DATA_P332_N280[3:0]					0	0	0	0	Sets VBI standard to be decoded from line 332 (PAL), 280 (NTSC)	MAN_LINE_PGM must be set to 1 for these bits to be effective		
		VBI_DATA_P19_N17[3:0]	0	0	0	0					Sets VBI standard to be decoded from line 19 (PAL), 17 (NTSC)			
0x73	VDP_LINE_01D	VBI_DATA_P333_N281[3:0]					0	0	0	0	Sets VBI standard to be decoded from line 333 (PAL), 281 (NTSC)	MAN_LINE_PGM must be set to 1 for these bits to be effective		
		VBI_DATA_P20_N18[3:0]	0	0	0	0					Sets VBI standard to be decoded from line 20 (PAL), 18 (NTSC)			
0x74	VDP_LINE_01E	VBI_DATA_P334_N282[3:0]					0	0	0	0	Sets VBI standard to be decoded from line 334 (PAL), 282 (NTSC)	MAN_LINE_PGM must be set to 1 for these bits to be effective		
		VBI_DATA_P21_N19[3:0]	0	0	0	0					Sets VBI standard to be decoded from line 21 (PAL), 19 (NTSC)			
0x75	VDP_LINE_01F	VBI_DATA_P335_N283[3:0]					0	0	0	0	Sets VBI standard to be decoded from line 335 (PAL), 283 (NTSC)	MAN_LINE_PGM must be set to 1 for these bits to be effective		
		VBI_DATA_P22_N20[3:0]	0	0	0	0					Sets VBI standard to be decoded from line 22 (PAL), 20 (NTSC)			
0x76	VDP_LINE_020	VBI_DATA_P336_N284[3:0]					0	0	0	0	Sets VBI standard to be decoded from line 336 (PAL), 284 (NTSC)	MAN_LINE_PGM must be set to 1 for these bits to be effective		
		VBI_DATA_P23_N21[3:0]	0	0	0	0					Sets VBI standard to be decoded from line 23 (PAL), 21 (NTSC)			
0x77	VDP_LINE_021	VBI_DATA_P337_N285[3:0]					0	0	0	0	Sets VBI standard to be decoded from line 337 (PAL), 285 (NTSC)	MAN_LINE_PGM must be set to 1 for these bits to be effective		
		VBI_DATA_P24_N22[3:0]	0	0	0	0					Sets VBI standard to be decoded from line 24 (PAL), 22 (NTSC)			
0x78	VDP_STATUS (Read Only)	CC_AVL								0	Closed captioning not detected	CC_CLEAR resets the CC_AVL bit		
										1	Closed captioning detected			
		CC_EVEN_FIELD								0	Closed captioning decoded from odd field			
										1	Closed captioning decoded from even field			
		CGMS_WSS_AVL								0	CGMS/WSS not detected		CGMS_WSS_CLEAR resets the CGMS_WSS_AVL bit	
										1	CGMS/WSS detected			
		Reserved								0				
		GS_PDC_VPS_UTC_AVL					0						VPS not detected	GS_PDC_VPS_UTC_CLEAR resets the GS_PDC_VPS_UTC_AVL bit
							1						VPS detected	
		GS_DATA_TYPE				0							Gemstar 1x detected	
				1						Gemstar 2x detected				
VITC_AVL			0								VITC not detected	VITC_CLEAR resets the VITC_AVL bit		
			1								VITC detected			
TTXT_AVL			0								Teletext not detected			
			1								Teletext detected			
0x78	VDP_STATUS_CLEAR (Write Only)	CC_CLEAR								0	Do not re-initialize the CCAP registers	This is a self-clearing bit		
										1	Re-initializes the CCAP readback registers			
		Reserved									0			
		CGMS_WSS_CLEAR								0		Do not re-initialize the CGMS/WSS registers	This is a self-clearing bit	
										1		Re-initializes the CGMS/WSS readback registers		
		Reserved									0			
		GS_PDC_VPS_UTC_CLEAR					0					Do not re-initialize the GS/PDC/VPS/UTC registers	This is a self-clearing bit	
							1					Refreshes the GS/PDC/VPS/UTC readback registers		
		Reserved									0			
		VITC_CLEAR				0							Do not re-initialize the VITC registers	This is a self-clearing bit
					1						Re-initializes the VITC readback registers			
Reserved									0					

# ADV7184

User Sub Map			Bit								Comments	Notes
Address	Register	Bit Description	7	6	5	4	3	2	1	0		
0x79	VDP_CCAP_DATA_0 (Read Only)	CCAP_BYTE_1[7:0]	x	x	x	x	x	x	x	x	Decoded Byte 1 of CCAP	
0x7A	VDP_CCAP_DATA_1 (Read Only)	CCAP_BYTE_2[7:0]	x	x	x	x	x	x	x	x	Decoded Byte 2 of CCAP	
0x7D	VDP_CGMS_WSS_DATA_0 (Read Only)	CGMS_CRC[5:2]					x	x	x	x	Decoded CRC sequence for CGMS	
		Reserved	0	0	0	0						
0x7E	VDP_CGMS_WSS_DATA_1 (Read Only)	CGMS_WSS[13:8]			x	x	x	x	x	x	Decoded CGMS/WSS data	
		CGMS_CRC[1:0]	x	x							Decoded CRC sequence for CGMS	
0x7F	VDP_CGMS_WSS_DATA_2 (Read Only)	CGMS_WSS[7:0]	x	x	x	x	x	x	x	x	Decoded CGMS/WSS data	
0x84	VDP_GS_VPS_PDC_UTC_0 (Read Only)	GS_VPS_PDC_UTC_BYTE_0[7:0]	x	x	x	x	x	x	x	x	Decoded Gemstar/VPS/PDC/UTC data	
0x85	VDP_GS_VPS_PDC_UTC_1 (Read Only)	GS_VPS_PDC_UTC_BYTE_1[7:0]	x	x	x	x	x	x	x	x	Decoded Gemstar/VPS/PDC/UTC data	
0x86	VDP_GS_VPS_PDC_UTC_2 (Read Only)	GS_VPS_PDC_UTC_BYTE_2[7:0]	x	x	x	x	x	x	x	x	Decoded Gemstar/VPS/PDC/UTC data	
0x87	VDP_GS_VPS_PDC_UTC_3 (Read Only)	GS_VPS_PDC_UTC_BYTE_3[7:0]	x	x	x	x	x	x	x	x	Decoded Gemstar/VPS/PDC/UTC data	
0x88	VDP_VPS_PDC_UTC_4 (Read Only)	VPS_PDC_UTC_BYTE_4[7:0]	x	x	x	x	x	x	x	x	Decoded VPS/PDC/UTC data	
0x89	VDP_VPS_PDC_UTC_5 (Read Only)	VPS_PDC_UTC_BYTE_5[7:0]	x	x	x	x	x	x	x	x	Decoded VPS/PDC/UTC data	
0x8A	VDP_VPS_PDC_UTC_6 (Read Only)	VPS_PDC_UTC_BYTE_6[7:0]	x	x	x	x	x	x	x	x	Decoded VPS/PDC/UTC data	
0x8B	VDP_VPS_PDC_UTC_7 (Read Only)	VPS_PDC_UTC_BYTE_7[7:0]	x	x	x	x	x	x	x	x	Decoded VPS/PDC/UTC data	
0x8C	VDP_VPS_PDC_UTC_8 (Read Only)	VPS_PDC_UTC_BYTE_8[7:0]	x	x	x	x	x	x	x	x	Decoded VPS/PDC/UTC data	
0x8D	VDP_VPS_PDC_UTC_9 (Read Only)	VPS_PDC_UTC_BYTE_9[7:0]	x	x	x	x	x	x	x	x	Decoded VPS/PDC/UTC data	
0x8E	VDP_VPS_PDC_UTC_10 (Read Only)	VPS_PDC_UTC_BYTE_10[7:0]	x	x	x	x	x	x	x	x	Decoded VPS/PDC/UTC data	
0x8F	VDP_VPS_PDC_UTC_11 (Read Only)	VPS_PDC_UTC_BYTE_11[7:0]	x	x	x	x	x	x	x	x	Decoded VPS/PDC/UTC data	
0x90	VDP_VPS_PDC_UTC_12 (Read Only)	VPS_PDC_UTC_BYTE_12[7:0]	x	x	x	x	x	x	x	x	Decoded VPS/PDC/UTC data	
0x92	VDP_VITC_DATA_0 (Read Only)	VITC_DATA_0[7:0]	x	x	x	x	x	x	x	x	Decoded VITC data	
0x93	VDP_VITC_DATA_1 (Read Only)	VITC_DATA_1[7:0]	x	x	x	x	x	x	x	x	Decoded VITC data	
0x94	VDP_VITC_DATA_2 (Read Only)	VITC_DATA_2[7:0]	x	x	x	x	x	x	x	x	Decoded VITC data	
0x95	VDP_VITC_DATA_3 (Read Only)	VITC_DATA_3[7:0]	x	x	x	x	x	x	x	x	Decoded VITC data	
0x96	VDP_VITC_DATA_4 (Read Only)	VITC_DATA_4[7:0]	x	x	x	x	x	x	x	x	Decoded VITC data	
0x97	VDP_VITC_DATA_5 (Read Only)	VITC_DATA_5[7:0]	x	x	x	x	x	x	x	x	Decoded VITC data	
0x98	VDP_VITC_DATA_6 (Read Only)	VITC_DATA_6[7:0]	x	x	x	x	x	x	x	x	Decoded VITC data	
0x99	VDP_VITC_DATA_7 (Read Only)	VITC_DATA_7[7:0]	x	x	x	x	x	x	x	x	Decoded VITC data	
0x9A	VDP_VITC_DATA_8 (Read Only)	VITC_DATA_8[7:0]	x	x	x	x	x	x	x	x	Decoded VITC data	
0x9B	VDP_VITC_CALC_CRC (Read Only)	VITC_CRC[7:0]	x	x	x	x	x	x	x	x	Decoded VITC CRC data	
0x9C	VDP_OUTPUT_SEL	Reserved					0	0	0	0		
		WSS_CGMS_CB_CHANGE				0					Disable content-based updating of CGMS and WSS data	The AVAILABLE bit shows the availability of data only when its content has changed.
					1					Enable content-based updating of CGMS and WSS data		
		GS_VPS_PDC_UTC_CB_CHANGE			0						Disable content-based updating of Gemstar, VPS, PDC and UTC data	Standard expected to be decoded
					1					Enable content-based updating of Gemstar, VPS, PDC and UTC data		
		12C_GS_VPS_PDC_UTC[1:0]	0	0						Gemstar 1x/2x		
			0	1						VPS		
	1	0						PDC				
	1	1						UTC				

## I<sup>2</sup>C PROGRAMMING EXAMPLES

Note: These scripts are applicable to a system with the analog inputs arranged as shown in Figure 50. The input selection registers change in accordance with how the PCB is laid out.

### MODE 1 CVBS INPUT

Composite video on AIN10. All standards are supported through autodetect, 8-bit, 4:2:2, ITU-R BT.656 output on P15 to P8.

**Table 105. Mode 1 CVBS Input**

Register Address	Register Value	Notes
0x00	0x0E	CVBS on AIN 10.
0x17	0x41	Set CSFM to SH1.
0x19	0xFA	Split filter control.
0x1D	0x47	Enable 28.63636 MHz crystal mode.
0x3A	0x17	Power down ADC1, ADC2 and ADC3.
0x3B	0x71	Recommended setting.
0x3D	0xA2	MWE enable manual window, color kill threshold to 2.
0x3E	0x6A	BLM optimization.
0x3F	0xA0	BGB optimization
0xF3	0x01	Enable antialias filter on ADC0.
0xF9	0x03	Set maximum v lock range.
0x0E	0x80	Recommended setting.
0x52	0x46	Recommended setting.
0x54	0x00	Recommended setting.
0x7F	0xFF	Recommended setting.
0x81	0x30	Recommended setting.
0x90	0xC9	Recommended setting.
0x91	0x40	Recommended setting.
0x92	0x3C	Recommended setting.
0x93	0xCA	Recommended setting.
0x94	0xD5	Recommended setting.
0xB1	0xFF	Recommended setting.
0xB6	0x08	Recommended setting.
0xC0	0x9A	Recommended setting.
0xCF	0x50	Recommended setting.
0xD0	0x4E	Recommended setting.
0xD1	0xB9	Recommended setting.
0xD6	0xDD	Recommended setting.
0xD7	0xE2	Recommended setting.
0xE5	0x51	Recommended setting.
0x0E	0x00	Recommended setting.

# ADV7184

## MODE 2 S-VIDEO INPUT

Y on AIN2 and C on AIN3. All standards are supported through autodetect, 8-bit, ITU-R BT.656 output on P15 to P8.

Table 106. Mode 2 S-Video Input

Register Address	Register Value	Notes
0x1D	0x47	Enable 28.63636 MHz crystal mode.
0x3A	0x13	Power down ADC2 and ADC3.
0x3B	0x71	Recommended setting.
0x3D	0xA2	MWE enable manual window, color kill threshold to 2.
0x3E	0x6A	BLM optimization.
0x3F	0xA0	BGB optimization.
0x69	0x03	Set SDM_SEL to 03 for YC/CVBS auto AIN11, AIN12.
0xC3	0x32	Manually mux Y signal on AIN2 to ADC0 and C signal on AIN3 to ADC1.
0xC4	0xFF	Manual mux enable.
0xF3	0x03	Enable anti-alias filter on ADC0 and ADC1.
0xF9	0x03	Set maximum v lock range.
0x0E	0x80	Recommended setting.
0x52	0x46	Recommended setting.
0x54	0x00	Recommended setting.
0x7F	0xFF	Recommended setting.
0x81	0x30	Recommended setting.
0x90	0xC9	Recommended setting.
0x91	0x40	Recommended setting.
0x92	0x3C	Recommended setting.
0x93	0xCA	Recommended setting.
0x94	0xD5	Recommended setting.
0xB1	0xFF	Recommended setting.
0xB6	0x08	Recommended setting.
0xC0	0x9A	Recommended setting.
0xCF	0x50	Recommended setting.
0xD0	0x4E	Recommended setting.
0xD1	0xB9	Recommended setting.
0xD6	0xDD	Recommended setting.
0xD7	0xE2	Recommended setting.
0xE5	0x51	Recommended setting.
0x0E	0x00	Recommended setting.

**MODE 3 525I/625I YPRPB INPUT**

Y on AIN6, Pr on AIN4, and Pb on AIN5. All standards are supported through autodetect, 8-bit, ITU-R BT.656 output on P15 to P8.

**Table 107. Mode 3 YPrPb Input 525i/625i**

Register Address	Register Value	Notes
0x8D	0x83	Recommended setting.
0x00	0x09	Set YPrPb mode. Note: Writes below to registers 0xC3 and 0xC4, overrides INSEL YPrPb setting.
0x1D	0x47	Enable 28.63636 MHz crystal mode.
0x27	0x98	Swap Cr and Cb, Y/C delay correction.
0x3A	0x11	Power down ADC3.
0x3B	0x71	Recommended setting.
0x3D	0xA2	MWE enable manual window, color kill threshold to 2.
0x3E	0x6A	BLM optimization.
0x3F	0xA0	BGB optimization.
0xB4	0xF9	Recommended setting.
0xB5	0x00	Recommended setting.
0xC3	0x46	Manually mux Y signal on AIN6 to ADC0, Pr signal on AIN4 to ADC1.
0xC4	0xB5	Manual mux enable, Pb signal on AIN5 to ADC2.
0xF3	0x07	Enable anti-alias filter on ADC0, ADC1 and ADC2.
0xF9	0x03	Set maximum v lock range.
0x0E	0x80	Recommended setting.
0x52	0x46	Recommended setting.
0x54	0x00	Recommended setting.
0x7F	0xFF	Recommended setting.
0x81	0x30	Recommended setting.
0x90	0xC9	Recommended setting.
0x91	0x40	Recommended setting.
0x92	0x3C	Recommended setting.
0x93	0xCA	Recommended setting.
0x94	0xD5	Recommended setting.
0x7E	0x73	Recommended setting.
0xB1	0xFF	Recommended setting.
0xB6	0x08	Recommended setting.
0xC0	0x9A	Recommended setting.
0xCF	0x50	Recommended setting.
0xD0	0x4E	Recommended setting.
0xD1	0xB9	Recommended setting.
0xD6	0xDD	Recommended setting.
0xE5	0x51	Recommended setting.
0x0E	0x00	Recommended setting.

# ADV7184

## MODE 4 SCART—S-VIDEO OR CVBS AUTODETECT

Y/CVBS Input on AIN11, C INPUT on AIN12, 8-bit, ITU-R BT.656 output on P15 to P8.

**Table 108. Mode 4 SCART CVBS/S-Video Autodetect on AIN 11/ AIN12**

Register Address	Register Value	Notes
0x1D	0x47	Enable 28.63636 MHz crystal mode.
0x3A	0x13	Power down ADC2 and ADC3.
0x3B	0x71	Recommended Setting
0x3D	0xA2	MWE enable manual window, color kill threshold to 2.
0x3E	0x6A	BLM optimization.
0x3F	0xA0	BGB optimization.
0x69	0x03	Set SDM_SEL to 03 for YC/CVBS auto AIN11, AIN12.
0xF3	0x03	Enable anti-alias filter on ADC0 and ADC1.
0xF9	0x03	Set maximum v lock range
0x0E	0x80	Recommended setting.
0x52	0x46	Recommended setting.
0x54	0x00	Recommended setting.
0x7F	0xFF	Recommended setting.
0x81	0x30	Recommended setting.
0x90	0xC9	Recommended setting.
0x91	0x40	Recommended setting.
0x92	0x3C	Recommended setting.
0x93	0xCA	Recommended setting.
0x94	0xD5	Recommended setting.
0xB1	0xFF	Recommended setting.
0xB6	0x08	Recommended setting.
0xC0	0x9A	Recommended setting.
0xCF	0x50	Recommended setting.
0xD0	0x4E	Recommended setting.
0xD1	0xB9	Recommended setting.
0xD6	0xDD	Recommended setting.
0xD7	0xE2	Recommended setting.
0xE5	0x51	Recommended setting.
0x0E	0x00	Recommended setting.

**MODE 5 SCART FAST BLANK—CVBS AND RGB**

CVBS Input on AIN11, B INPUT on AIN7, R INPUT on AIN8, G INPUT on AIN9; 8-bit, ITU-R BT.656 output on P15 to P8.

**Table 109. Mode 5 SCART CVBS/S-Video Autodetect on AIN 11/ AIN12**

Register Address	Register Value	Notes
0x00	0x0F	CVBS on AIN11.
0x17	0x41	Set CSFM to SH1.
0x19	0xFA	Split filter control.
0x1D	0x47	Enable 28.63636 MHz crystal mode.
0x3A	0x10	Power up all four ADCs.
0x3B	0x71	Recommended setting.
0x3D	0xA2	MWE enable manual window, color kill threshold to 2.
0x3E	0x6A	BLM optimization.
0x3F	0xA0	BGB optimization.
0x4D	0xEE	Disable CTI
0x67	0x01	Format 422.
0x73	0xD0	Manual gain channels A, B, C.
0x74	0x04	Manual gain channels A, B, C.
0x75	0x01	Manual gain channels A, B, C.
0x76	0x00	Manual gain channels A, B, C.
0x77	0x04	Manual offsets A to 64d, B and C to 512d.
0x78	0x08	Manual offsets A to 64d, B and C to 512d.
0x79	0x02	Manual offsets A to 64d, B and C to 512d.
0x7A	0x00	Manual offsets A to 64d, B and C to 512d.
0xC5	0x00	Recommended write.
0xED	0x12	Enable dynamic fast blank mode.
0xF3	0x0F	Enable anti-alias filter on all ADCs.
0xF9	0x03	Set maximum v lock range.
0x0E	0x80	Recommended setting.
0x49	0x01	Recommended setting.
0x52	0x46	Recommended setting.
0x54	0x00	Recommended setting.
0x7F	0xFF	Recommended setting.
0x81	0x30	Recommended setting.
0x90	0xC9	Recommended setting.
0x91	0x40	Recommended setting.
0x92	0x3C	Recommended setting.
0x93	0xCA	Recommended setting.
0x94	0xD5	Recommended setting.
0xB1	0xFF	Recommended setting.
0xB6	0x08	Recommended setting.
0xC0	0x9A	Recommended setting.
0xCF	0x50	Recommended setting.
0xD0	0x4E	Recommended setting.
0xD1	0xB9	Recommended setting.
0xD6	0xDD	Recommended setting.
0xD7	0xE2	Recommended setting.
0xE5	0x51	Recommended setting.
0x0E	0x00	Recommended setting.

# ADV7184

## MODE 6 SCART RGB INPUT (STATIC FAST BLANK)—CVBS AND RGB

CVBS Input on AIN11, B INPUT on AIN7, R INPUT on AIN8, G INPUT on AIN9, 8-bit, ITU-R BT.656 output on P15 to P8.

Table 110. Mode 6 SCART CVBS/S-Video Autodetect on AIN 11/ AIN12

Register Address	Register Value	Notes
0x00	0x0F	CVBS on AIN11.
0x1D	0x47	Enable 28.63636 MHz crystal mode.
0x3A	0x10	Power up all four ADCs.
0x3B	0x71	Recommended setting.
0x3D	0xA2	MWE enable manual window, color kill threshold to 2.
0x3E	0x6A	BLM optimization.
0x3F	0xA0	BGB optimization.
0x4D	0xEE	Disable CTI.
0x67	0x01	Format 422.
0x73	0xD0	Manual gain channels A, B, C.
0x74	0x04	Manual gain channels A, B, C.
0x75	0x01	Manual gain channels A, B, C.
0x76	0x00	Manual gain channels A, B, C.
0x77	0x04	Manual offsets A to 64d, B and C to 512d.
0x78	0x08	Manual offsets A to 64d, B and C to 512d.
0x79	0x02	Manual offsets A to 64d, B and C to 512d.
0x7A	0x00	Manual offsets A to 64d, B and C to 512d.
0x93	0x78	Clamp optimization
0x94	0x23	Clamp optimization
0x95	0x11	Clamp optimization
0x96	0xC0	Clamp optimization
0xC5	0x00	Recommended write.
0xED	0xC4	Enable static switching mode and select RGB input.
0xF3	0x0F	Enable anti-alias filter on all ADCs.
0xF9	0x03	Set maximum v lock range.
0x0E	0x80	Recommended setting.
0x52	0x46	Recommended setting.
0x54	0x00	Recommended setting.
0x7F	0xFF	Recommended setting.
0x81	0x30	Recommended setting.
0x90	0xC9	Recommended setting.
0x91	0x40	Recommended setting.
0x92	0x3C	Recommended setting.
0x93	0xCA	Recommended setting.
0x94	0xD5	Recommended setting.
0xB1	0xFF	Recommended setting.
0xB6	0x08	Recommended setting.
0xC0	0x9A	Recommended setting.
0xCF	0x50	Recommended setting.
0xD0	0x4E	Recommended setting.
0xD1	0xB9	Recommended setting.
0xD6	0xDD	Recommended setting.
0xD7	0xE2	Recommended setting.
0xE5	0x51	Recommended setting.
0x0E	0x00	Recommended setting.

## PCB LAYOUT RECOMMENDATIONS

The ADV7184 is a high precision, high speed mixed-signal device. To achieve the maximum performance from the part, it is important to have a well laid out PCB board. The following is a guide for designing a board using the ADV7184.

### ANALOG INTERFACE INPUTS

Care should be taken when routing the inputs on the PCB. Track lengths should be kept to a minimum, and  $75\ \Omega$  trace impedances should be used when possible. Trace impedances other than  $75\ \Omega$  increase the chance of reflections.

### POWER SUPPLY DECOUPLING

It is recommended to decouple each power supply pin with  $0.1\ \mu\text{F}$  and  $10\ \text{nF}$  capacitors. The fundamental idea is to have a decoupling capacitor within about  $0.5\ \text{cm}$  of each power pin. Also, avoid placing the capacitor on the opposite side of the PCB board from the ADV7184, as doing so interposes resistive vias in the path. The decoupling capacitors should be located between the power plane and the power pin. Current should flow from the power plane to the capacitor to the power pin. Do not make the power connection between the capacitor and the power pin. Placing a via underneath the  $100\ \text{nF}$  capacitor pads, down to the power plane, is generally the best approach (see Figure 47).

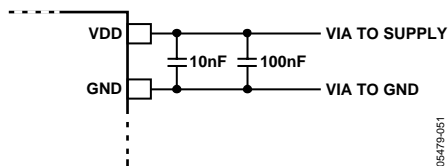

Figure 47. Recommended Power Supply Decoupling

It is particularly important to maintain low noise and good stability of PVDD. Careful attention must be paid to regulation, filtering, and decoupling. It is highly desirable to provide separate regulated supplies for each of the analog circuitry groups (AVDD, DVDD, DVDDIO, and PVDD).

Some graphic controllers use substantially different levels of power when active (during active picture time) and when idle (during horizontal and vertical sync periods). This can result in a measurable change in the voltage supplied to the analog supply regulator, which can, in turn, produce changes in the regulated analog supply voltage. This can be mitigated by regulating the analog supply, or at least PVDD, from a different, cleaner power source, for example, from a  $12\ \text{V}$  supply.

It is also recommended to use a single ground plane for the entire board. This ground plane should have a space between the analog and digital sections of the PCB (see Figure 48).

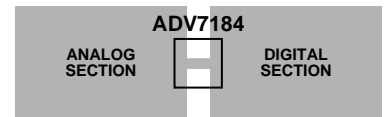

Figure 48. PCB Ground Layout

Experience has repeatedly shown that the noise performance is the same or better with a single ground plane. Using multiple ground planes can be detrimental because each separate ground plane is smaller, and long ground loops can result.

In some cases, using separate ground planes is unavoidable. For those cases, it is recommended to place a single ground plane under the ADV7184. The location of the split should be under the ADV7184. For this case, it is even more important to place components wisely because the current loops are much longer (current takes the path of least resistance). An example of a current loop: power plane to ADV7184 to digital output trace to digital data receiver to digital ground plane to analog ground plane.

### PLL

Place the PLL loop filter components as close as possible to the ELPF pin. Do not place any digital or other high frequency traces near these components. Use the values suggested in Figure 50 with tolerances of 10% or less.

### DIGITAL OUTPUTS (BOTH DATA AND CLOCKS)

Try to minimize the trace length that the digital outputs have to drive. Longer traces have higher capacitance, which requires more current, which causes more internal digital noise. Shorter traces reduce the possibility of reflections.

Adding a  $30\ \Omega$  to  $50\ \Omega$  series resistor can suppress reflections, reduce EMI, and reduce the current spikes inside the ADV7184. If series resistors are used, place them as close as possible to the ADV7184 pins. However, try not to add vias or extra length to the output trace to make the resistors closer.

If possible, limit the capacitance that each of the digital outputs drives to less than  $15\ \text{pF}$ . This can easily be accomplished by keeping traces short and by connecting the outputs to only one device. Loading the outputs with excessive capacitance increases the current transients inside the ADV7184, creating more digital noise on its power supplies.

# ADV7184

## DIGITAL INPUTS

The digital inputs on the ADV7184 are designed to work with 3.3 V signals, and are not tolerant of 5 V signals. Extra components are needed if 5 V logic signals are required to be applied to the decoder.

## XTAL AND LOAD CAPACITOR VALUES SELECTION

Figure 49 shows an example reference clock circuit for the ADV7184. Special care must be taken when using a crystal circuit to generate the reference clock for the ADV7184. Small variations in reference clock frequency may cause autodetection issues and impair the ADV7184 performance.

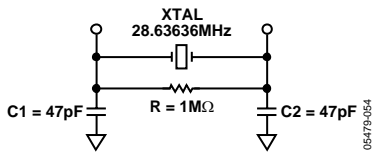

Figure 49. Crystal Circuit

Use the following guidelines to ensure correct operation:

- Use the correct, 28.63636 MHz, frequency crystal. Tolerance should be 50 ppm or better.
- User a parallel-resonant crystal.
- Know the  $C_{load}$  for the crystal part selected. The values of the C1 and C2 capacitors must be calculated using this  $C_{load}$  value.

To find C1 and C2, use the following formula:

$$C = 2(C_{load} - C_{stray}) - C_{pg}$$

where  $C_{stray}$  is usually 2 pF to 3 pF, depending on board traces, and  $C_{pg}$  (pin-to-ground capacitance) is 4 pF for the ADV7184.

### Example:

$C_{load} = 30$  pF. C1 = 50 pF, C2 = 50 pF (in this case 47 pF is the nearest real-life cap value to 50 pF)

# TYPICAL CIRCUIT CONNECTION

An example of how to connect the ADV7184 video decoder is shown in Figure 50. For a detailed schematic diagram for the ADV7184, refer to the ADV7184 evaluation note, which can be obtained from a local ADI representative.

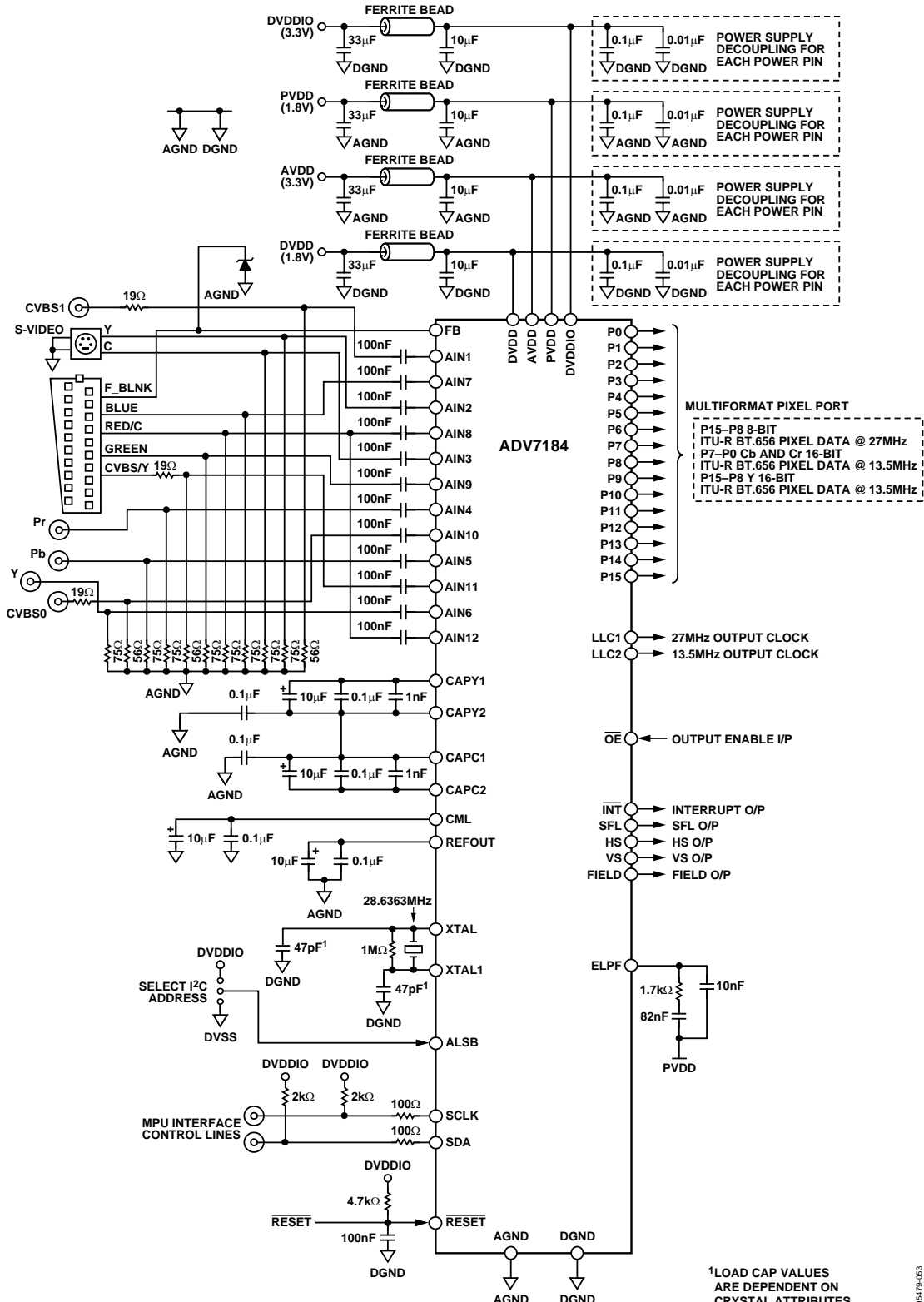

<sup>1</sup>LOAD CAP VALUES ARE DEPENDENT ON CRYSTAL ATTRIBUTES.

Figure 50. Typical Connection Diagram

# ADV7184

## OUTLINE DIMENSIONS

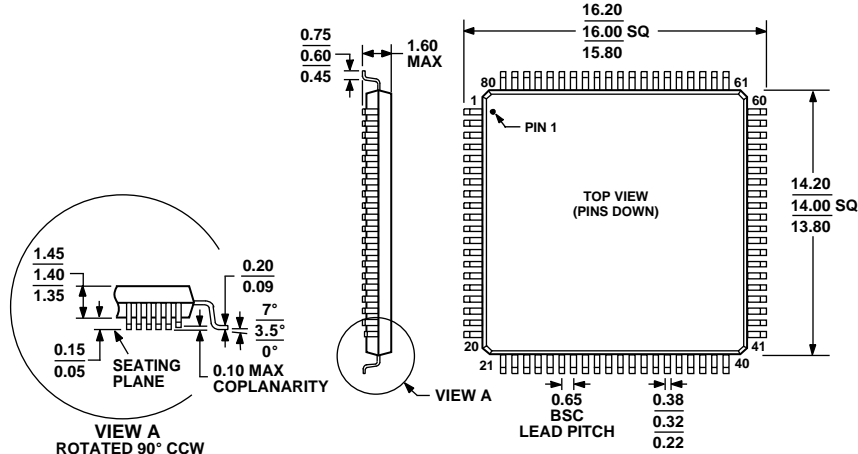

COMPLIANT TO JEDEC STANDARDS MS-026-BEC

Figure 51. 80-Lead Low Profile Quad Flat Package [LQFP] (ST-80-2)

Dimensions shown in millimeters

## ORDERING GUIDE

Model <sup>1</sup>	Temperature Range	Package Description	Package Option
ADV7184BSTZ <sup>2</sup>	-40°C to +85°C	Low Profile Quad Flat Package (LQFP)	ST-80-2
EVAL-ADV7184EB		Evaluation Board	

<sup>1</sup> The ADV7184 is a Pb-free, environmentally friendly product. It is manufactured using the most up-to-date materials and processes. The coating on the leads of each device is 100% pure Sn electroplate. The device is suitable for Pb-free applications, and is able to withstand surface-mount soldering at up to 255°C (±5°C). In addition, it is backward-compatible with conventional SnPb soldering processes. This means that the electroplated Sn coating can be soldered with SnPb solder pastes at conventional reflow temperatures of 220°C to 235°C.

<sup>2</sup> Z = Pb-free part.

Purchase of licensed I<sup>2</sup>C components of Analog Devices or one of its sublicensed Associated Companies conveys a license for the purchaser under the Philips I<sup>2</sup>C Patent Rights to use these components in an I<sup>2</sup>C system, provided that the system conforms to the I<sup>2</sup>C Standard Specification as defined by Philips.