

DLP Design

DLP-USB1

USB to FIFO Parallel Interface Module

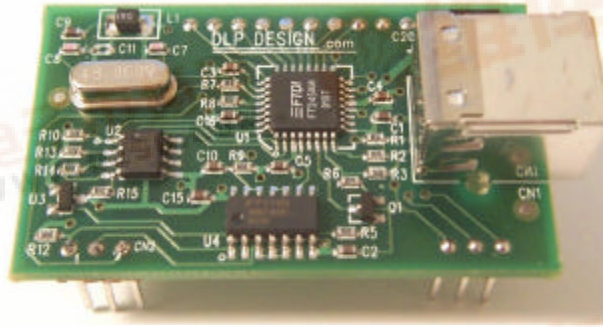

DLP-USB1 FEATURES

Send / Receive Data over USB at up to 1 M Bytes / sec
384 byte FIFO Transmit buffer / 128 byte FIFO receive buffer for high data throughput
Simple interface to CPU or MCU bus
No in-depth knowledge of USB required as all USB Protocol is handled automatically within the module
FTDI's Virtual COM port drivers eliminate the need for USB driver development in most cases.
Integrated 3.3v Regulator – No External Regulator Required
4.4v - 5.25v Single Supply taken directly from the USB port
UHCI / OHCI Compliant
USB 1.1 Specification Compliant
USB VID, PID, Serial Number and Product Description Strings stored in on-board EEPROM.
Virtual COM Port Drivers for Windows 98, Windows 98 SE, Windows 2000, Windows Millennium, Apple iMAC and Linux

Application Areas

Prototype Development
USB ISDN and ADSL Modems
High Speed USB PDA Interface
USB Interface for Digital Cameras
USB Interface for MP3 players
High Speed USB Instrumentation

GENERAL DESCRIPTION

The DLP-USB1 provides an easy cost-effective method of transferring data to / from a peripheral and a host at up to 8 Million bits (1 Megabyte) per second. It's simple FIFO-like design makes it easy to interface to any microcontroller or microprocessor via IO ports.

To send data from the peripheral to the host computer simply write the byte wide data into the module when TXE# is low. If the (384 byte) transmit buffer fills up or is busy storing the previously written byte, the device takes TXE# high in order to stop further data from being written until some of the FIFO data has been transferred over USB to the host.

When the host sends data to the peripheral over USB, the device will take RXF# low to let the peripheral know that data is available. The peripheral then reads the data until RXF# goes high indicating no more data is available to read.

By using FTDI's virtual COM Port drivers, the peripheral looks like a standard COM Port to the application software. Commands to set the baud rate are ignored – the device always transfers data at it's fastest rate regardless of the application's baud rate setting.

Application Notes

USB devices transfer data in packets. If data is to be sent from the PC, a packet is built up by the application program and is sent via the device driver to the USB scheduler. This scheduler puts a request onto the list of tasks for the USB host controller to perform. This will typically take at least 1 millisecond to execute because it will not pick up the new request until the next 'USB Frame' (the frame period is 1 millisecond).

There is therefore a sizeable overhead (depending on your required throughput) associated with moving the data from the application to the USB device. If data is sent 'byte at a time' by an application, this will severely limit the overall throughput of the system as a whole.

It must be stressed that in order to achieve maximum throughput, application programs should send or receive data using buffers and not individual characters.

Table 1 - DLP-USB1 PINOUT DESCRIPTION

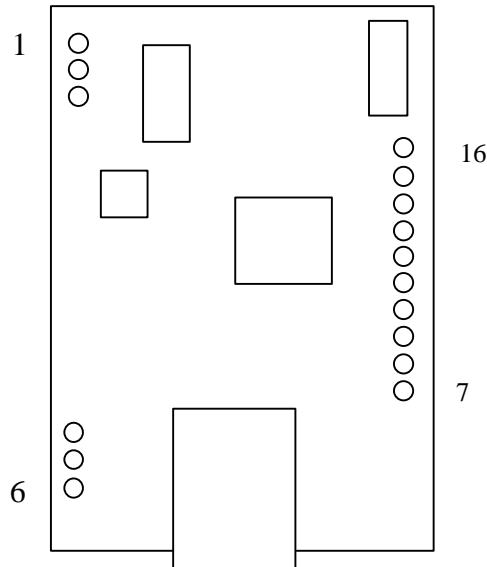

Pin#	Description
1	EXTRST# (IN) Take low to reset the entire device
2	SLEEP# (Out) Goes low when module enters the suspend mode
3	TXE# (Out) When high, the FIFO's 384-byte transmit buffer is full or busy storing the last byte written. Do not attempt to write data to the transmit buffer when TXE# is high.
4	RXF# (Out) When low, at least 1 byte is present in the FIFO's 128-byte receive buffer and is ready to be read with RD#. RXF# goes high when the receive buffer is empty.
5	WR (In) When taken from a high to a low state, WR reads the 8 data lines and writes the byte into the FIFO's transmit buffer. Data written to the transmit buffer is immediately sent to the host PC and placed in the RS-232 buffer opened by the application program.
6	RD# (In) When pulled low, RD# takes the 8 data lines from a high impedance state to the current byte in the FIFO's receive buffer. Taking RD# high returns the data pins to a high impedance state and prepares the next byte (if available) in the FIFO to be read.
7	VCC Provides power for target electronics. Up to 500mA available when USB is active.
8	GND Ground Supply Pin for target electronics.
16	D0 I/O Bi-directional Data Bus Bit # 0
15	D1 I/O Bi-directional Data Bus Bit # 1
14	D2 I/O Bi-directional Data Bus Bit # 2
13	D3 I/O Bi-directional Data Bus Bit # 3
12	D4 I/O Bi-directional Data Bus Bit # 4
11	D5 I/O Bi-directional Data Bus Bit # 5
10	D6 I/O Bi-directional Data Bus Bit # 6
9	D7 I/O Bi-directional Data Bus Bit # 7

DLP-USB1 TIMING DIAGRAM – FIFO READ CYCLE

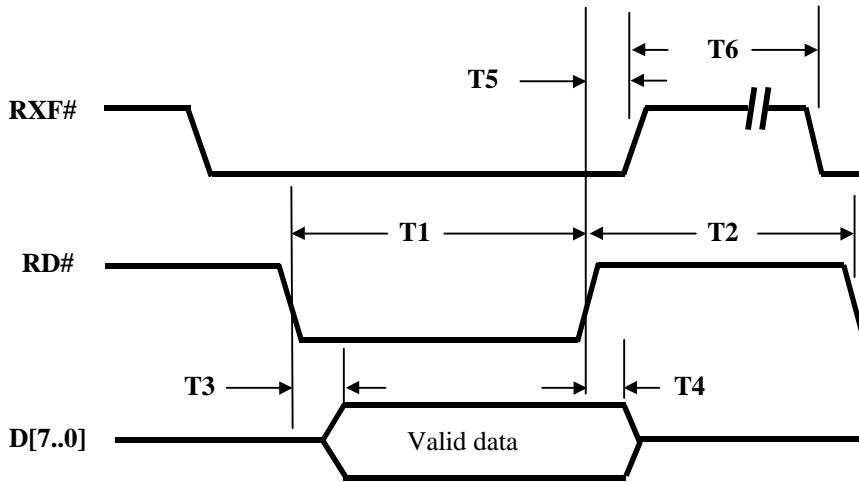

Time	Description	Min	Max	Unit
T1	RD Active Pulse Width	50		ns
T2	RD to RD Pre-Charge Time	50		ns
T3	RD Active to Valid Data		30	ns
T4	Valid Data Hold Time from RD Inactive	10		ns
T5	RD Inactive to RXF#	5	25	ns
T6	RXF# inactive after RD cycle	80		ns

DLP-USB1 TIMING DIAGRAM – FIFO WRITE CYCLE

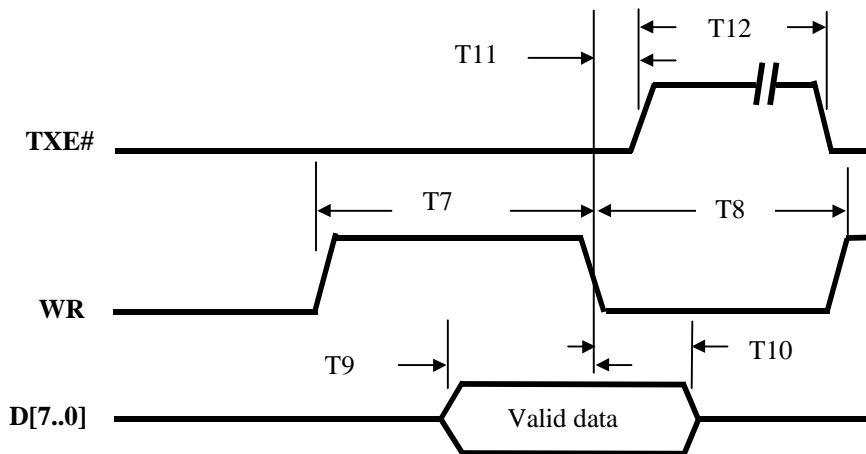

Time	Description	Min	Max	Unit
T7	WR Active Pulse Width	50		ns
T8	WR to WR Pre-Charge Time	50		ns
T9	Data Setup Time before WR inactive		20	ns
T10	Data Hold Time from WR inactive	10		ns
T11	WR Inactive to TXE#	5	25	ns
T12	TXE# inactive after RD cycle	80		Ns

Mechanical Drawings (PRELIMINARY)

Inches(millimeters) unless otherwise noted

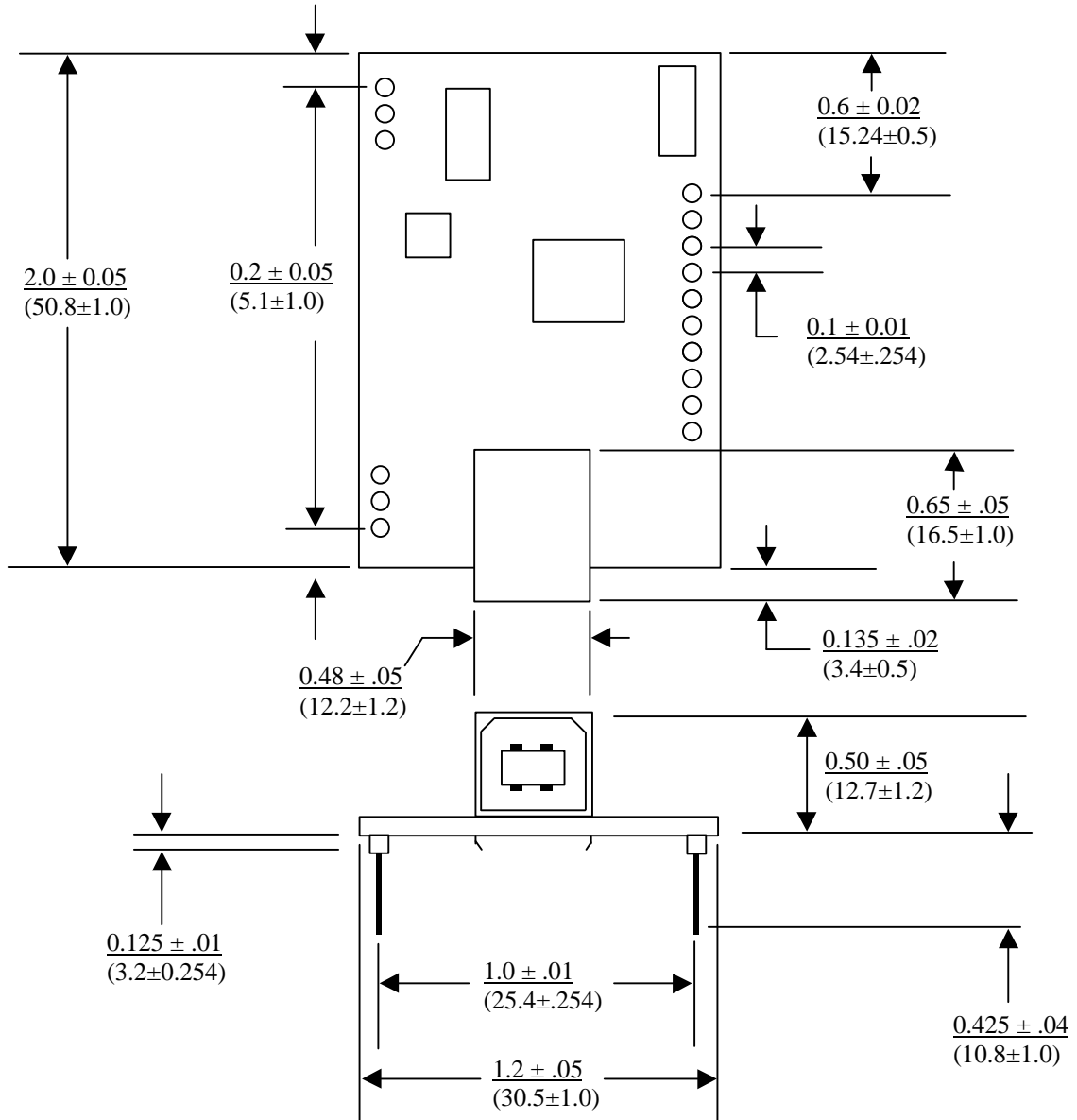

Absolute Maximum Ratings

Storage Temperature	-65°C to + 150°C
Ambient Temperature (Power Applied)	0°C to + 70°C
VCC Supply Voltage	-0.5v to +6.00v
DC Input Voltage - Inputs	-0.5v to VCC + 0.5v
DC Input Voltage - High Impedance Bidirectionals	-0.5v to VCC + 0.5v
DC Output Current – Outputs	24mA
DC Output Current – Low Impedance Bidirectionals	24mA

DC Characteristics (Ambient Temperature = 0 - 70 Degrees C)

	Description	Min	Max	Units	Condition
VCC	Operating Supply Voltage	4.5	5.25	V	
Icc1	Operating Supply Current		50	mA	Normal Operation
Icc2	Operating Supply Current		250 **	uA	USB Suspend
Ioh1	Digital IO Pins Source Current	4		mA	Voh = VCC – 0.5V
Iol1	Digital IO Pins Sink Current	4		mA	Vol = + 0.5v
Voh1	Input Voltage Threshold (Low)		0.6	V	
Vol1	Input Voltage Threshold (High)	2.7		V	
VDif	USB Differential Input Sensitivity	0.2		V	
VCom	USB Differential Common Mode	0.8	2.5	V	
URxt	USB Single Ended Rx Threshold	0.8	2.0	V	
UVh	USB IO Pins Static Output (Low)		0.3	V	RI = 1.5k to 3.6v
UVI	USB IO Pins Static Output (High)	2.8			RI = 15k to GND

** Some early samples may exhibit a slightly higher current.

Disclaimer

Neither the whole nor any part of the information contained in, or the product described in this datasheet, may be adapted or reproduced in any material or electronic form without the prior written consent of the copyright holder.

This product and its documentation are supplied on an as is basis and no warranty as to their suitability for any particular purpose is either made or implied. DLP Design will not accept any claim for damages howsoever arising as a result of use or failure of this product. Your statutory rights are not affected.

This product or any variant of it is not intended for use in any medical appliance, device or system in which the failure of the product might reasonably be expected to result in personal injury.

This document provides preliminary information that may be subject to change without notice.

Contact Information

DLP Design
 PO Box 503762
 San Diego, CA 92150-3762
 Phone: 858-513-2777
 Fax: 858-513-2777
 Email: support@dlpdesign.com
 Internet: <http://www.dlpdesign.com>