

DM-3100N

Low Cost, 3½ Digit, LED Display in Low Profile Case

FEATURES

- **Balanced differential inputs, 5pA bias current, autozeroing with 80 db CMR noise rejection**
- **1000 M^Ω CMOS high impedance inputs, ±1.999 Vdc FS range**
- **3½ digits, .56" high LED displays, 5V-powered, ratiometric reference for drift correction**
- **Low Profile Case measures 2.53"W × 3.34"D × 0.94"H (64,3 × 84,8 × 23,8 mm)**
- **Accepts optional 4-20 mA inputs**
- **Accepts optional potentiometer for offsetting a zero input**



GENERAL DESCRIPTION

The DM-3100N is a 3½ digit Digital Panel Meter which uses solid-state self-illuminated, light-emitting diode (LED) displays. their large size (0.56" high) and brilliant red light make them easily readable from many feet away. This DPM is contained in a compact low profile case which makes for higher packing density on test panel faces. Besides measuring DC voltages, components can be internally installed by the user to make resistance and current readings. The decimal point can also be externally selected by jumpering appropriate pins.

The versatility of this meter is further enhanced by its auto-zeroing capabilities, or if the customer desires, a pot can be internally installed by the user so that an offset can be obtained with a zero input to the meter, or a zero reading with an offset input.

This DPM accepts a DC or slowly-varying input voltage between ±1.999V and displays that input on front panel numerical indicators. It employs a conventional dual-slope A/D converter plus 7 segment display decoder-drivers all in one LSI microcircuit. Since this microcircuit requires approximately 10V to power the A/D section, an internal DC/DC converter generates -5V from +5V power input to form a bipolar supply.

The DM-3100N is identical to the DM-3100L, except that a low-

profile case style is used and there is PC board room to accept the optional offset pot.

Open PC board pads are provided on the DM-3100N to accept user-supplied input voltage attenuators, current shunts, digital ohmmeter components or an offset pot for applications such as 4-20 mA process control measurement.

Another feature of the DM-3100N is that a balanced differential input is used. When used with bridge or transducer inputs, it offers high noise immunity and can accurately measure very small signals in the presence of much larger common mode signals. Another characteristic of this balanced differential input is that it will not load down sensitive input circuits, due to its high input impedance, 100 megohms, and low 5 pA bias current.

A very noteworthy feature of this meter is that it can be operated ratiometrically. This means that it has internal circuits that can automatically compensate for reference drifts in the supplies of balanced bridge or transducer sensors.

The DM-3100N finds use in analytical instruments, industrial process controllers, portable diagnostic instruments, automatic test equipment, medical and patient monitoring instruments, airborne, marine and ground vehicles and data acquisition/data logging systems.

DM-3100N SIMPLIFIED BLOCK DIAGRAM

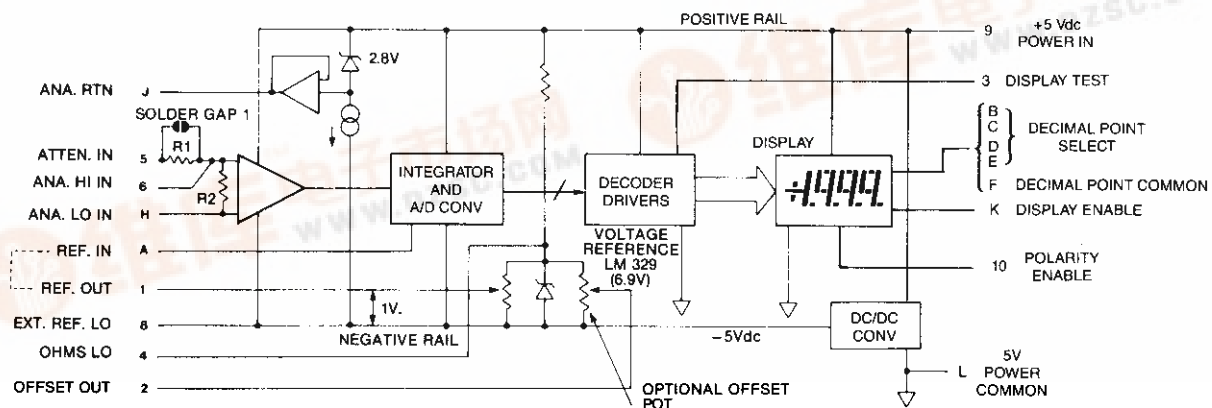

SPECIFICATIONS (Typical @ +25°C unless noted)**ANALOG INPUT**

Configuration	True, balanced differential bipolar
Full Scale Input Range	–1.999 Vdc to +1.999Vdc Input pad area will accept user-installed range change
Input Bias Current	5 pA typical, 50 pA maximum
Displayed Accuracy @ +25°C	Adjustable to ±0.1% of reading, ±1 count
Resolution	1 mV
Temperature Drift of Zero	Autozeroed ±1 count over 0 to +50°C
Temperature Drift of Gain	±50 ppm of Reading/°C typ. ±100 ppm of Reading/°C max.
Input Impedance	100 Megohms, minimum
Input Overvoltage	±250 Volts dc 175 VRMS continuous max. ±300 Volts intermittent max.
Common Mode Rejection	80 dB, DC to 60 Hz, 1 Kiloohm unbalance
Common Mode Voltage Range	Within +Vs, –.5V and –Vs +1V where +Vs is the positive rail (Pin 9) and –Vs is the negative rail (Pin 8) –Vs is approximately equal to –5V below PWR. COM.
Warm-up Time	Within 10 minutes
External Ref. Range	+100mV to +2V, referred to –Vs
Ramp-up Time (Integration Period)	83.3 mS.
Reference	Internal, referred to the negative rail (– Vs). External, user-supplied reference optional for ratiometric operation.

DISPLAY

Number of Digits	3 decimal digits and most significant "1" digit (3½ digits)
Decimal Points	Selectable decimal points are included for scale multipliers.
Display Type	Red, light-emitting diode (LED) self illuminated.
Display Height	0.56 inches (14.2 mm)
Overscale	Inputs exceeding the full scale range blank the display, leaving a "1" MSD and sign
Autopolarity	A minus sign is automatically displayed for negative inputs, and may also be blanked
Sampling Rate	Factory set at 3 conversions per second. May be rewired up to 20 conversions/second.

I/O CONNECTIONS

Analog Hi Input (Pin 6)	Differential input voltages are connected between these inputs. A bias current path to POWER COMMON (if 5V-powered) or ANALOG RETURN from both these inputs must be externally provided. External circuits must constrain these inputs to be within the common mode voltage range.
Analog L.O. Input (Pin H)	This pin may be used as a low-noise bias current for some floating inputs. If not possible, inputs may be referenced to POWER COMMON (if 5V-powered). Analog Return is approximately –2.8V below +Vs and can sink 30 mA to –Vs.
Analog Return (Pin J)	Normally, REF. IN and REF. OUT (Pins A/1) should be jumpered together. An external floating source referred to EXT. REF. LO (Pin 8) may be substituted for ratiometric operation.
Reference In/Out (Pins A/1)	Connect selected pin to DECIMAL POINT COMMON (Pin F)
Decimal Points (Pins B-E)	0 to +6.9V referred to –Vs (Pin 8) requires installation of optional offset pot supplied by user.
Offset Out (Pin 2)	

Display Enable (Pin K)	Connect to +5 Vdc power to illuminate display. Disconnect to blank display but keep A/D converter cycling.
Display Test (Pin 3)	Connect this input to +5 Vdc to light all display segments.
Polarity Enable (Pin 10)	Ground this input to automatically display a minus sign for negative inputs.
Ohms Lo (Pin 4)	This connection is used in the ohmmeter configuration, otherwise do not use.

POWER CONNECTIONS

+5 VDC Power IN (Pin 9)	Connect this pin to +5 Vdc regulated to power the A/D converter and displays.
5V Power Common (Pin L)	This pin may be used as a bias current return path for some inputs. Connect to Power Ground.
POWER REQUIREMENTS	External +5, ±0.25 Vdc regulated required at 280 mA typical, 450 mA max. Logic spikes must not exceed 50 mV. Power current varies rapidly so that unregulated supplies cannot be used.
Calibration	A multiturn screwdriver pot adjusts the full scale reading (gain). Zero is automatic (autozeroing). Suggested recalibration in stable conditions is 90 days.

PHYSICAL-ENVIRONMENTAL

Low Profile Case	Interchangeable with other Datel-Intersil cases.
Outline Dimensions	2.53"Wx3.34"Dx0.94"H (64,3x84,8x23,8 mm)
Cutout Dimensions	2.56"Wx0.97"H (65,1x24,6 mm)
Mounting Method	Through a front panel cutout secured by 2 side case "L" brackets and screws (supplied). Panel thickness up to 0.62" (15,9 mm)
Weight	Approximately 5 ounces (142g)
Connector	Double-sided edgeboard PC type, solder tab, gold-plated fingers. Dual 10-pin, 0.156" centers.
Mounting Position	Any
Operating Temperature Range	0 to +50°C
Storage Temperature Range	–25 to +85°C
Altitude	0 to 15,000 feet (4900m)
Relative Humidity	20% to 80% non-condensing

Ordering Information

DM-3100N-1: ±2Vdc Input Range
(Supplied With Free Connector)

RN-3100/4100: Range-Change
Accessory Kit for DM-Series Meters

DM-3100N COMPONENT LOCATIONS *

NOTES:

(1) R1, R2 ARE USER-INSTALLED ATTENUATION OR (R2) SHUNT RESISTORS. BEFORE INSTALLING RESISTORS AT R1, OPEN SOLDER GAP (SG1) ON COMP. SIDE OF BOARD WITH A SOLDERING IRON. NOTE THAT, IF R1 IS LATER REMOVED, THE USER MUST CLOSE THE SOLDER GAP.

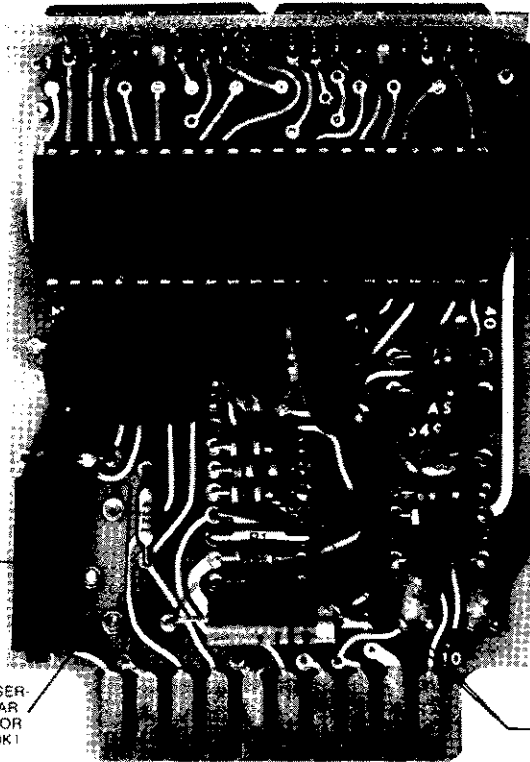

* Refer to DATEL RN-3100/4100 Range-Change Accessory Kit data sheet for detailed modification instructions and R1 & R2 locations.

INPUT/OUTPUT CONNECTIONS WITH SINGLE-ENDED INPUT DM-3100N

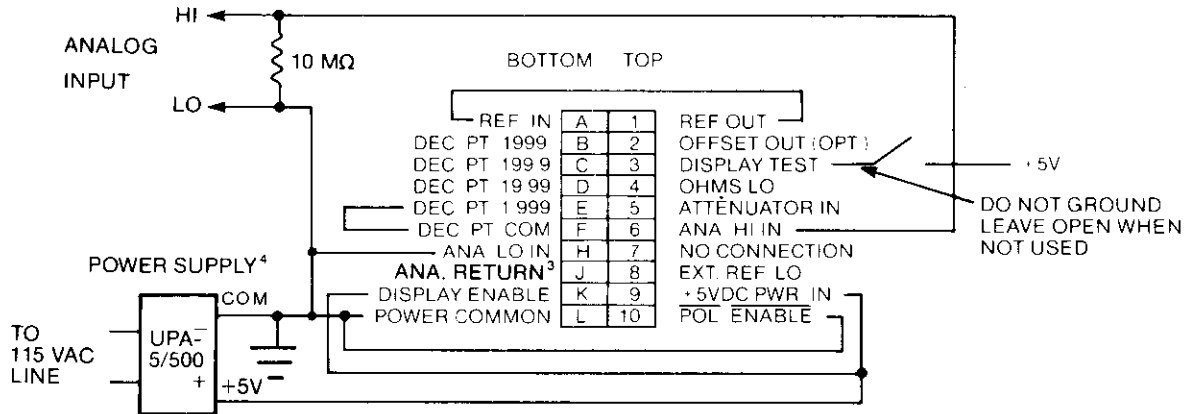

NOTES:

1. This shows the connector rear view with the DPM tilted on its side.
2. CAUTION: This DPM employs high impedance CMOS inputs. Although internal protection is provided for several hundred volt overloads, this DPM will be destroyed by kilovolts of static discharge which is especially prevalent in low humidity environments. Always handle the DPM with ground protection.
3. ANALOG RETURN = +Vs - 2.8 Vdc. DO NOT CONNECT TO POWER COMMON.
4. UPA-5/500 is a user-supplied and user-installed DATEL-INTERSIL accessory.

MECHANICAL DIMENSIONS INCHES (MM)

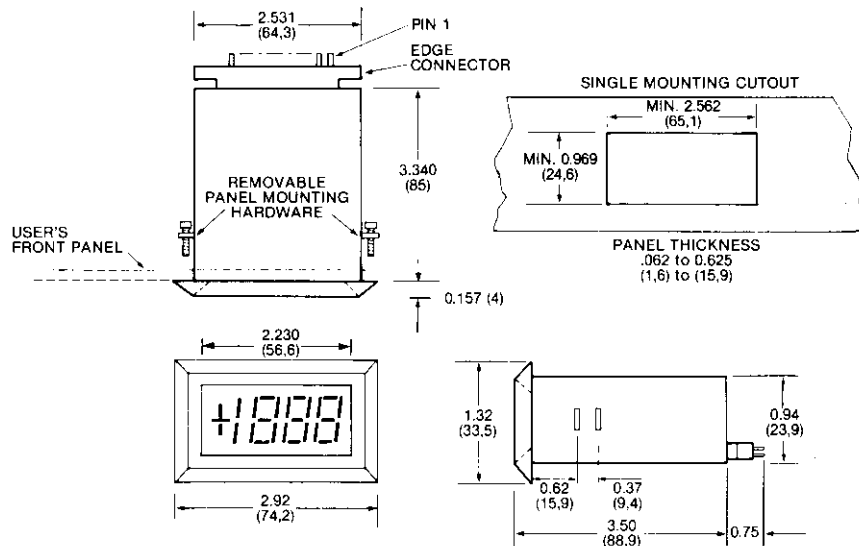

PANEL MOUNTING

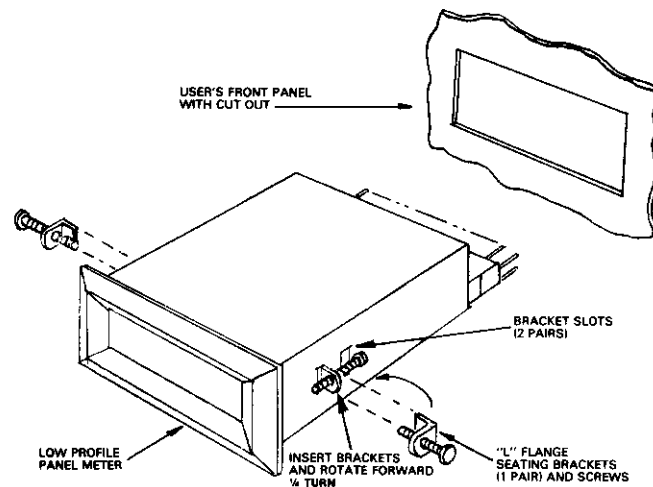

PANEL INSTALLATION INSTRUCTIONS

The low profile case is retained in a front panel cutout by sliding the DPM housing in through the cutout opening and securing the housing from the rear using 2 "L" brackets and screws. Proceed as follows:

1. After determining the correct position, form a cutout in the mounting panel. Refer to the cutout drawing for proper dimensions.
2. Install the panel meter from the front (display) side of the mounting panel as shown.
3. There are two pairs of slots in the side of the case to receive the L-brackets and retaining screws. Most applications will use the front pair of slots. For panels thicker than about 0.25 inches (6 mm), use the rear slot pair.
4. A thin plastic molding may cover the selected slots. This can be broken through with the L brackets in the next step or can be removed using a screwdriver or knife before panel mounting.
5. Assemble the supplied 4-40 screws into the L brackets as shown, turning the screw until several threads are engaged.
6. **Using the screw as a lever**, push the short side of the bracket into the slot as shown and **rotate the**

screw backwards ¼ turn until the screw is parallel to the case side and the L bracket is fully captured in the case.

7. Lightly tighten the screws against the front panel.

CIRCUIT BOARD ACCESS

If access to the internal circuit board is required, bow the rear cover plate backward by prying up in the center with a small screwdriver or knife blade, to release the two catches in the side of the case. When reinstalling the circuit board, first be sure the front filter is flush against the inside of the housing. The circuit board engages a pair of guide tracks which are molded inside the case. When reinstalling the rear cover plate, be sure the trim pot access hole is to the lower left when facing the rear. Compress the cover plate slightly so that it snaps into the two retaining slot catches at the rear sides.

If a second user-fabricated circuit board is installed in the upper pair of board guide tracks, the upper connector slot (if used) in the rear cover plate may be opened by using a knife from inside the cover.

APPLICATION**Measuring a 4-to-20 mA Process Control Signal**

The DM-3100N may be used with ISA type L, H, and U 4-to-20mA transmitters. The current loop is connected to the DPM's ANALOG HI IN and POWER COMMON through a shunt resistor, R. The value of R depends on the user's scaling requirements. A typical configuration uses a 50K ohm potentiometer for offset adjustment. Adjust this pot for the desired low limit reading (or zero) in volts to be displayed by the DPM. Figure 2 shows a DPM driven by a 4-20mA current loop.

To determine the value of R, the user should determine the maximum value in volts the DPM will display. For example, if the maximum value the DPM will display is 1500, it corresponds to an input voltage to the DPM of 1.5 volts. Use the following equation to calculate the value of R.

Finding R

Maximum value (1500 counts) to be displayed in volts = 1.5v

$$R = \frac{1.5}{(20-4)\text{mA}} = 9.375 \text{ ohms}$$

CALIBRATION PROCEDURE

1. Apply 4 mA from a calibrated external current source.
2. Adjust the offset pot for the desired low reading (or zero).
3. Apply 20 mA from the current source.
4. Adjust the DPM's full scale gain pot for the desired high value.
5. Both adjustments interact slightly, therefore, repeat steps 1-4 until no further improvement can be obtained.

It is common for industrial 4-20 mA sources to represent 0 to 150 P.S.I. for example, as 4 to 20 mA. Therefore, the DPM can be adjusted to directly display engineering units.

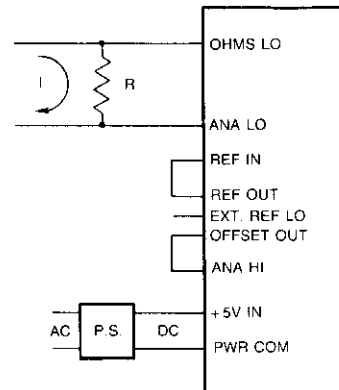

Figure 2. DM-3100N Application

A1000

- NOTES:
1. A 50KΩ potentiometer must be installed on the DPM Board between EXT REF LO/OFFSET OUT (R16).
 2. This circuit configuration is applicable for Models DM-3100N, DM-3100UL, DM-3100U2 and DM-3100U3.
 3. The current source must be isolated (floating) for this circuit to work. There must not be any ohmic path to ground, from the 4-20 mA current source. If this cannot be done, float the whole DPM by using a transformer-isolated + 5 Vdc power supply such as DATEL's UPA-5/500. Note the correct polarity for the current source.