



PRELIMINARY
March 2006

DS25MB200

Dual 2.5 Gb/s 1:2 Mux/Buffer with Input Equalization and Output Pre-Emphasis

General Description

The DS25MB200 is a dual signal conditioning 2:1 multiplexer and 1:2 fan-out buffer designed for use in backplane redundancy applications. Signal conditioning features include input equalization and programmable output pre-emphasis that enable data communication in FR4 backplanes up to 2.5 Gb/s. Each input stage has a fixed equalizer to reduce ISI distortion from board traces. All output drivers have 4 selectable steps of pre-emphasis to compensate for transmission losses from long FR4 backplanes and reduce deterministic jitter. The pre-emphasis levels can be independently controlled for the line-side and switch-side drivers. The internal loopback paths from switch-side input to switch-side output enable at-speed system testing. All receiver inputs and driver outputs are internally terminated with 100Ω differential terminating resistors.

Features

- Dual 2:1 multiplexer and 1:2 buffer
- 0.8–2.5 Gbps fully differential data paths
- Fixed input equalization
- Programmable output pre-emphasis
- Independent switch and line side pre-emphasis controls
- Programmable switch-side loopback modes
- On-chip terminations
- HBM ESD rating 6 kV on all pins
- +3.3V supply
- Low power, 1W max
- Lead-less LLP-48 package (7mm x 7mm x 0.8mm, 0.5mm pitch)
- -40°C to +85°C operating temperature range

Functional Block Diagram

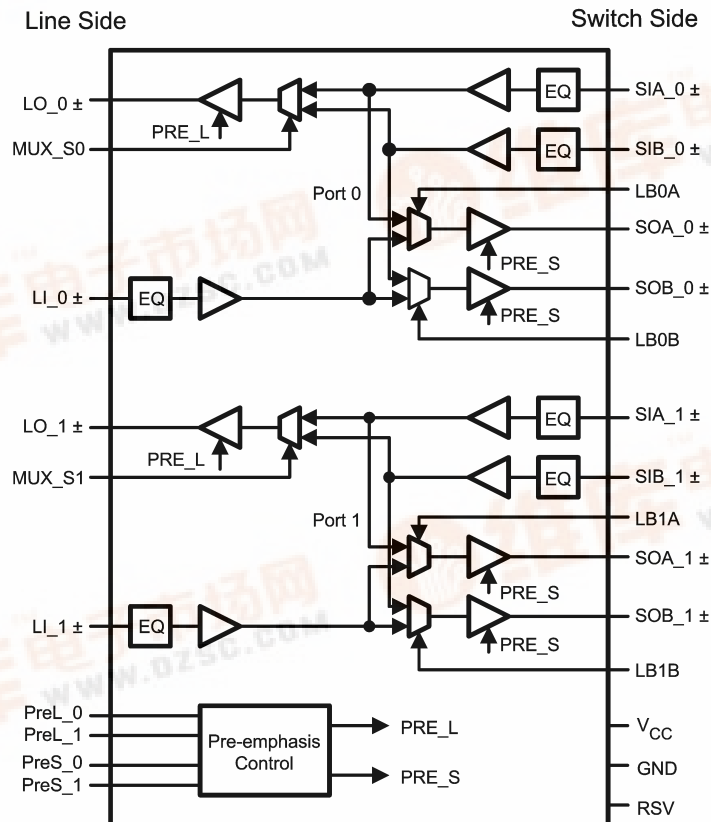

20182333

DS25MB200 Dual 2.5 Gb/s 1:2 Mux/Buffer with Input Equalization and Output Pre-Emphasis



Simplified Block Diagram

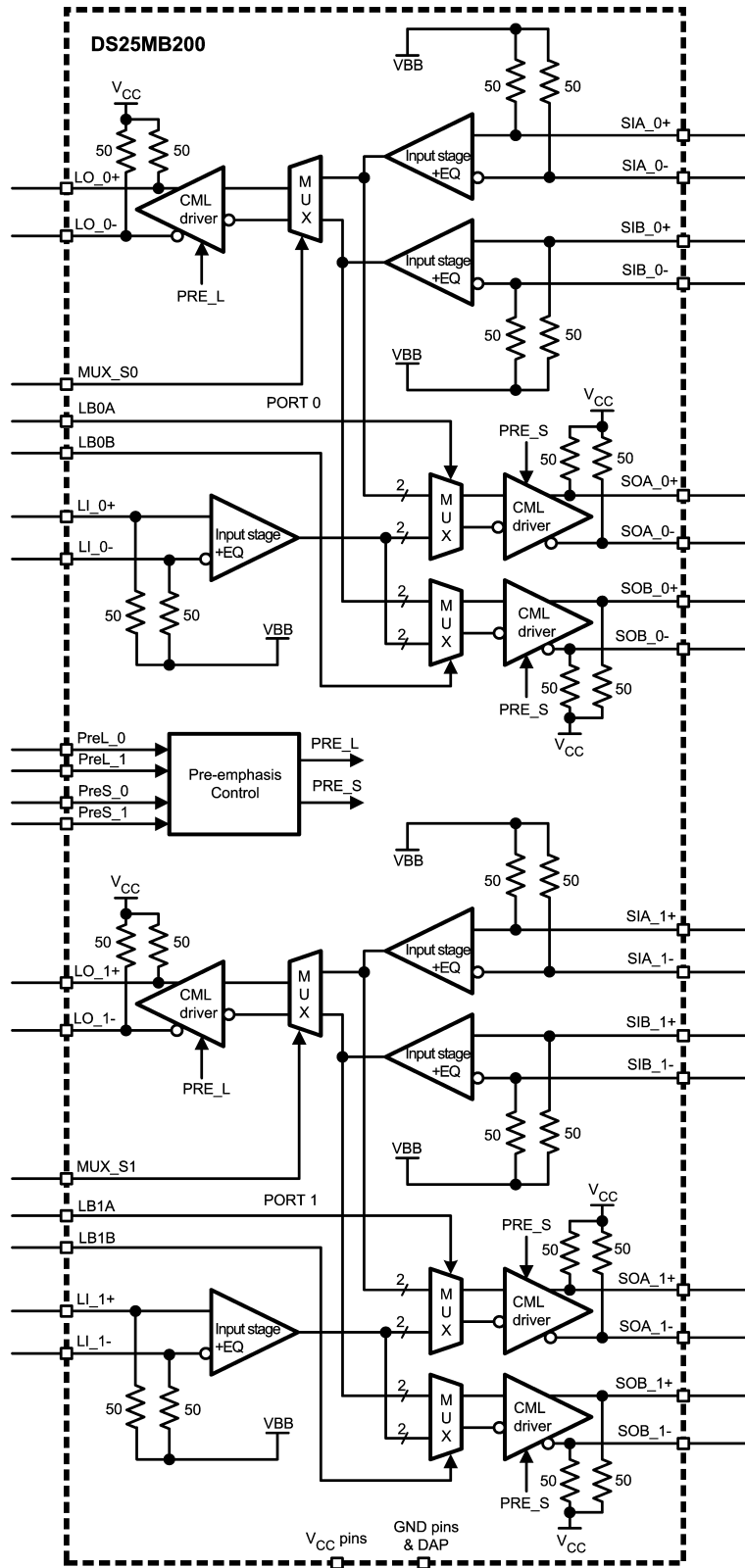

20182331

Connection Diagram

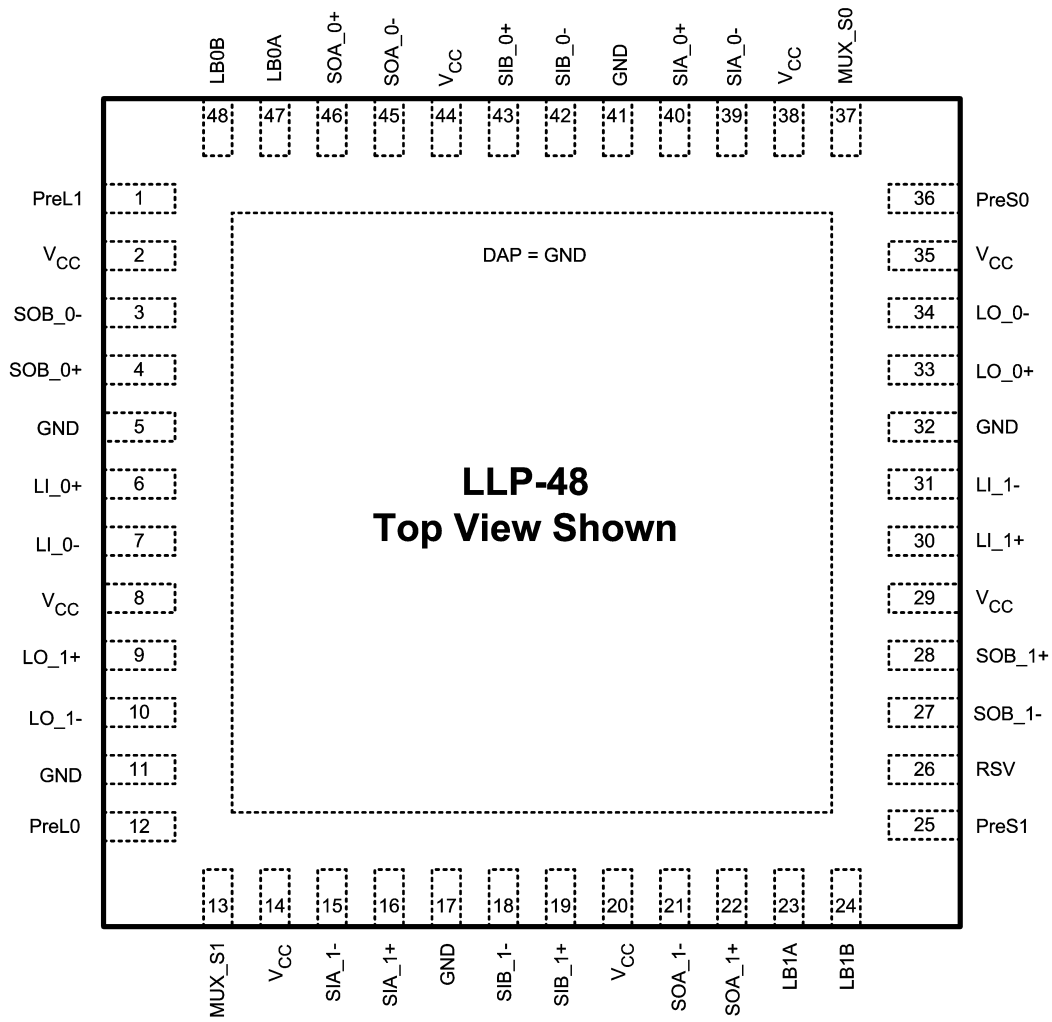

Order Number DS25MB200TSQ
See NS Package Number NSQAV48

20182332

Pin Descriptions

Pin Name	Pin Number	I/O	Description
LINE SIDE HIGH SPEED DIFFERENTIAL IO's			
LI_0+	6	I	Inverting and non-inverting differential inputs of port_0 at the line side. LI_0+ and LI_0- have an internal 50Ω connected to an internal reference voltage.
LI_0-	7		
LO_0+	33	O	Inverting and non-inverting differential outputs of port_0 at the line side. LO_0+ and LO_0- have an internal 50Ω connected to V _{CC} .
LO_0-	34		
LI_1+	30	I	Inverting and non-inverting differential inputs of port_1 at the line side. LI_1+ and LI_1- have an internal 50Ω connected to an internal reference voltage.
LI_1-	31		
LO_1+	9	O	Inverting and non-inverting differential outputs of port_1 at the line side. LO_1+ and LO_1- have an internal 50Ω connected to V _{CC} .
LO_1-	10		
SWITCH SIDE HIGH SPEED DIFFERENTIAL IO's			
SOA_0+	46	O	Inverting and non-inverting differential outputs of mux_0 at the switch_A side. SOA_0+ and SOA_0- have an internal 50Ω connected to V _{CC} .
SOA_0-	45		
SOB_0+	4	O	Inverting and non-inverting differential outputs of mux_0 at the switch_B side. SOB_0+ and SOB_0- have an internal 50Ω connected to V _{CC} .
SOB_0-	3		
SIA_0+	40	I	Inverting and non-inverting differential inputs to the mux_0 at the switch_A side. SIA_0+ and SIA_0- have an internal 50Ω connected to an internal reference voltage.
SIA_0-	39		
SIB_0+	43	I	Inverting and non-inverting differential inputs to the mux_0 at the switch_B side. SIB_0+ and SIB_0- have an internal 50Ω connected to an internal reference voltage.
SIB_0-	42		
SOA_1+	22	O	Inverting and non-inverting differential outputs of mux_1 at the switch_A side. SOA_1+ and SOA_1- have an internal 50Ω connected to V _{CC} .
SOA_1-	21		
SOB_1+	28	O	Inverting and non-inverting differential outputs of mux_1 at the switch_B side. SOB_1+ and SOB_1- have an internal 50Ω connected to V _{CC} .
SOB_1-	27		
SIA_1+	16	I	Inverting and non-inverting differential inputs to the mux_1 at the switch_A side. SIA_1+ and SIA_1- have an internal 50Ω connected to an internal reference voltage.
SIA_1-	15		
SIB_1+	19	I	Inverting and non-inverting differential inputs to the mux_1 at the switch_B side. SIB_1+ and SIB_1- have an internal 50Ω connected to an internal reference voltage.
SIB_1-	18		
CONTROL (3.3V LVCMOS)			
MUX_S0	37	I	A logic low at MUX_S0 selects mux_0 to switch B. MUX_S0 is internally pulled high. Default state for mux_0 is switch A.
MUX_S1	13		A logic low at MUX_S1 selects mux_1 to switch B. MUX_S0 is internally pulled high. Default state for mux_1 is switch A.
PREL_0	12	I	PREL_0 and PREL_1 select the output pre-emphasis of the line side drivers (LO_0± and LO_1±). PREL_0 and PREL_1 are internally pulled high. See <i>Table 3</i> for line side pre-emphasis levels.
PREL_1	1		
PRES_0	36	I	PRES_0 and PRES_1 select the output pre-emphasis of the switch side drivers (SOA_0±, SOB_0±, SOA_1± and SOB_1±). PRES_0 and PRES_1 are internally pulled high. See <i>Table 4</i> for switch side pre-emphasis levels.
PRES_1	25		
LB0A	47	I	A logic low at LB0A enables the internal loopback path from SIA_0± to SOA_0±. LB0A is internally pulled high.
LB0B	48	I	A logic low at LB0B enables the internal loopback path from SIB_0± to SOB_0±. LB0B is internally pulled high.
LB1A	23	I	A logic low at LB1A enables the internal loopback path from SIA_1± to SOA_1±. LB1A is internally pulled high.
LB1B	24	I	A logic low at LB1B enables the internal loopback path from SIB_1± to SOB_1±. LB1B is internally pulled high.
RSV	26	I	Reserve pin to support factory testing. This pin can be left open, or tied to GND, or tied to GND through an external pull-down resistor.

Pin Descriptions (Continued)

Pin Name	Pin Number	I/O	Description
POWER			
V _{CC}	2, 8, 14, 20, 29, 35, 38, 44	P	V _{CC} = 3.3V ± 5%. Each V _{CC} pin should be connected to the V _{CC} plane through a low inductance path, typically with a via located as close as possible to the landing pad of the V _{CC} pin. It is recommended to have a 0.01 μF or 0.1 μF, X7R, size-0402 bypass capacitor from each V _{CC} pin to ground plane.
GND	5, 11, 17, 32, 41	P	Ground reference. Each ground pin should be connected to the ground plane through a low inductance path, typically with a via located as close as possible to the landing pad of the GND pin.
GND	DAP	P	Die Attach Pad (DAP) is the metal contact at the bottom side, located at the center of the LLP-48 package. It should be connected to the GND plane with at least 4 via to lower the ground impedance and improve the thermal performance of the package.

Functional Description

The DS25MB200 is a signal conditioning 2:1 multiplexer and a 1:2 buffer designed to support port redundancy up to 2.5 Gb/s. Each input stage has a fixed equalizer that provides equalization to compensate about 5 dB of transmission loss from a short backplane trace (about 10 inches backplane). The output driver has pre-emphasis (driver-side equalization) to compensate the transmission loss of the backplane that it is driving. The driver conditions the output signal such that the lower frequency and higher frequency pulses reach approximately the same amplitude at the end of the backplane, and minimize the deterministic jitter caused by the

amplitude disparity. The DS25MB200 provides 4 steps of user-selectable pre-emphasis ranging from 0, -3, -6 and -9 dB to handle different lengths of backplane. *Figure 1* shows a driver pre-emphasis waveform. The pre-emphasis duration is 188 ps nominal, corresponds to 0.47 bit-width at 2.5 Gb/s. The pre-emphasis levels of switch-side and line-side can be individually programmed.

The high speed inputs are self-biased to about 1.5V and are designed for AC coupling. The inputs are compatible to most AC coupling differential signals such as LVDS, LVPECL and CML.

TABLE 1. LOGIC TABLE FOR MULTIPLEX CONTROLS

MUX_S0	Mux Function
0	MUX_0 select switch_B input, SIB_0±.
1 (default)	MUX_0 select switch_A input, SIA_0±.
MUX_S1	Mux Function
0	MUX_1 select switch_B input, SIB_1±.
1 (default)	MUX_1 select switch_A input, SIA_0±.

TABLE 2. LOGIC TABLE FOR LOOPBACK CONTROLS

LB0A	Loopback Function
0	Enable loopback from SIA_0± to SOA_0±.
1 (default)	Normal mode. Loopback disabled.
LB0B	Loopback Function
0	Enable loopback from SIB_0± to SOB_0±.
1 (default)	Normal mode. Loopback disabled.
LB1A	Loopback Function
0	Enable loopback from SIA_1± to SOA_1±.
1 (default)	Normal mode. Loopback disabled.
LB1B	Loopback Function
0	Enable loopback from SIB_1± to SOB_1±.
1 (default)	Normal mode. Loopback disabled.

Functional Description (Continued)

TABLE 3. LINE-SIDE PRE-EMPHASIS CONTROLS

PreL_[1:0]	Pre-Emphasis Level in mV_{PP} (VODB)	De-Emphasis Level in mV_{PP} (VODPE)	Pre-Emphasis in dB (VODPE/VODB)	Typical FR4 board trace
0 0	1200	1200	0	10 inches
0 1	1200	849.53	-3	20 inches
1 0	1200	600	-6	30 inches
1 1 (default)	1200	425.78	-9	40 inches

TABLE 4. SWITCH-SIDE PRE-EMPHASIS CONTROLS

PreS_[1:0]	Pre-Emphasis Level in mV_{PP} (VODB)	De-Emphasis Level in mV_{PP} (VODPE)	Pre-Emphasis in dB (VODPE/VODB)	Typical FR4 board trace
0 0	1200	1200	0	10 inches
0 1	1200	849.53	-3	20 inches
1 0	1200	600	-6	30 inches
1 1 (default)	1200	425.78	-9	40 inches

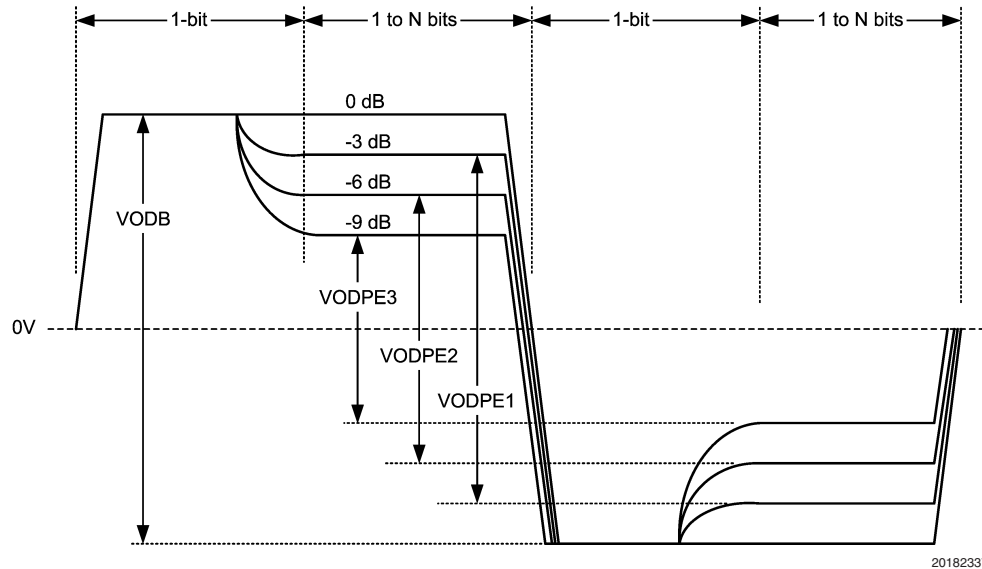

FIGURE 1. Driver Pre-Emphasis Differential Waveform (showing all 4 pre-emphasis steps)

Absolute Maximum Ratings (Note 1)

If Military/Aerospace specified devices are required, please contact the National Semiconductor Sales Office/Distributors for availability and specifications.

Supply Voltage (V_{CC})	-0.3V to 4V
CMOS/TTL Input Voltage	-0.3V to ($V_{CC} + 0.3V$)
CML Input/Output Voltage	-0.3V to ($V_{CC} + 0.3V$)
Junction Temperature	+150°C
Storage Temperature	-65°C to +150°C
Lead Temperature	
Soldering, 4 sec	+260°C
Thermal Resistance, θ_{JA}	33.7°C/W

Thermal Resistance, θ_{JC-top}	20.7°C/W
Thermal Resistance, $\theta_{JC-bottom}$	5.8°C/W
Thermal Resistance, Φ_{JB}	18.2°C/W
ESD Rating HBM, 1.5 k Ω , 100 pF	6 kV

Recommended Operating Ratings

	Min	Typ	Max	Units
Supply Voltage (V_{CC-GND})	3.135	3.3	3.465	V
Supply Noise Amplitude 10 Hz to 2 GHz			50	mV _{PP}
Ambient Temperature	-40		85	°C
Case Temperature			100	°C

Electrical Characteristics

Over recommended operating supply and temperature ranges unless otherwise specified.

Symbol	Parameter	Conditions	Min	Typ (Note 2)	Max	Units
LVC MOS DC SPECIFICATIONS						
V_{IH}	High Level Input Voltage		2.0		$V_{CC} + 0.3$	V
V_{IL}	Low Level Input Voltage		-0.3		0.8	V
I_{IH}	High Level Input Current	$V_{IN} = V_{CC}$	-10		10	μ A
I_{IL}	Low Level Input Current	$V_{IN} = GND$	75	94	124	μ A
R_{PU}	Pull-High Resistance			35		k Ω
RECEIVER SPECIFICATIONS						
V_{ID}	Differential Input Voltage Range	AC Coupled Differential Signal Below 1.25 Gb/s Above 1.25 Gbps Measured at input pins.	100 100		1750 1560	mV _{P-P} mV _{P-P}
V_{ICM}	Common Mode Voltage at Receiver Inputs	Measured at receiver inputs reference to ground.		1.5		V
R_{ITD}	Input Differential Termination	On-chip differential termination between IN+ or IN-.	84	100	116	Ω
R_{ITSE}	Input Termination (single-end)	On-chip termination IN+ or IN- to GND for frequency > 100 MHz.		50		Ω
DRIVER SPECIFICATIONS						
VO DB	Output Differential Voltage Swing without Pre-Emphasis	$R_L = 100\Omega \pm 1\%$ PRES_1=PRES_0=0 PREL_1=PREL_0=0 Driver pre-emphasis disabled. Running K28.7 pattern at 2.5 Gbps. See Figure 5 for test circuit.	1000	1200	1400	mV _{P-P}

Electrical Characteristics (Continued)

Over recommended operating supply and temperature ranges unless otherwise specified.

Symbol	Parameter	Conditions	Min	Typ (Note 2)	Max	Units
DRIVER SPECIFICATIONS						
V_{PE}	Output Pre-Emphasis Voltage Ratio $20 \cdot \log(VODPE/VODB)$	$R_L = 100\Omega \pm 1\%$ Running K28.7 pattern at 2.5 Gbps $PREx_{[1:0]}=00$ $PREx_{[1:0]}=01$ $PREx_{[1:0]}=10$ $PREx_{[1:0]}=11$ $x=S$ for switch side pre-emphasis control $x=L$ for line side pre-emphasis control See <i>Figure 1</i> on waveform. See <i>Figure 5</i> for test circuit.		0 -3 -6 -9		dB dB dB dB
t_{PE}	Pre-Emphasis Width	Tested at -9 dB pre-emphasis level, $PREx_{[1:0]}=11$ $x=S$ for switch side pre-emphasis control $x=L$ for line side pre-emphasis control See <i>Figure 4</i> on measurement condition.	125	188	400	ps
R_{OTSE}	Output Termination	On-chip termination from OUT+ or OUT- to V_{CC}	42	50	58	Ω
R_{OTD}	Output Differential Termination	On-chip differential termination between OUT+ and OUT-		100		Ω
ΔR_{OTSE}	Mis-Match in Output Termination Resistors	Mis-match in output terminations at OUT+ and OUT-			5	%
V_{OCM}	Output Common Mode Voltage		2.4		2.9	V
POWER DISSIPATION						
P_D	Power Dissipation	$V_{DD} = 3.465V$ All outputs terminated by $100\Omega \pm 1\%$. $PREL_{[1:0]}=0$, $PRES_{[1:0]}=0$ Running PRBS 2^7-1 pattern at 2.5 Gbps			1	W
AC CHARACTERISTICS						
t_R	Differential Low to High Transition Time	Measured with a clock-like pattern at 100 MHz, between 20% and 80% of the differential output voltage. Pre-emphasis disabled. Transition time is measured with fixture as shown in <i>Figure 5</i> , adjusted to reflect the transition time at the output pins.		80		ps
t_F	Differential High to Low Transition Time			80		ps
t_{PLH}	Differential Low to High Propagation Delay	Measured at 50% differential voltage from input to output.		0.5	2	ns
t_{PHL}	Differential High to Low Propagation Delay			0.5	2	ns
t_{SKP}	Pulse Skew	$ t_{PHL} - t_{PLH} $			20	ps
t_{SKO}	Output Skew (Note 7)	Difference in propagation delay between two outputs in the same device.			200	ps
t_{SKPP}	Part-to-Part Skew	Difference in propagation delay between the same output from devices operating under identical conditions.			500	ps

Electrical Characteristics (Continued)

Over recommended operating supply and temperature ranges unless otherwise specified.

Symbol	Parameter	Conditions	Min	Typ (Note 2)	Max	Units
AC CHARACTERISTICS						
t_{SM}	Mux Switch Time	Measured from V_{IH} or V_{IL} of the mux-control or loopback control to 50% of the valid differential output.		1.8	6	ns
RJ	Device Random Jitter (Note 5)	See <i>Figure 5</i> for test circuit. Alternating-1-0 pattern. Pre-emphasis disabled. At 1.25 Gbps At 2.5 Gbps			2 2	psrms psrms
DJ	Device Deterministic Jitter (Note 6)	See <i>Figure 5</i> for test circuit. Pre-emphasis disabled. Between 0.8 and 2.5 Gbps with PRBS7 pattern for DS25MB200 @ 0°C–85°C			30	Psp
DR_{MAX}	Maximum Data Rate	Tested with alternating-1-0 pattern	2.5			Gbps

Note 1: “Absolute Maximum Ratings” are the ratings beyond which the safety of the device cannot be guaranteed. They are not meant to imply that the device should be operated at these limits.

Note 2: Typical parameters measured at $V_{CC} = 3.3V$, $T_A = 25^\circ C$. They are for reference purposes and are not production-tested.

Note 3: IN+ and IN– are generic names refer to one of the many pairs of complimentary inputs of the DS25MB200. OUT+ and OUT– are generic names refer to one of the many pairs of the complimentary outputs of the DS25MB200. Differential input voltage V_{ID} is defined as $IIN+ - IN-$. Differential output voltage V_{OD} is defined as $IOUT+ - OUT-$.

Note 4: K28.7 pattern is a 10-bit repeating pattern of K28.7 code group {001111 1000}

K28.5 pattern is a 20-bit repeating pattern of +K28.5 and –K28.5 code groups {110000 0101 001111 1010}

Note 5: Device output random jitter is a measurement of the random jitter contribution from the device. It is derived by the equation $\sqrt{RJ_{OUT}^2 - RJ_{IN}^2}$, where RJ_{OUT} is the total random jitter measured at the output of the device in psrms, RJ_{IN} is the random jitter of the pattern generator driving the device.

Note 6: Device output deterministic jitter is a measurement of the deterministic jitter contribution from the device. It is derived by the equation $(DJ_{OUT} - DJ_{IN})$, where DJ_{OUT} is the total peak-to-peak deterministic jitter measured at the output of the device in pspp, DJ_{IN} is the peak-to-peak deterministic jitter of the pattern generator driving the device.

Note 7: t_{SKO} is the magnitude difference in the propagation delays among data paths between switch A and switch B of the same port and similar data paths between port 0 and port 1. An example is the output skew among data paths from SIA_0± to LO_0±, SIB_0± to LO_0±, SIA_1± to LO_1± and SIB_1± to LO_1±. Another example is the output skew among data paths from LI_0± to SOA_0±, LI_0± to SOB_0±, LI_1± to SOA_1± and LI_1± to SOB_1±. t_{SKO} also refers to the delay skew of the loopback paths of the same port and between similar data paths between port 0 and port 1. An example is the output skew among data paths SIA_0± to SOA_0±, SIB_0± to SOB_0±, SIA_1± to SOA_1± and SIB_1± to SOB_1±.

Timing Diagrams

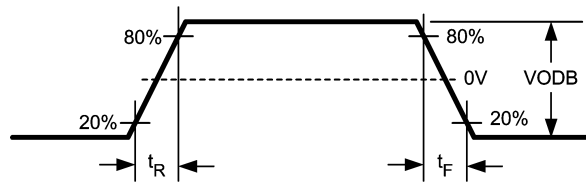

20182336

FIGURE 2. Driver Output Transition Time

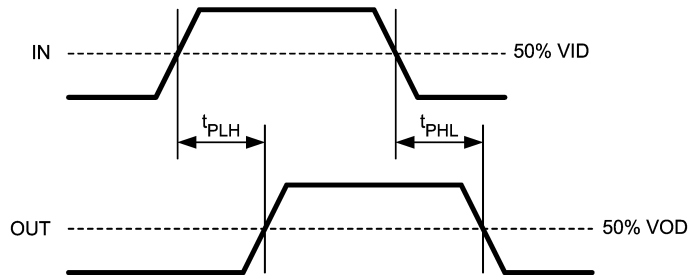

20182335

FIGURE 3. Propagation Delay from Input to Output

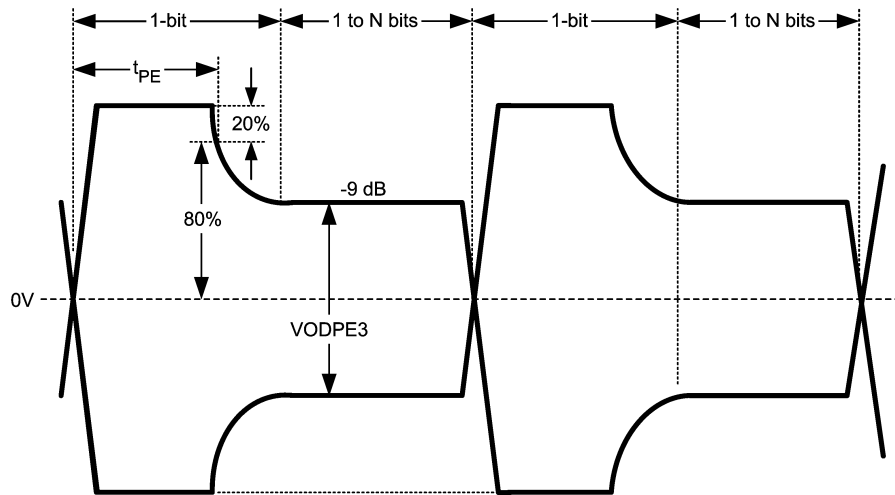

20182339

FIGURE 4. Test Condition for Output Pre-Emphasis Duration

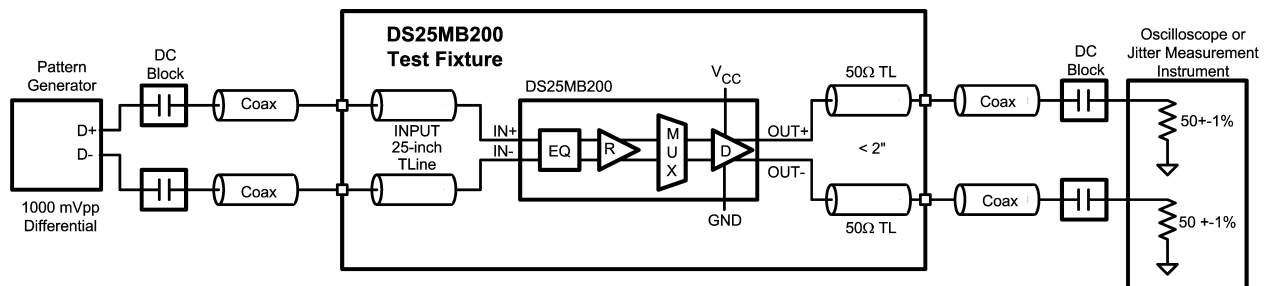

20182334

FIGURE 5. AC Test Circuit

Timing Diagrams (Continued)

The DS25MB200 input equalizer provides equalization to compensate about 5 dB of transmission loss from a short backplane transmission line. For characterization purposes, a 25-inch FR4 coupled micro-strip board trace is used in place of the short backplane link. The 25-inch microstrip board trace has approximately 5 dB of attenuation between

375 MHz and 1.875 GHz, representing closely the transmission loss of the short backplane transmission line. The 25-inch microstrip is connected between the pattern generator and the differential inputs of the DS25MB200 for AC measurements.

Trace Length	Finished Trace Width W	Separation between Traces	Dielectric Height H	Dielectric Constant ϵ_R	Loss Tangent
25 inches	8.5 mil	11.5 mil	6 mil	3.8	0.022

Application Information

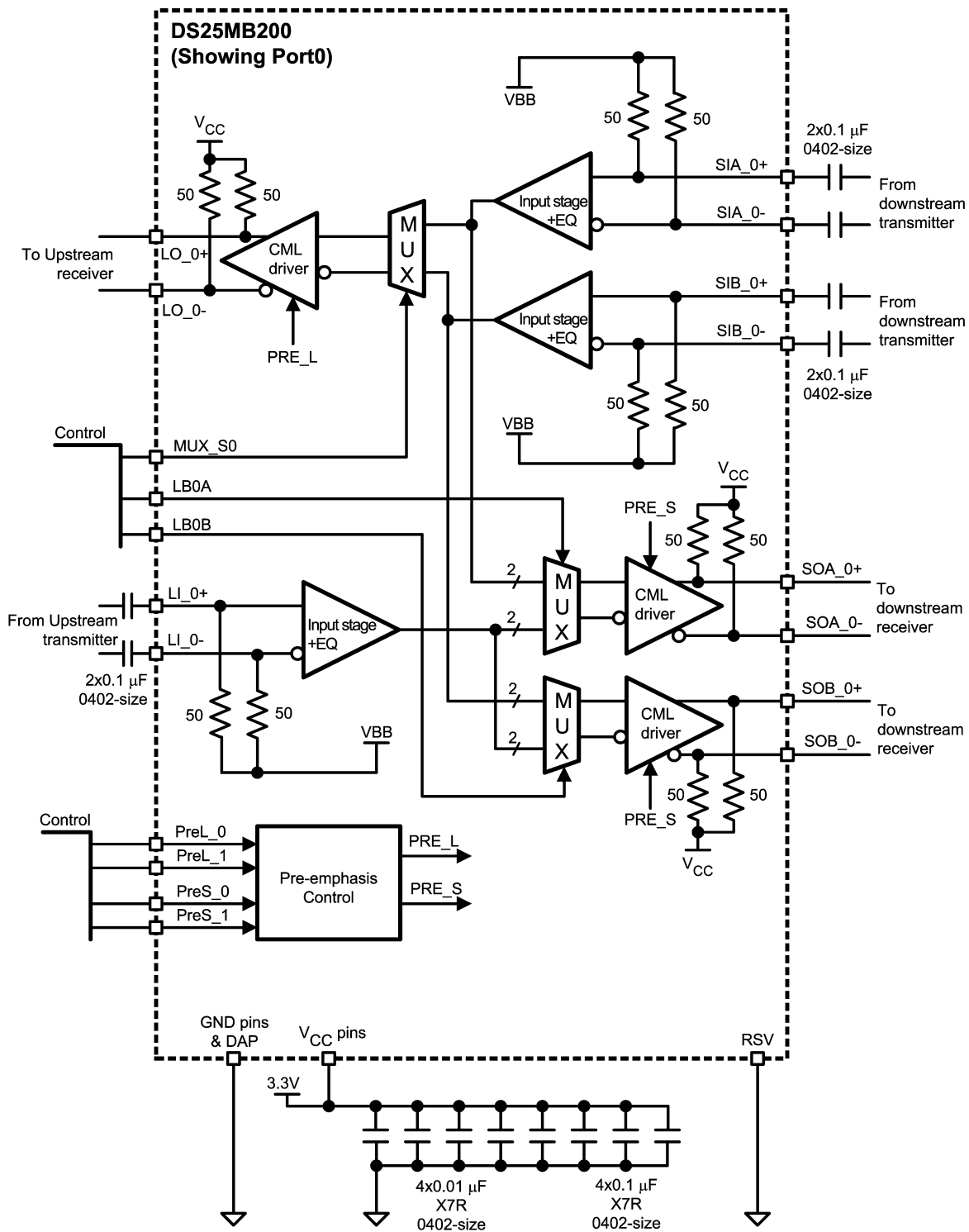

20182340

FIGURE 6. Application Diagram (showing data paths of port 0)

Physical Dimensions inches (millimeters) unless otherwise noted

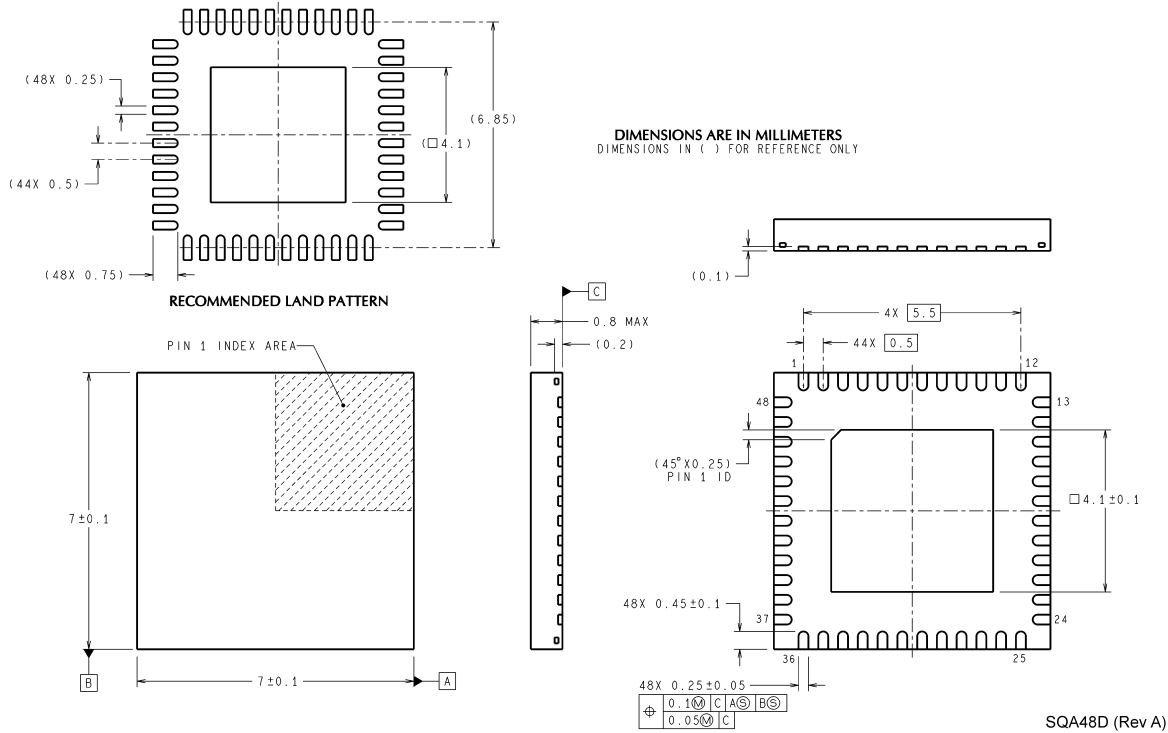

LLP-48 Package
Order Number DS25MB200TSQ
NS Package Number NSQAV48

National does not assume any responsibility for use of any circuitry described, no circuit patent licenses are implied and National reserves the right at any time without notice to change said circuitry and specifications.

For the most current product information visit us at www.national.com.

LIFE SUPPORT POLICY

NATIONAL'S PRODUCTS ARE NOT AUTHORIZED FOR USE AS CRITICAL COMPONENTS IN LIFE SUPPORT DEVICES OR SYSTEMS WITHOUT THE EXPRESS WRITTEN APPROVAL OF THE PRESIDENT AND GENERAL COUNSEL OF NATIONAL SEMICONDUCTOR CORPORATION. As used herein:

1. Life support devices or systems are devices or systems which, (a) are intended for surgical implant into the body, or (b) support or sustain life, and whose failure to perform when properly used in accordance with instructions for use provided in the labeling, can be reasonably expected to result in a significant injury to the user.
2. A critical component is any component of a life support device or system whose failure to perform can be reasonably expected to cause the failure of the life support device or system, or to affect its safety or effectiveness.

BANNED SUBSTANCE COMPLIANCE

National Semiconductor manufactures products and uses packing materials that meet the provisions of the Customer Products Stewardship Specification (CSP-9-111C2) and the Banned Substances and Materials of Interest Specification (CSP-9-111S2) and contain no "Banned Substances" as defined in CSP-9-111S2.

Leadfree products are RoHS compliant.



National Semiconductor
Americas Customer
Support Center
 Email: new.feedback@nsc.com
 Tel: 1-800-272-9959

National Semiconductor
Europe Customer Support Center
 Fax: +49 (0) 180-530 85 86
 Email: europe.support@nsc.com
 Deutsch Tel: +49 (0) 69 9508 6208
 English Tel: +44 (0) 870 24 0 2171
 Français Tel: +33 (0) 1 41 91 8790

National Semiconductor
Asia Pacific Customer
Support Center
 Email: ap.support@nsc.com

National Semiconductor
Japan Customer Support Center
 Fax: 81-3-5639-7507
 Email: jpn.feedback@nsc.com
 Tel: 81-3-5639-7560