

Basic Switch

D2MQ

Subminiature Basic Switch

- Super compact switch weighing only 0.3 g. Ideal for reducing equipment weight
- Angle terminal allows operation from the side when mounted to a PCB
- Despite its compact size, the snap action mechanism gives it superior electrical characteristics
- Silver-plated contact. Gold-plated contact also available for loads under 50 mA
- Ideal for use on equipment with stringent space and reliability requirements, such as in compact audio equipment, optical devices, and communications equipment

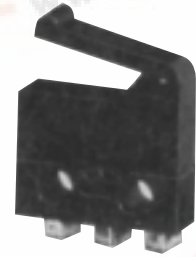

Ordering Information



Actuator	Contact	Part Number		
		Straight Terminal	Left-angle Terminal	Right-angle Terminal
Pin plunger	Silver-plated (Ag-P)	D2MQ-1	D2MQ-1-TL	D2MQ-1-TR
	Gold-plated (Au-P)	D2MQ-1-105	—	—
Leaf lever	Silver-plated (Ag-P)	D2MQ-1L	D2MQ-1L-TL	D2MQ-1L-TR
	Gold-plated (Au-P)	D2MQ-1L-105	—	—

Note: The angle of the terminal illustration above is from the side of the arrow shown on the right.

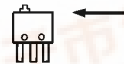

■ CONTACT FORM

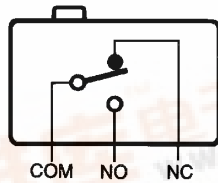

Specifications

Ratings	
Electrical ratings	Ag-Plated contact: 50 to 500 mA, 30 VDC (resistive load) Au-Plated contact: 5 to 50 mA, 30 VDC (resistive load)
Inrush current	NC: 0.5 A max. (Ag-P), 0.05 A max. (Au-P) NO: 0.5 A max. (Ag-P), 0.05 A max. (Au-P)



Characteristics

Operating speed		0.1 mm to 0.5 m/second (0.004 to 19.7 in/second) at pin plunger
Operating frequency	Mechanical	60 operations per minute
	Electrical	20 operations per minute
Contact resistance		100 mΩ max. (initial)
Insulation resistance		100 MΩ min. (at 250 VDC)
Dielectric strength		500 VAC, 50/60 Hz for 1 minute between terminals of same polarity 500 VAC, 50/60 Hz for 1 minute between current-carrying metal part and ground
Vibration	Malfunction durability	10 to 55 Hz, 1.5 mm double amplitude
Shock	Mechanical durability	1,000 m/s ² min. (approx. 100 g min.)
	Malfunction durability	300 m/s ² min. (approx. 30 g min.)
Ambient temperature	Operating	-15° to 70°C (with not condensation)
Humidity		35% to 85% RH
Service life	Mechanical	30,000 operations min. (at full OT value)
	Electrical	10,000 operations min. (at full OT value)
Weight		Approx. 0.3 g

Note: Data shown are of initial value.

CHARACTERISTIC DATA

Mechanical service life

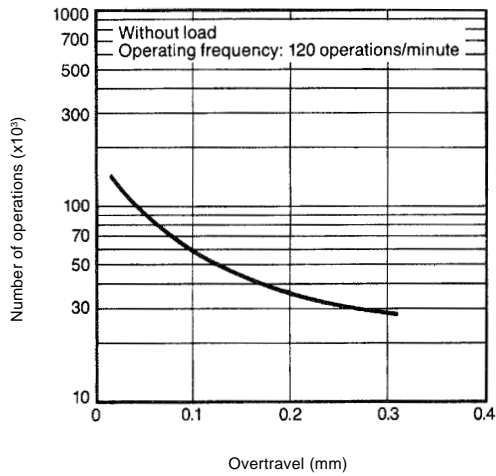

Electrical service life

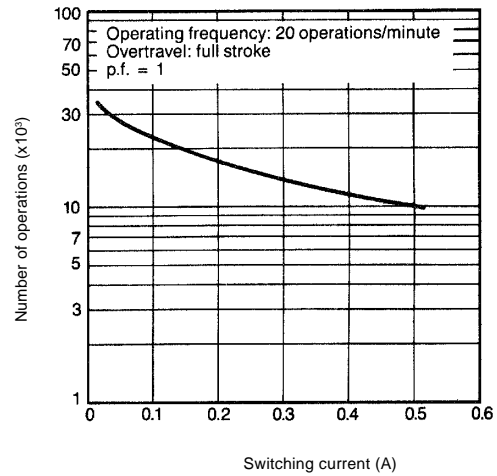

Dimensions

Unit: mm (inch)

Pin Plunger

D2MQ-1 (Straight terminal)

D2MQ-1-TL (Left-angle terminal)

D2MQ-1-TR (Right-angle terminal)

D2MQ-1-105 (Straight terminal)

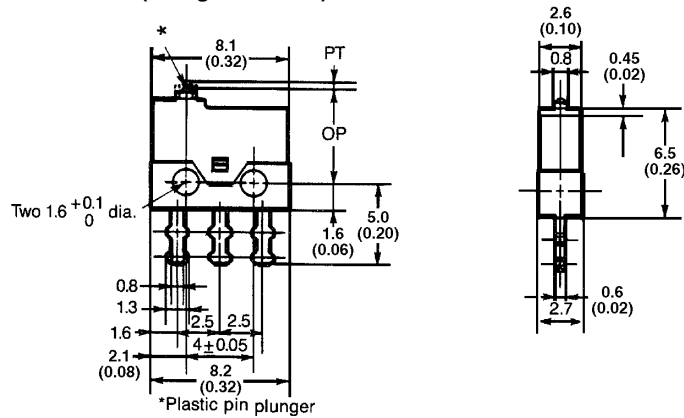

Operating characteristics	
OF max.	120 g
RF min.	20 g
PT max.	0.4 mm (0.016 in)
OT min.	0.1 mm (0.004 in)
MD max.	0.1 mm (0.004 in)
OP	5.7 ± 0.2 mm (0.22 ± 0.01 in)

Leaf lever

D2MQ-1L (Straight terminal)

D2MQ-1L-TL (Left-angle terminal)

D2MQ-1L-TR (Right-angle terminal)

D2MQ-1L-105 (Straight terminal)

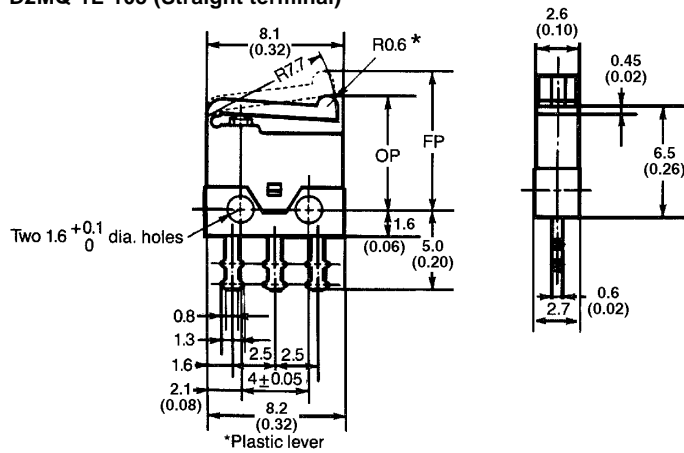

Operating characteristics	
OF max.	60 g
RF min.	8 g
PT max.	2.4 mm (0.09 in)
OT min.	0.3 mm (0.01 in)
MD max.	0.7 mm (0.03 in)
FP* max.	9.6 mm (0.38 in)
OP	6.7 ± 0.5 mm (0.26 ± 0.02 in)

*Free position

TERMINALS

Straight terminal

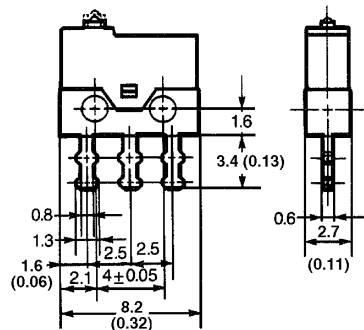

Left-angle terminal

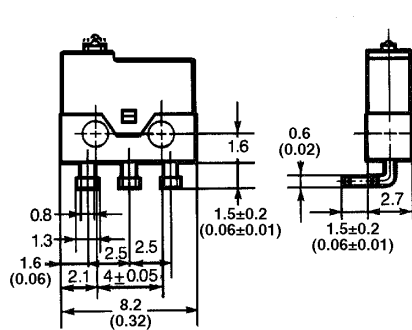

Right-angle terminal

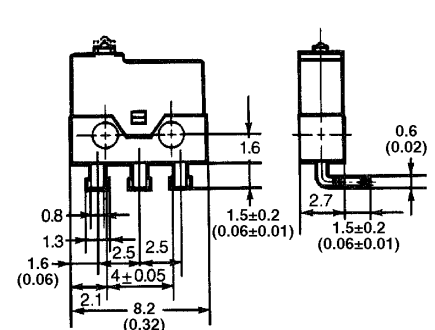

Precautions

■ MOUNTING

Mount firmly using M1.4 screws and 1 kg-cm tightening torque.

Mounting hole matching dimensions

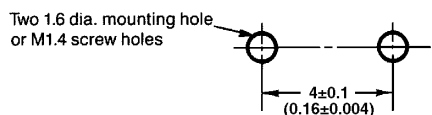

When mounting onto a metal body, always install a separator between the switch and the mounting panel.

Design the insulation separator (made up of hard material) into the shape shown below.

Separator shape

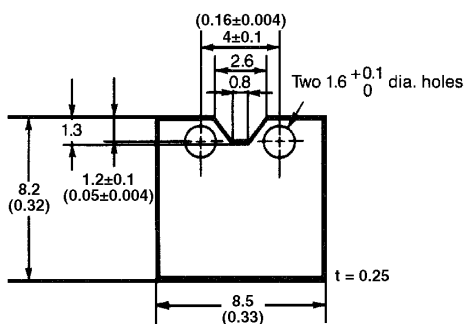

■ SOLDERING

Holding the switch at the free position, solder the lead wire to its terminal within 3 seconds, using a soldering iron rated at less than 15 W with a tip temperature of less than 280°C. Excess wattage or prolonged heating can deteriorate the electrical characteristics of the switch.

■ OPERATION

Set the operating force of the pushbutton and leaf lever at less than twice the OF standard value.

Always make the OT value larger than the specification value.

Do not change the operating position of the actuator.

Do not operate at extremely slow speed; also do not use the switch with its pushbutton located between the free position and the operating position.

Mount the pin pushbutton type in such a way that the stroke of the pushbutton and the stroke of the operating control overlap on a vertical line.

Do not operate the switch roughly as it may deteriorate the functions of the switch.

Do not apply excessive force to the actuator of the leaf lever type along its operating direction, opposite to its operating direction, or in the lateral direction.

OMRON

Omron Europe B.V. EMA-ISD, tel:+31 23 5681390, fax:+31 23 5681397, <http://www.eu.omron.com/ema>