



Inductive Proximity Sensor

E2CA

Linear Output Proximity Sensor with High-accuracy Resolution

- Resolution is 0.05% of the maximum sensing distance. The model with a sensing distance of 1.2 mm ensures a resolution of 0.6 μm .
- Models with response frequencies ranging from 10 to 3 kHz are available.
- The M30-size model ensures a sensing distance of 10 mm.
- Satisfies IEC IP67 requirements, thus detecting the displacement of metal objects without being influenced by water and oil spray.
- The E2CA has a standard linear output of 4 to 20 mA and connects to the Linear Discrimination Unit, Digital Panel Meter, and I/O Unit of the Programmable Controller.
- The E2CA's compact amplifier can be plugged into surface mounting sockets thus greatly reducing wiring effort and ensuring easy mounting.



Ordering Information

Shield	Size	Sensing distance (Sn)	Response frequency		Sensor Unit	Amplifier Unit	
			Linear output	Switching output		DC	AC
Shielded	M8	0.3 to 1.5 mm	10 kHz	1 kHz	E2CA-XIR5A	E2CA-AL4C	E2CA-AN4C
	M12	0.4 to 2 mm	10 kHz	800 Hz	E2CA-X2A	E2CA-AL4D	E2CA-AN4D
	M18	1 to 5 mm	5 kHz	350 Hz	E2CA-X5A	E2CA-AL4E	E2CA-AN4E
	M30	2 to 10 mm	3 kHz	100 Hz	E2CA-X10A	E2CA-AL4F	E2CA-AN4F

Application Examples

Detection of Metals on Other Metals

Counts the number of gear teeth.
Detects mounting screws, rivets, and soldering condition

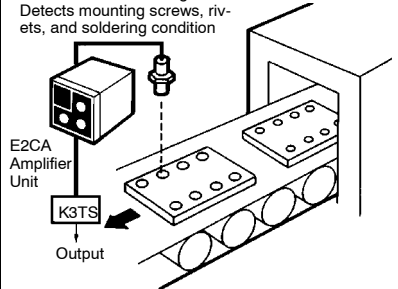

Detection of Loosened Screws

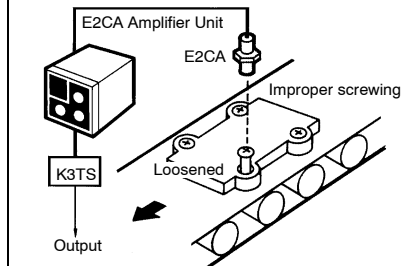

Discrimination of Materials

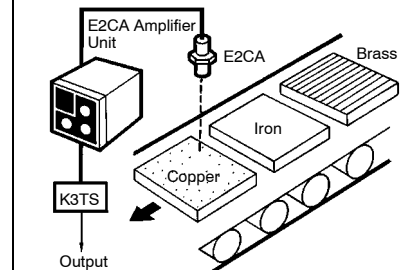

Measurement of Sheet Angles

Measures leaned press molds and elevated boards

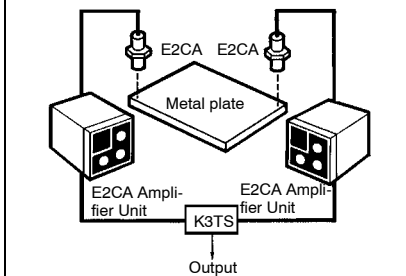

Measurement of Sheet Thickness

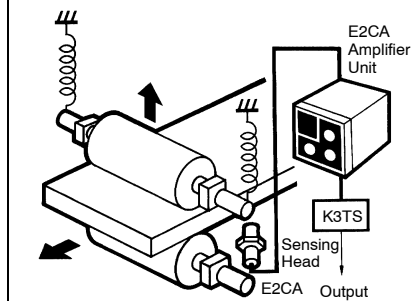

Measurement of External Dimensions

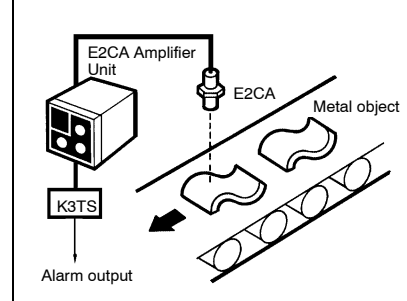

Discrimination of Shapes

Detects top and bottom sides of metal caps
and surface and back sides of nuts

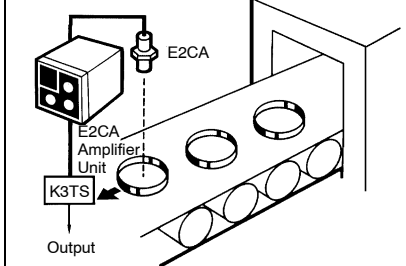

Measurement of Object Deformations

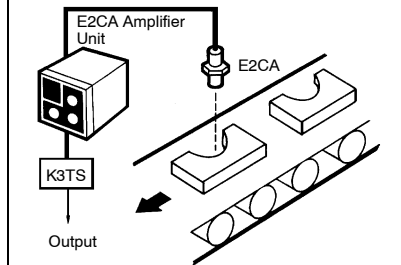

Specifications

Item		Sensor model		E2CA-X1R5A		E2CA-X2A	
		Amplifier model		E2CA-AN4C	E2CA-AL4C	E2CA-AN4D	E2CA-AL4D
Supply voltage (operating voltage range)		100 to 240 VAC 50/60 Hz (90 to 264 VAC)		12 to 24 VDC (10 to 30 VDC), ripple (p-p): 10% max.		100 to 240 VAC 50/60 Hz (90 to 264 VAC)	
Current consumption		60 mA max.		70 mA max.		60 mA max.	
Sensing object		Ferrous metal					
Sensing range (with standard sensing object)		0.3 to 1.5 mm (8 x 8 x 1 mm iron)		0.4 to 2 mm (12 x 12 x 1 mm iron)			
Linear output characteristics		Resolution		0.05% FS			
		Linearity		±2% FS		±1.5% FS	
		Response frequency (see note 1)		10 kHz (-1 dB)		10 kHz (-1 dB)	
Switching output characteristics		Differential travel		2% to 5% of rated sensing distance			
		Response frequency (see note 2)		1 kHz		800 Hz	
Sensitivity adjustment function		Sensitivity adjustment (switching output)		Adjustments of switching output within sensing range			
		Linear output current adjustment		4 mA		4-mA adjustment at 20% of rated sensing distance	
				20 mA		20-mA adjustment at rated sensing distance	
Output		Linear output (see note 3)		4 to 20 mA (with permissible load resistance of 0 to 300 Ω)			
		Switching output		100 mA max. transistor photocoupler output at 40 VDC with max. residual voltage of 2 V			
Switching output mode		Normally open or normally closed (selectable with selector on front panel)					
Cord length compensation		3 or 5 m (selectable with selector on front panel)					
Indicators		POWER, SPAN (linear range), and OPER (switching output) indicators					
Ambient temperature		Operating: -25°C to 70°C (Sensor) and -10°C to 55°C (Amplifier) with no icing					
Ambient humidity		Operating: 35% to 95% (Sensor) and 35% to 85% (Amplifier)					
Temperature influence		±10% FS max. of linear output current at 23°C in the rated ambient operating temperature range of the Sensor and Amplifier Units					
Voltage influence		DC power supply model: ±0.5% FS max. of linear output current at a voltage between 80% and 120% of the rated power supply voltage AC power supply model: ±0.5% FS max. of linear output current at a voltage between 90% and 110% of the rated power supply voltage					
Insulation resistance		50 MΩ min. (at 500 VDC) between the case and current carry parts					
Dielectric strength		DC power supply model: 1,000 VAC (50/60 Hz) for 1 min between current carry parts and case AC power supply model: 1,500 VAC (50/60 Hz) for 1 min between current carry parts and case					
Vibration resistance		Sensor (destruction): 10 to 55 Hz, 1.5-mm double amplitude for 2 hours each in X, Y, and Z directions Amplifier (destruction): 10 to 25 Hz, 2-mm double amplitude for 2 hours each in X, Y, and Z directions					
Shock resistance		Sensor (destruction): 500 m/s ² (approx. 50G) 3 times each in X, Y, and Z directions Amplifier (destruction): 100 m/s ² (approx. 10G) 3 times each in X, Y, and Z directions					
Degree of protection		Sensor: IEC60529 IP67 (JEM IP67g waterproof and oil-proof)					
Cord length		Sensor: 2-conductor, 3-m-long (standard length) or 5-m-long shielded cord					
Weight (see note 4)		Sensor		Approx. 40 g			
		Amplifier		Approx. 250 g		Approx. 140 g	
Material		Case		Brass			
		Sensing surface		ABS resin			
		Cord		Polyethylene			

Sensor model		E2CA-X5A		E2CA-X10A	
Item	Amplifier model	E2CA-AN4E	E2CA-AL4E	E2CA-AN4F	E2CA-AL4F
Supply voltage (operating voltage range)		100 to 240 VAC 50/60 Hz (90 to 264 VAC)	12 to 24 VDC (10 to 30 VDC), ripple (p-p): 10% max.	100 to 240 VAC 50/60 Hz (90 to 264 VAC)	12 to 24 VDC (10 to 30 VDC), ripple (p-p): 10% max.
Current consumption		60 mA max.	70 mA max.	60 mA max.	70 mA max.
Sensing object		Ferrous metal			
Sensing range (with standard sensing object)		1 to 5 mm (18 x 18 x 1 mm iron)		2 to 10 mm (30 x 30 x 1 mm iron)	
Linear output characteristics	Resolution	0.05% FS			
	Linearity	±1.5% FS		±2% FS	
	Response frequency (see note 1)	5 kHz (-1 dB)		3 kHz (-1 dB)	
Switching output characteristics	Differential travel	2% to 5% of rated sensing distance			
	Response frequency (see note 2)	350 Hz		100 Hz	
Sensitivity adjustment function	Sensitivity adjustment (switching output)		Adjustments of switching output within sensing range		
	Linear output current adjustment	4 mA	4-mA adjustment at 20% of rated sensing distance		
		20 mA	20-mA adjustment at rated sensing distance		
Output	Linear output (see note 3)		4 to 20 mA (with permissible load resistance of 0 to 300 Ω)		
	Switching output		100 mA max. transistor photocoupler output at 40 VDC with max. residual voltage of 2 V		
Switching output mode		Normally open or normally closed (selectable with selector on front panel)			
Cord length compensation		3 or 5 m (selectable with selector on front panel)			
Indicators		POWER, SPAN (linear range), and OPER (switching output) indicators			
Ambient temperature		Operating: -25°C to 70°C (Sensor) and -10°C to 55°C (Amplifier) with no icing			
Ambient humidity		Operating: 35% to 95% (Sensor) and 35% to 85% (Amplifier)			
Temperature influence		±10% FS max. of sensing distance at 23°C in the rated ambient operating temperature range of -10°C and 40°C			
Voltage influence		DC power supply model: ±0.5% FS max. of linear output current at a voltage between 80% and 120% of the rated power supply voltage AC power supply model: ±0.5% FS max. of linear output current at a voltage between 90% and 110% of the rated power supply voltage			
Insulation resistance		50 MΩ min. (at 500 VDC) between the case and current carry parts			
Dielectric strength		DC power supply model: 1,000 VAC (50/60 Hz) for 1 min between current carry parts and case AC power supply model: 1,500 VAC (50/60 Hz) for 1 min between current carry parts and case			
Vibration resistance		Sensor (destruction): 10 to 55 Hz, 1.5-mm double amplitude for 2 hours each in X, Y, and Z directions Amplifier (destruction): 10 to 25 Hz, 2-mm double amplitude for 2 hours each in X, Y, and Z directions			
Shock resistance		Sensor (destruction): 500 m/s ² (approx. 50G) 3 times each in X, Y, and Z directions Amplifier (destruction): 100 m/s ² (approx. 10G) 3 times each in X, Y, and Z directions			
Degree of Protection		Sensor: IEC60529 IP67 (JEM IP67g waterproof and oil-proof)			
Cord length		Sensor: 2-conductor, 3-m-long (standard length) or 5-m-long shielded cord			
Weight (see note 4)	Sensor		Approx. 60 g		Approx. 160 g
	Amplifier		Approx. 250 g	Approx. 140 g	Approx. 250 g
Material	Case		Brass		
	Sensing surface		ABS resin		
	Cord		Polyethylene		

- Note:**
1. This is a frequency decreasing the level of linear output current by 1 dB.
 2. This is a response frequency measured in accordance with CENELEC standards.
 3. The maximum load impedance of the E2CA-AL4 is 150 Ω at a supply voltage of 12 V.
 4. The weight includes the 3-m-long cord. The weights of the Amplifiers do not include connecting sockets.

Engineering Data

Sensing Distance vs. Output Current (Typical)

E2CA-X1R5A

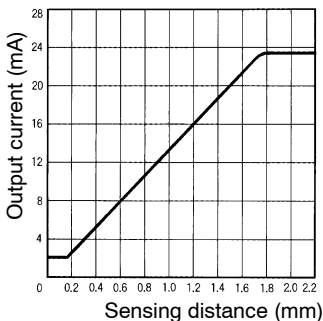

E2CA-X2A

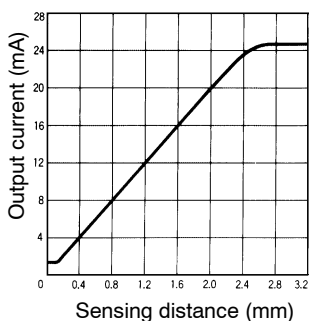

E2CA-X5A

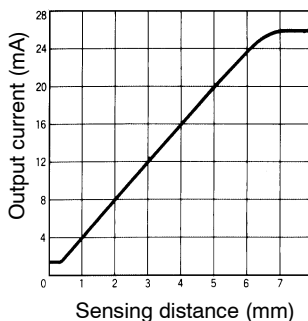

E2CA-X10A

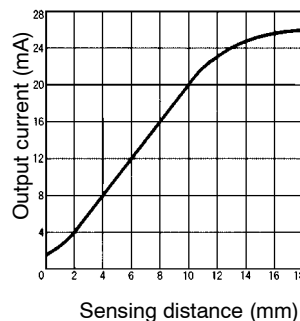

Sensing Object Size vs. Linearity (Typical)

E2CA-X1R5A

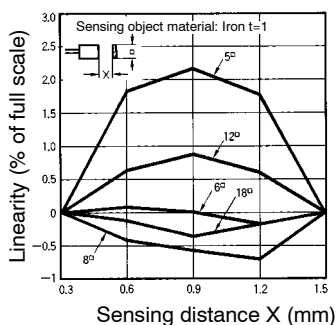

E2CA-X2A

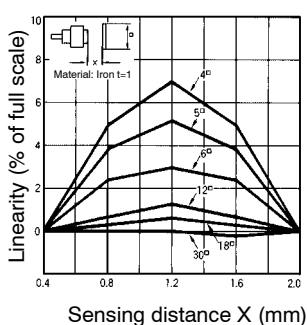

E2CA-X5A

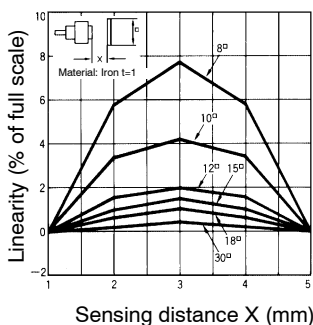

E2CA-X10A

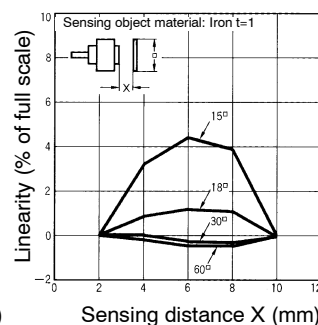

Column Diameter vs. Linearity (Typical)

E2CA-X1R5A

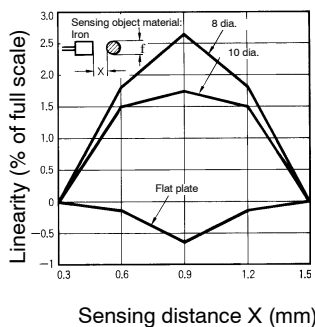

E2CA-X2A

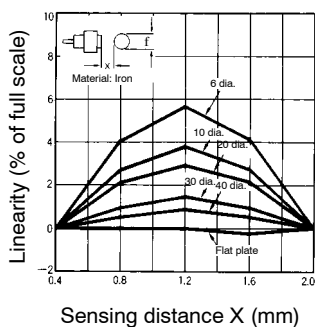

E2CA-X5A

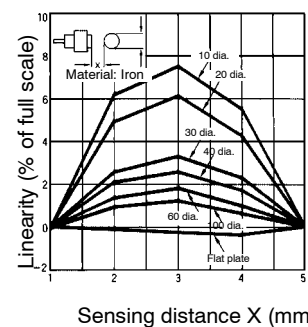

E2CA-X10A

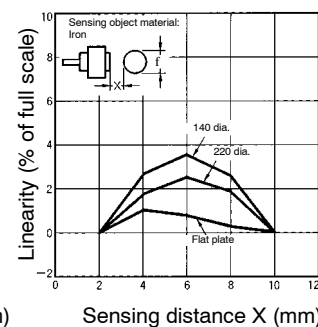

Nomenclature

Selector and Adjuster Settings

(1) Operation Mode Selector

<p>OUTPUT</p> <p>NO <input type="checkbox"/> NC</p>	<p>The switching output transistor turns ON when there is sensing object detection.</p>
<p>OUTPUT</p> <p>NO <input type="checkbox"/> NC</p>	<p>The switching output transistor turns ON when there is no sensing object detection.</p>

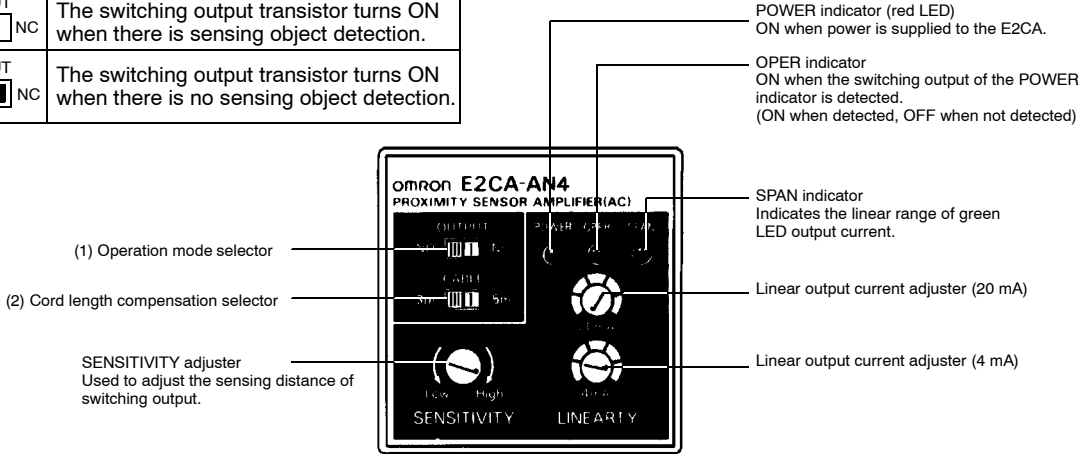

(2) Cord Length Compensation Selector



Set the selector to 3 m or 5 m according to the length of the Sensor cord in use.

<p>CABLE</p> <p>3 m <input type="checkbox"/> 5 m</p>	<p>A cord length of 3 m is selected.</p>
<p>CABLE</p> <p>3 m <input type="checkbox"/> 5 m</p>	<p>A cord length of 5 m is selected.</p>

Linear Output Adjustment (LINEARITY Adjuster)

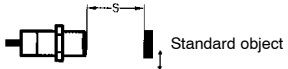

Step	1	2	3	Remarks
Positioning	---	<p>20% of rated sensing distance</p> <p>Standard object</p>	<p>Rated sensing distance</p> <p>Standard object</p>	---
LINEARITY adjuster	---	<p>4 mA</p>	<p>20 mA</p>	---
Adjustment procedure	<p>Connect an ammeter across terminals 1 and 2.</p> <p>E2CA-A□4□ Amplifier Unit P2CF-11 Front-connecting Socket</p> <p>Note: This illustration shows the Sensor Unit connected to the Amplifier Unit with the P2CF-11 Front-connecting Socket mounted.</p>	<p>Place the standard object at 20% of the rated sensing distance away from the Sensor Unit. Turn the 4 mA LINEARITY adjuster slowly clockwise (the output current is increased) or counterclockwise (the output current is decreased) to set the output current to 4 mA. (SPAN indicator is ON.)</p>	<p>Fasten the standard object at the rated sensing distance. Turn the 20-mA LINEARITY adjuster slowly clockwise (the output current is increased) or counterclockwise (the output current is decreased) to set the output current to 20 mA. (SPAN indicator is ON.)</p>	<p>To further improve the adjustment accuracy, set again the position of the standard object in the order of steps 2 and 3. Perform minute adjustment of the output current.</p>

Sensitivity (Distance) Adjustment

Detecting condition	Standard target (See Note at below right.) 
SENSITIVITY adjuster	
Adjustment procedure	Place the standard object at the specified position. Slowly turn the SENSITIVITY adjuster clockwise (toward "High") and stop it when the OPER. indicator illuminates. Move the object to confirm that the OPER. indicator is ON when the object is at the specified position and that it is OFF when the object is moved away from that position.

Compensation of Cord Length Difference

Set the CABLE selector to the required position according to the length of the cord being used (3 m or 5 m).

CABLE 3 m  5 m	3-m cord
CABLE 3 m  5 m	5-m cord

Operation

Output Circuit

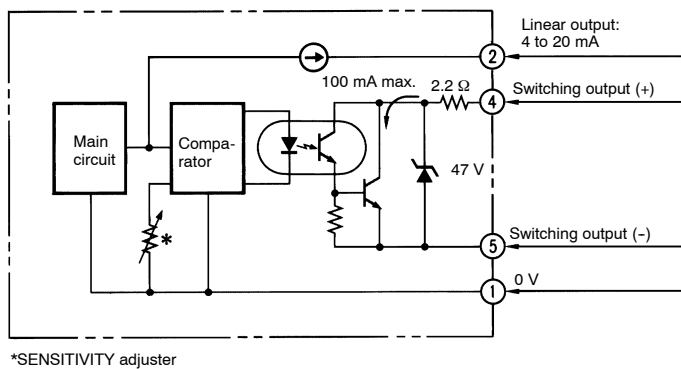

Timing Chart

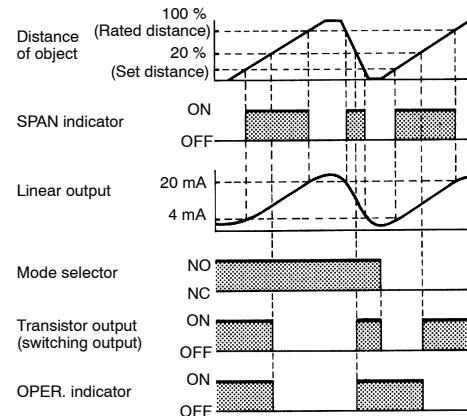

Connections

Connections between Sensor Units and Amplifier Units

E2CA-AL4□+Sensor Unit

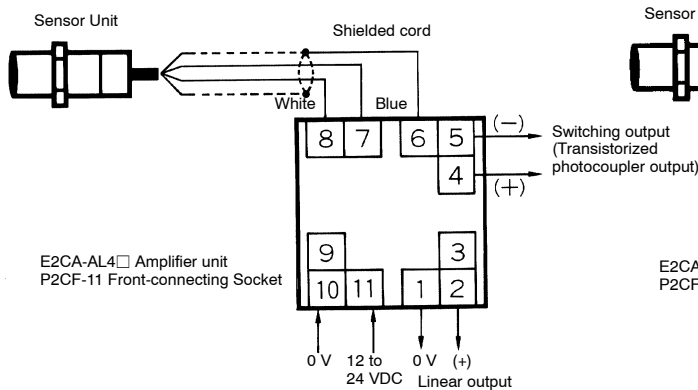

E2CA-AN4□+Sensor Unit

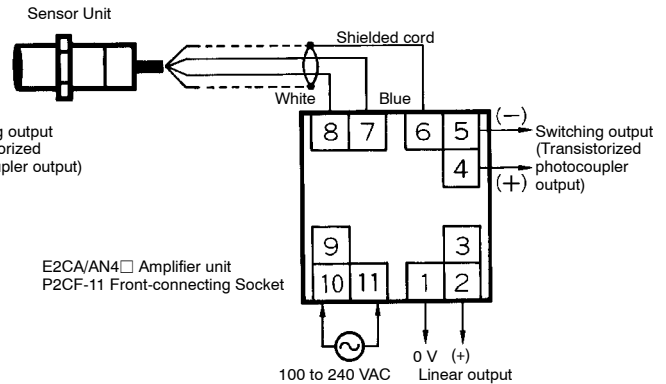

Note: The above illustrations show the terminal arrangement viewed from the rear of the socket, which is coupled to the Amplifier Unit.

**Connection of Resistive Load:
E2CA-AN4□+Sensor Unit**

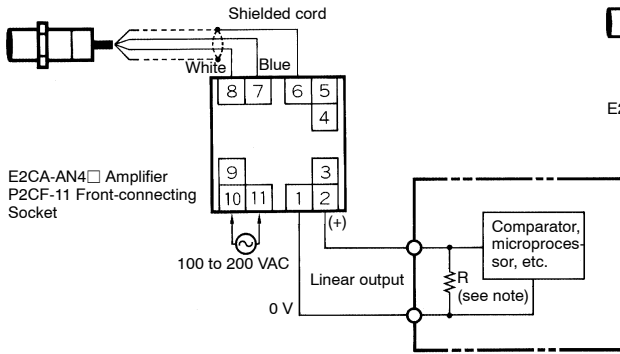

Note: Resistance R when E2CA-AL4 is used: 300 Ω max. at 24 V/150 Ω max. at 12 V
Resistance R when E2CA-AN4 is used: 300 Ω max.

Connection to Z4W-DD1C

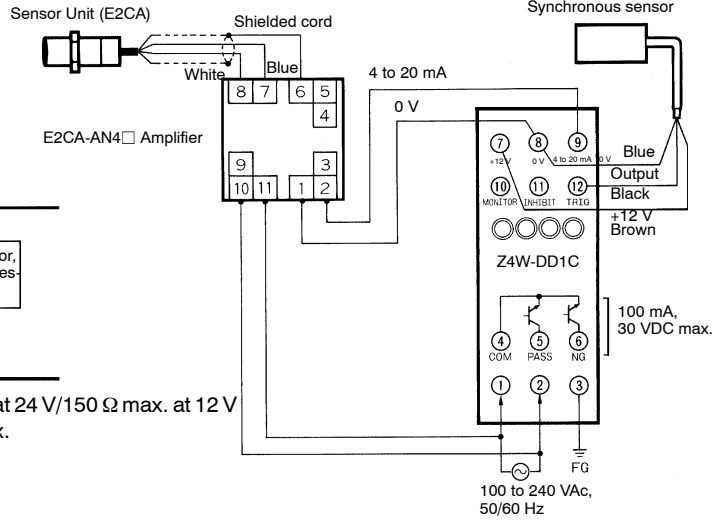

Connection to K3TS-SD12

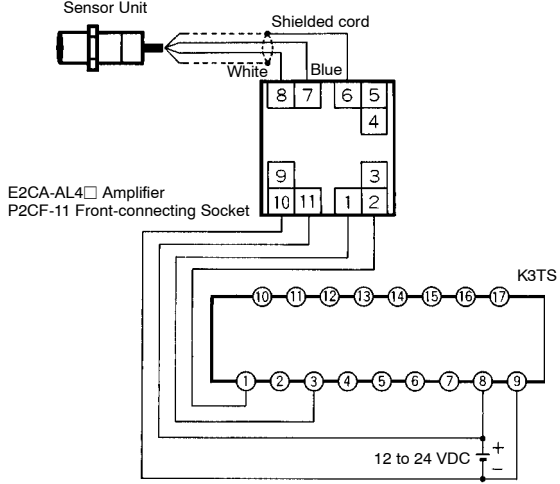

Connection to K3TX-AD22

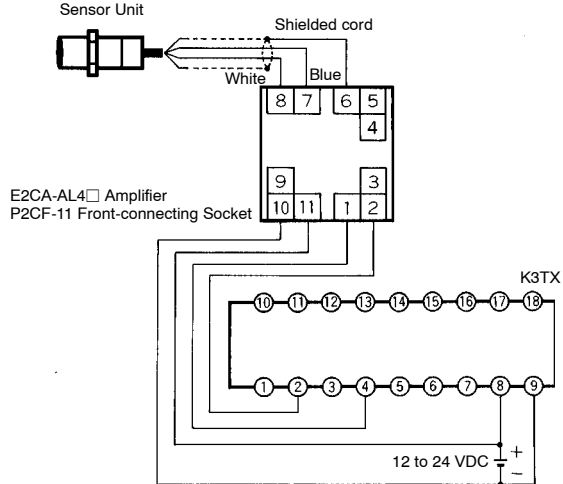

QCM1 Linear Sensor Interface Unit

Connection to QCM1-LSE

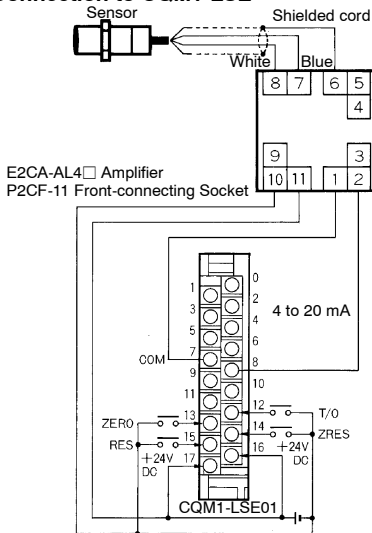

Dimensions

Note: All units are in millimeters unless otherwise indicated.

Sensor Units

E2CA-X1R5A

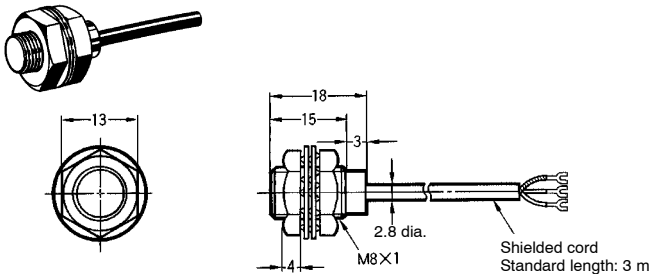

E2CA-X2A

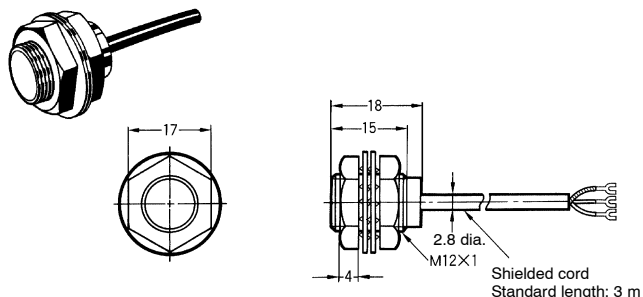

E2CA-X5A

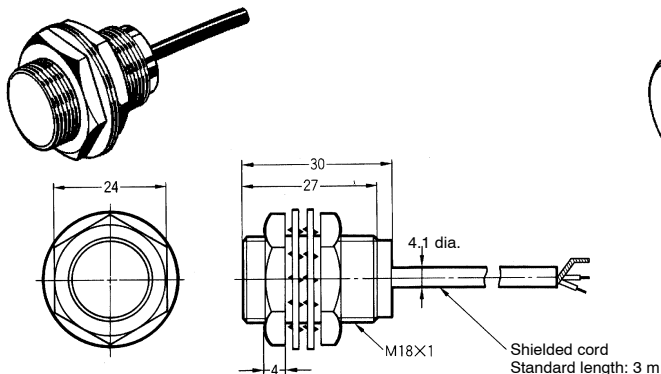

E2CA-X10A

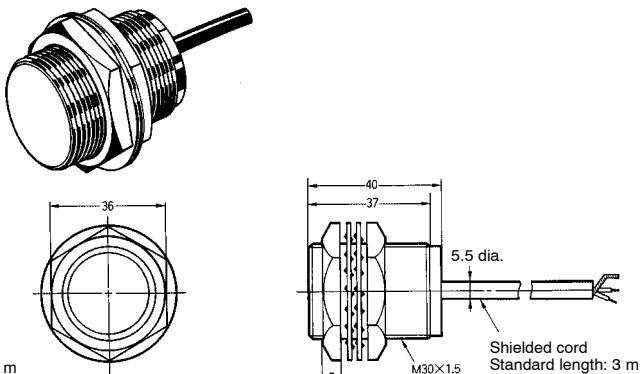

Amplifier Units

E2CA-A□C/F
E2CA-A□D/E

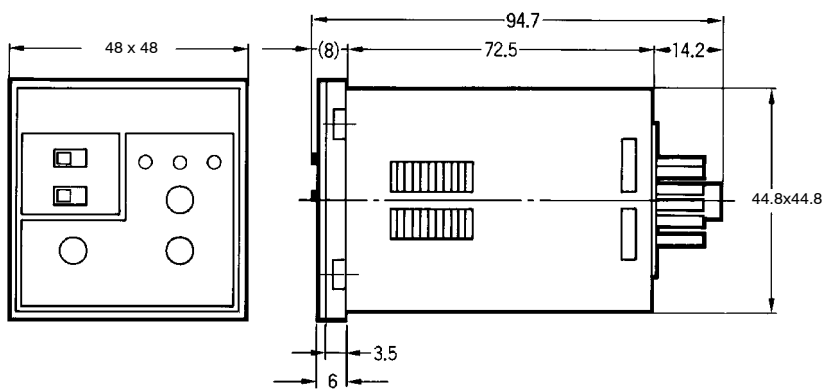

Mounting Hole Dimensions

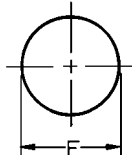

Model	F (mm)
E2CA-X1R5A	8.5 ^{+0.5} ₀ dia.
E2CA-X2A	12.5 ^{+0.5} ₀ dia.
E2CA-X5A	18.5 ^{+0.5} ₀ dia.
E2CA-X10A	30.5 ^{+0.5} ₀ dia.

Accessories (Order Separately)

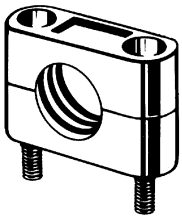

Mounting Fixture (Y92E-B Series)

Four types of exclusive resin mounting fixtures are optionally available. Select the type suited to the dimensions of the Sensor.

Y92F-30 Adapter for Flush Mounting

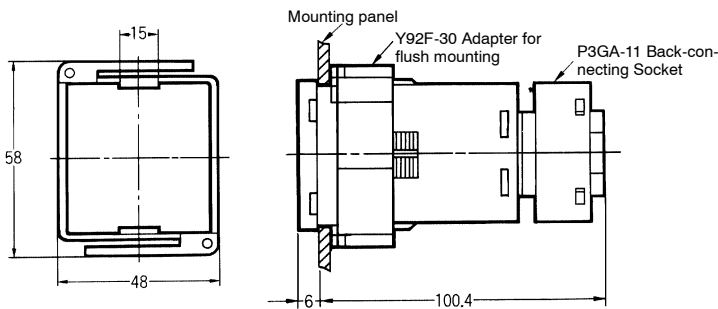

Y92A-48B Protective Cover

The protective hard plastic cover shields the front panel, particularly the setting section, from dust, dirt, and water drip.

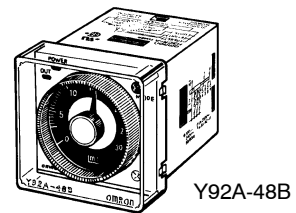

Connecting Sockets for E2CA-A□4□

P2CF-11 Front-connecting Socket (Track Mounted)

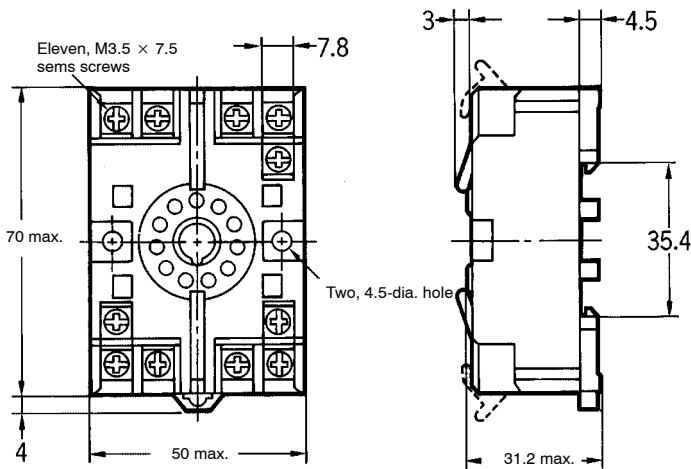

Terminal Arrangement (Top View)

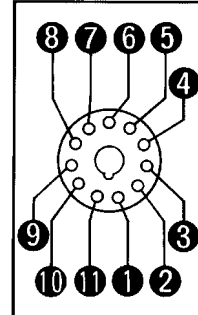

Mounting Holes

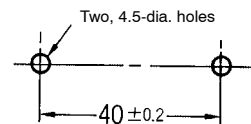

Note: The Socket can be mounted to a track.

P3GA-11 Back-connecting Socket

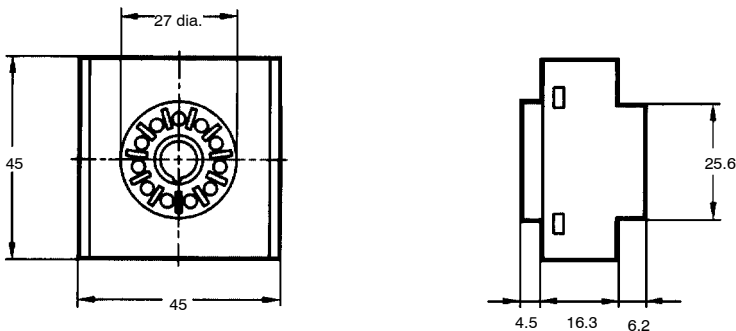

Terminal Arrangement (Bottom View)

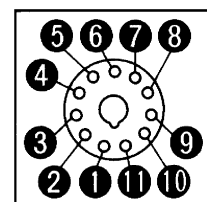

PL11 Back-connecting Socket (Solder Terminal)

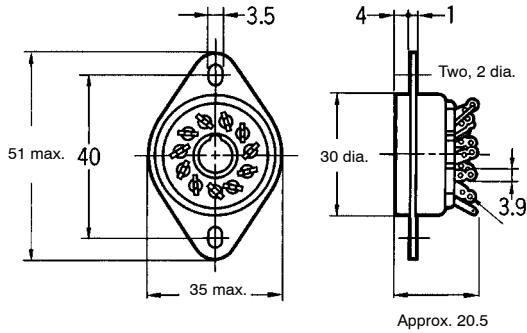

Terminal Arrangement (Bottom View)

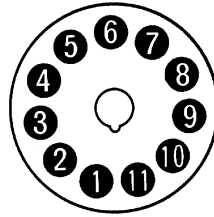

Mounting Holes

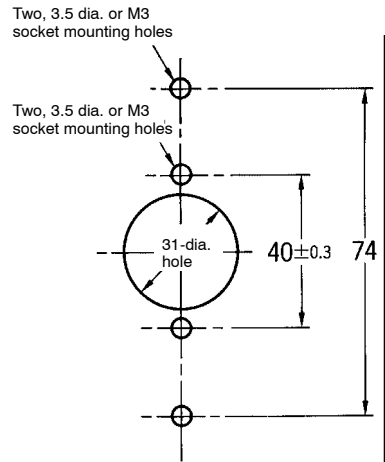

Precautions

Correct Use

Mounting

Do not tighten the nut of the Sensor with excessive force. Be sure to use the washer with the nut when tightening.

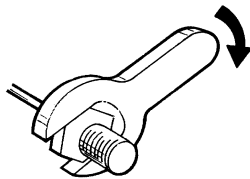

Model	Tightening torque
E2CA-X1R5A	1.96 N • m (20 kgf • cm)
E2CA-X2A	5.9 N • m (60 kgf • cm)
E2CA-X5A	14.7 N • m (150 kgf • cm)
E2CA-X10A	39.2 N • m (400 kgf • cm)

Note: The above tightening torque applies when a toothed washer is used.

Effects of Surrounding Metal

Be sure to separate the Sensor from surrounding metal objects as shown in the following illustration if the Sensor is embedded.

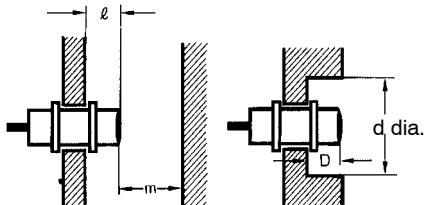

Model/Distance	l	d	D	m
E2CA-X1R5A	0	(8)	0	4.5
E2CA-X2A	0	(12)	0	6
E2CA-X5A	0	(18)	0	15
E2CA-X10A	0	(30)	0	30

Note: The values for "d" indicate distances for the outer diameter of the shielded models.

Mutual Interference

If the Sensors are mounted in parallel or face-to-face, be sure to keep the clearance between the Sensors as specified in the table.

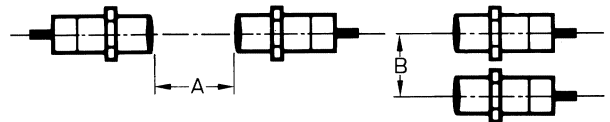

Model/Distance	A	B
E2CA-X1R5A	30	20
E2CA-X2A	30	20
E2CA-X5A	50	35
E2CA-X10A	100	75

Sensor Cord

The Sensor cord must be either 3 or 5 m. Do not cut or extend the Sensor cord, otherwise the E2CA may not provide the specified output.

Mounting the Amplifier Unit

When mounting more than one amplifier vertically, it is recommended that a margin of approximately 20 mm above and below the Socket be provided in consideration of the space required by the hook of the Socket.

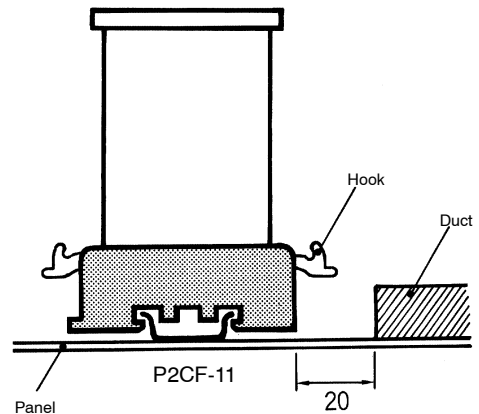

Enclosed Mounting

If the Y92F-30 Adapter is used, insert the E2CA into the square hole from the front side of the panel and slide the Y92F-30 onto the E2CA from the rear side of the E2CA. Then press the Y92F-30 so that the space between the Y92F-30 and the panel is reduced as much as possible. Finally, secure the Y92F-30 with screws.

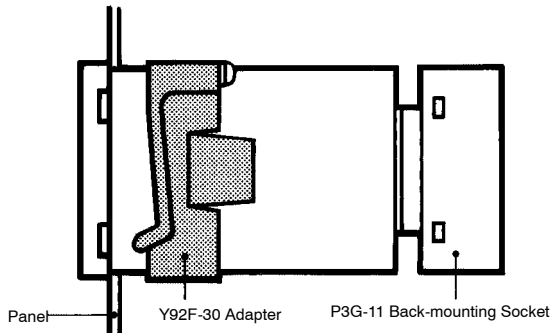
**Removing the Amplifier Unit**

If the Y92F-30 is used, loosen the screws of the Y92F-30, spread out the hooks, and remove the Y92F-30.

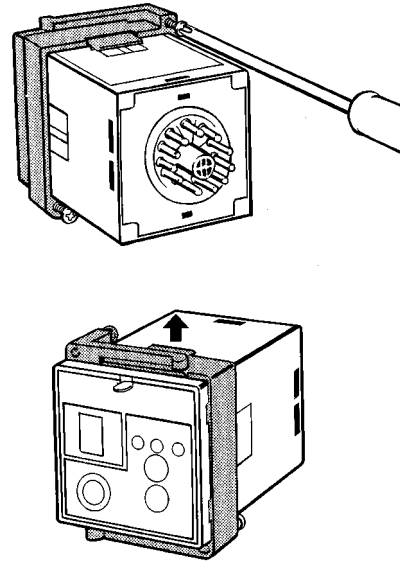
**Others**

The accuracy of the E2CA will vary with the on-site environment. The resolution, temperature characteristics, and voltage characteristic linearity are especially affected. Therefore, keep the on-site environment as suitable for the E2CA as possible.

ALL DIMENSIONS SHOWN ARE IN MILLIMETERS.

To convert millimeters into inches, multiply by 0.03937. To convert grams into ounces, multiply by 0.03527.

OMRON Corporation

Industrial Sensors Division
Sensing Devices and Components Division H.Q.
28th Fl., Crystal Tower Bldg.
1-2-27, Shiromi, Chuo-ku,
Osaka 540-6028 Japan
Phone: (81)6-949-6012 Fax: (81)6-949-6021