

Spatter immune Proximity Sensors

E2EQ

A Series of Spatter-resistant Proximity Sensors with a Teflon-coated Metal Housing

- Long sensing-distance type included in series.



* Teflon is a registered trademark of Dupont Company and Mitsui Dupont Chemical Company for their fluoride resin.

Ordering Information

Sensors

- Pre-wired Models

Long-distance type

Shape		Sensing distance			Output specifications	Operating status	Model
Shielded 	M12	4mm			DC 2-wire	NO	E2EQ-X4X1
	M18	8mm					E2EQ-X8X1
	M30	15mm					E2EQ-X15X1

Standard

Shape		Sensing distance			Output specifications	Operating status	Model
Shielded 	M12	3mm			DC 2-wire	NO	E2EQ-X3D1
	M18	7mm					E2EQ-X7D1
	M30	10mm					E2EQ-X10D1

- Plug-in Models

Long-distance type

Shape		Sensing distance			Output specifications	Operating status	Model
Shielded 	M12	4mm			DC 2-wire models (3) and (4) Pin arrangement	NO	E2EQ-X4X1-M1J
	M18	8mm					E2EQ-X8X1-M1J
	M30	15mm					E2EQ-X15X1-M1J





Standard

Standard		Sensing distance			Output specifications	Operating status	Model
Shielded 	M12	3mm			DC 2-wire models (1) and (4) Pin arrangement	NO	E2EQ-X3D1-M1GJ
	M18	7mm					E2EQ-X7D1-M1GJ
	M30	10mm					E2EQ-X10D1-M1GJ

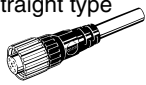

Accessories (Order Separately)

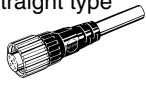
Sensor I/O Connectors

Shape	Cable length	Sensor I/O Connectors	Applicable proximity sensor models
 Straight type	2 m	XS2F-D421-DCO-A	E2EQ-X□X1-M1J
	5 m	XS2F-D421-GCO-A	
 L type	2 m	XS2F-D422-DCO-A	
	5 m	XS2F-D422-GCO-A	
 Straight type	2 m	XS2F-D421-DA0-A	E2EQ-X□D1-M1GJ
	5 m	XS2F-D421-GA0-A	
 L type	2 m	XS2F-D422-DA0-A	
	5 m	XS2F-D422-GA0-A	

Rating/Performance

Long-distance type

Item	Model	E2EQ-X4X1 E2EQ-X4X1-M1J	E2EQ-X8X1 E2EQ-X8X1-M1J	E2EQ-X15X1 E2EQ-X15X1-M1J
Sensing distance		4 mm ±10%	8 mm ±10%	15 mm ±10%
Setting distance*1		0 to 3.2 mm	0 to 6.4 mm	0 to 12 mm
Differential distance		15% max. of sensing distance		
Standard sensing object (mild steel)		12 x 12 x 1 mm	18 ± 18 ± 1 mm	30 ± 30 ± 1 mm
Response frequency*2		1 kHz	0.5 kHz	0.25 kHz
Control output	Switching capacity	3 to 100 mA		
	Residual voltage*3	5.0 V max. (under load current of 100 mA with cable length of 2 m)		
Operating status (with sensing object approaching)		C1 models: NO		
Protective circuits		Surge absorber, load short-circuit protection		
Ambient temperature		Operating: -25°C to 70°C, Storage: -40°C to 85°C (with no icing or condensation)		
Temperature influence		±15% max. of sensing distance at 23°C within temperature range of -40°C to 85°C ±10% max. of sensing distance at 23°C within temperature range of -25°C to 70°C		±15% max. of sensing distance at 23°C within temperature range of -25°C to 70°C
Voltage influence		±1% max. of Sensing distance in rated voltage range ±15%.		
Shock resistance		Destruction: 1,000 m/s ² for 10 times each in X, Y, and Z directions		
Connection method		Pre-wired (standard length: 2 m) Connector Extension Models		
Weight (Packed state)	Pre-wired	65 g	Approx. 140 g	Approx. 190 g
	Junction connector	Approx. 20 g	Approx. 40g	Approx. 90 g

*1. Use within a range where the green indicator is lit.

*2. The response frequencies for DC switching are average values.

*3. Since residual voltage is 5 V, use it after checking interface requirements with the connection devices.

Standard

Model		E2EQ-X3D1 E2EQ-X3D1-M1GJ	E2EQ-X7D1 E2EQ-X7D1-M1GJ	E2EQ-X10D1 E2EQ-X10D1-M1GJ
Item				
Sensing distance		3 mm \pm 10%	7 mm \pm 10%	10 mm \pm 10%
Setting distance		0 to 2.4 mm	0 to 5.6 mm	0 to 8 mm
Differential distance		10% max.		
Standard sensing object (mild steel)		12 x 12 x 1 mm	18 x 18 x 1 mm	30 x 30 x 1 mm
Response frequency		1 kHz	500 Hz	400 Hz
Control output	Switching capacity	3 to 100 mA		
	Residual voltage	3.0 V max. (under load current of 100 mA with cable length of 2 m)		
Operating status (with sensing object approaching)		NO		
Protective circuits		Surge absorber, short-circuit protection		
Ambient temperature		Operating/Storage: -25°C to 70°C (with no icing or condensation)		
Temperature influence		\pm 10% max. of sensing distance at 23°C within temperature range of -25°C and 70°C		
Voltage influence		\pm 2.5% max. of Sensing distance within rated voltage range \pm 15%.		
Shock resistance		Destruction: 1,000 m/s ² for 10 times each in X, Y, and Z directions		
Connection method		E2EQ-X□D1: Pre-wired models (Standard length: 2 m) E2EQ-X□D1-M1GJ type: Connector relay models (Standard length: 300 mm)		
Weight (Packed state)	Pre-wired	Approx. 120 g	Approx. 160 g	Approx. 220 g
	Junction connector	Approx. 80 g	Approx. 110 g	Approx. 190 g

* The response frequencies for DC switching are average values measured on condition that the distance between each sensing object is twice as large as the size of the sensing object and the sensing distance set is half of the maximum sensing distance.

General

Model		E2EQ-X4X1 E2EQ-X4X1-M1J E2EQ-X3D1 E2EQ-X3D1-M1GJ	E2EQ-X8X1 E2EQ-X8X1-M1J E2EQ-X7D1 E2EQ-X7D1-M1GJ	E2EQ-X15X1 E2EQ-X15X1-M1J E2EQ-X10D1 E2EQ-X10D1-M1GJ
Item				
Sensing object		Ferrous metal (Sensitivity lowers with non-ferrous metals)		
Rated supply voltage (operating voltage)		12 to 24 VDC (10 to 30 VDC), ripple (p-p): 10% max.		
Leakage current		0.8 mA max.		
Indicator lamp		Operation indicator (red), operation setting indicator (green)		
Ambient humidity		Operating/Storage: 35% to 95%RH (with no condensation)		
Insulation resistance		50 M Ω min. (at 500 VDC) between energized parts and case		
Dielectric strength		1,000 VAC for 1 min between energized parts and case		
Vibration resistance		10 to 55 Hz, 1.5 mm double amplitude for 2 hours each in X, Y, and Z directions		
Protective structure		IEC60529 IP67		
Material	Case	Teflon resin coating (base: brass) *		
	Sensing surface	Teflon resin *		
Accessories		Instruction manual		

* Teflon is a registered trademark of Dupont Company and Mitsui Dupont Chemical Company for their fluoride resin.

Characteristic data (typical)

Sensing Distance vs. Sensing Object

E2EQ-X4X1(-M1J)

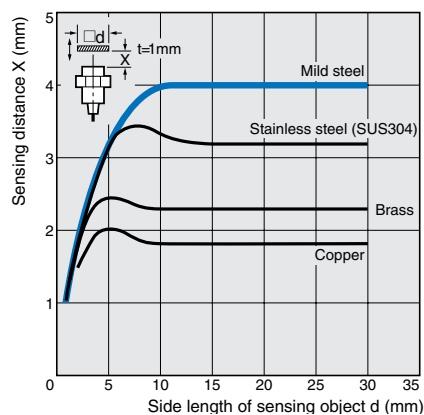

E2EQ-X8X1(-M1J)

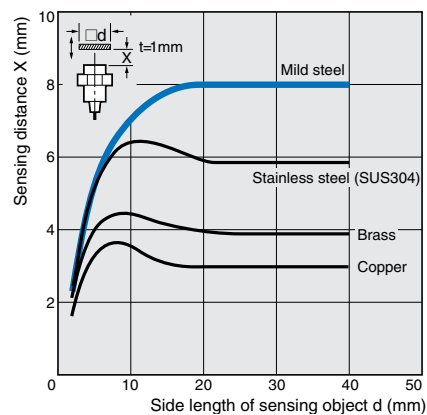

E2EQ-X15X1(-M1J)

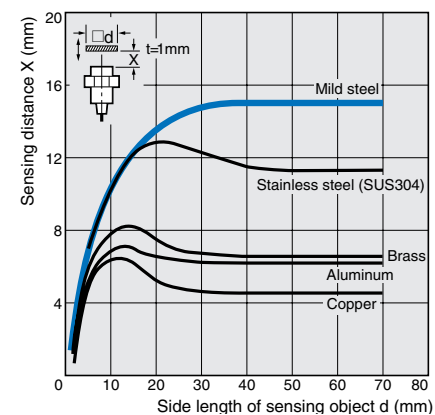

E2EQ-X3D1(-M1GJ)

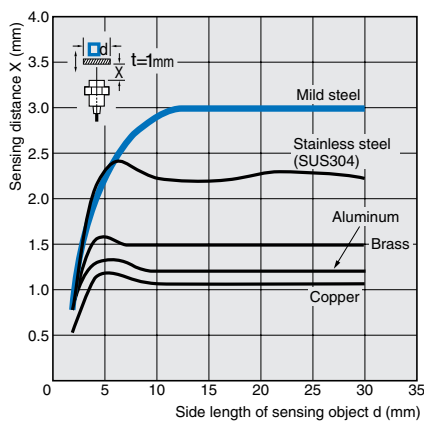

E2EQ-X7D1(-M1GJ)

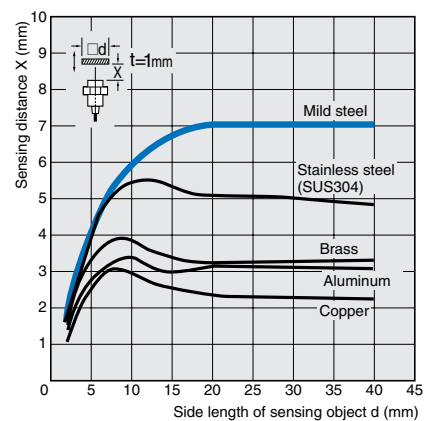

E2EQ-X10D1(-M1GJ)

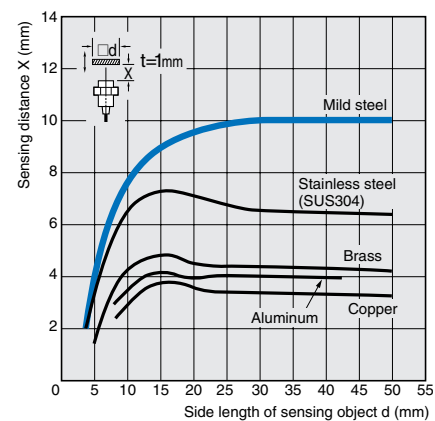

Output Circuit Diagram

Long-distance type

Model	Operating status	Timing chart	Output circuit
E2EQ-X4X1 E2EQ-X8X1 E2EQ-X15X1 E2EQ-X4X1-M1J E2EQ-X8X1-M1J E2EQ-X15X1-M1J	NO		<p>Note: 1. The load can be connected to either the +V or the 0-V line. 2. Since there is no polarity, there is no need to pay attention to the brown or blue polarity.</p> <p>Wiring</p> <p>Note: Terminals ② and ③ are not used.</p>

Standard

Model	Operating status	Timing chart	Output circuit
E2EQ-X3D1 E2EQ-X7D1 E2EQ-X10D1 E2EQ-X3D1-M1GJ E2EQ-X7D1-M1GJ E2EQ-X10D1-M1GJ	NO		<p>Note: The Load can be connected to either the +V or the 0-V line.</p> <p>Wiring</p> <p>Note: Terminals ② and ③ are not used.</p>

Connecting Plug-in models

Model	E2EQ-X□X1-M1J	E2EQ-X□D1-M1GJ
Connection	Connector relay type E2EQ-X□X1-M1J 	Connector relay type E2EQ-X□D1-M1GJ
	Sensor I/O Connectors XS2F-D42□-□C0-A 	Sensor I/O Connectors XS2F-D42□-□A0-A

Precautions

Correct Use

Design

Effects of Surrounding Metal

Provide a minimum distance between the Sensor and the surrounding metal as shown in the table below.

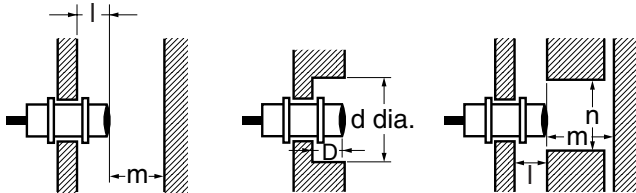

Effects of Surrounding Metal (Unit: mm)

Model	Item	l	d	D	m	n
E2EQ-X4X1(-M1J)		2.4	18	2.4	12	18
E2EQ-X8X1(-M1J)		3.6	27	3.6	24	27
E2EQ-X15X1(-M1J)		6	45	6	45	45
E2EQ-X3D11(-M1GJ)			12		8	18
E2EQ-X7D1(-M1GJ)		0	18	0	20	27
E2EQ-X10D1(-M1GJ)			30		40	45

Mutual Interference

If more than one Proximity Sensor is installed face to face or in parallel, make sure that the distances between two Units adjacent to each other are the same as or larger than the corresponding values shown in the following table.

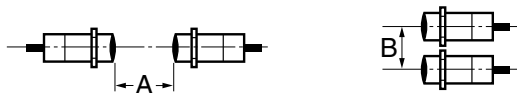

Mutual Interference(Unit: mm)

Model	Item	A	B
E2EQ-X4X1(-M1J)		30	20
E2EQ-X8X1(-M1J)		60	35
E2EQ-X15X1(-M1J)		110	90
E2EQ-X3D1(-M1GJ)		30	20
E2EQ-X7D1(-M1GJ)		50	35
E2EQ-X10D1(-M1GJ)		100	70

Mounting

Do not tighten the nut with excessive force. A washer must be used with the nut.

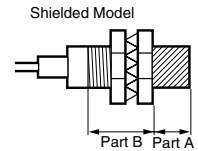
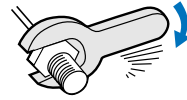

Note: 1 . The table below shows the tightening torques for part A and part B nuts. In the previous examples, the nut is on the sensor head side (part B) and hence the tightening torque for part B applies. If this nut is in part A, the tightening torque for part A applies instead.

2 . The table below shows the value of tightening torques when using toothed washers.

Model	Torque Length (mm)	Part A	Part B
		Torque	Torque
E2EQ-X4X1(-M1J)	---	30 Nm	
E2EQ-X8X1(-M1J)		70 Nm	
E2EQ-X15A(-M1J)		180 Nm	
E2EQ-X3D1(-M1GJ)	24	15 Nm	---
E2EQ-X7D1(-M1GJ)	29		
E2EQ-X10D1(-M1GJ)	26	39 Nm	78 Nm

Dimensions (Unit: mm)

● Pre-wired Models

Long-distance type

E2EQ-X4X1 CAD file **E2EQ_03**

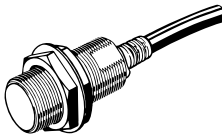
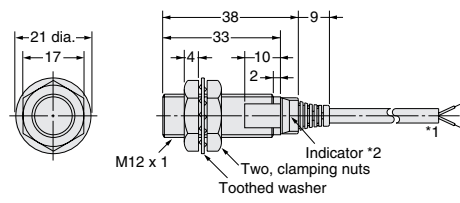
*1: Vinyl-insulated round cable (flame-resistant), 4 dia.
2/3 conductors (conducting cross-sectional area: 0.3 mm²/insulator diameter: 1.3 mm
Standard length: 2m
Cable extension (through a single metal conduit): 200m max.
*2: Operation indicator (red) and setting indicator (green).

E2EQ-X8X1 CAD file **E2EQ_01**

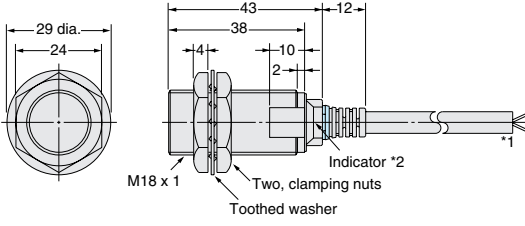

*1: Vinyl-insulated round cable (flame-resistant), 6 dia.
2/3 conductors (conducting cross-sectional area: 0.5 mm²/insulator diameter: 1.9 mm
Standard length: 2m
Cable extension (through a single metal conduit): 200m max.
*2: Operation indicator (red) and setting indicator (green).

E2EQ-X15X1 CAD file **E2EQ_05**

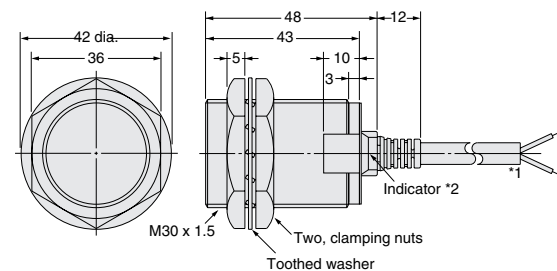

*1: Vinyl-insulated round cable (flame-resistant), 6 dia.
2/3 conductors (conducting cross-sectional area: 0.5 mm²/insulator diameter: 1.9 mm
Standard length: 2m
Cable extension (through a single metal conduit): 200m max.
*2: Operation indicator (red) and setting indicator (green).

Standard

E2EQ-X3D1 CAD file **E2EQ_03**

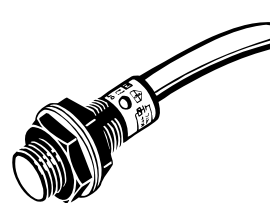
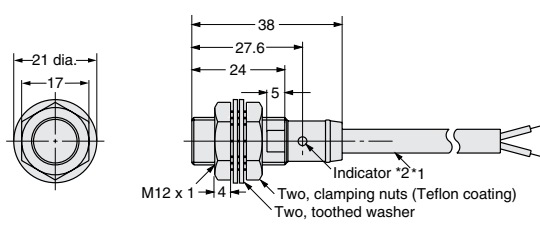
*1: Vinyl-insulated round cable (flame-resistant), 6 dia., 2 conductors (conducting cross-sectional area: 0.5 mm²/insulator diameter: 1.9 mm
Standard length: 2m
Cable extension (through a single metal conduit): 200m max.
*2: Operation indicator (red) and setting indicator (green).

E2EQ-X7D1 CAD file **E2EQ_05**

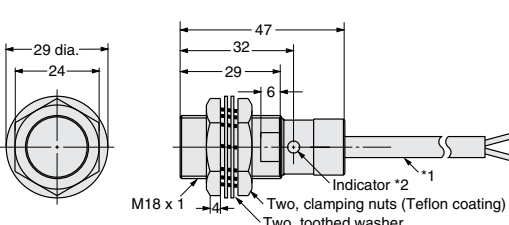

*1: Vinyl-insulated round cable (flame-resistant), 6 dia., 2 conductors (conducting cross-sectional area: 0.5 mm²/insulator diameter: 1.9 mm
Standard length: 2m
Cable extension (through a single metal conduit): 200m max.
*2: Operation indicator (red) and setting indicator (green).

E2EQ-X10D1 CAD file **E2EQ_01**

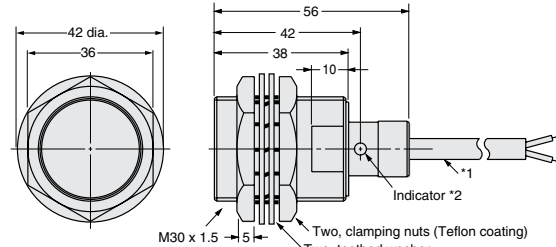

*1: Vinyl-insulated round cable (flame-resistant), 6 dia., 2 conductors (conducting cross-sectional area: 0.5 mm²/insulator diameter: 1.9 mm
Standard length: 2m
Cable extension (through a single metal conduit): 200m max.
*2: Operation indicator (red) and setting indicator (green).

● Plug-in Models
Long-distance type

E2EQ-X4X1-M1J

CAD file E2EQ_07

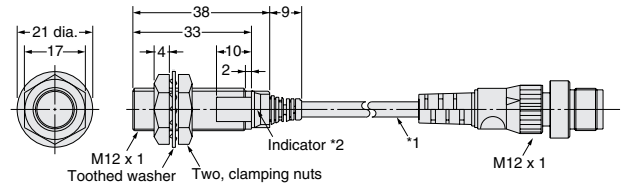
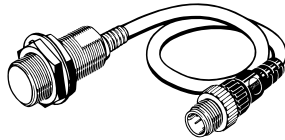

*1: Vinyl-insulated round cable (flame-resistant), 4 dia. (Conducting cross-sectional area: 0.3 mm²; insulator diameter: 1.3 mm)
Standard length: 300 mm
*2: Operation indicator (red) and setting indicator (green).

E2EQ-X8X1-M1J

CAD file E2EQ_08

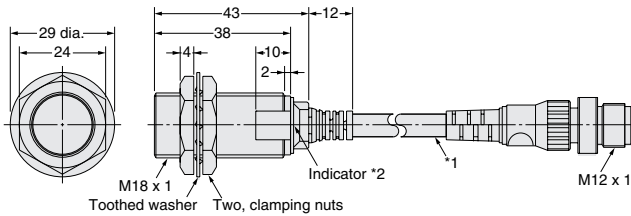

*1: Vinyl-insulated round cable (flame-resistant), 5 dia. (Conducting cross-sectional area: 0.5 mm²; insulator diameter: 1.9 mm)
Standard length: 300 mm
*2: Operation indicator (red) and setting indicator (green).

E2EQ-X15X1-M1J

CAD file E2EQ_09

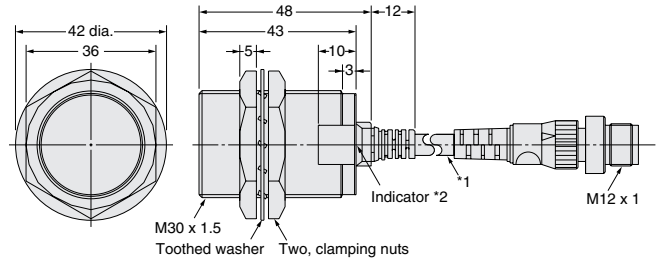

*1: Vinyl-insulated round cable (flame-resistant), 5 dia. (Conducting cross-sectional area: 0.5 mm²; insulator diameter: 1.9 mm)
Standard length: 300 mm
*2: Operation indicator (red) and setting indicator (green).

Standard

E2EQ-X3D1-M1GJ

CAD file E2EQ_04

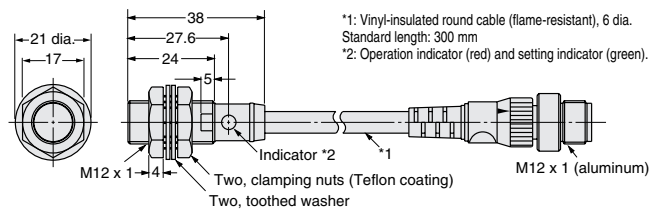
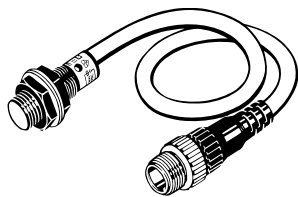

*1: Vinyl-insulated round cable (flame-resistant), 6 dia. Standard length: 300 mm
*2: Operation indicator (red) and setting indicator (green).

E2EQ-X7D1-M1GJ

CAD file E2EQ_06

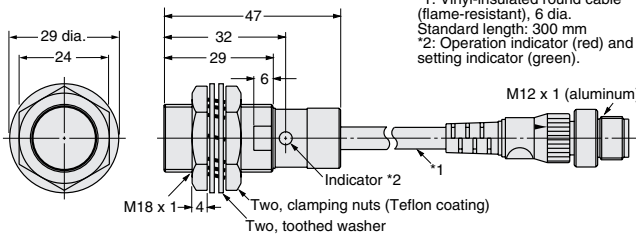

*1: Vinyl-insulated round cable (flame-resistant), 6 dia. Standard length: 300 mm
*2: Operation indicator (red) and setting indicator (green).

E2EQ-X10D1-M1GJ

CAD file E2EQ_02

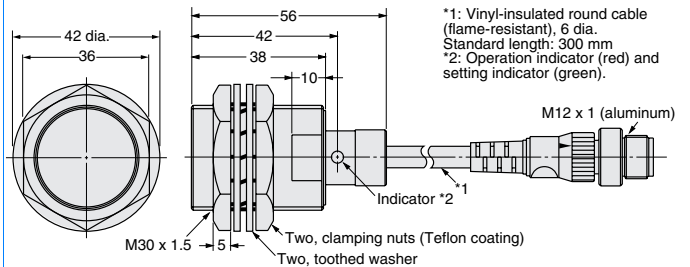

*1: Vinyl-insulated round cable (flame-resistant), 6 dia. Standard length: 300 mm
*2: Operation indicator (red) and setting indicator (green).

Mounting Holes

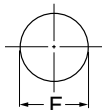

Outer diameter	M12	M18	M30
F (mm)	12.5 dia. ^{+0.5}	18.5 dia. ^{+0.5}	30.5 dia. ^{+0.5}