

查询HPS3KW供应商

捷多邦, 专业PCB打样工厂, 24小时加急出货

3000 Watts HPS3KW



Total Power: **3000 Watts**
Input Voltage: **180-264 VAC**
of Outputs: **Single**

Electrical Specs - * Module only

Input

Input Range 180-264VAC
Frequency 47 - 63 Hz
Inrush Current 100A (peak)
Efficiency 85% typical at full load
EMI Filter CISPR22 Class A
Power Factor 0.98 typical
Leakage Current 1.16 mA @ 240 VAC

Output

DC Voltage 51.4V @ 57A*
5Vsb @ 5A
Adjustment Range ± 5%
Supervisory Output 5V @ 5A
Hold Up Time 20ms
Over Current 51.4V: 110% - 150%
5Vsb: 101% - 125%

Over Voltage

60V Max

Logic Control

ENABLE

Requires contact closure from "PSON" to 5Vsb return.

AC OK

TTL signal LOW

POWER FAIL

TTL signal LOW; goes HIGH in the event of failure

POWER GOOD

TTL logic signal goes high 100-1000 msec after 48VDC output. It goes LOW at least 1ms before loss of regulation.

* 10% Minimum load required.

Special Features - * Module only

- Active Power Factor Correction
- EN61000-3-2 Harmonic Compliance
- Remote INHIBIT
- Single Wire Parallel
- Built-in EMI Filter
- Low Output Ripple
- +5V standby Output
- Built-in Cooling Fans
- Over Current Protection
- Over Voltage Protection
- Over Temperature Protection
- Hot Swap
- Built-in OR'ing Diodes

Environmental - * Module only

Operating Temperature: +5°C to 40°C

Non-Operating Temperature: -40° to +70°C

Electromagnetic Susceptibility: Designed to meet EN61000-4-2, -4-3, 4-4, -4-5 Level 3

Humidity: 5 to 95% RH, non-condensing

Operating: Sinusoidal Vibration - 0.25G zero to peak, 10 to 500Hz, 0.25 oct/min in each three mutually perpendicular axes. Random vibration - 0.002 G²/Hz, 10 to 500Hz, nominal 1G rms.

Non-operating: Sinusoidal Vibration - 0.75G zero to peak, 10 to 500Hz, 0.50 oct/min in each three mutually perpendicular axes. Random vibration - 0.008 G²/Hz, 10 to 500Hz, nominal 2G rms.

MTBF (demonstrated): >500Khrs at full load, 40°C

Safety - * Module only

UL 60950 (UL Recognized)
NEMKO EN60950
TUV EN60950
CE Mark



HPS3KW Module

AMERICAS

5810 Van Allen Way
 Carlsbad, CA 92008
 Telephone: 760-930-4600
 Facsimile: 760-930-0698

EUROPE

Astec House, Waterfront Business Park
 Merry Hill, Dudley
 West Midlands, DY5 1LX, UK
 Telephone: 44 (1384) 842-211
 Facsimile: 44 (1384) 843-355

ASIA

Units 2111-2116, Level 21
 Tower 1, Metroplaza
 223, Hing Fong Road
 Kwai Fong, New Territories
 Hong Kong
 Telephone: 852-2437-9662
 Facsimile: 852-2402-4426



Ordering Information

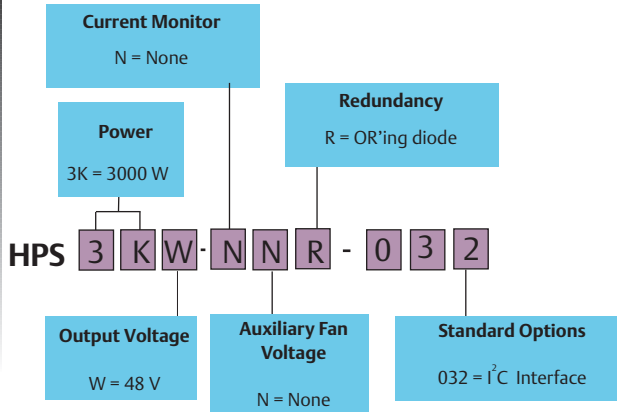

DC Output Connector Pinout Assignment

	Signal Pins				
	1	2	3	4	5
D	5Vsb	5Vsb rtn	PSON	SCL	A0
C	5Vsb	5Vsb rtn	PRESENT	SCL/SDA RTN	A1
B	5Vsb	5Vsb rtn	PSKI LL	SDA	A2
A	48LS	AC OK	PWOK	FAIL	Reserved

Power Blades

P1, P2
48VDC RETURN

P3, P4
48VDC

DC OUTPUT CONNECTOR: FCI 51874-001
 DC OUTPUT MATING CONNECTOR: FCI 51875-001

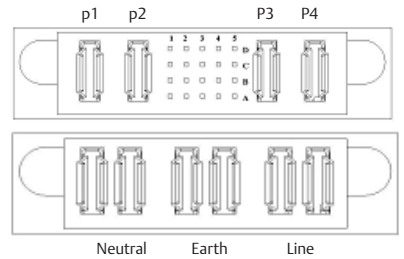

Mechanical Drawings

AC INPUT CONNECTOR: FCI 51870-001
 AC MATING CONNECTOR: FCI 51871-001
 (REQUIRES 2 FCI 51869-001 BACKSHELL)

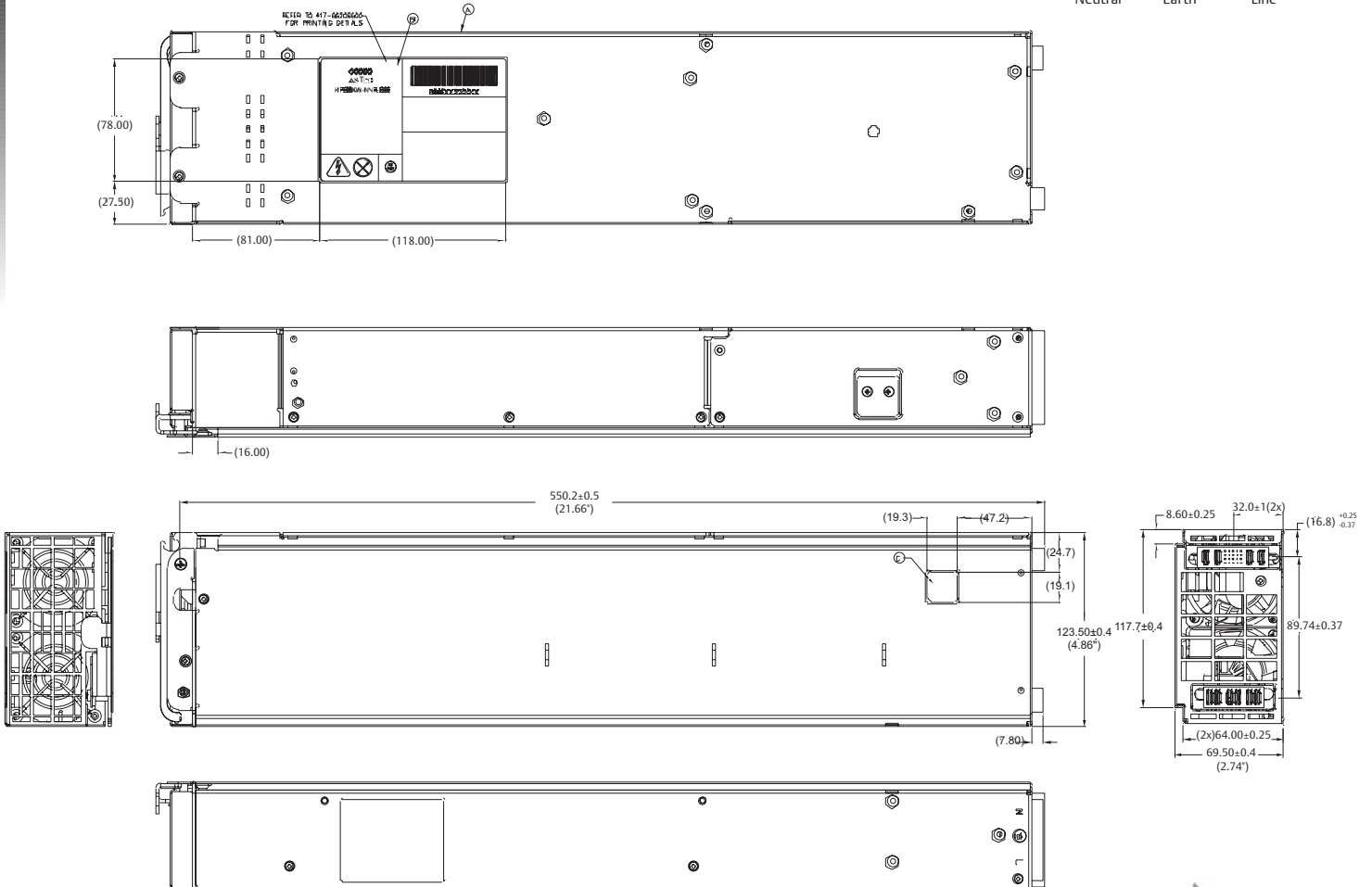

HPS3KW Rack

Ordering Information

- Hot Swap
- Can accommodate up to 18KW of bulk power
- Easy AC input connect
- Easy DC output connect

