

16 Channel High Voltage Analog Switch With Bleed Resistors

Features

- ❑ HVCMOS technology for high performance
- ❑ 220V operating conditions
- ❑ Output On-resistance typically 22Ω
- ❑ Integrated bleed resistors on the outputs
- ❑ 5.0V and 12.0V CMOS logic compatibility
- ❑ Very low quiescent power dissipation -10μA
- ❑ -45dB min off isolation at 7.5MHz
- ❑ Low parasitic capacitance
- ❑ Excellent noise immunity
- ❑ Flexible operating supply voltages

Applications

- ❑ Medical ultrasound imaging
- ❑ Non-destructive evaluation

Description

The Supertex HV238 is a 220V 16-channel high voltage analog switch integrated circuit (IC) with output bleed resistors (R_{INT}). The output switches are configured as 2 sets of 8 single pole single throw analog switches. It is intended to be used in applications requiring high voltage switching controlled by low voltage control signals such as ultrasound imaging.

The 2 sets of 8 analog switches are controlled by 2 input logic controls, D_{IN1} and D_{IN2} . A logic high on D_{IN1} will turn ON switches 0 to 7 and a logic high on D_{IN2} will turn ON switches 8 to 15. The bleed resistors help to significantly reduce voltage built up on capacitive loads such as piezoelectric transducers connected to the outputs.

Block Diagram

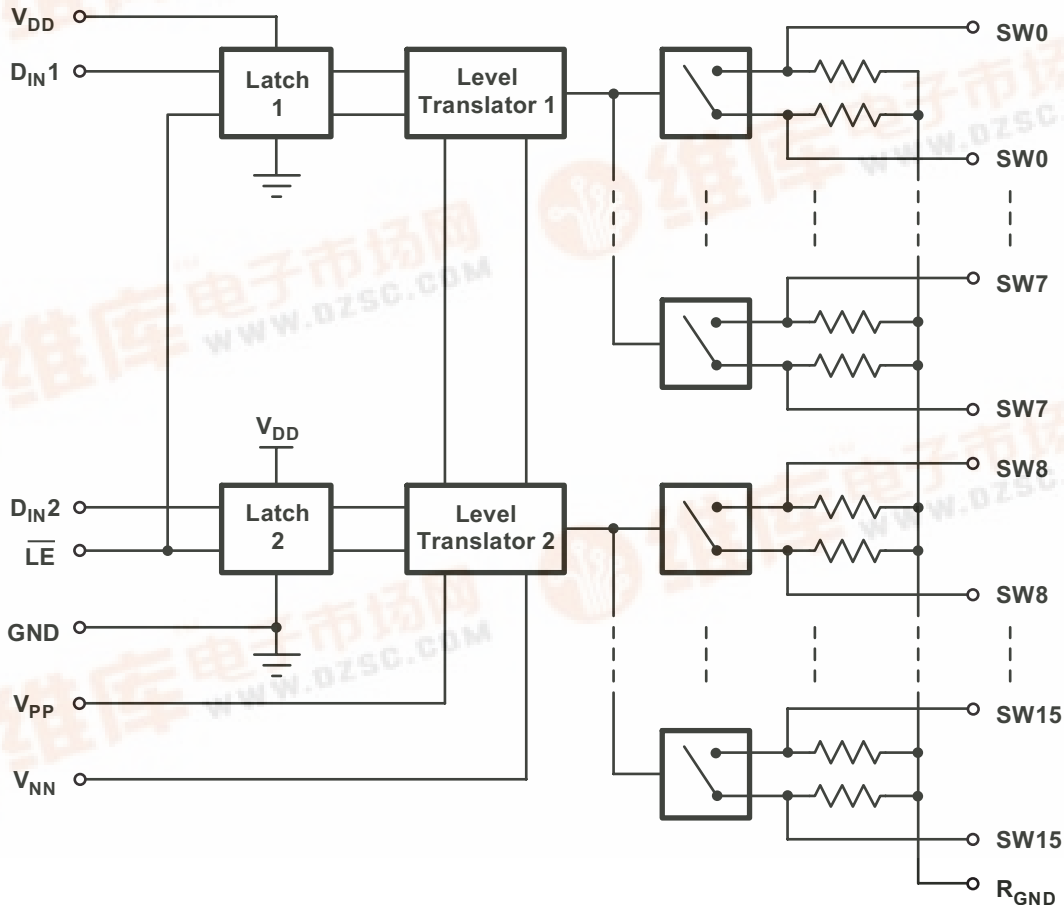

Ordering Information

Device	Package Options
	48-lead TQFP
HV238	HV238FG

Absolute Maximum Ratings*

V _{DD} Logic supply	-0.5V to +15V	
V _{PP} -V _{NN} differential supply	225V	
V _{PP} Positive supply	-0.5V to V _{NN} +225V	
V _{NN} Negative supply	+0.5V to -225V	
Logic input voltage	-0.5V to V _{DD} +0.3V	
Analog signal range	V _{NN} to V _{PP}	
Peak analog signal current/channel	3.0A	
Storage temperature	-65°C to 150°C	
Power dissipation	48-lead TQFP	1.0W

*Absolute Maximum Ratings are those values beyond which damage to the device may occur. Functional operation under these conditions is not implied. Continuous operation of the device at the absolute rating level may affect device reliability.

Operating Conditions*

Symbol	Parameter	Value
V _{PP}	Positive high voltage supply	50V to 110V
V _{NN}	Negative high voltage supply	-10V to V _{PP} -220V
V _{DD}	Logic power supply voltage	4.75V to 12.6V
V _{IH}	High level input voltage	V _{DD} -1.0V to V _{DD}
V _{IL}	Low level input voltage	0V to 1.0V
V _{SIG}	Analog signal voltage peak-to-peak	V _{NN} +10V to V _{PP} -10V
T _A	Operating free air temperature	0°C to 70°C

*** Notes:**

- 1 Power up/down sequence is arbitrary except GND must be powered-up first and powered-down last.
- 2 V_{SIG} must be within V_{NN} and V_{PP} or floating during power up/down transition.
- 3 Rise and fall times of power supplies V_{DD}, V_{PP}, and V_{NN} should not be less than 1.0msec.

Truth Table

D _{IN2}	D _{IN1}	\overline{LE}	SW0 to SW7	SW8 to SW15
L	L	L	OFF	OFF
L	H	L	ON	OFF
H	L	L	OFF	ON
H	H	L	ON	ON
X	X	H	Hold Previous State	

Electrical Characteristics

DC Characteristics (over recommended operating conditions unless otherwise noted)

Sym	Parameter	0°C		+25°C			+70°C		Units	Conditions
		Min	Max	Min	Typ	Max	Min	Max		
R _{ONS}	Small Signal Switch On-Resistance		30		26	32		40	Ω	V _{SIG} = 0V, I _{SIG} = 5mA, V _{PP} = 50V, V _{NN} = -170V
			25		22	27		35		V _{SIG} = 0V, I _{SIG} = 200mA, V _{PP} = 50V, V _{NN} = -170V
			15		22	27		30		V _{SIG} = 0V, I _{SIG} = 5mA, V _{PP} = 110V, V _{NN} = -110V
			20		18	22		25		V _{SIG} = 0V, I _{SIG} = 200mA, V _{PP} = 110V, V _{NN} = -110V
ΔR _{ONS}	Small Signal Switch On-Resistance Matching		20		5.0	20		20	%	V _{SIG} = 0V, I _{SIG} = 5mA, V _{PP} = 110V, V _{NN} = -110V
R _{ONL}	Large Signal Switch On-Resistance				15				Ω	V _{SIG} = 0V, I _{SIG} = 1.0A
R _{INT}	Output Switch Shunt Resistance			20	35	50			KΩ	Output Switch to R _{GND} I _{RINT} = 0.5mA
I _{SOL}	Switch Off Leakage per Switch		5.0		1.0	10		15	μA	V _{SIG} = V _{PP} -10V and V _{NN} = +10V
	DC offset Switch off		300		100	300		300	mV	No Load
	DC offset Switch on		500		100	500		500	mV	No Load
I _{PPQ}	Quiescent V _{PP} supply current				10	50			μA	All switches off
I _{NNQ}	Quiescent V _{NN} supply current				-10	-50			μA	All switches off
I _{PPQ}	Quiescent V _{PP} supply current				10	50			μA	All switches on, I _{SW} = 5mA
I _{NNQ}	Quiescent V _{NN} supply current				-10	-50			μA	All switches on, I _{SW} = 5mA
	Switch output peak current		3.0		3.0	2.0		2.0	A	V _{SIG} duty cycle < 0.1%
f _{SW}	Output switch frequency					50			kHz	Duty cycle=50%
I _{PP}	Average V _{PP} supply current		6.5			8.8		10	mA	V _{PP} = 50V, V _{NN} = -170V, All Switches turning ON and OFF at 50kHz
I _{NN}	Average V _{NN} supply current		8.1			-8.8		-10		
I _{PP}	Average V _{PP} supply current		-8.1			6.3		6.9	mA	V _{PP} = 110V, V _{NN} = -110V, All Switches turning ON and OFF at 50kHz
I _{NN}	Average V _{NN} supply current		5.0			-6.3		-6.9		
I _{DDQ}	Quiescent V _{DD} supply current		10			10		10	μA	All logic inputs are static
I _{DD}	Average V _{DD} supply current		2.0			2.0		2.0	mA	D _{IN1} = D _{IN2} = 3MHz, LE = high
C _{IN}	Logic input capacitance		10			10		10	pF	

Electrical Characteristics

AC Characteristics (over recommended operating conditions unless otherwise noted)

Sym	Parameter	0°C		+25°C			+70°C		Units	Conditions
		Min	Max	Min	Typ	Max	Min	Max		
t _{WLE}	Time Width of \overline{LE}	150		150			150		ns	
t _{WDIN}	Time Width of D _{IN}	150		150			150		ns	
t _{SD}	Set Up Time Before \overline{LE} Rises	150		150			150		ns	
T _{ON}	Turn On Time		2.0			2.0		2.0	μs	V _{SIG} = V _{PP} -10V, R _{LOAD} = 10KΩ
T _{OFF}	Turn Off Time		2.0			2.0		2.0	μs	V _{SIG} = V _{PP} -10V, R _{LOAD} = 10KΩ
dv/dt	Maximum V _{SIG} Slew Rate		20			20		20	V/ns	
KO	Off Isolation	-30		-30	-33		-30		dB	F = 5MHz, Load = 1KΩ//15pF
		-45		-45	-50		-45			F = 7.5MHz, R _{LOAD} = 50Ω
K _{CR}	Switch Crosstalk	-45		-45			-45		dB	F = 5.0MHz, R _{LOAD} = 50Ω
I _{ID}	Output Switch Isolation Diode Current		300			300		300	mA	300ns pulse width, 2.0% duty cycle
C _{SG(OFF)}	Off Capacitance Switch to Gnd	5.0	17	5.0	12	17	5.0	17	pF	V _{SIG} = 0V, f = 1.0MHz
C _{SG(ON)}	On Capacitance Switch to Gnd	25	50	25	38	50	25	50	pF	V _{SIG} = 0V, f = 1.0MHz
+V _{SPK}	Output Voltage Spike				4.0				V	R _{LOAD} = 50Ω
-V _{SPK}					-4.0					

Logic Timing Diagram

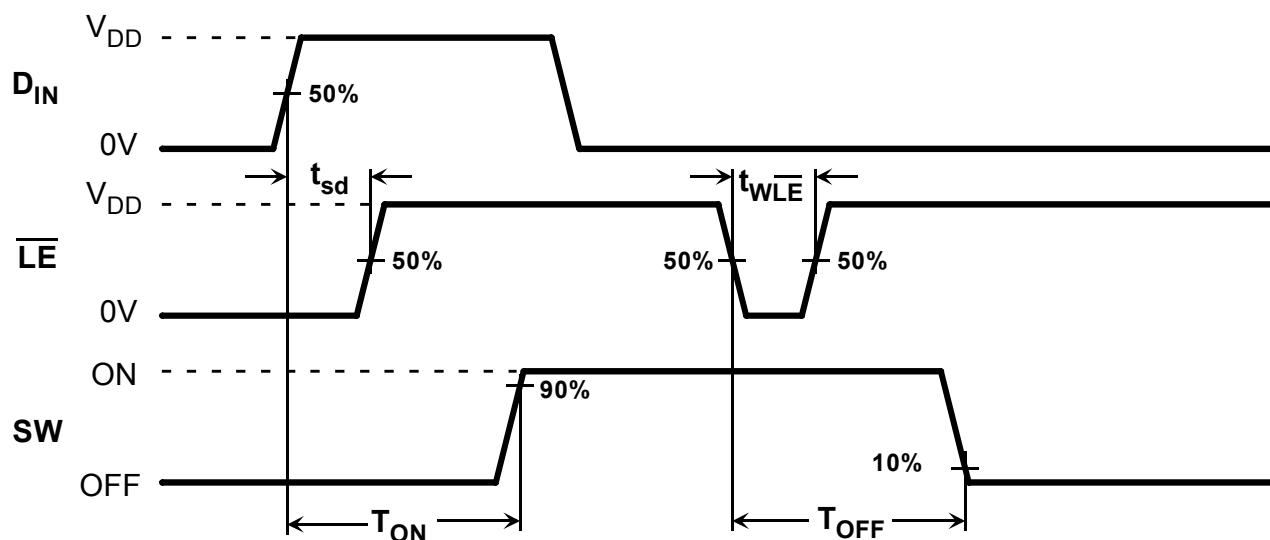

Test Circuits

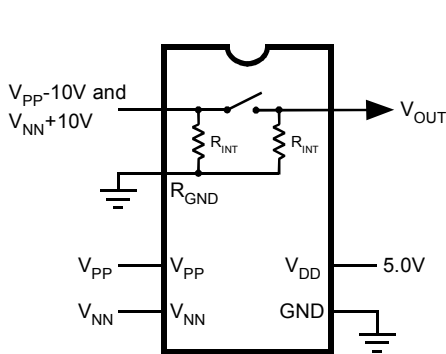

$$I_{SOL} = \frac{V_{OUT}}{R_{INT}}$$

Switch OFF Leakage

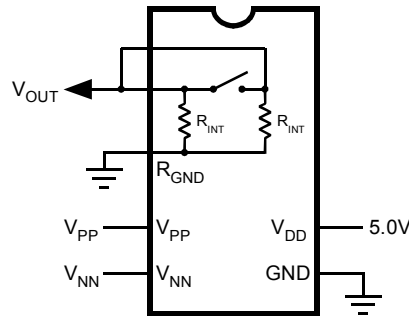

DC Offset ON/OFF

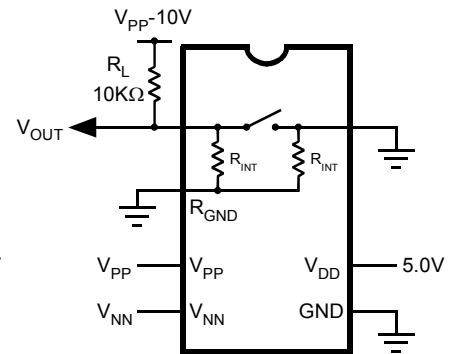

T_{ON}/T_{OFF}

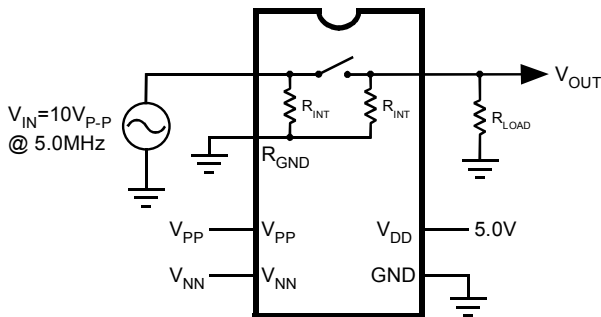

$$KO = 20 \text{Log} \frac{V_{OUT}}{V_{IN}}$$

Off Isolation

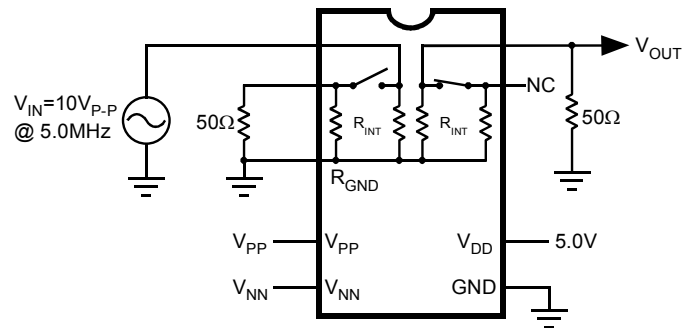

$$K_{CR} = 20 \text{Log} \frac{V_{OUT}}{V_{IN}}$$

Crosstalk

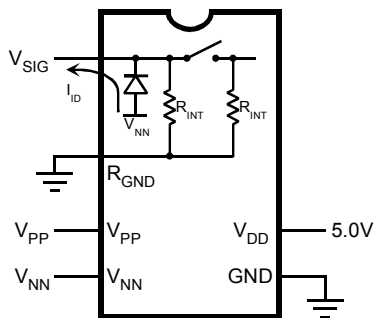

Isolation Diode Current

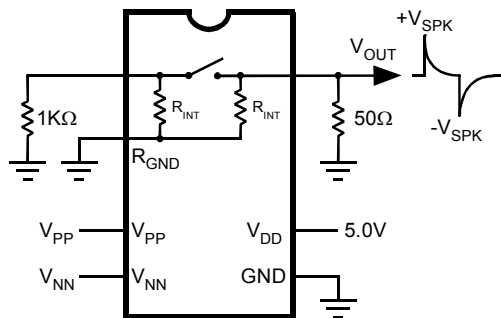

Output Voltage Spike

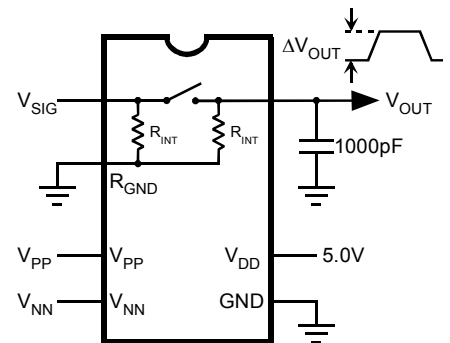

$$Q = 1000\text{pF} \times \Delta V_{OUT}$$

Charge Injection

Pin Configurations

48-lead TQFP

Pin	Function	Pin	Function
1	V _{NN}	25	SW10
2	N/C	26	SW10
3	V _{PP}	27	SW9
4	N/C	28	SW9
5	D _{IN1}	29	SW8
6	LE	30	SW8
7	D _{IN2}	31	SW7
8	N/C	32	SW7
9	N/C	33	SW6
10	V _{DD}	34	SW6
11	GND	35	SW5
12	N/C	36	SW5
13	R _{GND}	37	SW4
14	SW15	38	N/C
15	SW15	39	SW4
16	SW14	40	N/C
17	SW14	41	SW3
18	SW13	42	SW3
19	SW13	43	SW2
20	SW12	44	SW2
21	SW12	45	SW1
22	SW11	46	SW1
23	SW11	47	SW0
24	N/C	48	SW0

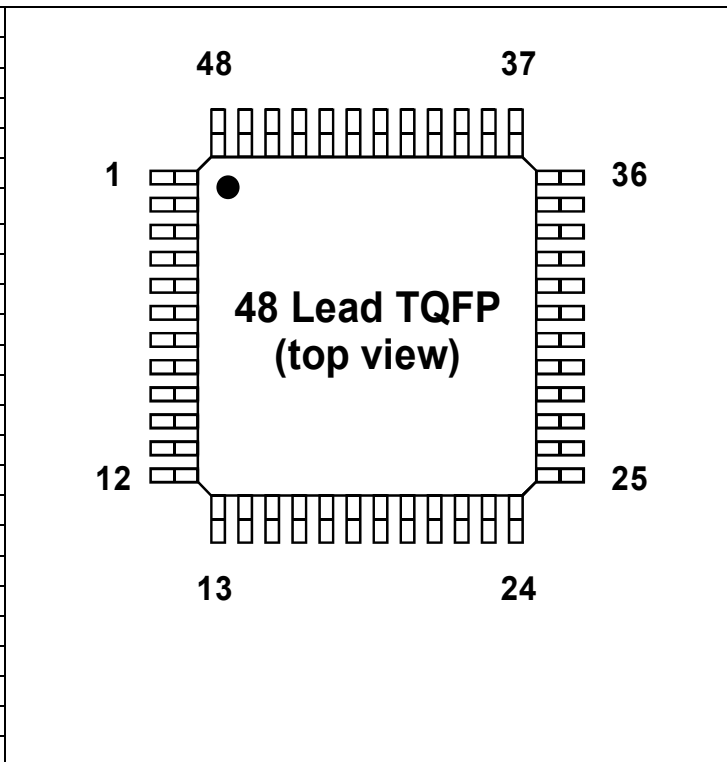

48-lead TQFP Package Dimensions

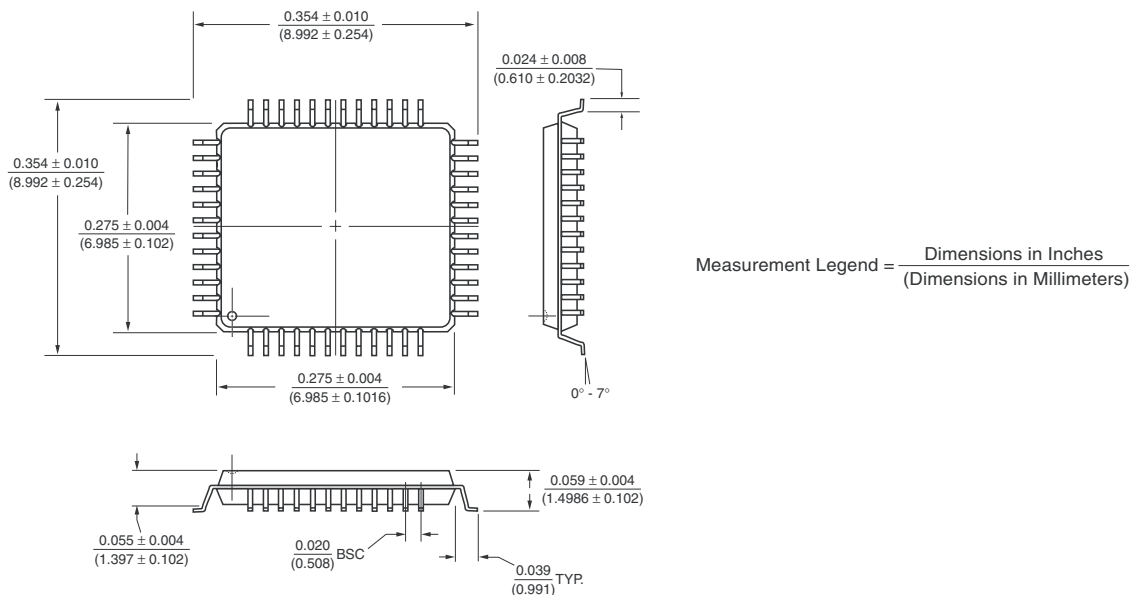

Supertex inc. does not recommend the use of its products in life support applications and will not knowingly sell its products for use in such applications unless it receives an adequate "products liability indemnification insurance agreement". **Supertex** does not assume responsibility for use of devices described and limits its liability to the replacement of the devices determined defective due to workmanship. No responsibility is assumed for possible omissions or inaccuracies. Circuitry and specifications are subject to change without notice. For the latest product specifications, refer to the **Supertex** website: <http://www.supertex.com>. For complete liability information on all **Supertex** products, refer to the most current databook or to the Legal/ Disclaimer page on the **Supertex** website.