

32-Channel Serial to Parallel Converter With High Voltage Push-Pull Outputs

Features

- ▶ HVCMOS® technology
- ▶ Operating output voltage up to +50/-40V
- ▶ Shift register speed 40MHz @ $V_{DD} = 5V$
- ▶ Data speed up to 160MHz @ $V_{DD} = 5V$
- ▶ 32 high voltage outputs
- ▶ CMOS/TTL compatible

Applications

- ▶ High speed print head driver
- ▶ LCD driver

General Description

The HV610 is a 32-channel high voltage, medium current driver IC. The outputs can be either at V_{PPS} , V_{NN} , HiZ, or HVGND.

Data is shifted through four parallel 8-bit shift registers on the low to high transition of the clock. A data output buffer is provided for cascading devices. Data is transferred to a 32-bit latch when logic level high is applied to the LE input. The CLR signal will reset both the shift register and the latch. Output states are controlled by POS, and NEG input signals, and by data in the latch. All outputs are tri-stated upon a logic high on the HiZ input signal.

Typical Application Diagram

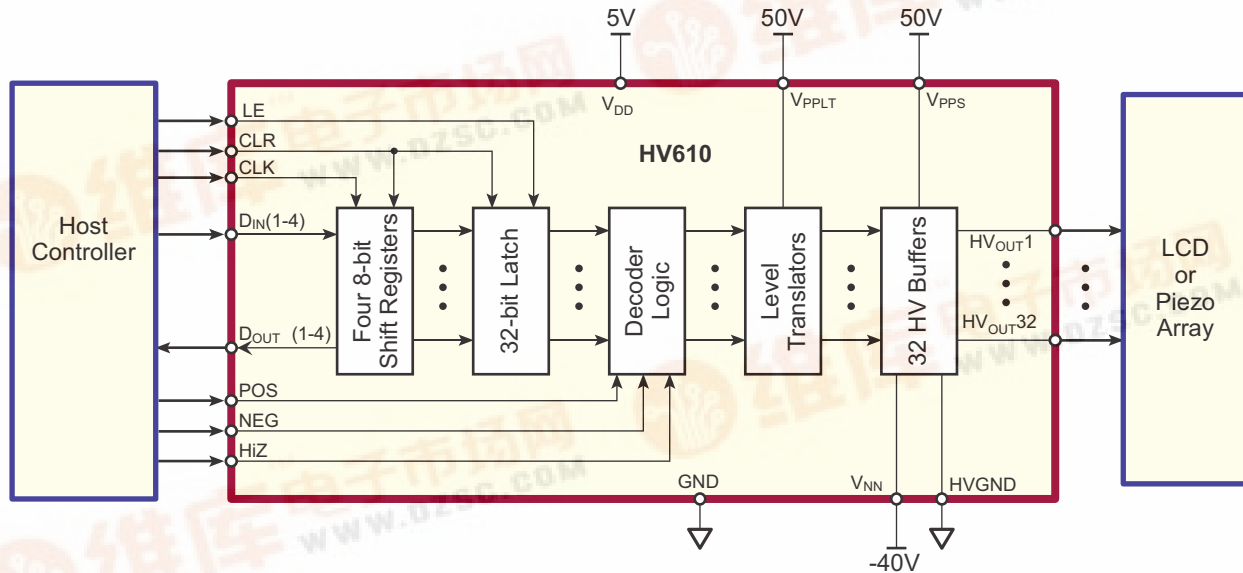

Ordering Information

Device	64-Lead TQFP 10x10x1.20mm body, 0.50mm pitch
HV610	HV610FG-G

-G indicates package is RoHS compliant ("Green")



Pin Configuration

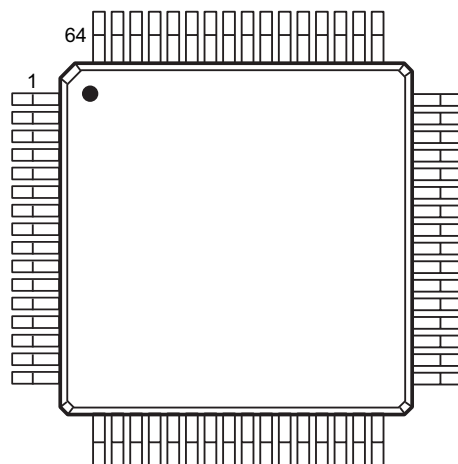

64-Lead TQFP
(top view)

Absolute Maximum Ratings

Parameter	Value
Supply voltage, V_{DD}	-0.5V to 6V
Supply voltage, V_{PP}	55V
Supply voltage, V_{NN}	-45V
Logic input levels	-0.5V to $V_{DD} + 0.5V$
Operating junction temperature range	-40°C to +125°C
Storage temperature range	-65°C +150°C

All voltages referenced to GND.

Product Marking

Top Marking

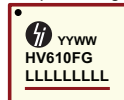

YY = Year Sealed
 WW = Week Sealed
 L = Lot Number
 C = Country of Origin*
 A = Assembler ID*
 — = "Green" Packaging

Bottom Marking

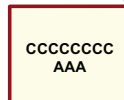

*May be part of top marking

Operating Supply Voltages and Temperatures (All voltages referenced to GND)

Symbol	Parameter	Min	Typ	Max	Units	Conditions
V_{DD}	Logic supply voltage	4.5	5.0	5.5	V	---
V_{PPS}	Positive high voltage supply for HV _{OUTPUT} source	25	-	50	V	For $f_{OUT} = 200kHz$
V_{PPLT}	Positive high voltage supply for level translators	47.5	-	50	V	---
V_{NN}	Negative high voltage supply	-15	-	-40	V	For $f_{OUT} = 200kHz$
HVGND	High voltage ground	-5	-	+5	V	---
V_{IH}	High-level input voltage	2.0	-	V_{DD}	V	---
V_{IL}	Low-level input voltage	0	-	0.8	V	---
T_A	Operating ambient temperature	-40	-	+85	°C	---

DC Electrical Characteristics

Over operating supply voltages and temperature, unless otherwise noted.

Symbol	Parameter	Min	Typ	Max	Units	Conditions	
I_{DD}	V_{DD} supply current	-	-	15	mA	$f_{CLK} = 40\text{MHz}$	
I_{DDQ}	V_{DD} quiescent supply current	-	-	0.1	mA	All logic inputs = V_{DD} or 0V	
		-	-	2.2		Per each input at TTL level	
I_{PPS}	V_{PPS} supply current	-	-	412	mA	CL = 700pF, $f_{OUT} = 200\text{kHz}$, all channels switching per HV_{OUT} waveform	
I_{PPSQ}	V_{PPS} quiescent supply current	-	-	100	μA	$V_{PPS} = 50\text{V}$, outputs static, $V_{PPLT} = 50\text{V}$	
I_{PPLT}	V_{PPLT} supply current	-	-	17	mA	$f_{OUT} = 200\text{kHz}$	
I_{PPLTQ}	V_{PPLTQ} quiescent supply current	-	-	100	μA	$V_{PPS} = 50\text{V}$, outputs static, $V_{PPLT} = 50\text{V}$	
I_{NN}	V_{NN} supply current	-	-	433	mA	CL = 700pF, $f_{OUT} = 200\text{kHz}$, all channels switching per HV_{OUT} waveform	
I_{NNQ}	V_{NN} quiescent supply current	-	-	100	μA	$V_{NN} = -40\text{V}$, outputs static	
I_{IH}	Logic input high current	-	-	50	μA	$V_{IH} = V_{DD}$	
		-	-	50	μA	$V_{IH} = 2.0\text{V}$	
I_{IL}	Logic input low current	-	-	-50	μA	$V_{IL} = 0\text{V}$	
		-	-	-50		$V_{IL} = 0.8\text{V}$	
I_{OL}	D_{OUT} low level logic sink current	-	-	12	mA	$D_{OUT} < 0.8\text{V}$	
I_{OH}	D_{OUT} high level logic source current	-	-	-12	mA	$D_{OUT} > 2.0\text{V}$	
V_{OH}	High level output	HV_{OUT}	$V_{PPS} - 10$	-	-	V	$I_{HV_{OUT}} = -35\text{mA}$, $V_{PPS} = +50\text{V}$, $V_{PPLT} = +50\text{V}$, $V_{NN} = -40\text{V}$
		D_{OUT}	$V_{DD} - 1.0$	-	-		$ID_{OUT} = -15\text{mA}$
V_{OL}	Low level output	HV_{OUT}	-	-	$V_{NN} + 10$	V	$I_{HV_{OUT}} = 35\text{mA}$, $V_{PPS} = +50\text{V}$, $V_{PPLT} = +50\text{V}$, $V_{NN} = -40\text{V}$
		D_{OUT}	-	-	1.0		$ID_{OUT} = 15\text{mA}$
V_{OMID}	Mid level output	-10	-	10	V	$I_{MID} = \pm 35\text{mA}$, $V_{PPS} = +50\text{V}$, $V_{PPLT} = +50\text{V}$, $V_{NN} = -40\text{V}$	
C_{DIN}	LV input capacitance	-	-	10	pF	---	

AC Electrical Characteristics

Over operating supply voltages and temperature, unless otherwise noted.

Symbol	Parameter	Min	Typ	Max	Units	Conditions
f_{CLK}	Clock frequency	0	-	40	MHz	0 to V_{DD} clock input
		0	-	33		0 to 2.0V clock input
f_{OUT}	Output switching frequency switching waveform	-	-	200	KHz	CL = 700pF, 5% to 95% $V_{PPLT} = 50\text{V}$
t_C	Clock high/low pulse width	10	-	-	ns	0 - V_{DD} logic signals
		10	-	-		0 - 2.0V logic signals

AC Electrical Characteristics (cont.)

Over operating supply voltages and temperature, unless otherwise noted.

Symbol	Parameter	Min	Typ	Max	Units	Conditions
t_{SUD}	Data setup time before clock rises	12.5	-	-	ns	0 - V_{DD} logic signals
		15	-	-		0 - 2V logic signals
t_{HD}	Data hold time after clock rises	2	-	-	ns	---
t_{SUC}	LE from CLK setup time	15	-	-	ns	---
t_{LE}	LE pulse width	10	-	-	ns	---
t_{WOC}	Width of CLR, POS, NEG, HiZ pulses	500	-	-	ns	---
t_{DHIZ}	HiZ input to HV_{OUT} HiZ state delay	-	-	400	ns	---
t_{CLRH}	CLR input to HV_{OUT} delay	-	-	1.1	μ s	---
t_{DCLR}	CLR input to D_{OUT} delay	5	-	50	ns	---
t_{DD}	Clock positive edge to D_{OUT} delay	2.5	-	12.5	ns	$C_{LDOUT} = 30pF$
t_{PHV}	Delay time from inputs for HV_{OUT} to start rise/fall	-	-	500	ns	$V_{PPLT} = 50V$
t_{HIZ}	Output HiZ state before each transition	-	-	100	ns	$V_{PPLT} = 50V$
t_{HR}	Time for output to go from 95% of V_{PPS}/V_{NN} to 99% of V_{PPS}/V_{NN}	-	-	0.5	μ s	$C_L = 700pF$, HV_{GND} to V_{PPS} , or HV_{GND} to V_{NN} transitions
		-	-	1.0	μ s	$C_L = 700pF$, V_{PPS} to V_{NN} , or V_{NN} to V_{PPS} transitions
t_{HG}	Time for output to go from $HV_{GND} \pm 1V$ to within 1% of HV_{GND}	-	-	0.5	μ s	$C_L = 700pF$, V_{NN} to HV_{GND} , or V_{PPS} to HV_{GND} transitions
t_{RPN} , t_{FPN}	Output rise/fall time (per function table 3)	-	-	1.6	μ s	$C_L = 700pF$, $V_{PPLT} = 50V$, transitions between V_{PPS} and V_{NN}
t_{RR} , t_{FR}	Output rise/fall time from HV_{GND} to 95% of V_{PPS}/V_{NN}	-	-	0.9	μ s	$C_L = 700pF$, $V_{PPLT} = 50V$
t_{RG} , t_{FG}	Output rise/fall time from 95% of V_{PPS}/V_{NN} to $HV_{GND} \pm 1V$	-	-	0.9	μ s	$C_L = 700pF$, $V_{PPLT} = 50V$
t_{ORPN} , t_{OFFN}	Delay time from input edges to 95% of HV_{OUT} rise/fall (per function table 3)	-	-	1.8	μ s	$C_L = 700pF$, $V_{PPLT} = 50V$, transitions between V_{PPS} and V_{NN}
t_{ORG} , t_{OFG}	Delay time from input edges to 95% of HV_{OUT} rise/fall from HV_{GND} to V_{PPS} or V_{NN} , or from V_{PPS}/V_{NN} to within $\pm 1V$ of HV_{GND}	-	-	1.1	μ s	$C_L = 700pF$, $V_{PPLT} = 50V$, transitions between V_{PPS}/V_{NN} and HV_{GND}
θ_{JA}	Thermal resistance, junction to ambient	-	59	-	$^{\circ}C/W$	Mounted on 4-layer PCB board

Function Table 1 (S/R and D_{OUT} of S/R one of four)

Inputs				Outputs	
Data (n-1)	CLK	CLR	LE, POS, NEG, HiZ	S/R1..8(n)*	Data Out
L or H	L to H	L	X	S/R1 = D _{IN} (n-1) S/R2 = S/R1(n-1) . . S/R8 = S/R7(n-1)	S/R8(n-1)
X	L	L	X	S/R1..8(n-1)	D _{OUT} (n-1)
X	H	L	X	S/R1..8(n-1)	D _{OUT} (n-1)
X	X	H	X	L	L

Notes:

H = high level, L = low level, X = irrelevant,

*D_{IN}1 to D_{IN}4 => 1st S/R1..8 to 4th S/R1..8,

*1st S/R1..8 to 4th S/R1..8 = D1..D8, D9..D16, D17..D24, D25..D32

Function Table 2 (Latch)

Inputs				Outputs
D1..32	LE	CLR	CLK, POS, NEG, HiZ	LD1..32
X	X	H	X	L
L or H	H	L	X	L or H
X	L	L	X	Unchanged

Function Table 3 (HV outputs)

Inputs								Outputs
POS	NEG	HiZ	CLK	LE	CLR	D _{IN}	LD1..32	HV _{OUT} 1..32
X	X	H	X	X	X	X	X	HiZ
H	H	L	X	L	L	X	H	HiZ
L	L	L	X	L	L	X	X	HVGND
X	X	L	X	L	L	X	L	HVGND
L	H	L	X	L	L	X	H	V _{NN}
H	L	L	X	L	L	X	H	V _{PPS}
X	X	L	X	X	H	X	X	HVGND

Functional Block Diagram

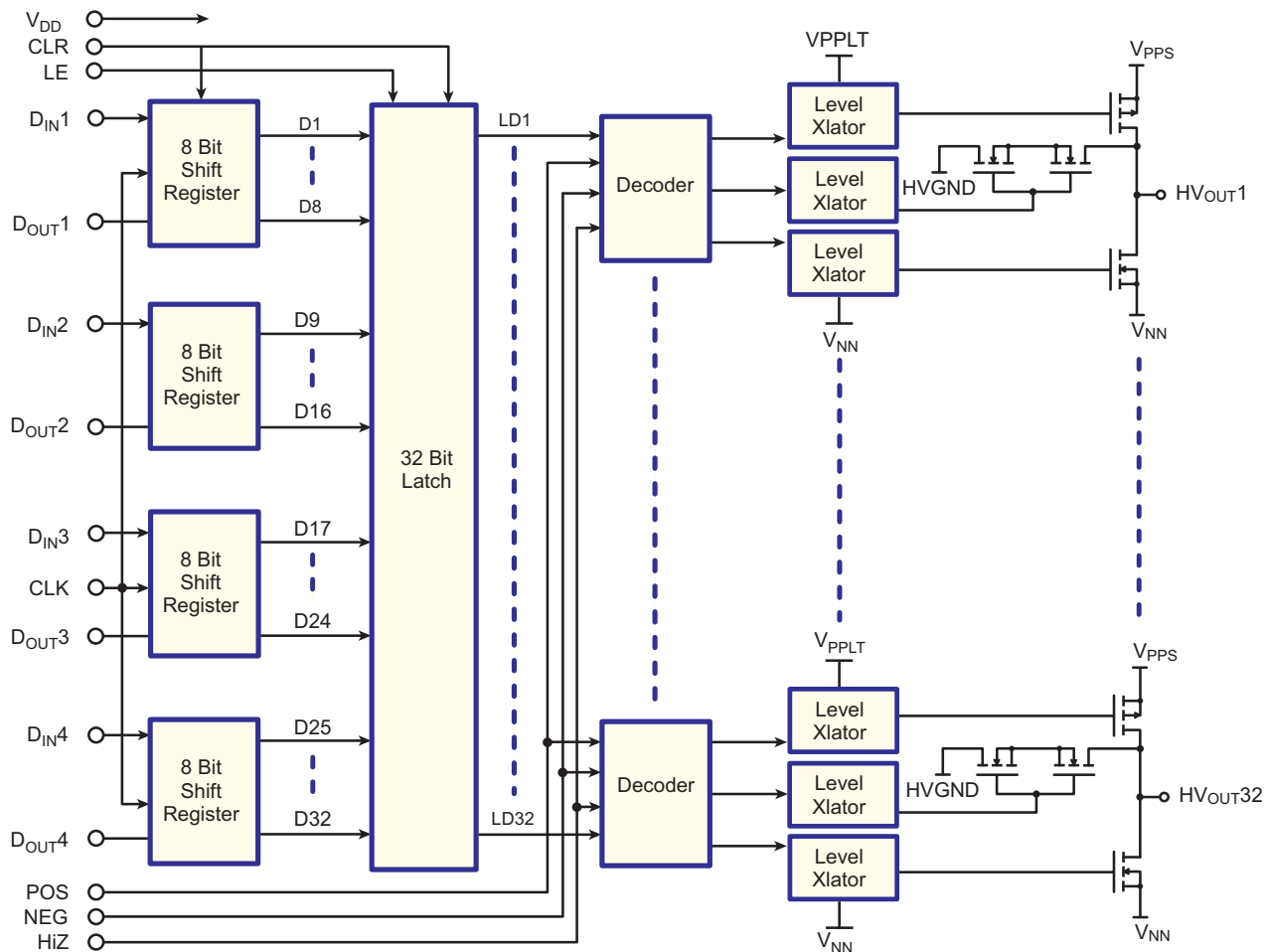

Input and Output Equivalent Circuits

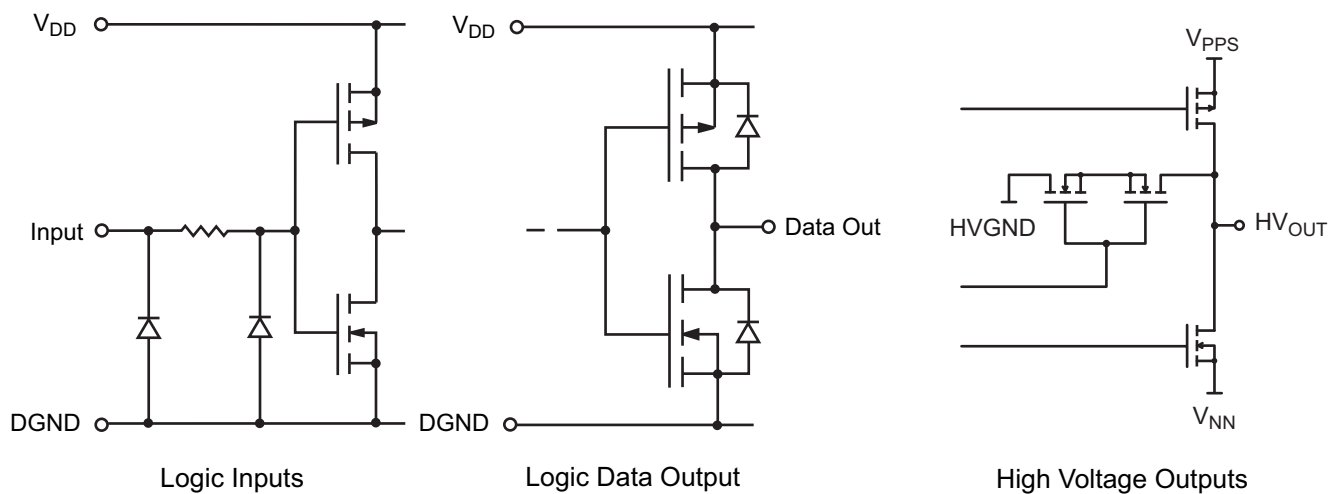

TQFP Pin Description

Pin #	Function	Pin #	Function	Pin #	Function	Pin #	Function
1	V_{NN}	17	HVGND	33	D_{IN2}	49	D_{OUT1}
2	HV_{OUT23}	18	V_{PPS}	34	D_{IN3}	50	V_{PPLT}
3	HV_{OUT22}	19	HV_{OUT9}	35	D_{IN4}	51	HVGND
4	HV_{OUT21}	20	HV_{OUT8}	36	DGND	52	V_{PPS}
5	HV_{OUT20}	21	HV_{OUT7}	37	POS	53	V_{NN}
6	HV_{OUT19}	22	HV_{OUT6}	38	NEG	54	HV_{OUT32}
7	HV_{OUT18}	23	HV_{OUT5}	39	HIZ	55	HV_{OUT31}
8	HV_{OUT17}	24	HV_{OUT4}	40	CLK	56	HV_{OUT30}
9	HV_{OUT16}	25	HV_{OUT3}	41	CLR	57	HV_{OUT29}
10	HV_{OUT15}	26	HV_{OUT2}	42	LE	58	HV_{OUT28}
11	HV_{OUT14}	27	HV_{OUT1}	43	V_{DD}	59	HV_{OUT27}
12	HV_{OUT13}	28	V_{NN}	44	DGND	60	HV_{OUT26}
13	HV_{OUT12}	29	V_{PPS}	45	NC	61	HV_{OUT25}
14	HV_{OUT11}	30	HVGND	46	D_{OUT4}	62	HV_{OUT24}
15	HV_{OUT10}	31	V_{PPLT}	47	D_{OUT3}	63	V_{PPS}
16	V_{NN}	32	D_{IN1}	48	D_{OUT2}	64	HVGND

Power-Up / Power-Down Sequence

Step	Description
1	Connect DGND and HVGND
2	Apply V_{DD}
3	Set all inputs (Data, CLK, LE, POS, NEG, HiZ, etc.) to a known state
4	Apply V_{NN}
5	Apply V_{PPLT}
6	Apply V_{PPS}

Power-down sequence should be the reverse of the above. To insure the safest power-up/down sequence, the intervals between power-up signals should be between 1msec to 10msec, after the previous signal changed 95% of its final level.

64-Lead TQFP Package Outline (FG)

10x10mm body, 1.2mm height (max.), 0.50mm pitch

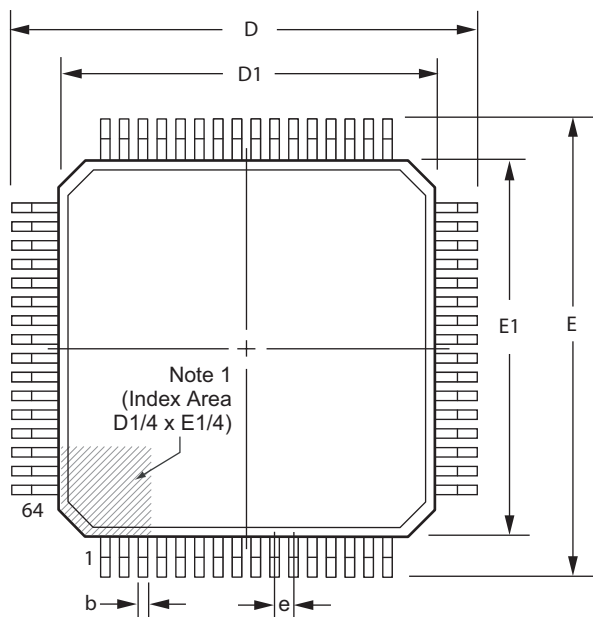

Top View

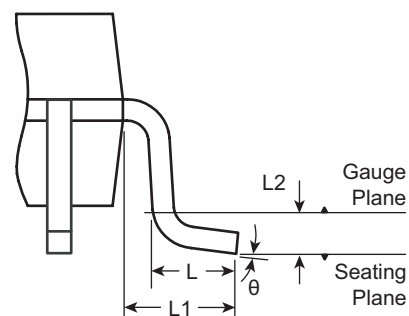

View B

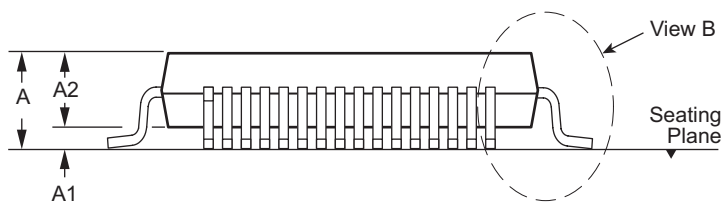

Side View

Note 1:

A Pin 1 identifier must be located in the index area indicated. The Pin 1 identifier may be either a mold, or an embedded metal or marked feature.

Symbol	A	A1	A2	b	D	D1	E	E1	e	L	L1	L2	θ	
Dimension (mm)	MIN	1.00	0.05	0.95	0.17	11.80	9.80	11.80	9.80	0.50 BSC	1.00 REF	0.25 BSC	0°	
	NOM	-	-	1.00	0.22	12.00	10.00	12.00	10.00				0.60	3.5°
	MAX	1.20	0.15	1.05	0.27	12.20	10.20	12.20	10.20				0.75	7°

JEDEC Registration MS-026, Variation ACD, Issue D, Jan. 2001.

Drawings not to scale.

(The package drawings in this data sheet may not reflect the most current specifications. For the latest package outline information go to <http://www.supertex.com/packaging.html>.)

Supertex inc. does not recommend the use of its products in life support applications, and will not knowingly sell its products for use in such applications, unless it receives an adequate "product liability indemnification insurance agreement". Supertex does not assume responsibility for use of devices described and limits its liability to the replacement of the devices determined defective due to workmanship. No responsibility is assumed for possible omissions or inaccuracies. Circuitry and specifications are subject to change without notice. For the latest product specifications, refer to the Supertex website: <http://www.supertex.com>.