

IS34C02B

2K-bit 2-WIRE SERIAL CMOS EEPROM with Permanent and Reversible Write-Protection

ADVANCED INFORMATION
APRIL 2006

FEATURES

- Two-Wire Serial Interface, I²C™ compatible
 - Bidirectional data transfer protocol
 - 400 kHz (2.5V) and 100 KHz (1.7V) compatibility
- Organization:
 - 256 x 8-bit
- Data Protection Features
 - Write Protect Pin
 - Permanent Software Protection
 - Reversible Software Protection
- 16-Byte Page Write Buffer
 - Partial Page-writes permitted
- Low Power CMOS Technology
 - Active Current less than 3 mA (3.6V)
 - Standby Current less than 1 μA (1.7V)
 - Standby Current less than 2 μA (3.6V)
- Low Voltage Operation
 - IS34C02B-2: Vcc = 1.7V to 3.6V
- Random or Sequential Read Modes
- Filtered Inputs for Noise Suppression
- Self timed Write cycle (5ms max.)
- High Reliability
 - Endurance: 1,000,000 Cycles
 - Data Retention: 40 Years
- Industrial temperature range
- 8-pin TSSOP and DFN (leadless array)
- Lead-free available

DESCRIPTION

The IS34C02B is an electrically erasable PROM device that uses the industry-standard I²C communication protocol. The IS34C02B contains a non-volatile memory array of 2,048-bits (256K x 8 bytes), and is further subdivided into 16 pages of 16 bytes each for Page-write mode. The device operates over the voltage range of 1.7V to 3.6V to satisfy the voltage requirements of DDR2, DDR1, and many other specifications. In normal Read or Write operations, a master device communicates with the EEPROM via the two wires Serial Clock and Serial Data. During application system boot-up, it may be necessary to read out the contents of the IS34C02B that pertain to the configuration of a DRAM module. If the module manufacturer wishes to safeguard this memory content, the first half of the array can be write-protected with either a permanent or reversible software command, or the entire array can be write-protected with the WP input pin. The IS34C02B has three address pins, allowing up to eight devices (or memory modules) to be uniquely accessible in a system. To minimize board real-estate, IS34C02B is available in two space-saving packages: TSSOP(8), and DFN(8). All these features make the device ideal for use as a Serial Presence Detect (SPD) EEPROM in various types of memory modules.

FUNCTIONAL BLOCK DIAGRAM

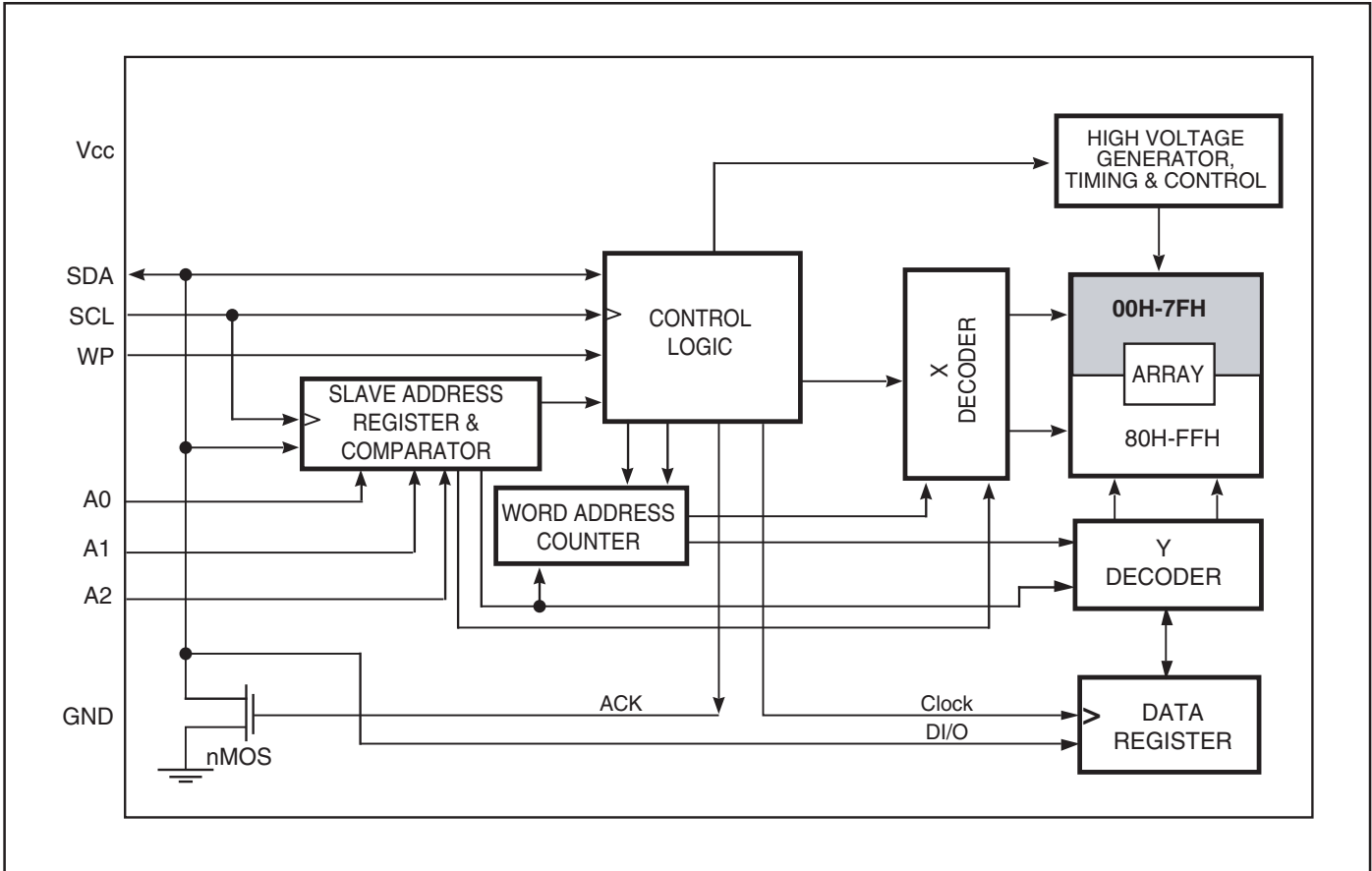

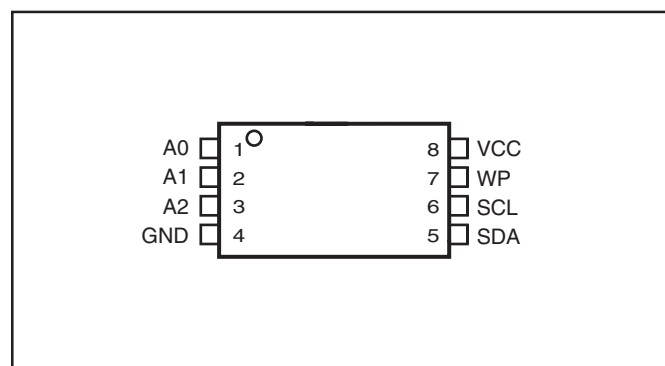
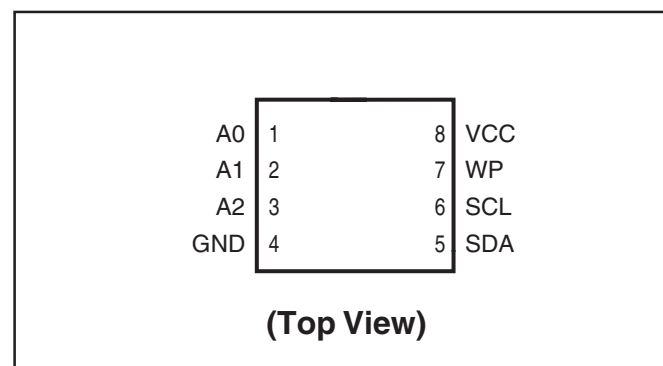
PIN CONFIGURATION
8-Pin TSSOP

8-pad DFN

PIN DESCRIPTIONS

A0-A2	Address Inputs
SDA	Serial Address/Data I/O
SCL	Serial Clock Input
WP	Write Protect Input
Vcc	Power Supply
GND	Ground

SCL

This input clock pin is used to synchronize the data transfer to and from the device.

SDA

The SDA is a Bi-directional pin used to transfer addresses and data into and out of the device. The SDA pin is an open drain output and can be wire Or'ed with other open drain or open collector outputs. The SDA bus *requires* a pullup resistor to Vcc.

A0, A1, A2

The A0, A1, and A2 are the device address inputs that are hardwired or left unconnected for hardware flexibility. When pins are hardwired, as many as eight devices may be addressed on a single bus system. When the pins are not hardwired, the default values of A0, A1, and A2 are zero.

WP

WP is the Write Protect pin. If the WP pin is tied to Vcc, the entire array becomes Write Protected, and software write-protection cannot be initiated. When WP is tied to GND or left floating, normal read/write operations are allowed to the device. If the device has already received a write-protection command, the memory in the range of 00h-7Fh is read-only regardless of the setting of the WP pin.

DEVICE OPERATION

The IS34C02B features a serial communication and supports a bi-directional 2-wire bus transmission protocol called I²C™.

2-WIRE BUS

The two-wire bus is defined as a Serial Data line (SDA), and a Serial Clock line (SCL). The protocol defines any device that sends data onto the SDA bus as a transmitter, and the receiving device as a receiver. The bus is controlled by Master device which generates the SCL, controls the bus access and generates the Stop and Start conditions. The IS34C02B is the Slave device on the bus.

The Bus Protocol:

- Data transfer may be initiated only when the bus is not busy
- During a data transfer, the SDA line must remain stable whenever the SCL line is high. Any changes in the SDA line while the SCL line is high will be interpreted as a Start or Stop condition.

The state of the SDA line represents valid data after a Start condition. The SDA line must be stable for the duration of the High period of the clock signal. The data on the SDA line may be changed during the Low period of the clock signal. There is one clock pulse per bit of data. Each data transfer is initiated with a Start condition and terminated with a Stop condition.

Start Condition

The Start condition precedes all commands to the device and is defined as a High to Low transition of SDA when SCL is High. The IS34C02B monitors the SDA and SCL lines and will not respond until the Start condition is met.

Stop Condition

The Stop condition is defined as a Low to High transition of SDA when SCL is High. All operations must end with a Stop condition.

Acknowledge (ACK)

After a successful data transfer, each receiving device is required to generate an ACK. The Acknowledging device pulls down the SDA line.

Reset

The IS34C02B contains a reset function in case the 2-wire bus transmission is accidentally interrupted (eg. a power loss), or needs to be terminated mid-stream. The reset is caused when the Master device creates a Start condition. To do this, it may be necessary for the Master device to monitor the SDA line while cycling the SCL up to nine times. (For each clock signal transition to High, the Master checks for a High level on SDA.)

Standby Mode

Power consumption is reduced in standby mode. The IS34C02B will enter standby mode: a) At Power-up, and remain in it until SCL or SDA toggles; b) Following the Stop signal if no write operation is initiated; or c) Following any internal write operation

DEVICE ADDRESSING

The Master begins a transmission by sending a Start condition. The Master then sends the address of the particular Slave devices it is requesting. The Slave device (Fig. 5) address is 8 bits.

The four most significant bits of the Slave device address are fixed as 1010 for normal read/write operations, and 0110 for permanent write-protection operations.

This device has three address bits (A1, A2, and A0) that allow up to eight IS34C02B devices to share the 2-wire bus. Upon receiving the Slave address, the device compares the three address bits with the hardwired A2, A1, and A0 input pins to determine if it is the appropriate Slave. If any of the A2 - A0 pins is neither biased to High nor Low, internal circuitry defaults the value to Low.

The last bit of the Slave address specifies whether a Read or Write operation is to be performed. When this bit is set to 1, a Read operation is selected, and when set to 0, a Write operation is selected.

After the Master transmits the Start condition and Slave address byte (Fig. 5), the appropriate 2-wire Slave (eg. IS34C02B) will respond with ACK on the SDA line. The Slave will pull down the SDA on the ninth clock cycle, signaling that it received the eight bits of data. The selected IS34C02B then prepares for a Read or Write operation by monitoring the bus.

WRITE OPERATION

Byte Write

In the Byte Write mode, the Master device sends the Start condition and the Slave address information (with the R/\bar{W} set to Zero) to the Slave device. After the Slave generates an ACK, the Master sends a byte address that is written into the address pointer of the IS34C02B. After receiving another ACK from the Slave, the Master device transmits the data byte to be written into the address memory location. The IS34C02B acknowledges once more and the Master generates the Stop condition, at which time the device begins its internal programming cycle. While this internal cycle is in progress, the device will not respond to any request from the Master device.

Page Write

The IS34C02B is capable of 16-byte Page-Write operation. A Page-Write is initiated in the same manner as a Byte Write, but instead of terminating the internal Write cycle after the first data byte is transferred, the Master device can transmit up to 15 more bytes. After the receipt of each data byte, the IS34C02B responds immediately with an ACK on SDA line, and the four lower order data byte address bits are internally incremented by one, while the higher order bits of the data byte address remain constant. If a byte address is incremented from the last byte of a page, it returns to the first byte of that page. If the Master device should transmit more than 16 bytes prior to issuing the Stop condition, the address counter will “roll over,” and the previously written data will be overwritten. Once all 16 bytes are received and the Stop condition has been sent by the Master, the internal programming cycle begins. At this point, all received data is written to the IS34C02B in a single Write cycle. All inputs are disabled until completion of the internal Write cycle.

Acknowledge (ACK) Polling

The disabling of the inputs can be used to take advantage of the typical Write cycle time. Once the Stop condition is issued to indicate the end of the host's Write operation, the IS34C02B initiates the internal Write cycle. ACK polling can be initiated immediately. This involves issuing the Start condition followed by the Slave address for a Write operation. If the IS34C02B is still busy with the Write operation, no No Acknowledge (NoACK) will be returned. If the IS34C02B has completed the Write operation, an ACK will be returned and the host can then proceed with the next Read or Write operation.

WRITE PROTECTION

Hardware Write Protection

The IS34C02B has two forms of software write protection and one form of hardware write protection. The hardware write protection is enabled when the WP input is held High. In this case, the entire array of the IS34C02B is read-only regardless of the status of the software protection. The hardware protection is disabled when the WP input is held Low or is floating. In this case, the upper half of the array (80h-FFh) can be modified by a valid Write command, and the lower half of the array (00h-7Fh) can be modified only if software write protection has not been enabled.

Reversible Software Write Protection

There is a non-volatile flag for each of the two forms of software write protection. When the bit value for either flag or both flags is 1, it is not possible to modify the contents of the lower 128 bytes of the array (00h-7Fh). If the bit value for both flags is 0, it is possible to modify this half of the array with a valid Write command, assuming WP is held Low or is floating. The device is shipped with both flags cleared. One of those flags is the Reversible Software Write Protection (RSWP) flag, and can be changed with the Set RSWP and Clear RSWP commands. The flag can also be verified without being changed with a Read SWP command. In order to set, clear or read the RSWP, the IS34C02B input pins must be as follows: A0 must be held to an extra high voltage of VHV (see DC Characteristics), while A2 and A1 must be set High, Low, or left floating, depending on the desired command (see Figure 5). Once these input conditions are met, a command can be issued to the device.

The reversible software commands are initiated similarly to a normal byte write operation; however, the slave device address begins with the bit values 0110. The next three bits are A2 = 0, A1 = 0 or 1, and A0 = 1, so that they logically match the values on the input pins. If the last bit of the slave device address (R/\bar{W}) is 0, the RSWP flag can be Cleared or Set. If R/\bar{W} is 1, the flag can be verified with the Read SWP command. Following this bit, the device responds with either ACK or NoACK, depending on the exact command and the flag status (see Table 1: Reversible Instructions). To complete the

Set RSWP or Clear RSWP command, the Master must transmit a dummy address byte, a dummy data byte, and a Stop signal. To actually modify the RSWP flag, WP should be held Low or be floating during entire command sequence. Before resuming any other command, the internal write cycle time should be observed. To complete the Read SWP Status or Read CWP Status command, the Master can transmit a Stop signal after the ACK/NoACK. The WP input is not evaluated for the Read SWP Status or Read CSP Status commands.

Permanent Software Write Protection

The IS34C02B contains a permanent software write protection (PSWP) feature. If the non-volatile PSWP flag has a bit value of 1, the array region of 00h-7Fh is protected from modification. If the PSWP flag has a bit value of 0, the write protection for the lower half of the array is determined solely by the statuses of RSWP and the WP input. After the PSWP flag is set to 1 via the Permanent Write Protect command, the protected area becomes irreversibly read-only despite power removal and re-application on the device. Once enabled, the permanent protection is independent of the status of the WP pin.

The Permanent Software Write Protect command is initiated similarly to a normal byte write operation; however, the slave device address begins with the bit values of 0110 (see Figure 5). The following three bits are A2-A0, so that they logically match the values on the input pins. The last bit of the slave address (R/\overline{W}) is 0. The IS34C02B responds with either ACK or NoACK, depending on the flag status (see Table 1: Permanent Instructions). Assuming an ACK is received, Master then must complete the sequence by transmitting a dummy address byte, dummy data byte, and a Stop signal (see Figure 11). The WP pin should be held Low or left floating during the entire command. Before resuming any other command, the internal write cycle should be observed.

The status of the PSWP can be safely determined without any changes by transmitting the same slave address as above, but with the last bit (R/\overline{W}) set to 1 (see Figure 12). If the PSWP has been set, the IS34C02B will not acknowledge any slave address starting with bits 0110 (see Figure 5). To complete the command, the Master can transmit a Stop signal after the ACK/NoACK.

IS34C02B

TABLE 1

Normal Instructions

Command	PSWP (Permanent)	RSWP (Reversible)	WP ¹	ACK Command	Address	ACK Address	Data Byte	Data Byte ACK	Write Cycle
Read	X	X	X	ACK	00h-FFh	ACK	Data Byte	ACK	No
Write	0	0	0	ACK	00h-FFh	ACK	Data Byte	ACK	Yes
Write	X	X	1	ACK	00h-FFh	ACK	Data Byte	ACK	No
Write	1	X	X	ACK	00h-7Fh	ACK	Data Byte	ACK	No
Write	X	1	X	ACK	00h-7Fh	ACK	Data Byte	ACK	No
Write	X	X	0	ACK	80h-FFh	ACK	Data Byte	ACK	Yes

Permanent Instructions

Command	PSWP (Permanent)	RSWP (Reversible)	WP ¹	ACK Command	Address	ACK Address	Data Byte	Data Byte ACK	Write Cycle
Read PSWP Status ⁴	0	X	X	ACK	Dummy Address	ACK	Dummy Byte	ACK	No
Read PSWP Status	1	X	X	NoACK	—	—	—	—	No
Set PSWP	0	X	0	ACK	Dummy Address	ACK	Dummy Byte	ACK	Yes
Set PSWP	1	X	0	NoACK	—	—	—	—	No
Set PSWP	0	X	1	ACK	Dummy Address	ACK	Dummy Byte	ACK	No
Set PSWP	1	X	1	NoACK	—	—	—	—	No

Reversible Instructions

Command	PSWP (Permanent)	RSWP (Reversible)	WP ¹	ACK Command	Address	ACK Address	Data Byte	Data Byte ACK	Write Cycle
Read SWP Status ⁴	X	0	X	ACK	Dummy Address	ACK	Dummy Byte	ACK	No
Read SWP Status	X	1	X	NoACK	—	—	—	—	No
Read CWP Status ^{3,4}	0	X	X	ACK	Dummy Address	ACK	Dummy Byte	ACK	No
Read CWP Status ³	1	X	X	NoACK	—	—	—	—	No
Set RSWP	X	0	0	ACK	Dummy Address	ACK	Dummy Byte	ACK	Yes
Set RSWP	X	1	0	NoACK	—	—	—	—	No
Set RSWP	X	0	1	ACK	Dummy Address	ACK	Dummy Byte	ACK	No
Set RSWP	X	1	1	NoACK	—	—	—	—	No
Clear RSWP	0	X	0	ACK	Dummy Address	ACK	Dummy Byte	ACK	Yes
Clear RSWP	1	X	0	NoACK	—	—	—	—	No
Clear RSWP	0	X	1	ACK	Dummy Address	ACK	Dummy Byte	ACK	No
Clear RSWP	1	X	1	NoACK	—	—	—	—	No

Notes:

1. WP = 1 if input level is High. WP = 0 if input level is GND or floating.
2. X = Don't Care.
3. Read CWP Status yields the same result as Read PSWP Status.
4. Read out Don't Care Dummy Address and Dummy Data is optional.

READ OPERATION

Read operations are initiated in the same manner as Write operations, except that the (R/\overline{W}) bit of the Slave address is set to “1”. There are three Read operation options: current address read, random address read and sequential read.

Current Address Read

The IS34C02B contains an internal address counter which maintains the address of the last byte accessed, incremented by one. For example, if the previous operation is either a Read or Write operation addressed to the address location n , the internal address counter would increment to address location $n+1$. When the IS34C02B receives the Device Addressing Byte with a Read operation (R/\overline{W} bit set to “1”), it will respond an ACK and transmit the 8-bit data byte stored at address location $n+1$. The Master should not acknowledge the transfer but should generate a Stop condition so the IS34C02B discontinues transmission. If the last byte of the memory was the previous access, the data from location '0' will be transmitted. (Refer to Figure 8. Current Address Read Diagram.)

Random Address Read

Selective Read operations allow the Master device to select at random any memory location for a Read operation. The Master device first performs a 'dummy' Write operation by sending the Start condition, Slave address and word address of the location it wishes to read. After the IS34C02B acknowledges the word address, the Master device resends the Start condition and the Slave address, this time with the R/\overline{W} bit set to one. The IS34C02B then responds with its ACK and sends the data requested. The Master device does not send an ACK but will generate a Stop condition. (Refer to Figure 9. Random Address Read Diagram.)

Sequential Read

Sequential Reads can be initiated as either a Current Address Read or Random Address Read. After the IS34C02B sends the initial byte sequence, the Master device responds with an ACK indicating it requires additional data from the IS34C02B. The IS34C02B continues to output data for each ACK received. The Master device terminates the sequential Read operation by pulling SDA High (no ACK) indicating the last data byte to be read, followed by a Stop condition.

The data output is sequential, with the data from address n followed by the data from address $n+1$, ... etc. The address counter increments by one automatically, allowing the entire memory contents to be serially read during sequential Read operations. When the memory address boundary 255 is reached, the address counter “rolls over” to address 0, and the IS34C02B continues to output data for each ACK received. (Refer to Figure 10. Sequential Read Operation Starting with a Random Address Read Diagram.)

Figure 1. Typical System Bus Configuration

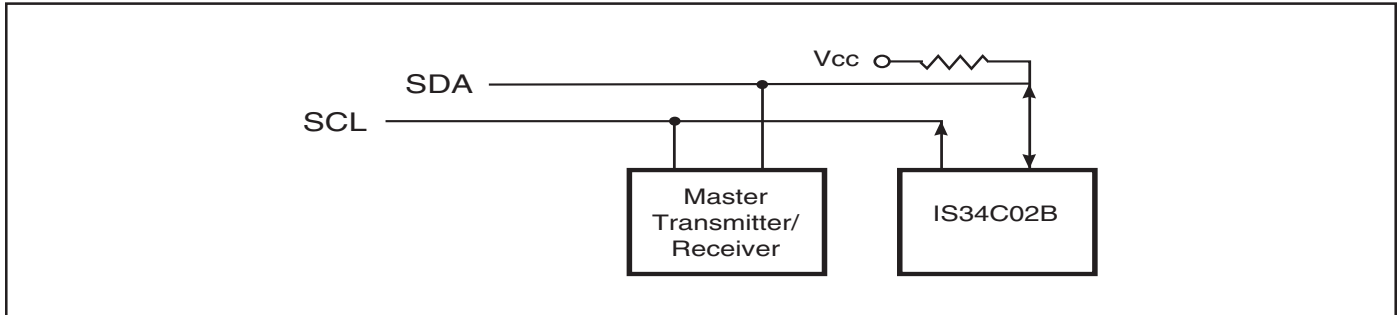

Figure 2. Output Acknowledge

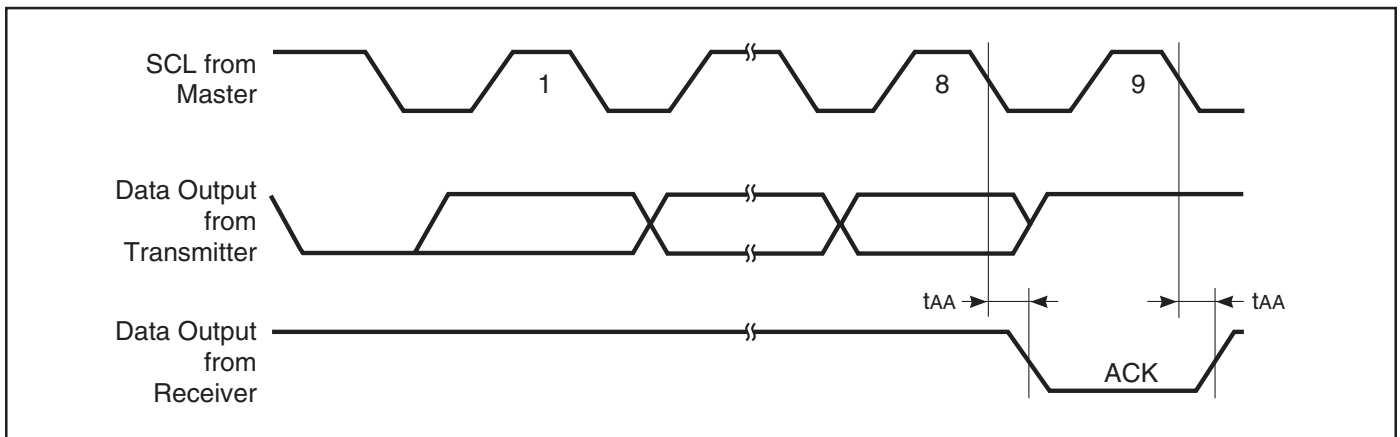

Figure 3. Start and Stop Conditions

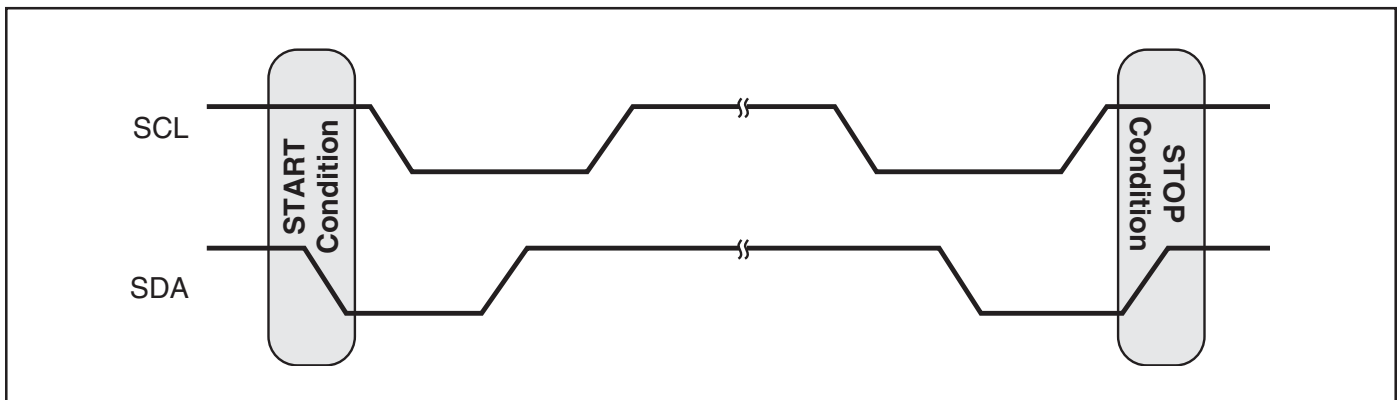

Figure 4. Data Validity Protocol

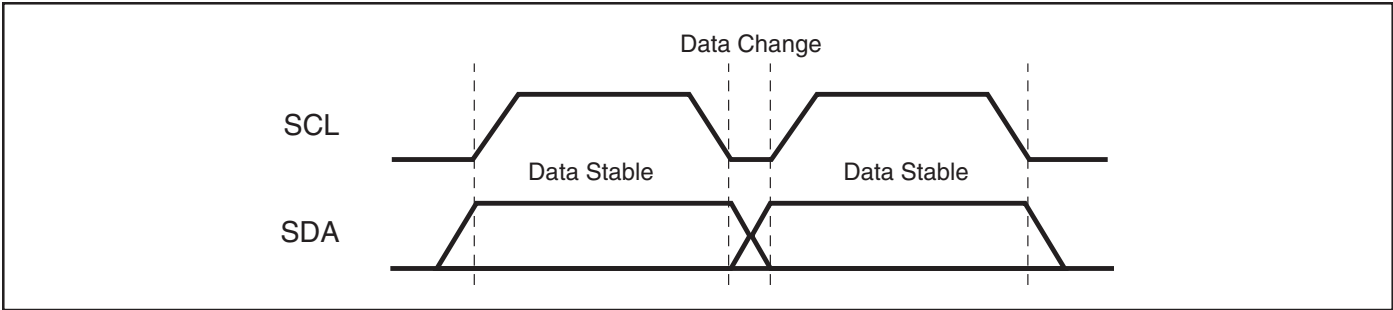

Figure 5. Command Configuration

Pin Connection ¹			Slave Device Address									
A2	A1	A0	BIT	7	6	5	4	3	2	1	0	
A2	A1	A0		1	0	1	0	A2	A1	A0	R/W	Normal Instruction ²
A2	A1	A0		0	1	1	0	A2	A1	A0	R/W	Permanent Write Protection Instruction ²
GND	GND	V _{HV}		0	1	1	0	0	0	1	0	Set Write Protection (SWP)
GND	V _{CC}	V _{HV}		0	1	1	0	0	1	1	0	Clear Write Protection (CWP)
GND	GND	V _{HV}		0	1	1	0	0	0	1	1	Read SWP
GND	V _{CC}	V _{HV}		0	1	1	0	0	1	1	1	Read CWP

Note:

- A2-A0 input pin connections must be GND (or floating), V_{CC}, or V_{HV}.
- Bits 1, 2, and 3 of the device address will be compared with the values on the external pins.

Figure 6. Byte Write

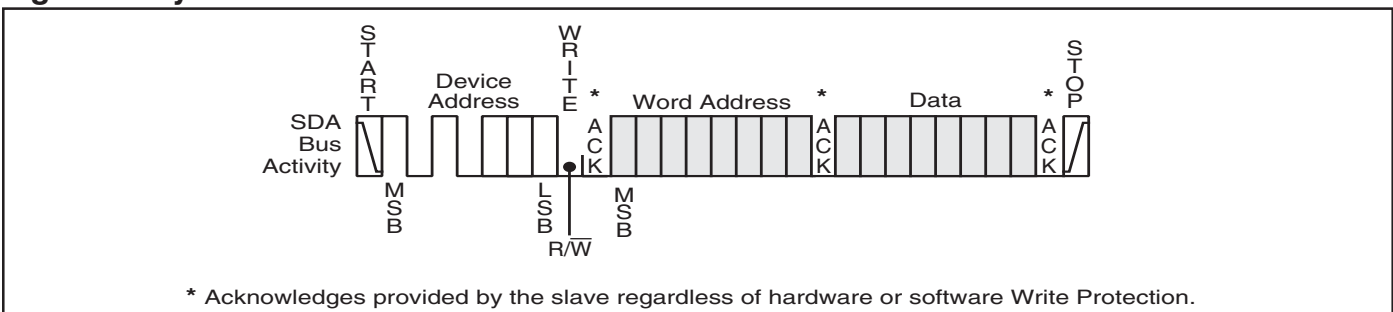

Figure 7. Page Write

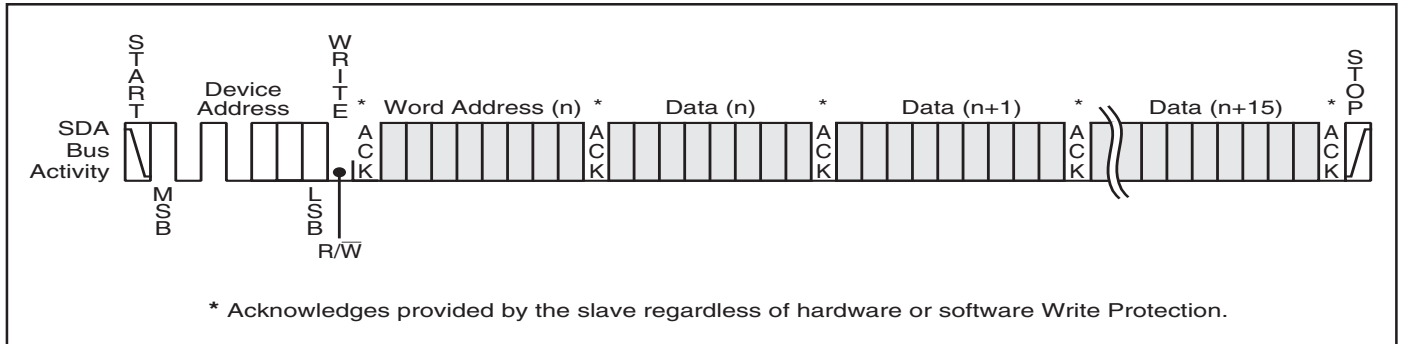

Figure 8. Current Address Read

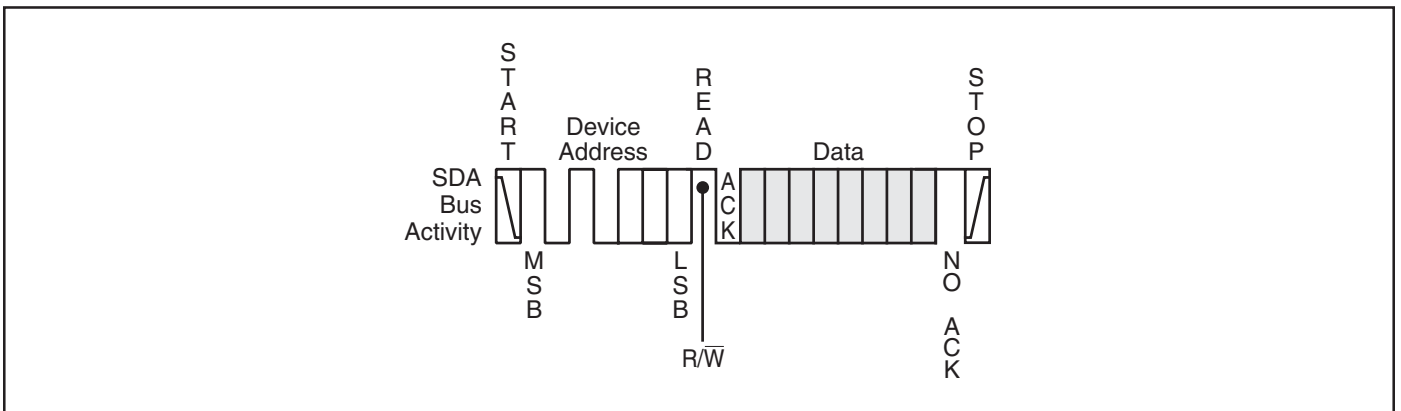

Figure 9. Random Address Read

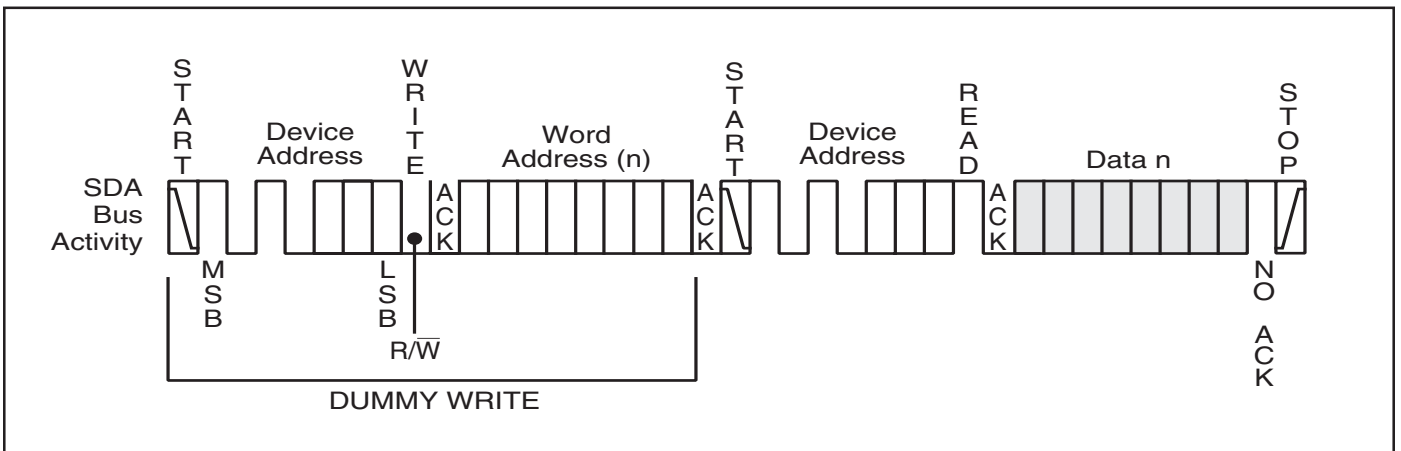

Figure 10. Sequential Read

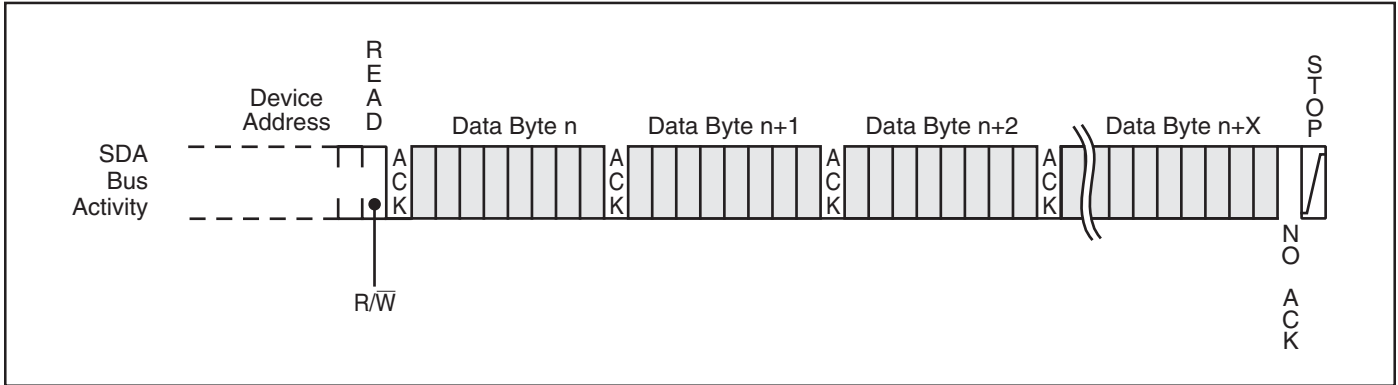

Figure 11. SET PERMANENT WRITE PROTECTION

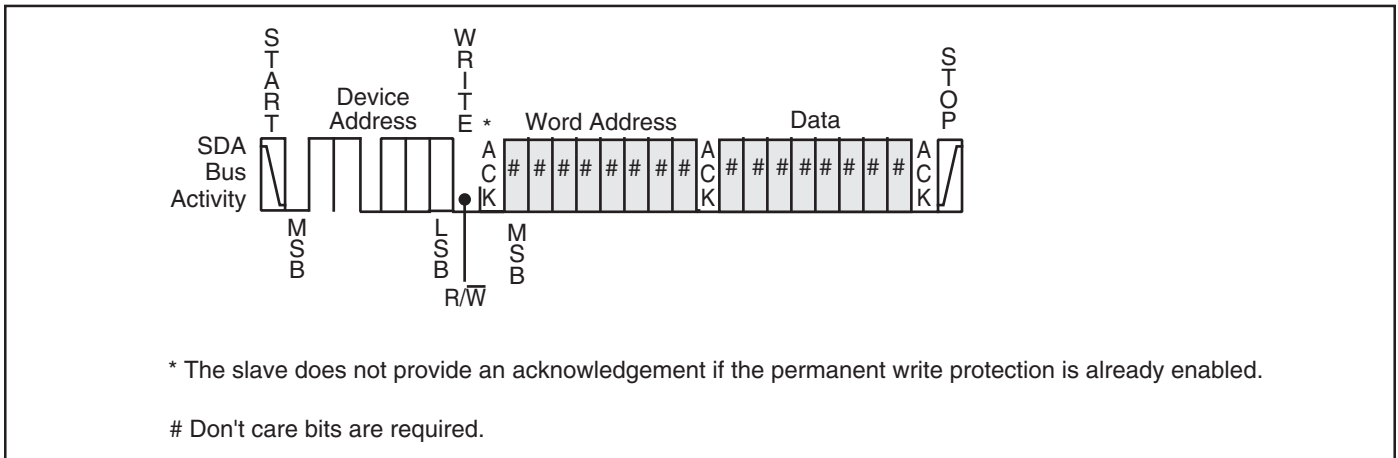
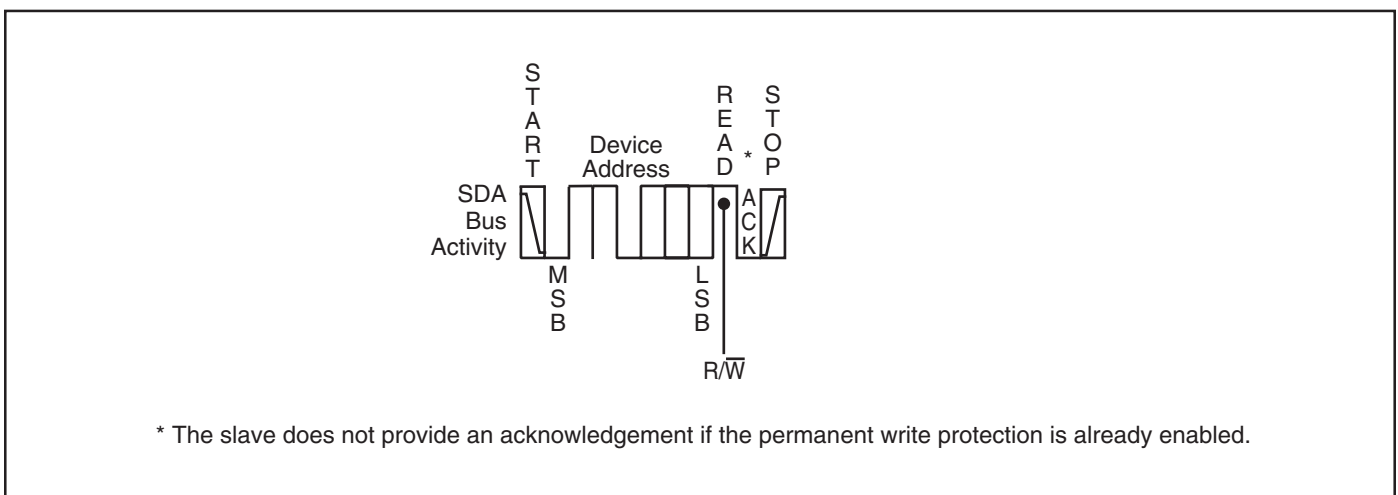

Figure 12. READ PERMANENT WRITE PROTECTION



IS34C02B

ABSOLUTE MAXIMUM RATINGS⁽¹⁾

Symbol	Parameter	Value	Unit
V _S	Supply Voltage	-0.5 to +6.5	V
V _P	Voltage on Any Pin	-0.5 to V _{CC} + 0.5	V
T _{BIAS}	Temperature Under Bias	-55 to +125	°C
T _{STG}	Storage Temperature	-65 to +150	°C
I _{OUT}	Output Current	5	mA

Notes:

1. Stress greater than those listed under ABSOLUTE MAXIMUM RATINGS may cause permanent damage to the device. This is a stress rating only and functional operation of the device at these or any other conditions above those indicated in the operational sections of this specification is not implied. Exposure to absolute maximum rating conditions for extended periods may affect reliability.

OPERATING RANGE

(IS34C02B-2)

Range	Ambient Temperature	V _{CC}
Industrial	-40°C to +85°C	1.7V to 3.6V

CAPACITANCE^(1,2)

Symbol	Parameter	Conditions	Max.	Unit
C _{IN}	Input Capacitance	V _{IN} = 0V	6	pF
C _{OUT}	Output Capacitance	V _{OUT} = 0V	8	pF

Notes:

1. Tested initially and after any design or process changes that may affect these parameters.
2. Test conditions: T_A = 25°C, f = 400 KHz, V_{CC} = 3.0V.

DC ELECTRICAL CHARACTERISTICSIndustrial (T_A = -40°C to +85°C)

Symbol	Parameter	Test Conditions	Min.	Max.	Unit
V _{OL1}	Output Low Voltage	V _{CC} = 1.7V, I _{OL} = 0.15 mA	—	0.2	V
V _{OL2}	Output Low Voltage	V _{CC} = 3.6V, I _{OL} = 2.1 mA	—	0.4	V
V _{IH}	Input High Voltage		V _{CC} x 0.7	V _{CC} + 0.5	V
V _{IL}	Input Low Voltage		-1.0	V _{CC} x 0.3	V
V _{HV}	A0 High Voltage	V _{HV} - V _{CC} ≥ 4.8V	7	10	V
I _{LI}	Input Leakage Current	V _{IN} = V _{CC} max.	—	3	μA
I _{LO}	Output Leakage Current		—	3	μA

Notes: V_{IL} min and V_{IH} max are reference only and are not tested.

POWER SUPPLY CHARACTERISTICSIndustrial (T_A = -40°C to +85°C)

Symbol	Parameter	Test Conditions	Min.	Max.	Unit
I _{CC1}	V _{CC} Operating Current	Read at 100 KHz (V _{CC} = 3.6V)	—	1.0	mA
I _{CC2}	V _{CC} Operating Current	Write at 100 KHz (V _{CC} = 3.6V)	—	3.0	mA
I _{SB1}	Standby Current	V _{CC} = 1.7V	—	1	μA
I _{SB2}	Standby Current	V _{CC} = 3.6V	—	2	μA

AC ELECTRICAL CHARACTERISTICSIndustrial (T_A = -40°C to +85°C)

Symbol	Parameter	1.7V ≤ V _{CC} < 2.2V		2.2V ≤ V _{CC} ≤ 3.6V		Unit
		Min.	Max.	Min.	Max.	
f _{SCL}	SCL Clock Frequency	0	100	0	400	KHz
T	Noise Suppression Time ⁽¹⁾	—	100	—	50	ns
t _{Low}	Clock Low Period	4.7	—	1.2	—	μs
t _{High}	Clock High Period	4	—	0.6	—	μs
t _{BUF}	Bus Free Time Before New Transmission ⁽¹⁾	4.7	—	1.2	—	μs
t _{SU:STA}	Start Condition Setup Time	4	—	0.6	—	μs
t _{SU:STO}	Stop Condition Setup Time	4	—	0.6	—	μs
t _{HD:STA}	Start Condition Hold Time	4	—	0.6	—	μs
t _{HD:STO}	Stop Condition Hold Time	4	—	0.6	—	μs
t _{SU:DAT}	Data In Setup Time	100	—	100	—	ns
t _{HD:DAT}	Data In Hold Time	0	—	0	—	ns
t _{SU:WP}	WP pin Setup Time	4	—	0.6	—	μs
t _{HD:WP}	WP pin Hold Time	4.7	—	1.2	—	μs
t _{DH}	Data Out Hold Time (SCL Low to SDA Data Out Change)	100	—	50	—	ns
t _{AA}	Clock to Output (SCL Low to SDA Data Out Valid)	100	3500	50	900	ns
t _R	SCL and SDA Rise Time ⁽¹⁾	—	1000	—	300	ns
t _F	SCL and SDA Fall Time ⁽¹⁾	—	300	—	300	ns
t _{WR}	Write Cycle Time	—	5	—	5	ms

Note:

1. These parameters are characterized, but not 100% tested.

FIGURE 13. AC WAVEFORMS

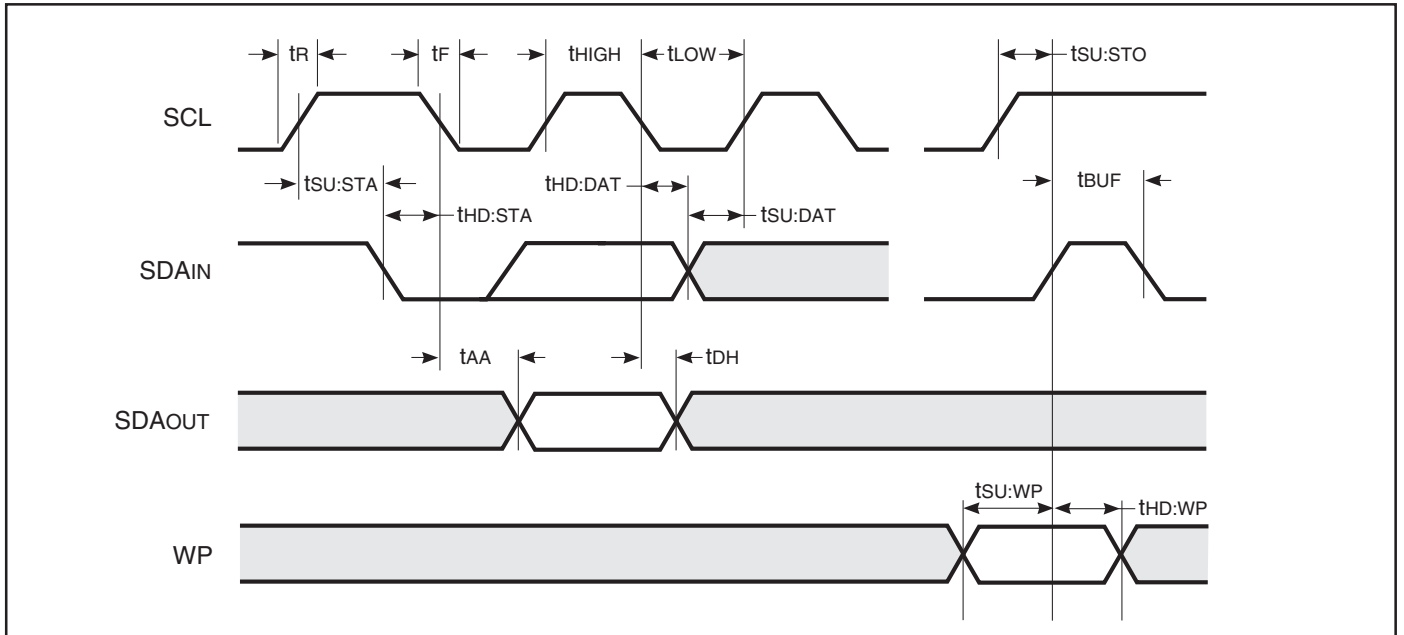
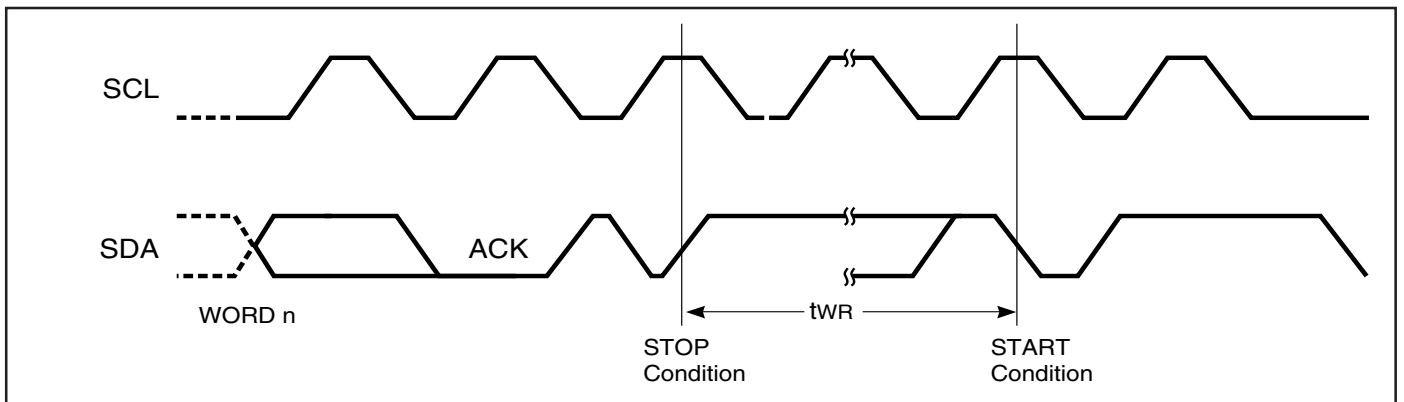

FIGURE 14. WRITE CYCLE TIMING



ORDERING INFORMATION**Industrial Range: -40°C to +85°C, Lead-free**

Voltage Range	Part Number	Package
1.7V	IS34C02B-2DLI	DFN
to 3.6V	IS34C02B-2ZLI	TSSOP

PACKAGING INFORMATION

Dual Flat No-Lead
Package Code: D (8-pad)

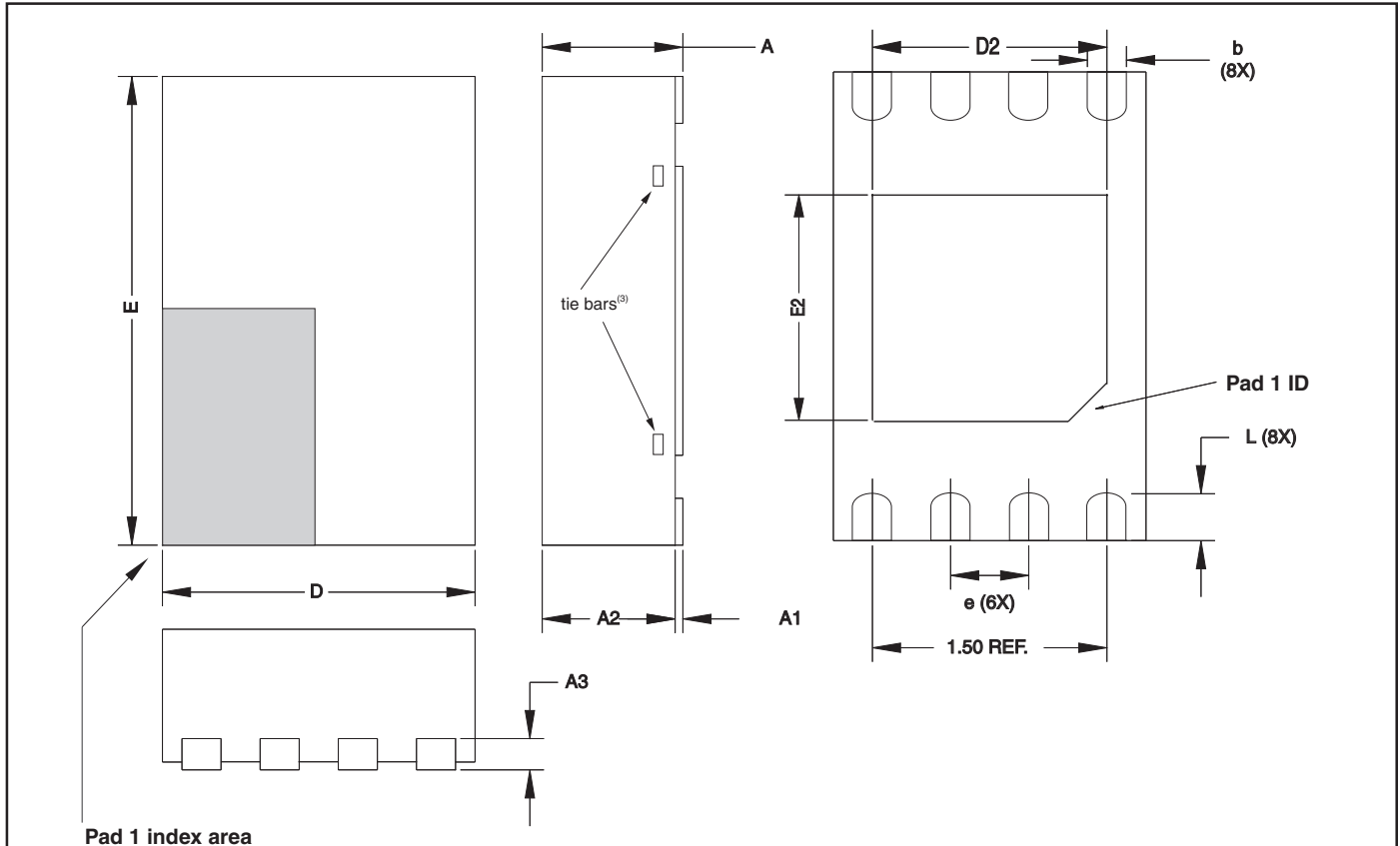

DFN

MILLIMETERS

Sym.	Min.	Nom.	Max.
N0. Pad		8	
D		2.00 BSC	
E		3.00 BSC	
D2	1.50	—	1.75
E2	1.60	—	1.90
A	0.70	0.75	0.80
A1	0.0	0.02	0.05
A2	—	—	0.75
A3		0.20 REF	
L	0.30	0.40	0.50
e		0.50 BSC	
b	0.18	0.25	0.30

Notes:

1. Refer to JEDEC Drawing MO-229.
2. This is the metallized terminal and is measured between 0.18 mm and 0.30 mm from the terminal tip. The terminal may have a straight end instead of rounded.
3. Package may have exposed tie bars, ending flush with package edge.

PACKAGING INFORMATION



Thin Shrink Small Outline TSSOP

Package Code: Z (8 pin, 14 pin)

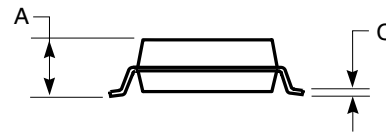
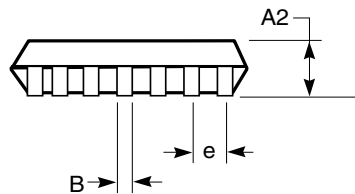
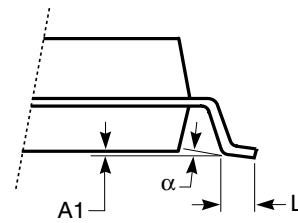
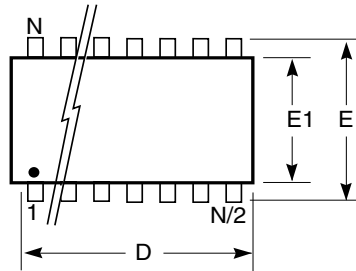

TSSOP (Z)				
Ref. Std.	JEDEC MO-153			
No. Leads	8			
Symbol	Millimeters		Inches	
	Min	Max	Min	Max
A	—	1.20	—	0.047
A1	0.05	0.15	0.002	0.006
A2	0.80	1.05	0.032	0.041
B	0.19	0.30	0.007	0.012
C	0.09	0.20	0.004	0.008
D	2.90	3.10	0.114	0.122
E1	4.30	4.50	0.169	0.177
E	6.40 BSC		0.252 BSC	
e	0.65 BSC		0.026 BSC	
L	0.45	0.75	0.018	0.030
alpha	—	8°	—	8°

TSSOP (Z)				
Ref. Std.	JEDEC MO-153			
No. Leads	14			
Symbol	Millimeters		Inches	
	Min	Max	Min	Max
A	—	1.20	—	0.047
A1	0.05	0.15	0.002	0.006
A2	0.80	1.05	0.031	0.041
B	0.19	0.30	0.007	0.012
C	0.09	0.20	0.0035	0.008
D	4.90	5.10	0.193	0.201
E1	4.30	4.50	0.170	0.177
E	6.40 BSC		0.252 BSC	
e	0.65 BSC		0.026 BSC	
L	0.45	0.75	0.0177	0.0295
alpha	—	8°	—	8°

SSI reserves the right to make changes to its products at any time without notice in order to improve design and supply the best possible product. We assume no responsibility for any errors which may appear in this publication. © Copyright 2002, Integrated Silicon Solution, Inc.