

UPM-EA DC-DC Series Data Sheet

Programmable-Output, 45 Watts

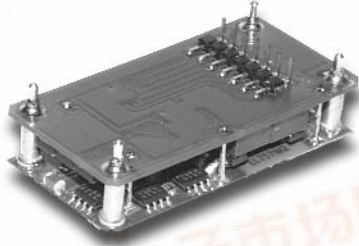

Features

- 5-bit programmable output
- High efficiency topology
- Excellent transient response
- Power Good signal
- Surface-mount construction
- Short-circuit protection
- Low profile
- Water washable

Description

The UPM-EA programmable DC-DC converter is a high efficiency, step-down converter. The UPM-EA incorporates a 5-bit DAC output voltage control which is compliant with standard VRM VID Protocol. The UPM-EA provides up to 45 watts of output power at 13A output current, and at output voltages from 1.30 to 3.50V. Featuring open-frame, 100% surface-mount construction and high efficiency topology, the UPM-EA excels in difficult thermal environments.

THE UPM-EA SERIES IS NOT FOR NEW DESIGNS.

Technical Specifications

Input	
Voltage Range	4.5 - 5.5 VDC
5 VDC Nominal	
Input Undervoltage Lockout, Power On	3.6 - 4.4 VDC
Input Undervoltage Lockout, Power Down	3.15 - 3.85 VDC
Startup Time	10 ms

Output	
Setpoint Accuracy	See Output Voltage Table
Line Regulation V_{in} Min. - V_{in} Max., I_{out} Rated	See Output Voltage Table
Load Regulation I_{out} Min. - I_{out} Max., V_{in} Nom.	See Output Voltage Table
Ripple and Noise, DC - 20 MHz ^{††}	50 mV Pk-Pk
Current Limit Protection Type	Hiccup
Current Limit Threshold Range, % of I_{out} Rated	130%
Short Circuit Protection Type	Hiccup
Power Good Signal Characteristics	
Asserts Logic "High" When V_{out} is Between Following Levels	
Lower Threshold, % V_{out} Programmed	-16% to -10%
Upper Threshold, % V_{out} Programmed	+10% to +16%

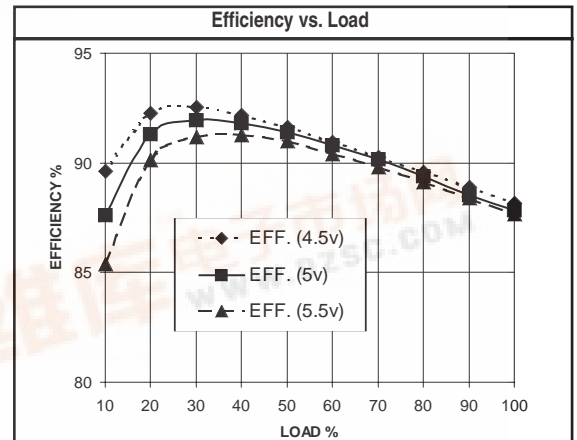

General	
Switching Frequency	200 kHz
Temperature Coefficient	50ppm/°C
Baseplate Operating Temperature	0 to +100°C
Storage Range	-40 to +100°C
Internal Input Capacitance	500 μ F Max.
Recommended External Capacitance	
Input	100 μ F/A I_{out}
Output	100 μ F/A I_{out}
MTBF [†] (Bellcore TR-NWT-000332)	2.9 x 10 ⁶ hrs
Safety	UL, CSA
Weight (approx.)	0.9 oz

Notes
[†] MTBF predictions may vary slightly from model to model.
^{††} When used with recommended capacitors
Specifications typically at 25°C, normal line, and full load, unless otherwise stated.
Soldering Conditions: I/O pins, 260°C, ten seconds; fully compatible with commercial wave-soldering equipment.
Safety: Agency approvals may vary from model to model. Please consult factory for specific model information.
Units are water-washable and fully compatible with commercial spray or immersion post wave-solder washing equipment.



UPM-EA DC-DC Series Data Sheet

Programmable-Output, 45 Watts

P4	P3	P2	P1	P0	OUTPUT VOLTAGE	TOTAL ERROR BAND
1	1	1	1	1	0.00	±24 mV
0	1	1	1	1	1.30	±24 mV
0	1	1	1	0	1.35	±24 mV
0	1	1	0	1	1.40	±24 mV
0	1	1	0	0	1.45	±24 mV
0	1	0	1	1	1.50	±24 mV
0	1	0	1	0	1.55	±24 mV
0	1	0	0	1	1.60	±24 mV
0	1	0	0	0	1.65	±24 mV
0	0	1	1	1	1.70	±24 mV
0	0	1	1	0	1.75	±24 mV
0	0	1	0	1	1.80	±24 mV
0	0	1	0	0	1.85	±24 mV
0	0	0	1	1	1.90	±24 mV
0	0	0	1	0	1.95	±24 mV
0	0	0	0	1	2.00	±24 mV
0	0	0	0	0	2.05	±24 mV
1	1	1	1	0	2.10	±24 mV
1	1	1	0	1	2.20	±24 mV
1	1	1	0	0	2.30	±24 mV
1	1	0	1	1	2.40	±24 mV
1	1	0	1	0	2.50	±25 mV
1	1	0	0	1	2.60	±26 mV
1	1	0	0	0	2.70	±27 mV
1	0	1	1	1	2.80	±28 mV
1	0	1	1	0	2.90	±29 mV
1	0	1	0	1	3.00	±30 mV
1	0	1	0	0	3.10	±31 mV
1	0	0	1	1	3.20	±32 mV
1	0	0	1	0	3.30	±33 mV
1	0	0	0	1	3.40	±34 mV
1	0	0	0	0	3.50	±40 mV

NOTE: Logic "0" < 1.5V; Logic "1" > (Vin - 1.5V).
Total Error Band includes initial setpoint accuracy, line, and load regulation.

**THE UPM-EA SERIES IS NOT
FOR NEW DESIGNS.**

Mechanical Drawing

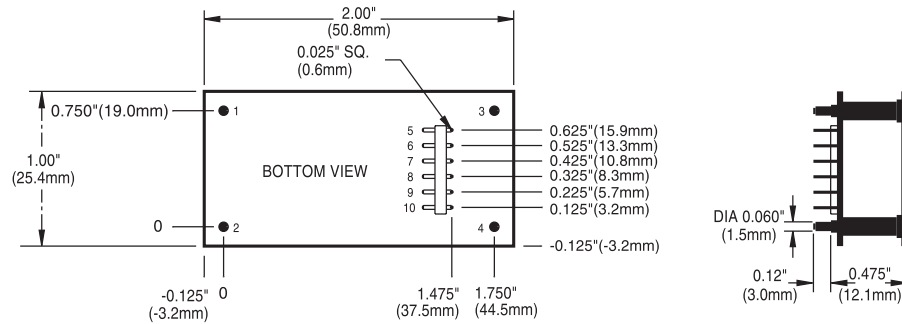

Thermal Impedance	
Natural Convection	9.4 °C/W
100 LFM	6.6 °C/W
200 LFM	4.3 °C/W
300 LFM	3.2 °C/W
400 LFM	2.7 °C/W
Note: Thermal impedance data is dependent on many environmental factors. The exact thermal performance should be validated for specific application.	

Pin	Function
1	-V _{in}
2	+V _{in}
3	-V _{out}
4	+V _{out}
5	P4
6	P3
7	P2
8	P1
9	P0
10	Ground
11	Power Ground

Tolerances	
Inches:	(Millimeters)
.XX ± 0.020	.X ± 0.5
.XXX ± 0.010	.XX ± 0.25
Pin:	
± 0.002	± 0.05
(Dimensions as listed unless otherwise specified.)	

THE UPM-EA SERIES IS NOT FOR NEW DESIGNS.

This page is offered as a reference. Consult factory for actual availability of options. When ordering equipment options, use the following suffix information. Select preferred option(s) and add the suffix to the model number. Ordering option examples are located below the options table.

OPTION	SUFFIX	APPLICABLE SERIES	REMARKS
Negative Logic	N	HAS, HBD, HBS, HES, HLS, HLD, LES, QBS, QES, QLS, TES, TQD	TTL "Low" Turns Module ON TTL "High" Turns Module OFF
Lucent-Compatible Trim	T	HAS, HBD, HBS, HES, HLS, QBS, QES, QLS	
Trim	1	IAS, LES	
Enable	2	IAD, IAS, LES, SMS	
Trim and Enable	3	IAS, LES	
Pin Length and Heat Sink Options			Standard Pin Length is 0.180" (4.6mm)
0.110" (2.8mm) Pin Length	8	All Leaded Models	
0.150" (3.8mm) Pin Length	9	All Leaded Models	
0.24" (6.1mm) Horizontal Heat Sink	1H	All 1/4-Bricks, 1/2-Bricks, 3/4-Bricks, Full-Bricks (Except HLS, HLD, QLS, TLD, and TKD Packages)	Includes Thermal Pad
0.24" (6.1mm) Vertical Heat Sink	1V	All 1/4-Bricks, 1/2-Bricks, 3/4-Bricks, Full-Bricks (Except HLS, HLD, QLS, TLD, and TKD Packages)	Includes Thermal Pad
0.45" (11.4mm) Horizontal Heat Sink	2H	All 1/4-Bricks, 1/2-Bricks, 3/4-Bricks, Full-Bricks (Except HLS, HLD, QLS, TLD, and TKD Packages)	Includes Thermal Pad
0.45" (11.4mm) Vertical Heat Sink	2V	All 1/4-Bricks, 1/2-Bricks, 3/4-Bricks, Full-Bricks (Except HLS, HLD, QLS, TLD, and TKD Packages)	Includes Thermal Pad
0.95" (24.1mm) Horizontal Heat Sink	3H	All 1/4-Bricks, 1/2-Bricks, 3/4-Bricks, Full-Bricks (Except HLS, HLD, QLS, TLD, and TKD Packages)	Includes Thermal Pad
0.95" (24.1mm) Vertical Heat Sink	3V	All 1/4-Bricks, 1/2-Bricks, 3/4-Bricks, Full-Bricks (Except HLS, HLD, QLS, TLD, and TKD Packages)	Includes Thermal Pad

Example Options:

HBS050ZG-ANT3V = HBS050ZG-A with negative logic, Lucent-compatible trim, and 0.95" vertical heat sink.

LES015YJ-3N = LES015YJ with optional trim and enable, negative logic.

QBS066ZG-AT8 = QBS066ZG-A with Lucent-compatible trim and 0.110" pin length.

NUCLEAR AND MEDICAL APPLICATIONS - Power-One products are not authorized for use as critical components in life support systems, equipment used in hazardous environments, or nuclear control systems without the express written consent of the respective divisional president of Power-One, Inc.

TECHNICAL REVISIONS - The appearance of products, including safety agency certifications pictured on labels, may change depending on the date manufactured. Specifications are subject to change without notice.