



# V-INFINITY

## VHB100W-Q24-S12 DC-DC Converter

Rev. 11-2007

### Features

- 100W isolated output
- Efficiency of 82%
- 350KHz switching frequency
- 4:1 input range
- Regulated output
- Continuous short circuit protection
- Five-sided metal case
- Industry standard half-brick package



Model Number	Input Voltage	Output Voltage	Output Current	Ripple and Noise		Efficiency
				mV-RMS	mVp-p	
VHB100W-Q24-S12	9-36VDC	12VDC	8.3A	60mV	150mV	82%

### Input

Input Voltage Range	24V	9-36V
Positive Logic Remote ON/OFF	Logic Compatibility: Open Collector reference to -Vin Module ON: Open Circuit Module OFF: < 0.8VDC	
Input Filter	PI Type	

### Output

Voltage Accuracy	±1% max.
Transient Response: 25% Step Load Change	<500µ sec.
External Trim Adj. Range	±10%
Ripple & Noise	20MHz BW 60mV RMS max. 150mVp-p max.
Short Circuit Protection	Continuous
Line Regulation <sup>1</sup>	±0.2% max
Load Regulation <sup>2</sup>	±0.2% max
Over Voltage Protection trip Range, % Vo nom.	115-140%
Current Limit	110-140% Nominal Output

### General Specifications

Efficiency	82%
Switching Frequency	350KHz, Typ.
Operating Case Temperature	-40°C to 100°C
Storage Temperature	-40°C to 105°C
Thermal Shutdown, Case Temp.	100°C Typ.
Dimensions	2.28x2.40x0.50 inches 57.9x61.0x12.7mm
Case Material	aluminum baseplate w/ plastic case

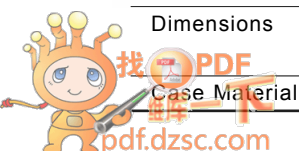

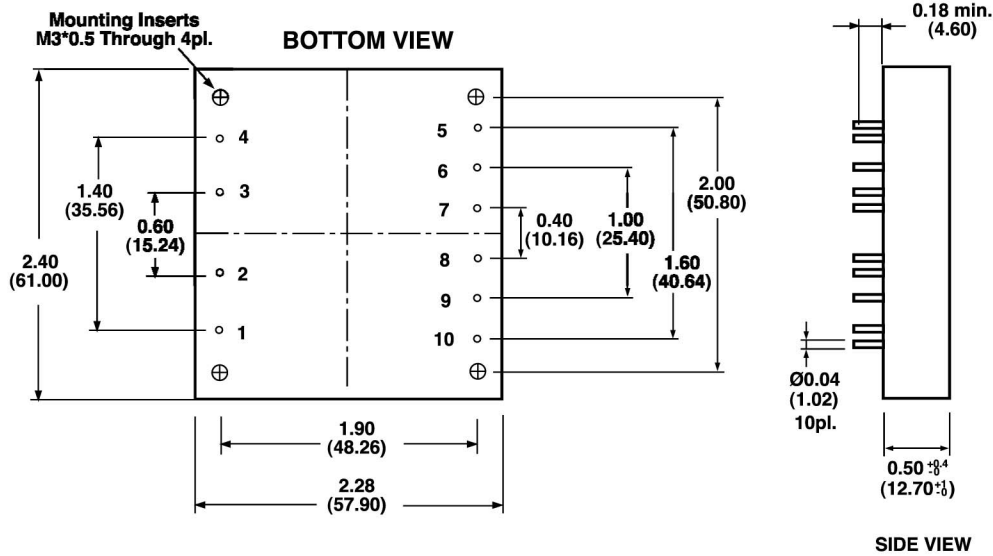

Pin	Function
1	+Vin
2	On/Off
3	CASE
4	-Vin
5	-Vout
6	-Sense
7	Trim
8	+Sense
9	+Vout

## Application Notes

Derating:

The operating case temperature range of the VHB100W series is -40°C to +100°C. When operating the VHB100W, proper derating or cooling is needed. Following is the derating curve of VHB100W without heat sink.

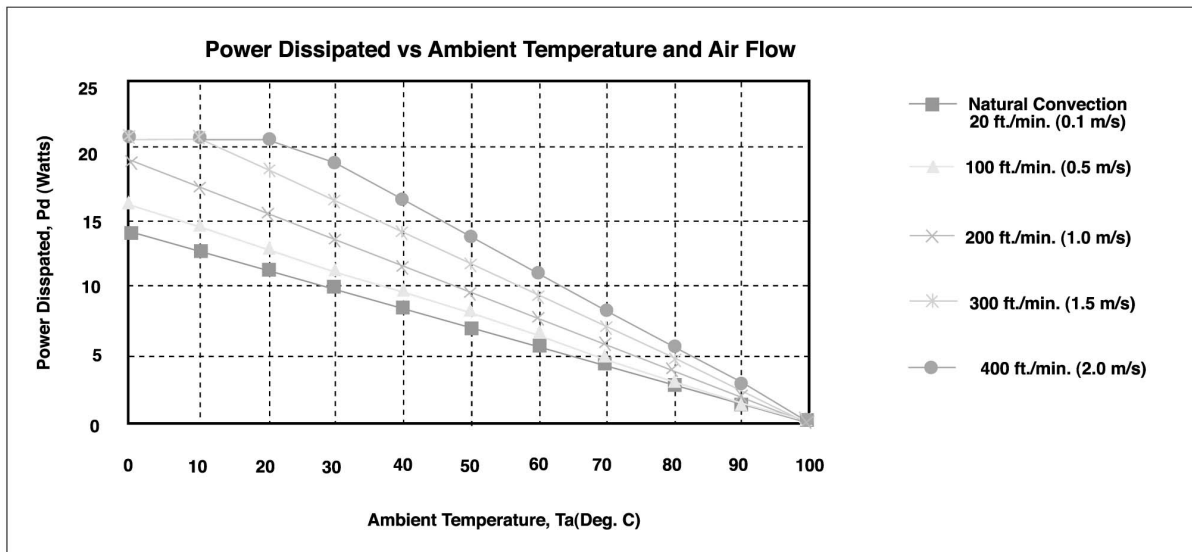

Forced Convection Power Derating without Heat Sink

Where:

The power dissipation (Pd) is

$$Pd = P_i - P_o = P_o (1 - \eta) / \eta$$

The thermal resistances are listed below.

AIR FLOW RATE	TYPICAL Rca
Natural Convection 20 ft./min. (0.1 m/s)	7.12 °C/W
100 ft./min.	6.21 °C/W
200 ft./min.	5.17 °C/W
300 ft./min.	4.29 °C/W
400 ft./min.	3.64 °C/W

The temperature rise (ΔT):

$$\Delta T = Pd * Rca$$

## Remote On/Off Control

The VHB100W series allows the user to switch the module on and off electronically with the remote on/off feature. Logic control defaults to "positive" logic. The diagram shows the recommended circuits for positive logic. The "negative logic" option is also available.

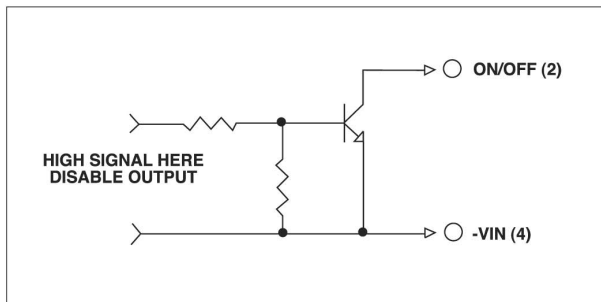
**Logic Table**

Logic State (PIN 2)	Negative Logic	Positive Logic
Logic Low - Switch Closed	Module on	Module off
Logic High - Switch Open	Module off	Module on

## External Output Trimming

Output may optionally be trimmed ( $\pm 10\%$ ) with external fixed resistors or an external trimpot as shown.

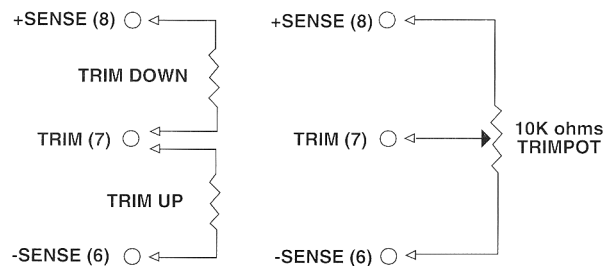

## Output Noise

The output noise is measured with a 10uF tantalum capacitor and a 1.0uF ceramic capacitor across the output.

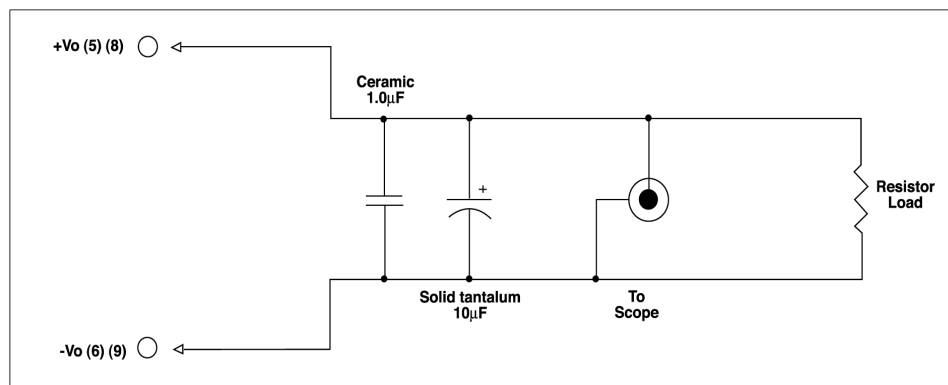

Output Noise Test Circuit schematic