

# VRE202

## Precision Surface Mount Reference Supplies



THALER CORPORATION • 2015 N. FORBES BOULEVARD • TUCSON, AZ. 85745 • (520) 882-4000

### FEATURES

- **VERY HIGH ACCURACY:** 2.5000 V OUTPUT  $\pm 200 \mu\text{V}$
- **EXTREMELY LOW DRIFT:** 0.6 ppm/ $^{\circ}\text{C}$   $55^{\circ}\text{C}$  to  $+125^{\circ}\text{C}$
- **LOW WARM-UP DRIFT:** 1 ppm Typ.
- **EXCELLENT STABILITY:** 6 ppm/1000 Hrs. Typ.
- **EXCELLENT LINE REGULATION:** 6ppm/V Typ.
- **HERMETIC 20 TERMINAL CERAMIC LCC**
- **MILITARY PROCESSING OPTION**

### APPLICATIONS

- **PRECISION A/D and D/A CONVERTERS**
- **TRANSDUCER EXCITATION**
- **ACCURATE COMPARATOR THRESHOLD REFERENCE**
- **HIGH RESOLUTION SERVO SYSTEMS**
- **DIGITAL VOLTMETERS**
- **HIGH PRECISION TEST and MEASUREMENT INSTRUMENTS**

### DESCRIPTION

VRE202 Series Precision Voltage References provide ultrastable +2.5000V outputs with  $\pm 200 \mu\text{V}$  initial accuracy and temperature coefficient as low as 0.6 ppm/ $^{\circ}\text{C}$  over the full military temperature range. This improvement in accuracy is made possible by a unique, proprietary multipoint laser compensation technique developed by Thaler Corporation. Significant improvements have been made in other performance parameters as well, including initial accuracy, warm-up drift, line regulation, and long-term stability, making the VRE202 series the most accurate and stable 2.5V surface mount references available.

VRE202 devices are available in two operating temperature ranges,  $-25^{\circ}\text{C}$  to  $+85^{\circ}\text{C}$  and  $-55^{\circ}\text{C}$  to  $+125^{\circ}\text{C}$ , and two electrical performance grades. All devices are packaged in 20 terminal ceramic LCC packages for maximum long-term stability.

"M" versions are screened for high reliability and quality.

### SELECTION GUIDE

Type	Output	Temperature Operating Range	Max. Volt Deviation
VRE202C	+2.5V	$-25^{\circ}\text{C}$ to $+85^{\circ}\text{C}$	200 $\mu\text{V}$
VRE202CA	+2.5V	$-25^{\circ}\text{C}$ to $+85^{\circ}\text{C}$	100 $\mu\text{V}$
VRE202M	+2.5V	$-55^{\circ}\text{C}$ to $+125^{\circ}\text{C}$	400 $\mu\text{V}$
VRE202MA	+2.5V	$-55^{\circ}\text{C}$ to $+125^{\circ}\text{C}$	200 $\mu\text{V}$



# ELECTRICAL SPECIFICATIONS

# VRE202

Vps = ±15V, T = 25°C, RL = 10k $\Omega$  unless otherwise noted.

MODEL	C			CA			M			MA			
PARAMETERS	MIN	TYP	MAX	MIN	TYP	MAX	MIN	TYP	MAX	MIN	TYP	MAX	UNITS
<b>ABSOLUTE MAXIMUM RATINGS</b>													
Power Supply	+13.5		+22	*		*	*		*	*		*	V
Operating Temperature	-25		85	*		*	-55		125	-55		125	°C
Storage Temperature	-65		150	*		*	*		*	*		*	°C
Short Circuit Protection	Continuous				*			*			*		
<b>OUTPUT VOLTAGE</b>													
VRE202		+2.5			*			*			*		V
<b>OUTPUT VOLTAGE ERRORS</b>													
Initial Error			300			200			300			200	$\mu$ V
Warmup Drift		2			1			2			1		ppm
$T_{min} - T_{max}$ (1)			200			100			400			200	$\mu$ V
Long-Term Stability		6			*			*			*		ppm/1000hrs
Noise (.1-10Hz)		1.5			*			*			*		$\mu$ Vpp
<b>OUTPUT CURRENT</b>													
Range	±10			*			*			*			mA
<b>REGULATION</b>													
Line		6	10		*	*		*	*		*	*	ppm/V
Load		3			*			*			*		ppm/mA
<b>OUTPUT ADJUSTMENT</b>													
Range		10			*			*			*		mV
Temperature Coeff.		4			*			*			*		$\mu$ V/°C/mV
<b>POWER SUPPLY CURRENTS</b> (2)													
VRE202 +PS		5	7		*	*		*	*		*	*	mA
VRE202 -PS		5	7		*	*		*	*		*	*	mA

NOTES: \*Same as C Models.

1. Using the box method, the specified value is the maximum deviation from the output voltage at 25°C over the specified operating temperature range.

2. The specified values are unloaded.

# TYPICAL PERFORMANCE CURVES

**V<sub>OUT</sub> vs. TEMPERATURE**

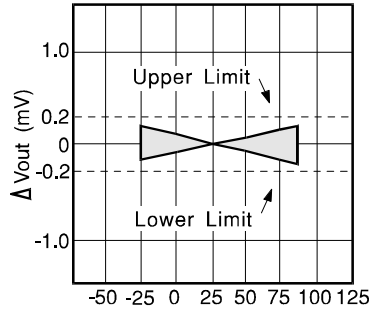

**Temperature °C  
VRE202C**

**V<sub>OUT</sub> vs. TEMPERATURE**

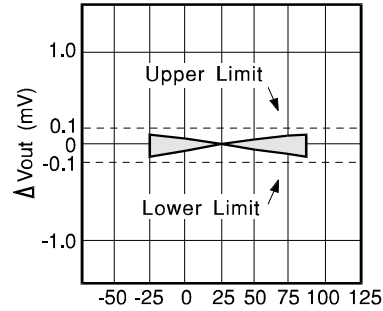

**Temperature °C  
VRE202CA**

**V<sub>OUT</sub> vs. TEMPERATURE**

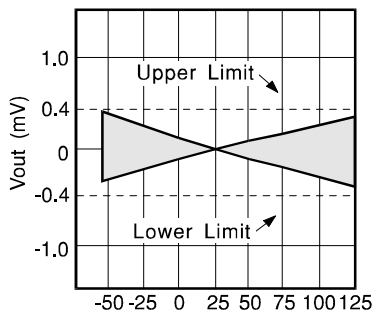

**Temperature °C  
VRE202M**

**V<sub>OUT</sub> vs. TEMPERATURE**

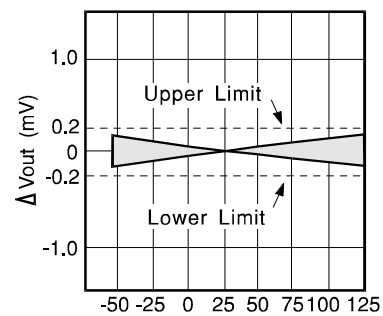

**Temperature °C  
VRE202MA**

**QUIESCENT CURRENT vs. TEMP**

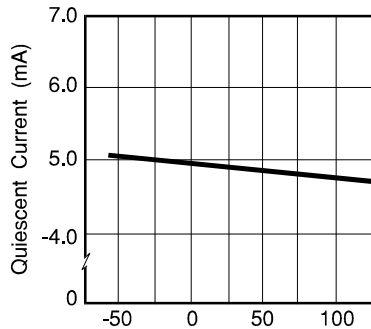

**Temperature °C**

**JUNCTION TEMP. RISE vs. OUTPUT CURRENT**

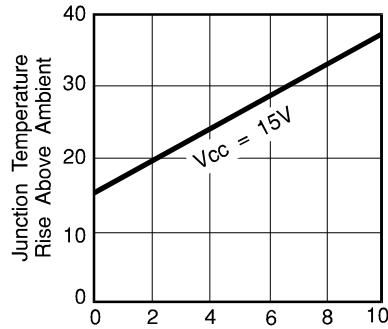

**Output Current (mA)**

**PSRR vs. FREQUENCY**

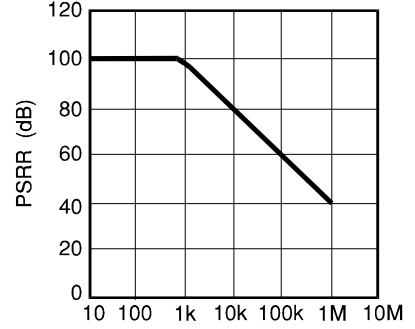

**Frequency (Hz)**

## DISCUSSION OF PERFORMANCE

### THEORY OF OPERATION

The following discussion refers to the schematic below. A FET current source is used to bias a 6.3 zener diode. The zener voltage is divided by the resistor network R1 and R2. This voltage is then applied to the noninverting input of the operational amplifier which amplifies the voltage to produce a 2.5000V output. The gain is determined by the resistor networks R3 and R4:  $G=1 + R4/R3$ . The 6.3 zener diode is used because it is the most stable diode over time and temperature.

The current source provides a closely regulated zener current, which determines the slope of the references' voltage vs. temperature function. By trimming the zener current a lower drift over temperature can be achieved. But since the voltage vs. temperature function is nonlinear this compensation technique is not well suited for wide temperature ranges.

Thaler Corporation has developed a nonlinear compensation network of thermistors and resistors that is used in the VRE series voltage references. This proprietary network eliminates most of the nonlinearity in the voltage vs. temperature function. By then adjusting the slope, Thaler Corporation produces a very stable voltage over wide temperature ranges. This network is less than 2% of the overall network resistance so it has a negligible effect on long term stability. By using highly stable resistors in our network, we produce a voltage reference that also has very good long term stability.

### APPLICATION INFORMATION

Figure 2 shows the proper connection of the VRE202 series voltage references with the optional trim resistors. Pay careful attention to the circuit layout to avoid noise pickup and voltage drops in the lines.

The VRE202 series voltage references have the ground terminal brought out on two pins (pin 9 and pin 10) which are connected together internally. This allows the user to achieve greater accuracy when using a socket. Voltage references have a voltage drop across their power supply ground pin due to quiescent current flowing through the contact resistance. If the contact resistance was constant with time and temperature, this voltage drop could be trimmed out. When the reference is plugged into a socket, this source of error can be as high as 20ppm. By connecting pin 10 to the power supply ground and pin 9 to a high impedance ground point in the measurement circuit, the error due to the contact resistance can be eliminated. If the unit is soldered into place, the contact resistance is sufficiently small that it does not effect performance.

### VRE202

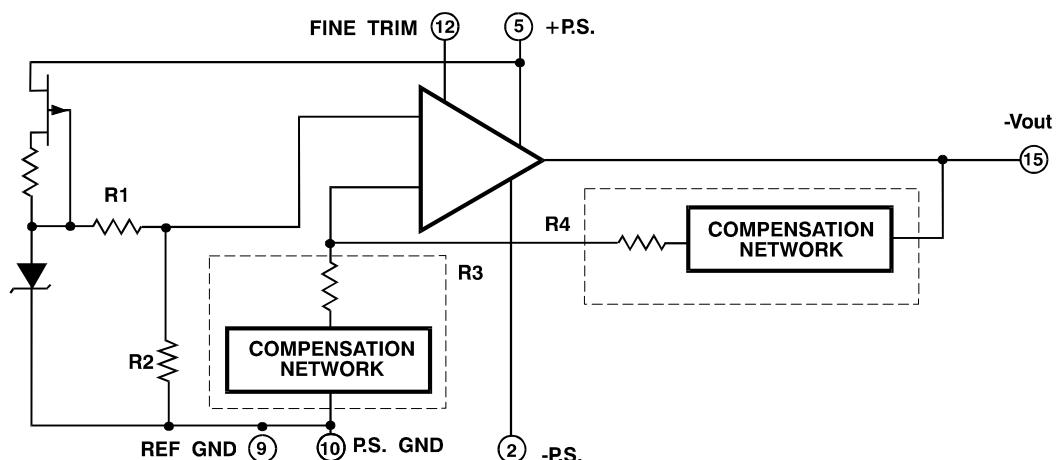

FIGURE 1

## EXTERNAL CONNECTIONS

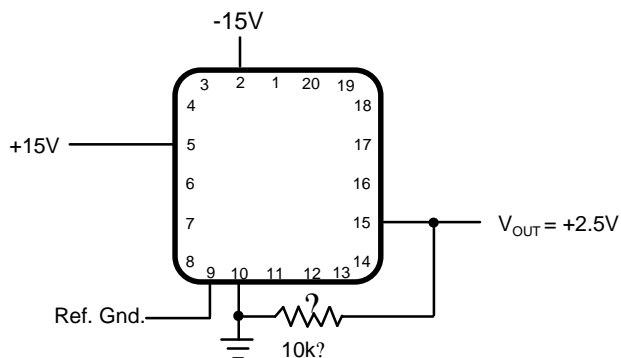
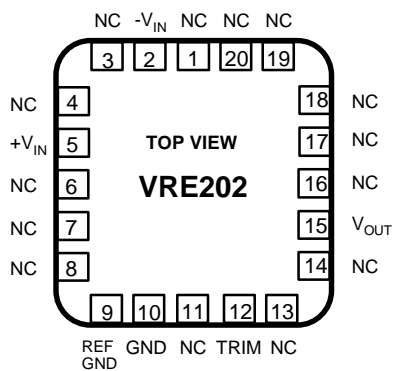
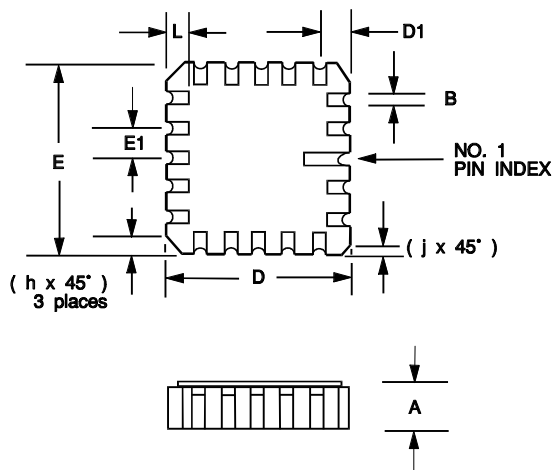

FIGURE 2

## PIN CONFIGURATION



## MECHANICAL



DIM	INCHES		MILLIMETER	
	MIN	MAX	MIN	MAX
A	0.090	0.110	2.29	2.79
B	0.022	0.028	0.56	0.71
D	0.342	0.358	8.68	9.09
D1	0.048	0.052	1.22	1.32
E	0.342	0.358	8.68	9.09
E1	0.045	0.055	1.114	1.40
j	0.010 REF		.254 REF	
h	0.040 REF		1.02 REF	
L	0.045	0.055	1.14	1.40



# VRE204

## Precision Surface Mount Reference Supply

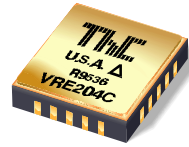

THALER CORPORATION • 2015 N. FORBES BOULEVARD • TUCSON, AZ. 85745 • (520) 882-4000

### FEATURES

- **VERY HIGH ACCURACY:** 4.5000 V OUTPUT  $\pm 0.4$  mV
- **EXTREMELY LOW DRIFT:** 0.6 ppm/ $^{\circ}$ C -55 $^{\circ}$ C to +125 $^{\circ}$ C
- **EXCELLENT STABILITY:** 6ppm/1000 Hrs. Typ.
- **EXCELLENT LINE REGULATION:** 6 ppm/V Typ.
- **WIDE SUPPLY RANGE:** +13.5 V to +22.0 V
- **HERMETIC 20 TERMINAL CERAMIC LCC**
- **MILITARY PROCESSING AVAILABLE**

### APPLICATIONS

- **PRECISION A/D and D/A CONVERTERS**
- **TRANSDUCER EXCITATION**
- **ACCURATE COMPARATOR THRESHOLD REFERENCE**
- **HIGH RESOLUTION SERVO SYSTEMS**
- **DIGITAL VOLTMETERS**
- **HIGH PRECISION TEST and MEASUREMENT INSTRUMENTS**

### DESCRIPTION

VRE204 Series Precision Voltage References provide ultrastable +4.500 V outputs with up to  $\pm 0.4$  mV initial accuracy and temperature coefficient as low as 0.6 ppm/ $^{\circ}$ C over the full military temperature range.

These references are specifically designed to be used with the Crystal Semiconductor line of successive-approximation type Analog-to-Digital Converters (ADCs). This line of ADCs sets new standards for temperature drift, which can only be as good as the external reference used. The Thaler VRE204 combined with a Crystal ADC will provide the lowest drift data conversion obtainable.

VRE204 series devices are available in two operating temperature ranges, -25 $^{\circ}$ C to +85 $^{\circ}$ C and -55 $^{\circ}$ C to +125 $^{\circ}$ C, and two performance grades. All devices are packaged in 20 terminal LCC ceramic packages for maximum long-term stability. "M" versions are screened for high reliability and quality.

Superior stability, accuracy, and quality make the VRE204 ideal for all precision applications which may require a 4.5V reference. High-accuracy test and measurement instrumentation, and transducer excitation are some other applications which can benefit from the high accuracy of the VRE204.

### SELECTION GUIDE

Type	Output	Temperature Operating Range	Max. Volt Deviation
VRE204C	+4.5V	-25 $^{\circ}$ C to +85 $^{\circ}$ C	0.4mV
VRE204CA	+4.5V	-25 $^{\circ}$ C to +85 $^{\circ}$ C	0.2mV
VRE204M	+4.5V	-55 $^{\circ}$ C to +125 $^{\circ}$ C	0.6mV
VRE204MA	+4.5V	-55 $^{\circ}$ C to +125 $^{\circ}$ C	0.3mV

# ELECTRICAL SPECIFICATIONS

# VRE204

Vps = ±15V, T = 25°C, RL = 10KΩ unless otherwise noted.

MODEL	C			CA			M			MA			
PARAMETERS	MIN	TYP	MAX	MIN	TYP	MAX	MIN	TYP	MAX	MIN	TYP	MAX	UNITS
<b>ABSOLUTE MAXIMUM RATINGS</b>													
Power Supply	+13.5		+22	*		*	*		*	*		*	V
Operating Temperature	-25		85	*		*	-55		125	-55		125	°C
Storage Temperature	-65		150	*		*	*		*	*		*	°C
Short Circuit Protection	Continuous				*			*			*		
<b>OUTPUT VOLTAGE</b>													
VRE204		+4.5			*			*			*		V
<b>OUTPUT VOLTAGE ERRORS</b>													
Initial Error			800			400			800			400	μV
Warmup Drift		2			1			2		*			ppm
T <sub>min</sub> - T <sub>max</sub> (1)			400			200			600		*		μV
Long-Term Stability		6			*			*		*			ppm/1000hrs
Noise (.1-10Hz)		3			*			*		*			μVpp
<b>OUTPUT CURRENT</b>													
Range	±10			*			*			*			mA
<b>REGULATION</b>													
Line		6	10		*	*		*	*		*	*	ppm/V
Load		3			*			*			*		ppm/mA
<b>OUTPUT ADJUSTMENT</b>													
Range		10			*			*			*		mV
Temperature Coeff.		4			*			*			*		μV/°C/mV
<b>POWER SUPPLY CURRENTS</b> (2)													
VRE204 +PS		5	7		*	*		*	*		*	*	mA

NOTES: \*Same as C Models.

1. Using the box method, the specified value is the maximum deviation from the output voltage at 25°C over the specified operating temperature range.

2. The specified values are unloaded.

# TYPICAL PERFORMANCE CURVES

**V<sub>OUT</sub> vs. TEMPERATURE**

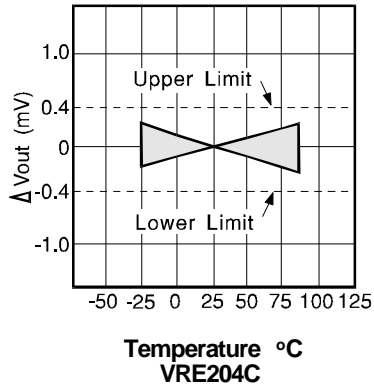

**V<sub>OUT</sub> vs. TEMPERATURE**

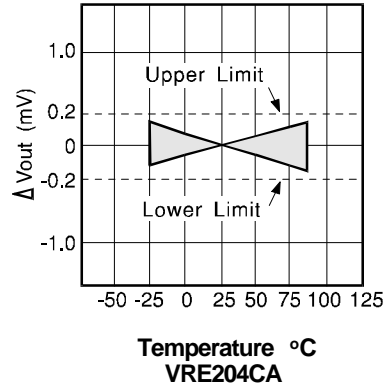

**V<sub>OUT</sub> vs. TEMPERATURE**

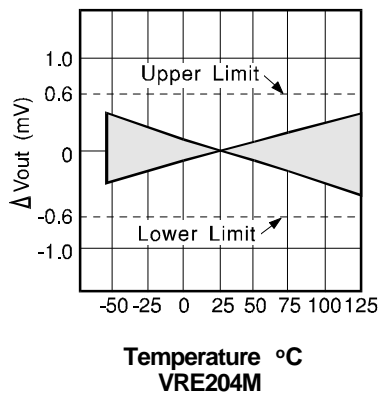

**V<sub>OUT</sub> vs. TEMPERATURE**

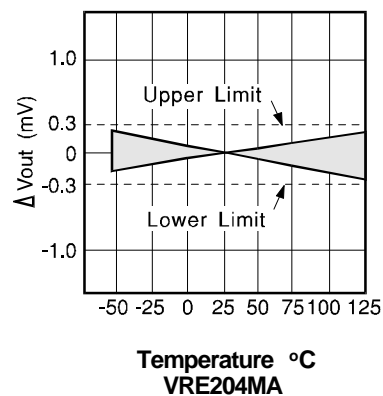

**QUIESCENT CURRENT vs. TEMP**

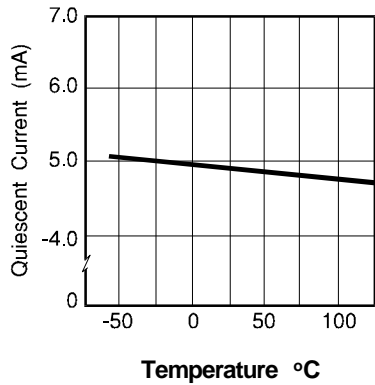

**JUNCTION TEMP. RISE vs. OUTPUT CURRENT**

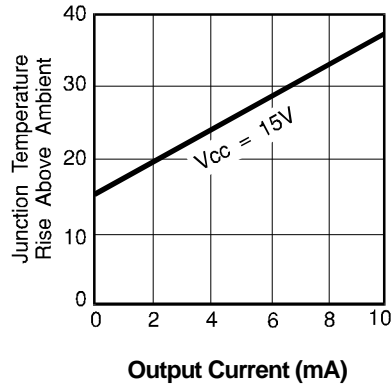

**PSRR vs. FREQUENCY**

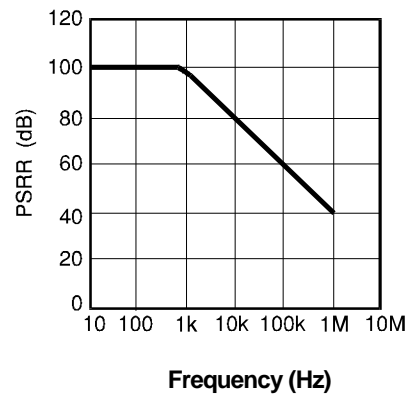

## DISCUSSION OF PERFORMANCE

### THEORY OF OPERATION

The following discussion refers to the schematic below. A FET current source is used to bias a 6.3 zener diode. The zener voltage is divided by the resistor network R1 and R2. This voltage is then applied to the noninverting input of the operational amplifier which amplifies the voltage to produce a 4.5000V output. The gain is determined by the resistor networks R3 and R4:  $G=1 + R4/R3$ . The 6.3 zener diode is used because it is the most stable diode over time and temperature.

The current source provides a closely regulated zener current, which determines the slope of the references' voltage vs. temperature function. By trimming the zener current a lower drift over temperature can be achieved. But since the voltage vs. temperature function is nonlinear this compensation technique is not well suited for wide temperature ranges.

Thaler Corporation has developed a nonlinear compensation network of thermistors and resistors that is used in the VRE series voltage references. This proprietary network eliminates most of the nonlinearity in the voltage vs. temperature function. By then adjusting the slope, Thaler Corporation produces a very stable voltage over wide temperature ranges. This network is less than 2% of the overall network resistance so it has a negligible effect on long term stability. By using highly stable resistors in our network, we produce a voltage reference that also has very good long term stability.

### APPLICATION INFORMATION

Figure 2 shows the proper connection of the VRE204 series voltage references with the optional trim resistors. Pay careful attention to the circuit layout to avoid noise pickup and voltage drops in the lines.

The VRE204 series voltage references have the ground terminal brought out on two pins (pin 9 and pin 10) which are connected together internally. This allows the user to achieve greater accuracy when using a socket. Voltage references have a voltage drop across their power supply ground pin due to quiescent current flowing through the contact resistance. If the contact resistance was constant with time and temperature, this voltage drop could be trimmed out. When the reference is plugged into a socket, this source of error can be as high as 20ppm. By connecting pin 10 to the power supply ground and pin 9 to a high impedance ground point in the measurement circuit, the error due to the contact resistance can be eliminated. If the unit is soldered into place, the contact resistance is sufficiently small that it does not effect performance.

## VRE204

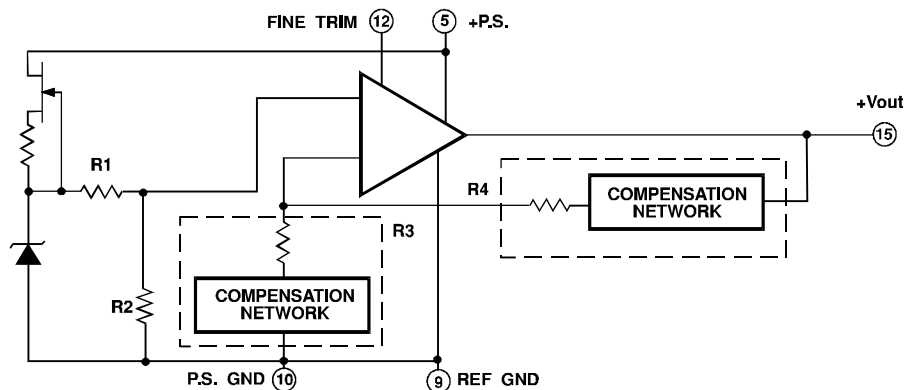

FIGURE 1

## EXTERNAL CONNECTIONS

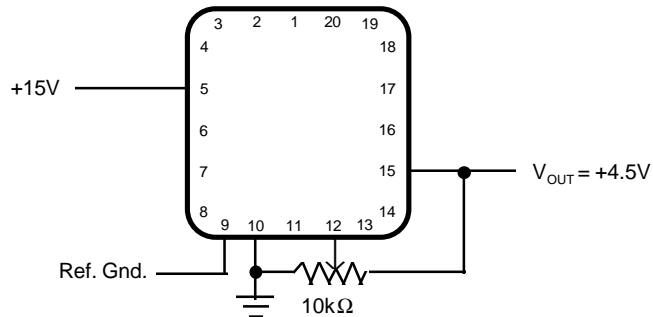
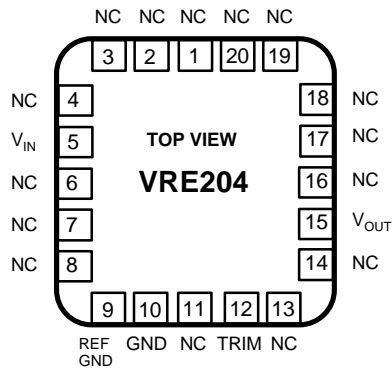
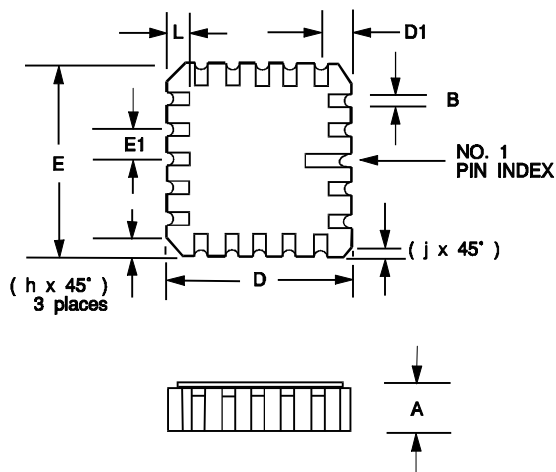

FIGURE 2

## PIN CONFIGURATION



## MECHANICAL



DIM	INCHES		MILLIMETER	
	MIN	MAX	MIN	MAX
A	0.090	0.110	2.29	2.79
B	0.022	0.028	0.56	0.71
D	0.342	0.358	8.68	9.09
D1	0.048	0.052	1.22	1.32
E	0.342	0.358	8.68	9.09
E1	0.045	0.055	1.114	1.40
j	0.010 REF		.254 REF	
h	0.040 REF		1.02 REF	
L	0.045	0.055	1.14	1.40



# VRE205

## Precision Surface Mount Reference Supply

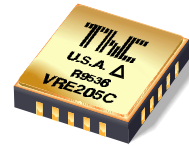

THALER CORPORATION • 2015 N. FORBES BOULEVARD • TUCSON, AZ. 85745 • (520) 882-4000

### FEATURES

- PIN AND FUNCTION COMPATIBLE TO REF02
- VERY HIGH ACCURACY: 5.000 V OUTPUT  $\pm 0.4$  mV
- EXTREMELY LOW DRIFT: 0.6 ppm/ $^{\circ}$ C -55 $^{\circ}$ C to +125 $^{\circ}$ C
- EXCELLENT STABILITY: 6 ppm/1000 Hrs. Typ.
- EXCELLENT LINE REGULATION: 6 ppm/V Typ.
- WIDE SUPPLY RANGE: +13.5 V to -22.0 V
- HERMETIC 20 TERMINAL CERAMIC LCC
- MILITARY PROCESSING OPTION

### APPLICATIONS

- PRECISION A/D and D/A CONVERTERS
- TRANSDUCER EXCITATION
- ACCURATE COMPARATOR THRESHOLD REFERENCE
- HIGH RESOLUTION SERVO SYSTEMS
- DIGITAL VOLTMETERS
- HIGH PRECISION TEST and MEASUREMENT INSTRUMENTS

### DESCRIPTION

VRE205 Series Precision Voltage References provides ultrastable +5.000 V outputs with  $\pm 0.4$  mV initial accuracy and temperature coefficient as low as 0.6 ppm/ $^{\circ}$ C over the full military temperature range. This improvement in accuracy is made possible by a unique, proprietary multipoint laser compensation technique developed by Thaler Corporation. Significant improvements have been made in other performance parameters as well, including initial accuracy, warm-up drift, line regulation, and long-term stability, making the VRE205 series the most accurate and stable 5V references available.

VRE205 series devices are available in two operating temperature ranges, -25 $^{\circ}$ C to +85 $^{\circ}$ C and -55 $^{\circ}$ C to +125 $^{\circ}$ C, and two performance grades. All devices are packaged in 20 terminal ceramic LCC packages for maximum long-term stability. "M" versions are screened for high reliability and quality.

### SELECTION GUIDE

Type	Output	Temperature Operating Range	Max. Volt Deviation
VRE205C	+5V	-25 $^{\circ}$ C to +85 $^{\circ}$ C	0.4mV
VRE205CA	+5V	-25 $^{\circ}$ C to +85 $^{\circ}$ C	0.2mV
VRE205M	+5V	-55 $^{\circ}$ C to +125 $^{\circ}$ C	0.6mV
VRE205MA	+5V	-55 $^{\circ}$ C to +125 $^{\circ}$ C	0.3mV

# ELECTRICAL SPECIFICATIONS

# VRE205

Vps = ±15V, T = 25°C, RL = 10KΩ unless otherwise noted.

MODEL	C			CA			M			MA			
PARAMETERS	MIN	TYP	MAX	MIN	TYP	MAX	MIN	TYP	MAX	MIN	TYP	MAX	UNITS
<b>ABSOLUTE MAXIMUM RATINGS</b>													
Power Supply	+13.5		+22	*		*	*		*	*		*	V
Operating Temperature	-25		85	*		*	-55		125	-55		125	°C
Storage Temperature	-65		150	*		*	*		*	*		*	°C
Short Circuit Protection	Continuous				*			*			*		
<b>OUTPUT VOLTAGE</b>													
VRE205		+5			*			*			*		V
<b>OUTPUT VOLTAGE ERRORS</b>													
Initial Error			800			400			800			400	μV
Warmup Drift		2			1			2			1		ppm
T <sub>min</sub> - T <sub>max</sub> (1)			400			200			600			300	μV
Long-Term Stability		6			*			*			*		ppm/1000hrs
Noise (.1-10Hz)		3			*			*			*		μVpp
<b>OUTPUT CURRENT</b>													
Range	±10			*			*			*			mA
<b>REGULATION</b>													
Line		6	10		*	*		*	*		*	*	ppm/V
Load		3			*			*			*		ppm/mA
<b>OUTPUT ADJUSTMENT</b>													
Range		10			*			*			*		mV
Temperature Coeff.		4			*			*			*		μV/°C/mV
<b>POWER SUPPLY CURRENTS</b> (2)													
VRE205 +PS		5	7		*	*		*	*		*	*	mA

NOTES: \*Same as C Models.

1. Using the box method, the specified value is the maximum deviation from the output voltage at 25°C over the specified operating temperature range.

2. The specified values are unloaded.

# TYPICAL PERFORMANCE CURVES

**V<sub>OUT</sub> vs. TEMPERATURE**

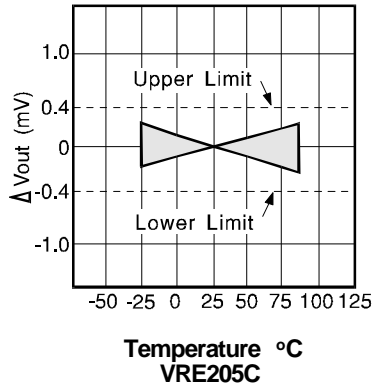

**V<sub>OUT</sub> vs. TEMPERATURE**

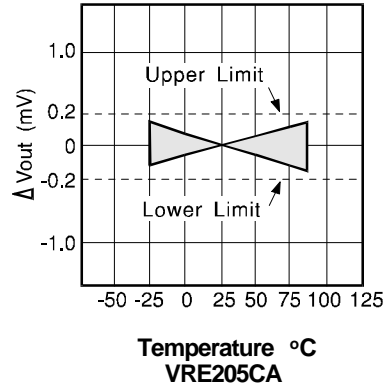

**V<sub>OUT</sub> vs. TEMPERATURE**

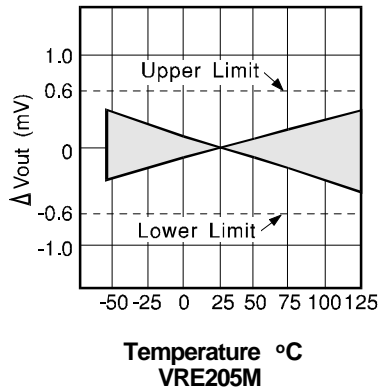

**V<sub>OUT</sub> vs. TEMPERATURE**

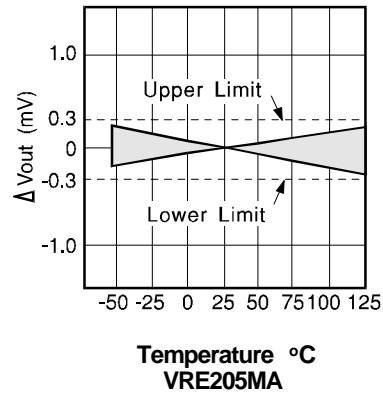

**QUIESCENT CURRENT vs. TEMP**

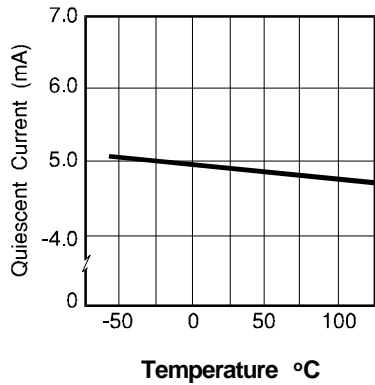

**JUNCTION TEMP. RISE vs. OUTPUT CURRENT**

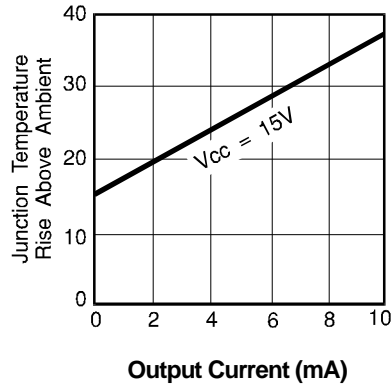

**PSRR vs. FREQUENCY**

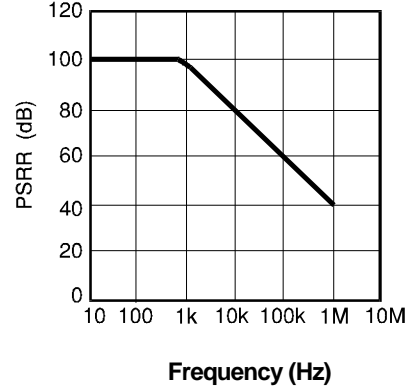



## EXTERNAL CONNECTIONS

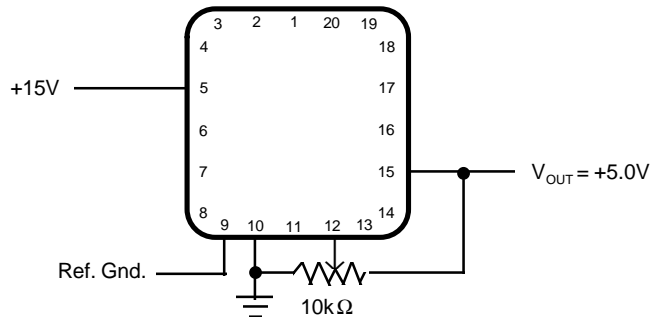
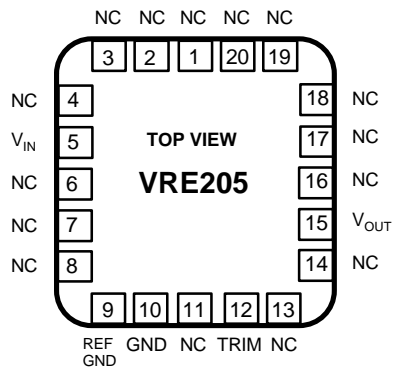
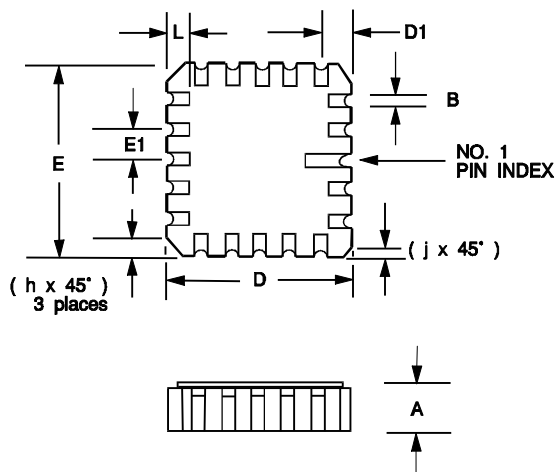

FIGURE 2

## PIN CONFIGURATION



## MECHANICAL



DIM	INCHES		MILLIMETER	
	MIN	MAX	MIN	MAX
A	0.090	0.110	2.29	2.79
B	0.022	0.028	0.56	0.71
D	0.342	0.358	8.68	9.09
D1	0.048	0.052	1.22	1.32
E	0.342	0.358	8.68	9.09
E1	0.045	0.055	1.114	1.40
j	0.010 REF		.254 REF	
h	0.040 REF		1.02 REF	
L	0.045	0.055	1.14	1.40



# VRE210

## Precision Surface Mount Reference Supplies

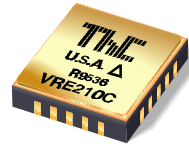

THALER CORPORATION • 2015 N. FORBES BOULEVARD • TUCSON, AZ. 85745 • (520) 882-4000

### FEATURES

- PIN AND FUNCTION COMPATIBLE WITH REF01
- VERY HIGH ACCURACY: 10.000 V OUTPUT  $\pm 0.3$  mV
- EXTREMELY LOW DRIFT: 0.5 ppm/ $^{\circ}$ C 55 $^{\circ}$ C to +125 $^{\circ}$ C
- LOW WARM-UP DRIFT: 1 ppm Typ.
- EXCELLENT STABILITY: 6 ppm/1000 Hrs. Typ.
- EXCELLENT LINE REGULATION: 3 ppm/V Typ.
- HERMETIC 20 TERMINAL CERAMIC LCC
- MILITARY PROCESSING OPTION

### DESCRIPTION

VRE210 Series Precision Voltage References provide ultrastable +10.000V outputs with  $\pm 0.3$  mV initial accuracy and temperature coefficient as low as 0.5 ppm/ $^{\circ}$ C over the full military temperature range. This improvement in accuracy is made possible by a unique, proprietary multipoint laser compensation technique developed by Thaler Corporation. Significant improvements have been made in other performance parameters as well, including initial accuracy, warm-up drift, line regulation, and long-term stability, making the VRE210 series the most accurate and stable 10V surface mount references available.

VRE210 devices are available in two operating temperature ranges, -25 $^{\circ}$ C to +85 $^{\circ}$ C and -55 $^{\circ}$ C to +125 $^{\circ}$ C, and two electrical performance grades. All devices are packaged in 20 terminal ceramic LCC packages for maximum long-term stability. "M" versions are screened for high reliability and quality.

### APPLICATIONS

- PRECISION A/D and D/A CONVERTERS
- TRANSDUCER EXCITATION
- ACCURATE COMPARATOR THRESHOLD REFERENCE
- HIGH RESOLUTION SERVO SYSTEMS
- DIGITAL VOLTMETERS
- HIGH PRECISION TEST and MEASUREMENT INSTRUMENTS

### SELECTION GUIDE

Type	Output	Temperature Operating Range	Max. Volt Deviation
VRE210C	+10V	-25 $^{\circ}$ C to +85 $^{\circ}$ C	0.6mV
VRE210CA	+10V	-25 $^{\circ}$ C to +85 $^{\circ}$ C	0.3mV
VRE210M	+10V	-55 $^{\circ}$ C to +125 $^{\circ}$ C	1.0mV
VRE210MA	+10V	-55 $^{\circ}$ C to +125 $^{\circ}$ C	0.5mV

# ELECTRICAL SPECIFICATIONS

# VRE210

Vps = ±15V, T = 25°C, RL = 10KΩ unless otherwise noted.

MODEL	C			CA			M			MA			
PARAMETERS	MIN	TYP	MAX	MIN	TYP	MAX	MIN	TYP	MAX	MIN	TYP	MAX	UNITS
<b>ABSOLUTE MAXIMUM RATINGS</b>													
Power Supply	+13.5		+22	*		*	*		*	*		*	V
Operating Temperature	-25		85	*		*	-55		125	-55		125	°C
Storage Temperature	-65		150	*		*	*		*	*		*	°C
Short Circuit Protection	Continuous				*			*			*		
<b>OUTPUT VOLTAGE</b>													
VRE210		+10			*			*			*		V
<b>OUTPUT VOLTAGE ERRORS</b>													
Initial Error			500			300			800			400	μV
Warmup Drift		2			1			2			1		ppm
T <sub>min</sub> - T <sub>max</sub> <sup>(1)</sup>			600			300			1000			500	μV
Long-Term Stability		6			*			*			*		ppm/1000hrs
Noise (.1-10Hz)		6			*			*			*		μVpp
<b>OUTPUT CURRENT</b>													
Range	±10			*			*			*			mA
<b>REGULATION</b>													
Line		3	10		*	*		*	*		*	*	ppm/V
Load		3			*			*			*		ppm/mA
<b>OUTPUT ADJUSTMENT</b>													
Range		20			*			*			*		mV
Temperature Coeff.		4			*			*			*		mV/°C/mV
<b>POWER SUPPLY CURRENTS</b> <sup>(2)</sup>													
VRE210 +PS		5	7		*	*		*	*		*	*	mA

NOTES: \*Same as C Models.

1. Using the box method, the specified value is the maximum deviation from the output voltage at 25°C over the specified operating temperature range.

2. The specified values are unloaded.

# TYPICAL PERFORMANCE CURVES

**V<sub>OUT</sub> vs. TEMPERATURE**

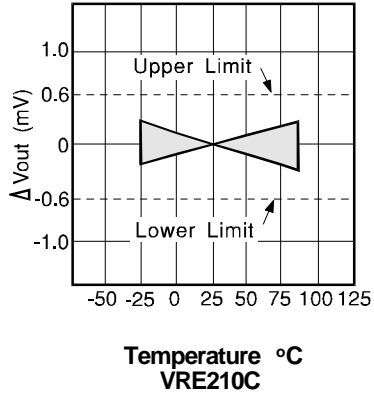

**V<sub>OUT</sub> vs. TEMPERATURE**

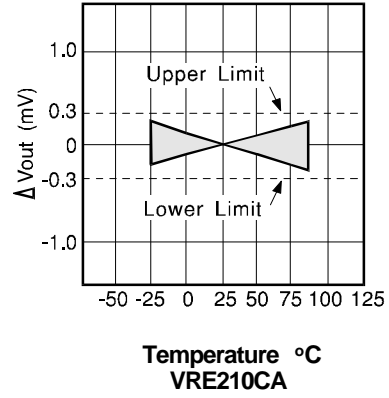

**V<sub>OUT</sub> vs. TEMPERATURE**

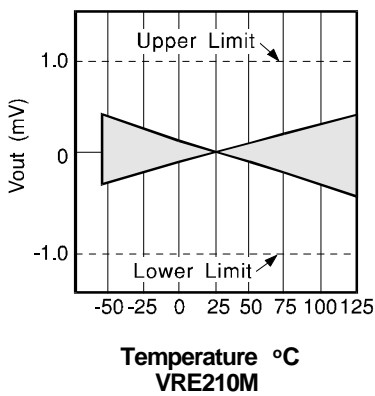

**V<sub>OUT</sub> vs. TEMPERATURE**

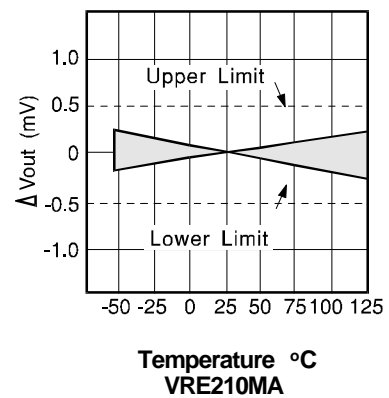

**QUIESCENT CURRENT vs. TEMP**

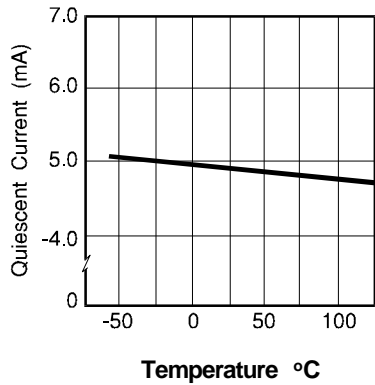

**JUNCTION TEMP. RISE vs. OUTPUT CURRENT**

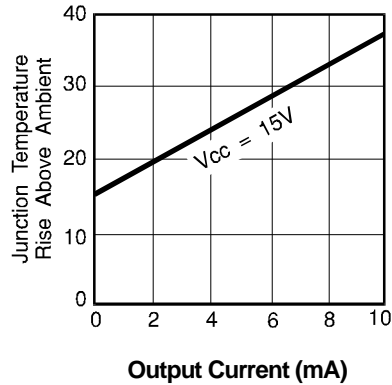

**PSRR vs. FREQUENCY**

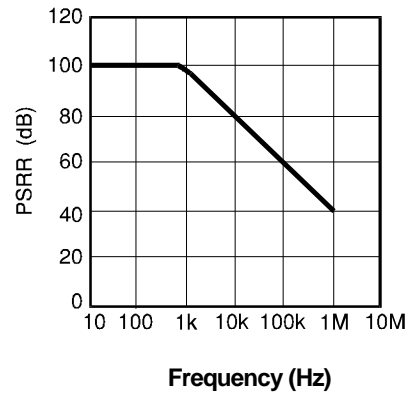

## DISCUSSION OF PERFORMANCE

### THEORY OF OPERATION

The following discussion refers to the schematic below. In operation, approximately 6.3 volts is applied to the noninverting input of the op amp. The voltage is amplified by the op amp to produce a 10.000V output. The gain is determined by the networks R1 and R2:  $G=1 + R2/R1$ . The 6.3V zener diode is used because it is the most stable diode over time and temperature.

The zener operating current is derived from the regulated output voltage through R3. This feedback arrangement provides a closely regulated zener current. This current determines the slope of the references' voltage vs. temperature function. By trimming the zener current a lower drift over temperature can be achieved. But since the voltage vs. temperature function is nonlinear this compensation technique is not well suited for wide temperature ranges.

Thaler Corporation has developed a nonlinear compensation network of thermistors and resistors that is used in the VRE series voltage references. This proprietary network eliminates most of the nonlinearity in the voltage vs. temperature function. By then adjusting the slope, Thaler Corporation produces a very stable voltage over wide temperature ranges. This network is less than 2% of the overall network resistance so it has a negligible effect on long term stability. By using highly stable resistors in our network, we produce a voltage reference that also has very good long term stability.

### APPLICATION INFORMATION

Figure 2 shows the proper connection of the VRE210 series voltage references with the optional trim resistors. Pay careful attention to the circuit layout to avoid noise pickup and voltage drops in the lines.

The VRE210 series voltage references have the ground terminal brought out on two pins (pin 9 and pin 10) which are connected together internally. This allows the user to achieve greater accuracy when using a socket. Voltage references have a voltage drop across their power supply ground pin due to quiescent current flowing through the contact resistance. If the contact resistance was constant with time and temperature, this voltage drop could be trimmed out. When the reference is plugged into a socket, this source of error can be as high as 20ppm. By connecting pin 10 to the power supply ground and pin 9 to a high impedance ground point in the measurement circuit, the error due to the contact resistance can be eliminated. If the unit is soldered into place, the contact resistance is sufficiently small that it does not effect performance.

### VRE210

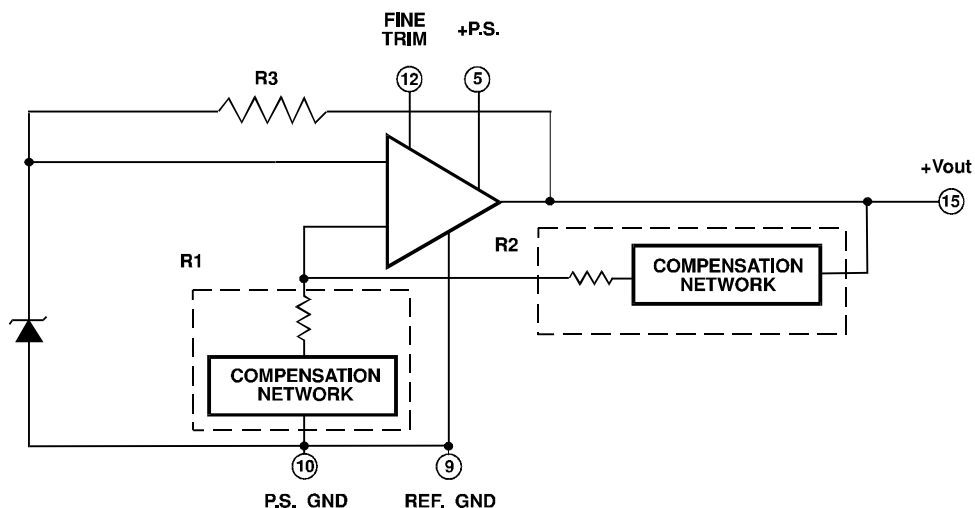

FIGURE 1

## EXTERNAL CONNECTIONS

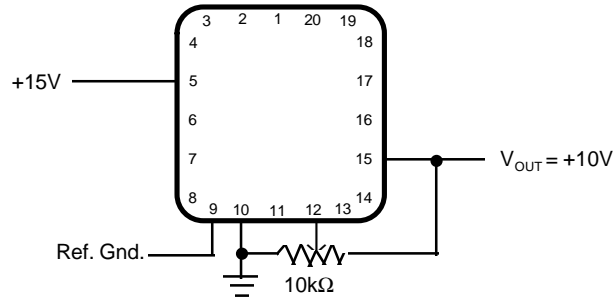
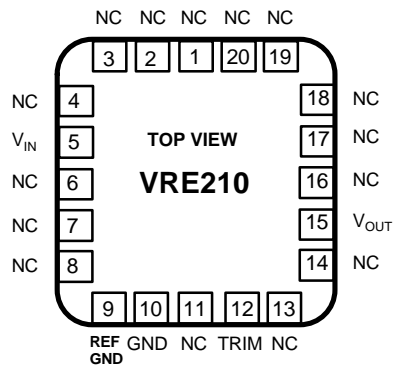
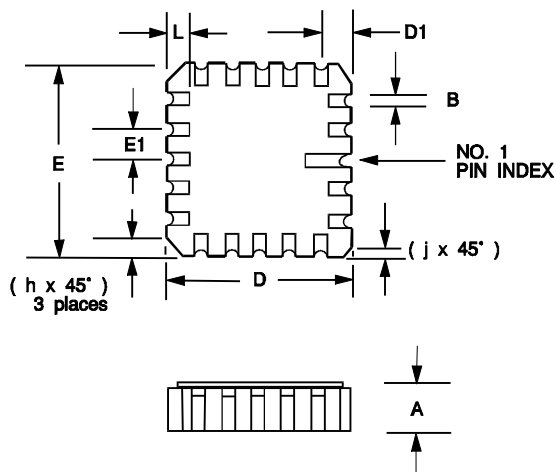

FIGURE 2

## PIN CONFIGURATION



## MECHANICAL



DIM	INCHES		MILLIMETER	
	MIN	MAX	MIN	MAX
A	0.090	0.110	2.29	2.79
B	0.022	0.028	0.56	0.71
D	0.342	0.358	8.68	9.09
D1	0.048	0.052	1.22	1.32
E	0.342	0.358	8.68	9.09
E1	0.045	0.055	1.114	1.40
j	0.010 REF		.254 REF	
h	0.040 REF		1.02 REF	
L	0.045	0.055	1.14	1.40