



# WM8985

## Multimedia CODEC With Class D Headphone and Line Out

### DESCRIPTION

The WM8985 is a low power, high quality, feature-rich stereo codec designed for portable multimedia applications that require low power consumption and high quality audio.

The device integrates preamps for stereo differential mics, and includes class D and class AB drivers for headphone and differential or stereo line output. External component requirements are reduced as no separate microphone or headphone amplifiers are required.

Advanced DSP features include a 5-band equaliser, an ALC/limiter for the microphone or line input through the ADC and a digital playback limiter. Additional digital filtering options are available in the ADC path, to cater for application filtering such as 'wind noise reduction' and a programmable notch filter. Highly flexible mixers enable many new application features, with the option to record and playback any combination of voice, line inputs and digital audio such as FM Radio or MP3.

The WM8985 digital audio interface can operate in master or slave mode, while an integrated PLL provides flexible clocking schemes.

The WM8985 operates at analogue supply voltages from 2.5V to 3.3V, although the digital core can operate at voltages down to 1.71V to save power. Additional power management control enables individual sections of the chip to be powered down under software control.

### FEATURES

#### Stereo Codec:

- DAC SNR 98dB, THD -86dB ('A' weighted @ 48kHz)
- ADC SNR 92.5dB, THD -75dB ('A' weighted @ 48kHz)
- Headphone driver with 'capless' option
  - 40mW/channel output power into 16Ω / 3.3V AVDD2
  - Class D headphone driver
  - Class AB headphone / line Driver
  - PSRR 70dB at 217Hz
- Stereo, mono or differential line output

#### Mic Preamps:

- Stereo differential or mono microphone interfaces
- Programmable preamp gain
- Pseudo differential inputs with common mode rejection
- Programmable ALC / Noise Gate in ADC path
- Low-noise bias supplied for electret microphones

#### Other Features:

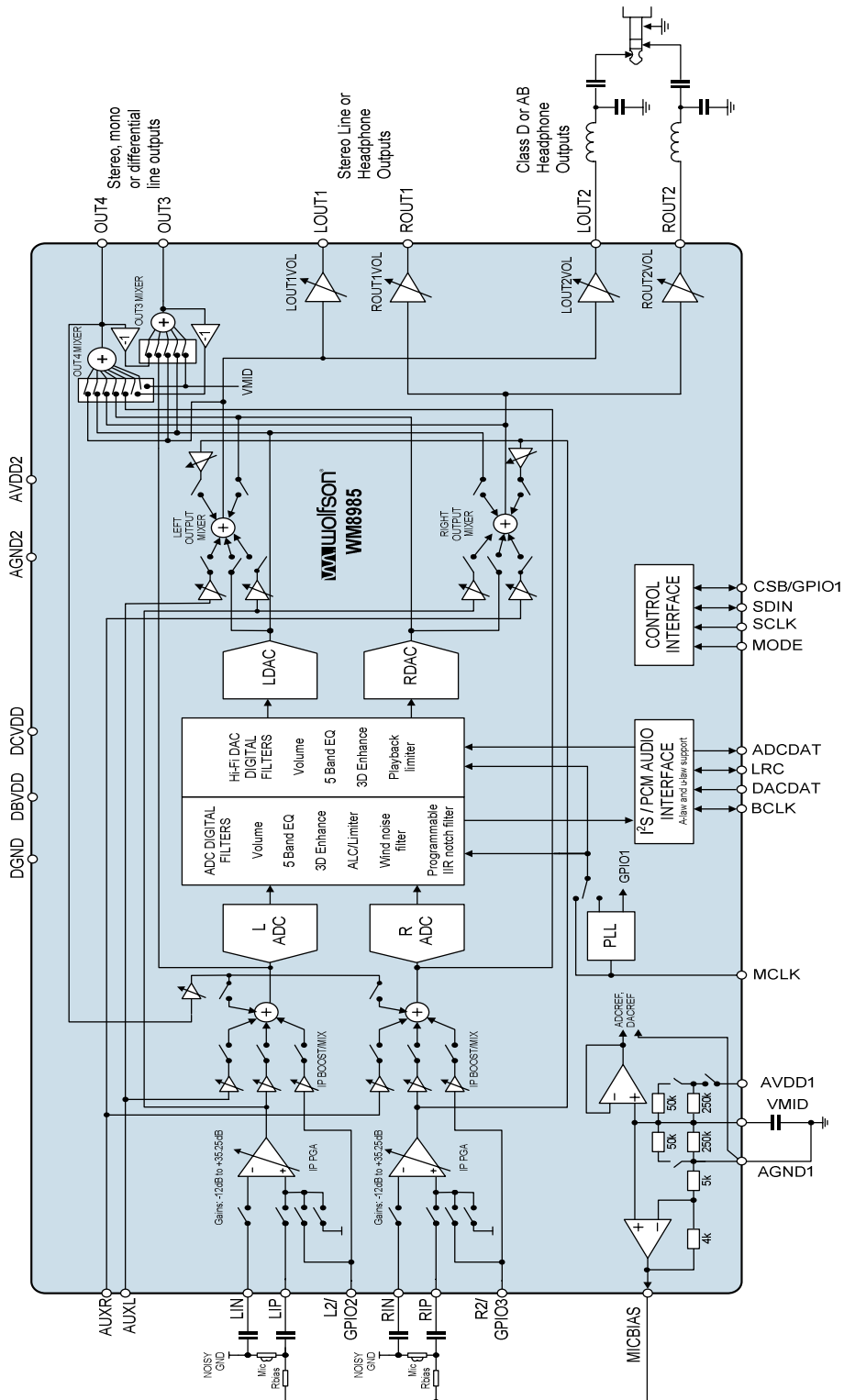
- Enhanced 3-D function for improved stereo separation
- Digital playback limiter
- 5-band Equaliser (record or playback)
- Programmable ADC High Pass Filter (wind noise reduction)
- Programmable ADC Notch Filter
- Aux inputs for stereo analog input signals or 'beep'
- PLL supporting various clocks between 8MHz-50MHz
- Sample rates supported (kHz): 8, 11.025, 16, 12, 16, 22.05, 24, 32, 44.1, 48
- Low power, low voltage
- 2.5V to 3.6V analogue supplies
- 1.71V to 3.6V digital supplies
- 5x5mm 32-lead QFN package

### APPLICATIONS

- Portable audio player / FM radio
- Multimedia Mobile Handsets



BLOCK DIAGRAM



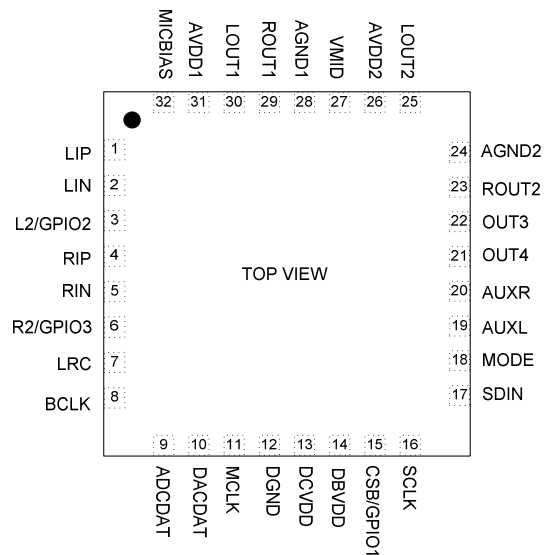
## TABLE OF CONTENTS

<b>DESCRIPTION</b> .....	<b>1</b>
<b>FEATURES</b> .....	<b>1</b>
<b>APPLICATIONS</b> .....	<b>1</b>
<b>BLOCK DIAGRAM</b> .....	<b>2</b>
<b>PIN CONFIGURATION</b> .....	<b>5</b>
<b>ORDERING INFORMATION</b> .....	<b>5</b>
<b>PIN DESCRIPTION</b> .....	<b>6</b>
<b>ABSOLUTE MAXIMUM RATINGS</b> .....	<b>7</b>
<b>RECOMMENDED OPERATING CONDITIONS</b> .....	<b>7</b>
<b>ELECTRICAL CHARACTERISTICS</b> .....	<b>8</b>
TERMINOLOGY .....	14
<b>AUDIO PATHS OVERVIEW</b> .....	<b>16</b>
<b>SIGNAL TIMING REQUIREMENTS</b> .....	<b>17</b>
SYSTEM CLOCK TIMING .....	17
AUDIO INTERFACE TIMING – MASTER MODE .....	17
AUDIO INTERFACE TIMING – SLAVE MODE.....	18
CONTROL INTERFACE TIMING – 3-WIRE MODE .....	19
CONTROL INTERFACE TIMING – 2-WIRE MODE .....	20
<b>INTERNAL POWER ON RESET CIRCUIT</b> .....	<b>21</b>
RECOMMENDED POWER UP/DOWN SEQUENCE .....	23
<b>DEVICE DESCRIPTION</b> .....	<b>27</b>
INTRODUCTION.....	27
INPUT SIGNAL PATH.....	28
ANALOGUE TO DIGITAL CONVERTER (ADC).....	38
INPUT LIMITER / AUTOMATIC LEVEL CONTROL (ALC) .....	42
LIMITER MODE.....	45
OUTPUT SIGNAL PATH.....	54
3D STEREO ENHANCEMENT .....	61
ANALOGUE OUTPUTS.....	61
DIGITAL AUDIO INTERFACES.....	74
AUDIO SAMPLE RATES.....	78
MASTER CLOCK AND PHASE LOCKED LOOP (PLL) .....	79
COMPANDING.....	81
GENERAL PURPOSE INPUT/OUTPUT .....	83
OUTPUT SWITCHING (JACK DETECT).....	84
CONTROL INTERFACE.....	85
RESETTING THE CHIP .....	86
POWER SUPPLIES .....	86
POWER MANAGEMENT .....	87
<b>REGISTER MAP</b> .....	<b>89</b>
REGISTER BITS BY ADDRESS .....	91
<b>DIGITAL FILTER CHARACTERISTICS</b> .....	<b>109</b>
TERMINOLOGY .....	109
DAC FILTER RESPONSES.....	110
ADC FILTER RESPONSES.....	110
HIGHPASS FILTER.....	111
5-BAND EQUALISER.....	112

---

<b>APPLICATIONS INFORMATION .....</b>	<b>116</b>
RECOMMENDED EXTERNAL COMPONENTS .....	116
<b>PACKAGE DIAGRAM .....</b>	<b>117</b>
ADDRESS: .....	118

## PIN CONFIGURATION



## ORDERING INFORMATION

ORDER CODE	TEMPERATURE RANGE	PACKAGE	MOISTURE SENSITIVITY LEVEL	PEAK SOLDERING TEMPERATURE
WM8985GEFL	-25°C to +85°C	32-lead QFN (5 x 5 mm) (Pb-free)	MSL1	260°C
WM8985GEFL/R	-25°C to +85°C	32-lead QFN (5 x 5 mm) (Pb-free, tape and reel)	MSL1	260°C

**Note:**

Reel quantity = 3,500

## PIN DESCRIPTION

PIN	NAME	TYPE	DESCRIPTION
1	LIP	Analogue input	Left MIC pre-amp positive input
2	LIN	Analogue input	Left MIC pre-amp negative input
3	L2/GPIO2	Analogue input	Left channel line input/secondary mic pre-amp positive input/GPIO2 pin
4	RIP	Analogue input	Right MIC pre-amp positive input
5	RIN	Analogue input	Right MIC pre-amp negative input
6	R2/GPIO3	Analogue input	Right channel line input/secondary mic pre-amp positive input/GPIO3 pin
7	LRC	Digital Input / Output	DAC and ADC sample rate clock
8	BCLK	Digital Input / Output	Digital audio bit clock
9	ADCDAT	Digital Output	ADC digital audio data output
10	DACDAT	Digital Input	DAC digital audio data input
11	MCLK	Digital Input	Master clock input
12	DGND	Supply	Digital ground
13	DCVDD	Supply	Digital core logic supply
14	DBVDD	Supply	Digital buffer (I/O) supply
15	CSB/GPIO1	Digital Input / Output	3-Wire control interface chip Select / GPIO1 pin
16	SCLK	Digital Input	3-Wire control interface clock input / 2-wire control interface clock input
17	SDIN	Digital Input / Output	3-Wire control interface data input / 2-Wire control interface data input
18	MODE	Digital Input	Control interface selection
19	AUXL	Analogue input	Left auxiliary input
20	AUXR	Analogue input	Right auxiliary input
21	OUT4	Analogue Output	Buffered midrail headphone pseudo-ground / right line output / mono mix output
22	OUT3	Analogue Output	Buffered midrail headphone pseudo-ground or left line output
23	ROUT2	Analogue Output	Class D or class AB headphone output right
24	AGND2	Supply	Analogue ground (ground reference for ROUT2/LOUT2 and OUT3/OUT4)
25	LOUT2	Analogue Output	Class D or class AB headphone output left
26	AVDD2	Supply	Analogue supply (feeds output amplifiers ROUT2/LOUT2 and OUT3/OUT4)
27	VMID	Reference	Decoupling for ADC and DAC reference voltage
28	AGND1	Supply	Analogue ground (ground reference for all input amplifiers, PLL, ADC and DAC, internal bias circuits, output amplifiers LOU1, ROUT1)
29	ROUT1	Analogue Output	Class AB headphone or line output right
30	LOUT1	Analogue Output	Class AB headphone or line output left
31	AVDD1	Supply	Analogue supply (feeds all input amplifiers, PLL, ADC and DAC, internal bias circuits, output amplifiers LOU1, LOU2))
32	MICBIAS	Analogue Output	Microphone bias

**Note:**

It is recommended that the QFN ground paddle should be connected to analogue ground on the application PCB. Refer to the application note WAN\_0118 on "Guidelines on How to Use QFN Packages and Create Associated PCB Footprints"

## ABSOLUTE MAXIMUM RATINGS

Absolute Maximum Ratings are stress ratings only. Permanent damage to the device may be caused by continuously operating at or beyond these limits. Device functional operating limits and guaranteed performance specifications are given under Electrical Characteristics at the test conditions specified.



ESD Sensitive Device. This device is manufactured on a CMOS process. It is therefore generically susceptible to damage from excessive static voltages. Proper ESD precautions must be taken during handling and storage of this device.

Wolfson tests its package types according to IPC/JEDEC J-STD-020B for Moisture Sensitivity to determine acceptable storage conditions prior to surface mount assembly. These levels are:

MSL1 = unlimited floor life at <30°C / 85% Relative Humidity. Not normally stored in moisture barrier bag.

MSL2 = out of bag storage for 1 year at <30°C / 60% Relative Humidity. Supplied in moisture barrier bag.

MSL3 = out of bag storage for 168 hours at <30°C / 60% Relative Humidity. Supplied in moisture barrier bag.

The Moisture Sensitivity Level for each package type is specified in Ordering Information.

CONDITION	MIN	MAX
DBVDD, DCVDD, AVDD1, AVDD2 supply voltages	-0.3V	+4.5V
Voltage range digital inputs	DGND -0.3V	DBVDD +0.3V
Voltage range analogue inputs	AGND1 -0.3V	AVDD1 +0.3V
Storage temperature prior to soldering	30°C max / 85% RH max	
Storage temperature after soldering	-65°C	+150°C

### Notes:

1. Analogue and digital grounds must always be within 0.3V of each other.
2. All digital and analogue supplies are internally independent (i.e. not connected).
3. Analogue supply voltages should not be less than digital supply voltages.
4. DBVDD must be greater than or equal to DCVDD.

## RECOMMENDED OPERATING CONDITIONS

PARAMETER	SYMBOL	TEST CONDITIONS	MIN	TYP	MAX	UNIT
Digital supply range (Core)	DCVDD		1.71 <sup>1</sup>		3.6	V
Digital supply range (Buffer)	DBVDD		1.71		3.6	V
Analogue supply range	AVDD1, AVDD2		2.5 <sup>1</sup>		3.6	V
Ground	DGND, AGND1, AGND2			0		V

### Notes:

1. Analogue supply voltages should not be less than digital supply voltages.

## ELECTRICAL CHARACTERISTICS

## Test Conditions

DCVDD=1.8V, AVDD1=AVDD2=DBVDD=3.3V, T<sub>A</sub> = +25°C, 1kHz signal, fs = 48kHz, 24-bit audio data unless otherwise stated.

PARAMETER	SYMBOL	TEST CONDITIONS	MIN	TYP	MAX	UNIT
<b>Microphone Input PGA Inputs (LIP, LIN, RIP, RIN, L2, R2)</b>						
<b>INPPGAVOLL, INPPGAVOLR, PGABOOSTL and PGABOOSTR = 0dB</b>						
Full-scale Input Signal Level – Single-ended input via LIN/RIN <sup>1</sup>				AVDD/3.3		V <sub>rms</sub>
Full-scale Input Signal Level – Pseudo-differential input <sup>1,2</sup>				AVDD*0.7/ 3.3		V <sub>rms</sub>
Input PGA equivalent input noise		INPPGAVOLL/R = +35.25dB No input signal 0 to 20kHz		150		µV
LIN, RIN input resistance		INPPGAVOLL and INPPGAVOLR = +35.25dB		1.6		kΩ
LIN, RIN input resistance		INPPGAVOLL and INPPGAVOLR = 0dB		46		kΩ
LIN, RIN input resistance		INPPGAVOLL and INPPGAVOLR = -12dB		71		kΩ
LIP, RIP input resistance		All gain settings		90		kΩ
L2, R2 input resistance		L2_2INPPGA and R2_2INPPGA = 1 L2_2BOOSTVOL and R2_2BOOSTVOL = 000		90		kΩ
L2, R2 input resistance		L2_2INPPGA and R2_2INPPGA = 0 L2_2BOOSTVOL and R2_2BOOSTVOL = +6dB		11		kΩ
L2, R2 input resistance		L2_2INPPGA and R2_2INPPGA = 0 L2_2BOOSTVOL and R2_2BOOSTVOL = 0dB		22		kΩ
L2, R2 input resistance		L2_2INPPGA and R2_2INPPGA = 0 L2_2BOOSTVOL and R2_2BOOSTVOL = -12dB		60		kΩ
Input Capacitance		All analogue input pins		10		pF
Input PGA Programmable Gain		Gain adjusted by INPPGAVOLL and INPPGAVOLR	-12		+35.25	dB
Programmable Gain Step Size		Guaranteed monotonic		0.75		dB
Input PGA Mute Attenuation		INPPGAMUTEL and INPPGAMUTER = 1		100		dB
Input Gain Boost		PGABOOSTL and PGABOOSTR = 0		0		dB
Input Gain Boost		PGABOOSTL and PGABOOSTR = 1		+20		dB

**Test Conditions**DCVDD=1.8V, AVDD1=AVDD2=DBVDD=3.3V, T<sub>A</sub> = +25°C, 1kHz signal, fs = 48kHz, 24-bit audio data unless otherwise stated.

PARAMETER	SYMBOL	TEST CONDITIONS	MIN	TYP	MAX	UNIT
<b>Auxiliary Analogue Inputs (AUXL, AUXR)</b>						
Full-scale Input Signal Level <sup>2</sup>				AVDD/3.3		V <sub>rms</sub>
Input Resistance		Left Input boost and mixer enabled, at +6dB		11		kΩ
		Left Input boost and mixer enabled, at 0dB gain		22		kΩ
		Left Input boost and mixer enabled, at -12dB gain		60		kΩ
		Right Input boost, mixer enabled, at +6dB gain		11		kΩ
		Right Input boost, mixer enabled, at 0dB gain		22		kΩ
		Right Input boost, mixer enabled, at -12dB gain		60		kΩ
Input Capacitance		All analogue Inputs		10		pF
Gain range from AUXL and AUXR input to left and right input PGA mixers		Gain adjusted by AUXL2BOOSTVOL and AUXR2BOOSTVOL	-12		+6	dB
AUXLBOOSTVOL and AUXRBOOSTVOL step size				3		dB
<b>L2, R2 Line Input Programmable Gain</b>						
Gain range from L2/R2 input to left and right input PGA mixers		Gain adjusted by L2_2BOOSTVOL and R2_2BOOSTVOL	-12		+6	dB
L2/R2_2BOOSTVOL step size				3		dB
L2/R2_2BOOSTVOL mute attenuation				100		dB
<b>OUT4 to left or right input boost record path</b>						
Gain range into left and right input PGA mixers		Gain adjusted by OUT4_2ADCVOL	-6		+12	dB
OUT4_2ADCVOL gain step size				3		dB
OUT4_2ADCVOL mute attenuation				100		dB
<b>Reference Voltage (VMID)</b>						
Reference voltage accuracy	VMID	AVDD = 3.3V		TBD		%
<b>Analogue to Digital Converter (ADC) - Input from LIN/P and RIN/P in differential configuration to input PGA INPPGAVOLL, INPPGAVOLR, PGABOOSTL, PGABOOSTR, ADCLVOL and ADCRVOL = 0dB</b>						
Signal to Noise Ratio <sup>3</sup>	SNR	A-weighted AVDD1=AVDD2=3.3V		92.5		dB
		A-weighted AVDD1=AVDD2=2.5V		91.5		dB
		22Hz to 20kHz AVDD1=AVDD2=3.3V		90		dB
		22Hz to 20kHz AVDD1=AVDD2=2.5V		90		dB
Total Harmonic Distortion <sup>4</sup>	THD	-7dBV Input AVDD1=AVDD2=3.3V		-75	-70	dBFS
		-7dBV Input AVDD1=AVDD2=2.5V		-75		dBFS
Total Harmonic Distortion + Noise <sup>5</sup>	THD+N	-7dBV Input AVDD1=AVDD2=3.3V		-72	-68	dBFS

**Test Conditions**DCVDD=1.8V, AVDD1=AVDD2=DBVDD=3.3V, T<sub>A</sub> = +25°C, 1kHz signal, fs = 48kHz, 24-bit audio data unless otherwise stated.

PARAMETER	SYMBOL	TEST CONDITIONS	MIN	TYP	MAX	UNIT
		-7dBV Input AVDD1=AVDD2=2.5V		-72		dBFS
Channel Separation <sup>6</sup>		1kHz full scale input signal		100		dBFS
<b>Analogue to Digital Converter (ADC) - Input from L2, R2 into left and right PGA mixer. INPPGAVOLL, INPPGAVOLR, L2_2BOOSTVOL, R2_2BOOSTVOL, ADCLVOL and ADCRVOL = 0dB</b>						
Signal to Noise Ratio <sup>3</sup>	SNR	A-weighted AVDD1=AVDD2=3.3V	85	92.5		dB
		A-weighted AVDD1=AVDD2=2.5V		92.5		dB
		22Hz to 20kHz AVDD1=AVDD2=3.3V		90		dB
		22Hz to 20kHz AVDD1=AVDD2=2.5V		90		dB
Total Harmonic Distortion <sup>4</sup>	THD	-1dBV Input AVDD1=AVDD2=3.3V		-83	-78	dBFS
		-1dBV Input AVDD1=AVDD2=2.5V		-66		dBFS
Total Harmonic Distortion + Noise <sup>5</sup>	THD+N	-1dBV Input AVDD1=AVDD2=3.3V		-81	-70	dBFS
		-1dBV Input AVDD1=AVDD2=2.5V		-65		dBFS
Channel Separation <sup>6</sup>		1kHz input signal		100		dBFS
<b>DAC to left and right mixers into 10kΩ / 50pF load on LOUT1 and ROUT1 LOUT1VOL, ROUT1VOL, DACLVOL and DACRVOL = 0dB</b>						
Full-scale output <sup>1</sup>		LOUT1VOL and ROUTVOL = 0dB		AVDD1/3.3		V <sub>rms</sub>
Signal to Noise Ratio <sup>3</sup>	SNR	A-weighted AVDD1=AVDD2=3.3V		98		dB
		A-weighted AVDD1=AVDD2=2.5V		96		dB
		22Hz to 20kHz AVDD1=AVDD2=3.3V		95.5		dB
		22Hz to 20kHz AVDD1=AVDD2=2.5V		93.5		dB
Total Harmonic Distortion <sup>4</sup>	THD	0dBFS input AVDD1=AVDD2=3.3V		-84		dBFS
		0dBFS input AVDD1=AVDD2=2.5V		-84		dBFS
Total Harmonic Distortion + Noise <sup>5</sup>	THD+N	0dBFS input AVDD1=AVDD2=3.3V		-82		dBFS
		0dBFS input AVDD1=AVDD2=2.5V		-82		dBFS
Channel Separation <sup>6</sup>		1kHz signal		100		dB

**Test Conditions**DCVDD=1.8V, AVDD1=AVDD2=DBVDD=3.3V, T<sub>A</sub> = +25°C, 1kHz signal, fs = 48kHz, 24-bit audio data unless otherwise stated.

PARAMETER	SYMBOL	TEST CONDITIONS	MIN	TYP	MAX	UNIT
<b>DAC to L/R mixer into 10kΩ / 50pF load on L/ROUT2, class AB mode</b> <b>LOUT2VOL, ROUT2VOL, DACLVOL and DACRVOL = 0dB</b>						
Full-scale output <sup>1</sup>		LOUT2VOL and ROUT2VOL = 0dB		AVDD1/3.3		V <sub>rms</sub>
Signal to Noise Ratio <sup>3</sup>	SNR	A-weighted AVDD1=AVDD2=3.3V		100		dB
		A-weighted AVDD1=AVDD2=2.5V		96		dB
		22Hz to 20kHz AVDD1=AVDD2=3.3V		95.5		dB
		22Hz to 20kHz AVDD1=AVDD2=2.5V		93.5		dB
Total Harmonic Distortion <sup>4</sup>	THD	0dBFS input AVDD1=AVDD2=3.3V		-84		dBFS
		0dBFS input AVDD1=AVDD2=2.5V		-82		dBFS
Total Harmonic Distortion + Noise <sup>5</sup>	THD+N	0dBFS input AVDD1=AVDD2=3.3V		-82		dBFS
		0dBFS input AVDD1=AVDD2=2.5V		-80		dBFS
Channel Separation <sup>6</sup>		1kHz input signal		100		dB
<b>DAC to OUT3 and OUT4 mixers into OUT3/OUT4 outputs into (10kΩ / 50pF load. DACVOLL and DACVOLR = 0dB)</b>						
Full-scale output voltage				AVDD2/3.3		V <sub>rms</sub>
Signal to Noise Ratio <sup>3</sup>	SNR	A-weighted AVDD1=AVDD2=3.3V		98	92	dB
Total Harmonic Distortion <sup>4</sup>	THD	full-scale signal AVDD1=AVDD2=3.3V		-84	-80	dBFS
Total Harmonic Distortion + Noise <sup>5</sup>	THD+N	full-scale signal AVDD1=AVDD2=3.3V		-82	-78	dBFS
Channel Separation <sup>6</sup>		1kHz signal		100		dB
<b>DAC to left and right mixer into headphone 16Ω load on LOUT1 and ROUT1</b> <b>LOUT1VOL, ROUT1VOL, DACLVOL and DACRVOL = 0dB</b>						
Full-scale output				AVDD1/3.3		V <sub>rms</sub>
Signal to Noise Ratio <sup>3</sup>	SNR	A-weighted AVDD1=AVDD2=3.3V		100		dB
		22Hz to 20kHz AVDD1=AVDD2=3.3V		95.5		dB
Total Harmonic Distortion <sup>4</sup>	THD	P <sub>o</sub> = 20mW, RL=16Ω		-79		dBFS
Total Harmonic Distortion + Noise <sup>5</sup>	THD+N	P <sub>o</sub> = 20mW, RL=16Ω		-75		dBFS
Channel Separation <sup>6</sup>		1kHz signal		100		dB

**Test Conditions**DCVDD=1.8V, AVDD1=AVDD2=DBVDD=3.3V, T<sub>A</sub> = +25°C, 1kHz signal, fs = 48kHz, 24-bit audio data unless otherwise stated.

PARAMETER	SYMBOL	TEST CONDITIONS	MIN	TYP	MAX	UNIT
<b>DAC to left and right mixer into headphone 16Ω load on LOUT2 and ROUT2, Class AB mode</b> <b>LOUT2VOL, ROUT2VOL, DACLVOL and DACRVOL = 0dB</b>						
Full-scale output				AVDD1/3.3		V <sub>rms</sub>
Signal to Noise Ratio <sup>3</sup>	SNR	A-weighted AVDD1=AVDD2=3.3V		97		dB
		22Hz to 20kHz AVDD1=AVDD2=3.3V		95.5		dB
Total Harmonic Distortion <sup>4</sup>	THD	P <sub>o</sub> = 20mW, RL=16Ω		-79	-70	dBFS
Total Harmonic Distortion + Noise <sup>5</sup>	THD+N	P <sub>o</sub> = 20mW, RL=16Ω		-75	TBC	dBFS
Channel Separation <sup>6</sup>		1kHz signal		100		dB
<b>DAC to left and right mixer into headphone 16Ω load on LOUT2 and ROUT2, Class D mode, L<sub>filter</sub> = 33nH C<sub>filter</sub> = 220nf</b> <b>LOUT2VOL, ROUT2VOL, DACLVOL and DACRVOL = 0dB</b>						
Full-scale output				AVDD1/3.3		V <sub>rms</sub>
Signal to Noise Ratio <sup>3</sup>	SNR	A-weighted AVDD1=AVDD2=3.3V	80	90		dB
Total Harmonic Distortion <sup>4</sup>	THD	P <sub>o</sub> = 20mW, RL=16Ω		-79		dBFS
Channel Separation <sup>6</sup>		1kHz signal		100		dB
PWM Rise Time				1.5		ns
PWM Fall Time				1.5		ns
PWM Switching Frequency		DCLKDIV = 1000		1.4		MHz
Efficiency		R <sub>L</sub> = 16Ω, t <sub>PW</sub> = 20ns, P <sub>O</sub> = 20mW		72		%
Power Supply Rejection	PSRR	100mV <sub>pp</sub> ripple @217Hz injected on AVDD2		70		dB
Idle Current		No analogue output signal on either channel		0.5		mA
<b>Bypass paths to left and right output mixers. BYPL2LMIX = 1 and BYPR2RMIX = 1</b>						
PGA gain range into mixer		Gain adjusted by BYPLMIXVOL and BYPRMIXVOL	-15	0	+6	dB
BYPLMIXVOL and BYPRMIXVOL gain step into mixer				3		dB
Mute attenuation		BYPL2LMIX = 0 BYPR2RMIX = 0		100		dB
<b>Analogue outputs (LOUT1, ROUT1, LOUT2, ROUT2)</b>						
Programmable Gain range		Gain adjusted by L/ROUT1VOL and L/ROUT2VOL	-57	0	+6	dB
Programmable Gain step size		Monotonic		1		dB
Mute attenuation		1kHz, full scale signal L/ROUT1MUTE = 1 L/ROUT2MUTE = 1		85		dB

**Test Conditions**DCVDD=1.8V, AVDD1=AVDD2=DBVDD=3.3V, T<sub>A</sub> = +25°C, 1kHz signal, fs = 48kHz, 24-bit audio data unless otherwise stated.

PARAMETER	SYMBOL	TEST CONDITIONS	MIN	TYP	MAX	UNIT
<b>LIN and RIN input PGA to input boost stage into 10kΩ / 50pF load on OUT3/OUT4 outputs</b>						
<b>INPPGAVOLL, INPPGAVOLR, PGABOOSTL and PGABOOSTR = 0dB</b>						
Full-scale output voltage, 0dB gain				AVDD2/3.3		V <sub>rms</sub>
Signal to Noise Ratio <sup>3</sup>	SNR	A-weighted AVDD1=AVDD2=3.3V	90	98		dB
		A-weighted AVDD1=AVDD2=2.5V		96		dB
		22Hz to 22kHz AVDD1=AVDD2=3.3V		95.5		dB
		22Hz to 22kHz AVDD1=AVDD2=2.5V		93.5		dB
Total Harmonic Distortion <sup>4</sup>	THD	full-scale signal AVDD1=AVDD2=3.3V		-84		dBFS
		full-scale signal AVDD1=AVDD2=2.5V		-82		dBFS
Total Harmonic Distortion + Noise <sup>5</sup>	THD+N	full-scale signal AVDD1=AVDD2=3.3V		-82		dBFS
		full-scale signal AVDD1=AVDD2=2.5V		-80		dBFS
Channel Separation <sup>6</sup>				100		dB
<b>LIN and RIN into input PGA Bypass to LOUT1 and ROUT1 into 10kΩ / 50pF loads</b>						
<b>BYPLMIXVOL, BYPRMIXVOL, LOU1VOL and ROU1VOL = 0dB</b>						
Full-scale output voltage, 0dB gain				AVDD1/3.3		V <sub>rms</sub>
Signal to Noise Ratio <sup>3</sup>	SNR	A-weighted AVDD1=AVDD2=3.3V	90	100		dB
		A-weighted AVDD1=AVDD2=2.5V		96		dB
		22Hz to 22kHz AVDD1=AVDD2=3.3V		95.5		dB
		22Hz to 22kHz AVDD1=AVDD2=2.5V		93.5		dB
Total Harmonic Distortion <sup>4</sup>	THD	full-scale signal AVDD1=AVDD2=3.3V		-87	-75	dBFS
		full-scale signal AVDD1=AVDD2=2.5V		-69		dBFS
Total Harmonic Distortion + Noise <sup>5</sup>	THD+N	full-scale signal AVDD1=AVDD2=3.3V		-85	-73	dBFS
		full-scale signal AVDD1=AVDD2=2.5V		-68		dBFS
Channel separation <sup>6</sup>		1kHz full scale signal		100		dB
<b>Microphone Bias</b>						
Bias Voltage		MBVSEL=0		0.9*AVDD1		V
		MBVSEL=1		0.65*AVDD1		V
Bias Current Source		for V <sub>MICBIAS</sub> within +/-3%			3	Ma
Output Noise Voltage		1kHz to 20kHz		15		nV/√Hz

**Test Conditions**

DCVDD=1.8V, AVDD1=AVDD2=DBVDD=3.3V,  $T_A = +25^{\circ}\text{C}$ , 1kHz signal,  $f_s = 48\text{kHz}$ , 24-bit audio data unless otherwise stated.

PARAMETER	SYMBOL	TEST CONDITIONS	MIN	TYP	MAX	UNIT
<b>Digital Input / Output</b>						
Input HIGH Level	$V_{IH}$		$0.7 \times \text{DBVDD}$			V
Input LOW Level	$V_{IL}$				$0.3 \times \text{DBVDD}$	V
Output HIGH Level	$V_{OH}$	$I_{OL}=1\text{mA}$	$0.9 \times \text{DBVDD}$			V
Output LOW Level	$V_{OL}$	$I_{OH}=1\text{mA}$			$0.1 \times \text{DBVDD}$	V
Input Capacitance		All digital pins		10		pF
Input leakage				TBD		pA

**TERMINOLOGY**

1. Full-scale input and output levels scale in relation to AVDD or AVDD2 depending upon the input or output used. For example, when AVDD = 3.3V, 0dBFS =  $1V_{\text{rms}}$  (0dBV). When AVDD < 3.3V the absolute level of 0dBFS will decrease with a linear relationship to AVDD.
2. Input level to RIP and LIP in differential configurations is limited to a maximum of -3dB or performance will be reduced.
3. Signal-to-noise ratio (dBFS) – SNR is the difference in level between a reference full scale output signal and the device output with no signal applied. This ratio is also called idle channel noise. (No Auto-zero or Automute function is employed in achieving these results).
4. Total Harmonic Distortion (dBFS) – THD is the difference in level between a reference full scale output signal and the first seven odd harmonics of the output signal. To calculate the ratio, the fundamental frequency of the output signal is notched out and an RMS value of the next seven harmonics is calculated.
5. Total Harmonic Distortion plus Noise (dBFS) – THD+N is the difference in level between a reference full scale output signal and the sum of the harmonics, wide-band noise and interference on the output signal. To calculate the ratio, the fundamental frequency of the output signal is notched out and an RMS value of the total harmonics, wide-band noise and interference is calculated.
6. Channel Separation (dB) – Also known as Cross-Talk. This is a measure of the amount one channel is isolated from the other. Normally measured by sending a full scale signal down one channel and measuring the other.

## POWER CONSUMPTION

Typical power consumption for various scenarios is shown below.

All measurements are made with quiescent signal.

Description	DCVDD(V)	DCVDD(mA)	DBVDD(V)	DBVDD(mA)	AVDD1(V)	AVDD1(mA)	AVDD2(V)	AVDD2(mA)	Total (mW)
Off (Default Settings)	1.8	0.0002	1.8	0	2.5	0.01	2.5	0	0.03
	1.8	0.0002	3.3	0	3	0.011	3	0	0.03
	1.8	0.0002	3.3	0	3.3	0.012	3.3	0	0.04
	3.3	0.006	3.3	0	3.3	0.011	3.3	0	0.06
	3.6	0.008	3.6	0	3.6	0.012	3.6	0	0.07
Standby mode (Lowest Power)	1.8	0.002	1.8	0	2.5	0.117	2.5	0	0.30
	1.8	0.002	3.3	0	3	0.138	3	0	0.42
	1.8	0.002	3.3	0	3.3	0.149	3.3	0	0.50
	3.3	0.006	3.3	0	3.3	0.149	3.3	0	0.51
	3.6	0.008	3.6	0	3.6	0.157	3.6	0	0.59
DAC Playback 32Ω load L/ROUT2 - Class AB Mode fs=44.1kHz	1.8	3.336	1.8	0.003	2.5	2.238	2.5	0.28	12.31
	1.8	3.336	3.3	0.0021	3	2.728	3	0.35	15.24
	3.3	7.182	3.3	0.0021	3.3	3.025	3.3	0.39	34.98
	3.6	8.098	3.6	0.025	3.6	3.325	3.6	0.44	42.80
ADC Stereo Line Record fs=44.1kHz	1.8	3.57	1.8	0.013	2.5	4.76	2.5	0	18.35
	1.8	3.57	3.3	0.013	2.7	4.967	3	0	19.88
	3.3	7.603	3.3	0.026	3	5.272	3.3	0	40.99
	3.6	8.529	3.6	0.027	3.3	5.578	3.6	0	49.21

Table 1 Power Consumption

Contact [Wolfson](#) for more information on device power consumption.

# AUDIO PATHS OVERVIEW

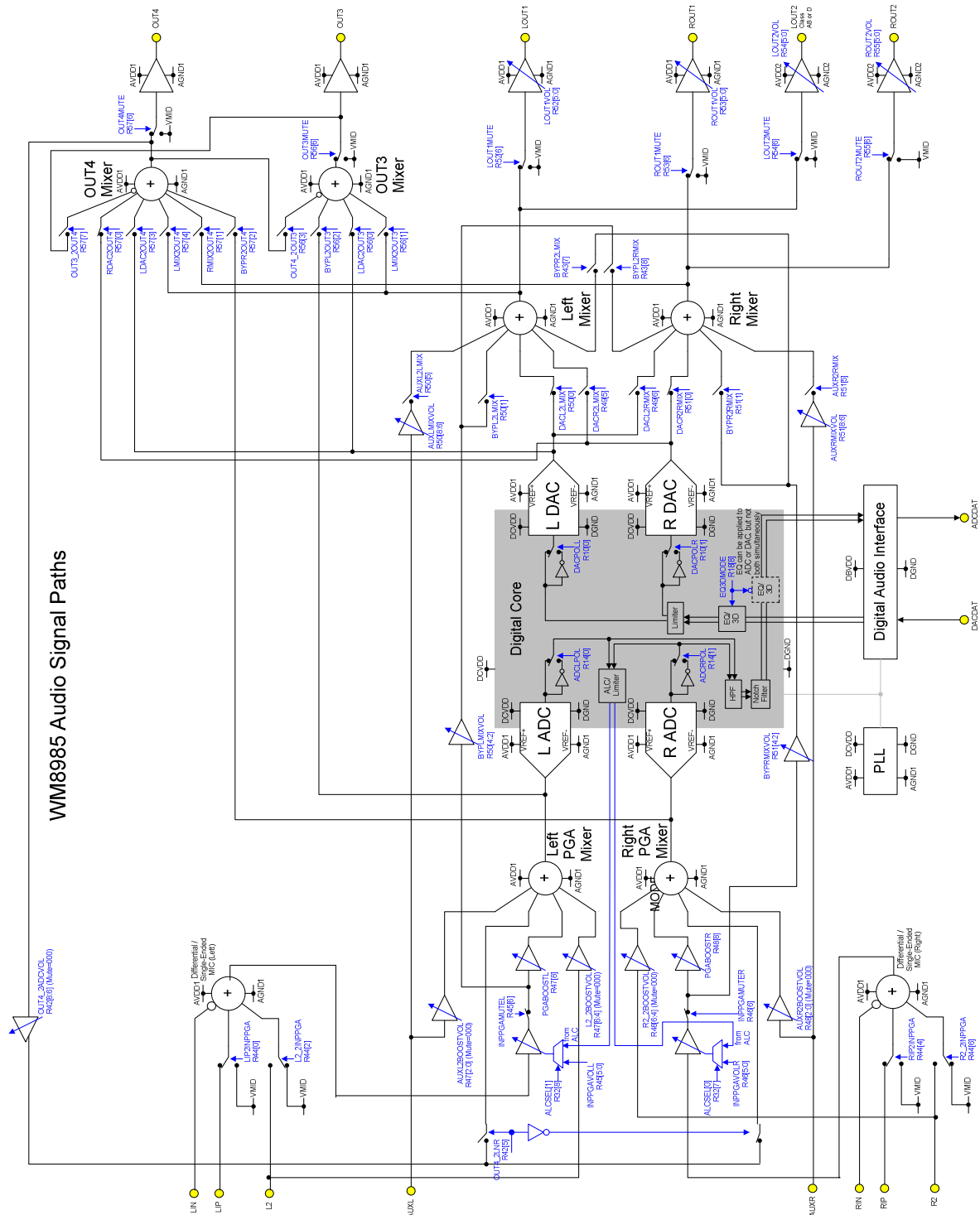


Figure 1 Audio Paths Overview

## SIGNAL TIMING REQUIREMENTS

### SYSTEM CLOCK TIMING

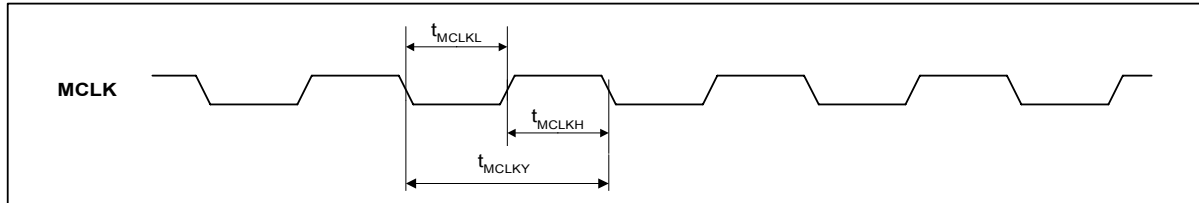


Figure 2 System Clock Timing Requirements

#### Test Conditions

DCVDD=1.8V, DBVDD=AVDD1=AVDD2=3.3V, DGND=AGND1=AGND2=0V,  $T_A = +25^\circ\text{C}$ , Slave Mode

PARAMETER	SYMBOL	CONDITIONS	MIN	TYP	MAX	UNIT
<b>System Clock Timing Information</b>						
MCLK cycle time	$T_{MCLKY}$	MCLK=SYSCLK (=256fs)	81.38			ns
		MCLK input to PLL <sup>Note 1</sup>	20			ns
MCLK duty cycle	$T_{MCLKDS}$		60:40		40:60	

#### Note:

1. PLL pre-scaling and PLL N and K values should be set appropriately so that SYSCLK is no greater than 12.288MHz.

### AUDIO INTERFACE TIMING – MASTER MODE

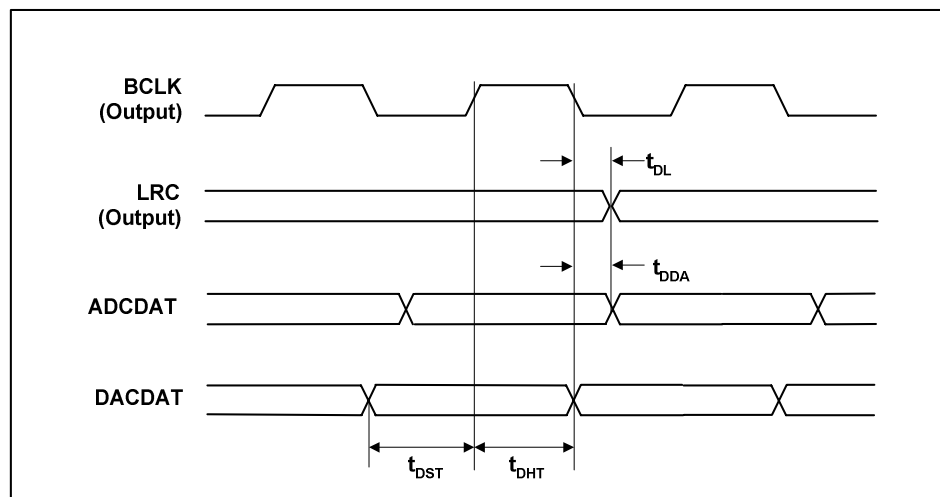


Figure 3 Digital Audio Data Timing – Master Mode (see Control Interface)

**Test Conditions**

DCVDD=1.8V, DBVDD=AVDD1=AVDD2=3.3V, DGND=AGND1=AGND2=0V,  $T_A=+25^{\circ}\text{C}$ , Master Mode,  $f_s=48\text{kHz}$ , MCLK=256fs, 24-bit data, unless otherwise stated.

PARAMETER	SYMBOL	MIN	TYP	MAX	UNIT
<b>Audio Data Input Timing Information</b>					
LRC propagation delay from BCLK falling edge	$t_{DL}$			10	ns
ADCDAT propagation delay from BCLK falling edge	$t_{DDA}$			10	ns
DACDAT setup time to BCLK rising edge	$t_{DST}$	10			ns
DACDAT hold time from BCLK rising edge	$t_{DHT}$	10			ns

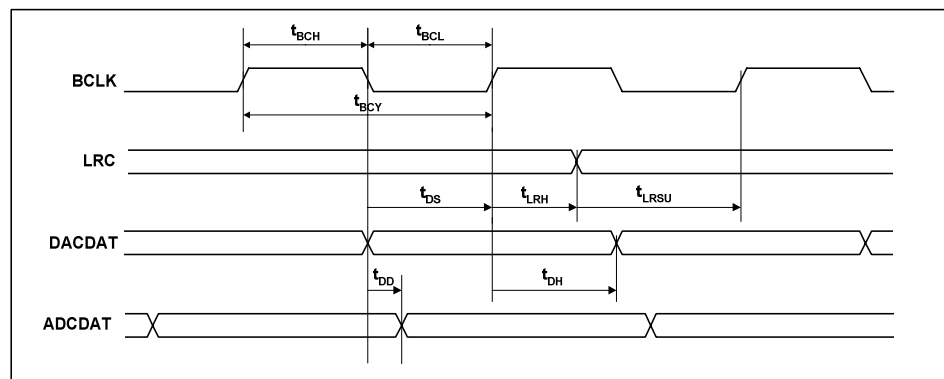
**AUDIO INTERFACE TIMING – SLAVE MODE**

Figure 4 Digital Audio Data Timing – Slave Mode

**Test Conditions**

DCVDD=1.8V, DBVDD=AVDD1=AVDD2=3.3V, DGND=AGND1=AGND2=0V,  $T_A=+25^{\circ}\text{C}$ , Slave Mode,  $f_s=48\text{kHz}$ , MCLK= 256fs, 24-bit data, unless otherwise stated.

PARAMETER	SYMBOL	MIN	TYP	MAX	UNIT
<b>Audio Data Input Timing Information</b>					
BCLK cycle time	$t_{BCY}$	50			ns
BCLK pulse width high	$t_{BCH}$	20			ns
BCLK pulse width low	$t_{BCL}$	20			ns
LRC set-up time to BCLK rising edge	$t_{LRSU}$	10			ns
LRC hold time from BCLK rising edge	$t_{LRH}$	10			ns
DACDAT hold time from BCLK rising edge	$t_{DH}$	10			ns
DACDAT set-up time to BCLK rising edge	$t_{DS}$	10			ns
ADCDAT propagation delay from BCLK falling edge	$t_{DD}$			10	ns

**Note:**

BCLK period should always be greater than or equal to MCLK period.

## CONTROL INTERFACE TIMING – 3-WIRE MODE

3-wire mode is selected by connecting the MODE pin high.

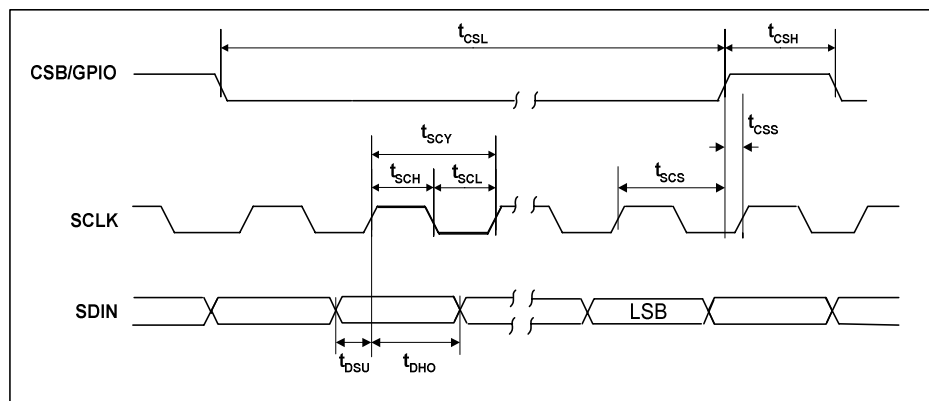


Figure 5 Control Interface Timing – 3-Wire Serial Control Mode

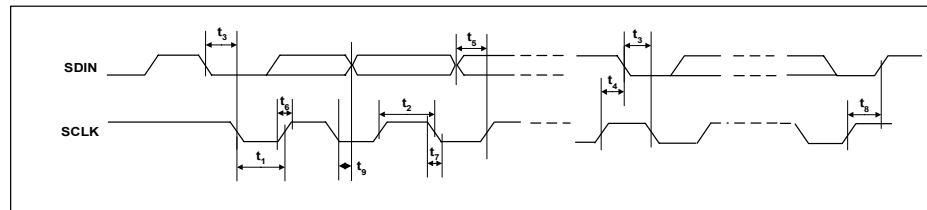
### Test Conditions

DCVDD = 1.8V, DBVDD = AVDD1 = AVDD2 = 3.3V, DGND = AGND1 = AGND2 = 0V,  $T_A = +25^\circ\text{C}$ , Slave Mode,  $f_s = 48\text{kHz}$ , MCLK = 256fs, 24-bit data, unless otherwise stated.

PARAMETER	SYMBOL	MIN	TYP	MAX	UNIT
<b>Program Register Input Information</b>					
SCLK rising edge to CSB rising edge	$t_{SCS}$	80			ns
SCLK pulse cycle time	$t_{SCY}$	200			ns
SCLK pulse width low	$t_{SCL}$	80			ns
SCLK pulse width high	$t_{SCH}$	80			ns
SDIN to SCLK set-up time	$t_{DSU}$	40			ns
SCLK to SDIN hold time	$t_{DHO}$	40			ns
CSB pulse width low	$t_{CSL}$	40			ns
CSB pulse width high	$t_{CSH}$	40			ns
CSB rising to SCLK rising	$t_{CSS}$	40			ns
Pulse width of spikes that will be suppressed	$t_{ps}$	0		5	ns

**CONTROL INTERFACE TIMING – 2-WIRE MODE**

2-wire mode is selected by connecting the MODE pin low.



**Figure 6 Control Interface Timing – 2-Wire Serial Control Mode**

**Test Conditions**

DCVDD=1.8V, DBVDD=AVDD1=AVDD2=3.3V, DGND=AGND1=AGND2=0V,  $T_A=+25^{\circ}\text{C}$ , Slave Mode,  $f_s=48\text{kHz}$ , MCLK = 256fs, 24-bit data, unless otherwise stated.

PARAMETER	SYMBOL	MIN	TYP	MAX	UNIT
<b>Program Register Input Information</b>					
SCLK Frequency		0		526	kHz
SCLK Low Pulse-Width	$t_1$	1.3			us
SCLK High Pulse-Width	$t_2$	600			ns
Hold Time (Start Condition)	$t_3$	600			ns
Setup Time (Start Condition)	$t_4$	600			ns
Data Setup Time	$t_5$	100			ns
SDIN, SCLK Rise Time	$t_6$			300	ns
SDIN, SCLK Fall Time	$t_7$			300	ns
Setup Time (Stop Condition)	$t_8$	600			ns
Data Hold Time	$t_9$			900	ns
Pulse width of spikes that will be suppressed	$t_{ps}$	0		5	ns

## INTERNAL POWER ON RESET CIRCUIT

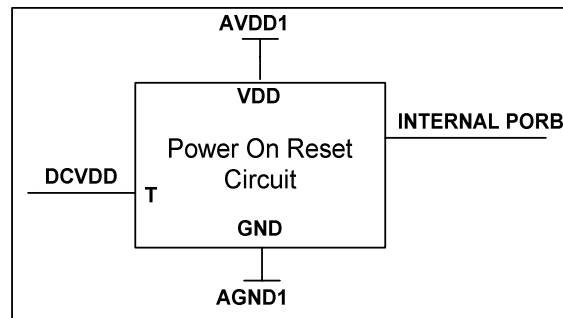


Figure 7 Internal Power on Reset Circuit Schematic

The WM8985 includes an internal Power-On-Reset Circuit, as shown in Figure 7, which is used to reset the digital logic into a default state after power up. The POR circuit is powered from AVDD1 and monitors DCVDD. It asserts PORB low if AVDD1 or DCVDD is below a minimum threshold.

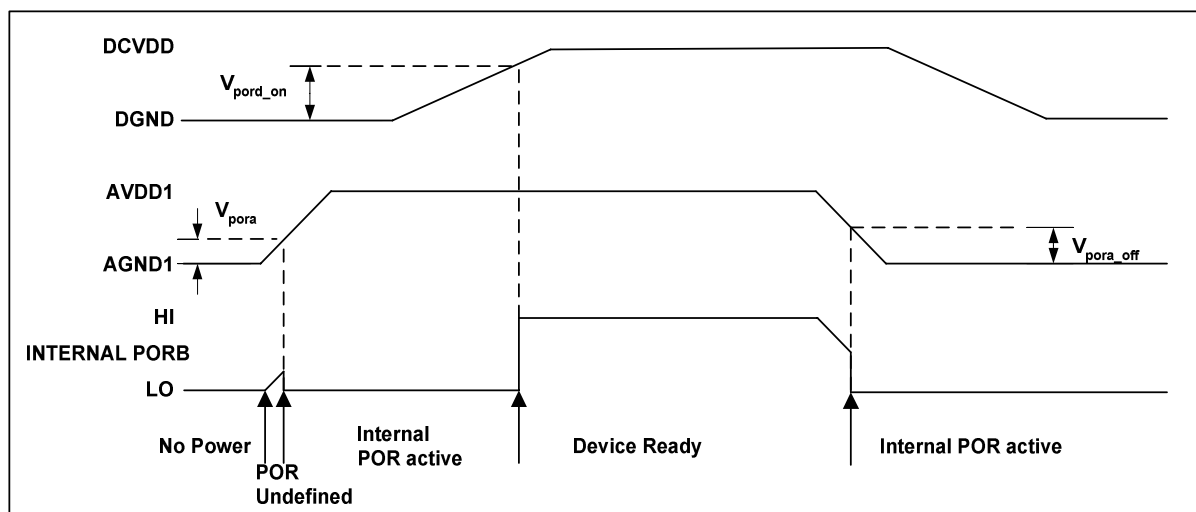


Figure 8 Typical Power up Sequence where AVDD1 is Powered before DCVDD

Figure 8 shows a typical power-up sequence where AVDD1 comes up first. When AVDD1 goes above the minimum threshold,  $V_{\text{pora}}$ , there is enough voltage for the circuit to guarantee PORB is asserted low and the chip is held in reset. In this condition, all writes to the control interface are ignored. Now AVDD1 is at full supply level. Next DCVDD rises to  $V_{\text{pord\_on}}$  and PORB is released high and all registers are in their default state and writes to the control interface may take place.

On power down, where AVDD1 falls first, PORB is asserted low whenever AVDD1 drops below the minimum threshold  $V_{\text{pora\_off}}$ .

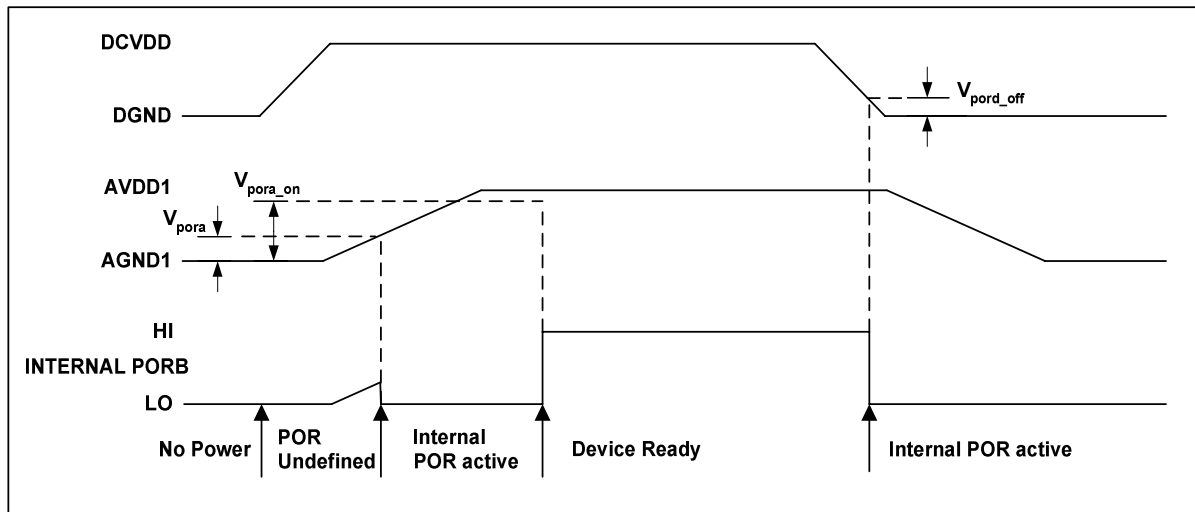


Figure 9 Typical Power up Sequence where DCVDD is Powered before AVDD1

Figure 9 shows a typical power-up sequence where DCVDD comes up first. First it is assumed that DCVDD is already up to specified operating voltage. When AVDD1 goes above the minimum threshold,  $V_{pora}$ , there is enough voltage for the circuit to guarantee PORB is asserted low and the chip is held in reset. In this condition, all writes to the control interface are ignored. When AVDD1 rises to  $V_{pora\_on}$ , PORB is released high and all registers are in their default state and writes to the control interface may take place.

On power down, where DCVDD falls first, PORB is asserted low whenever DCVDD drops below the minimum threshold  $V_{pord\_off}$ .

SYMBOL	MIN	TYP	MAX	UNIT
$V_{pora}$	0.4	0.6	0.8	V
$V_{pora\_on}$	0.9	1.2	1.6	V
$V_{pora\_off}$	0.4	0.6	0.8	V
$V_{pord\_on}$	0.5	0.7	0.9	V
$V_{pord\_off}$	0.4	0.6	0.8	V

Table 2 Typical POR Operation (Typical Simulated Values)

**Notes:**

1. If AVDD1 and DCVDD suffer a brown-out (i.e. drop below the minimum recommended operating level but do not go below  $V_{pora\_off}$  or  $V_{pord\_off}$ ) then the chip will not reset and will resume normal operation when the voltage is back to the recommended level again.
2. The chip will enter reset at power down when AVDD1 or DCVDD falls below  $V_{pora\_off}$  or  $V_{pord\_off}$ . This may be important if the supply is turned on and off frequently by a power management system.
3. The minimum  $t_{por}$  period is maintained even if DCVDD and AVDD1 have zero rise time. This specification is guaranteed by design rather than test.

## RECOMMENDED POWER UP/DOWN SEQUENCE

In order to minimise output pop and click noise, it is recommended that the WM8985 device is powered up and down under control using the following sequences:

### Power Up:

1. Turn on external power supplies. Wait for supply voltage to settle.
2. Set low analogue bias mode, BIASCUT = 1
3. Enable thermal shutdown TSDEN = TSOPCTRL = 1
4. Enable Internal bias BIASEN = 1.
5. Mute all outputs and set PGAs to minimum gain, R52 to R57 = 0x140h.
6. Enable VMID independent current bias, POBCTRL = 1.
7. Enable required outputs, DACs and mixers.
8. Enable VMID with required charge time e.g. VMIDSEL=01.
9. Wait 10ms (based on register updates of 325µs)
10. Setup digital interface, input amplifiers, PLL, ADCs and DACs for desired operation.
11. Disable VMID independent current bias, POBCTRL = 0.
12. Wait 500ms <sup>1</sup>
13. Unmute L/ROUT1 and set desired volume, e.g. for 0dB R52 and R53 = 0x139h.
14. Unmute L/ROUT2 and set desired volume, e.g. for 0dB R54 and R55 = 0x139h.

### Power Down <sup>2</sup>:

1. Disable Thermal shutdown, TSDEN = TSOPCTRL = 0
2. Disable VMIDSEL=00 and BIASEN=0
3. Wait for VMID to discharge <sup>3</sup>
4. Power off registers R1, R2, R3 = 0x000h
5. Remove external power supplies

### Notes:

1. Charging time constant is determined by impedance selected by VMIDSEL and the value of decoupling capacitor connected to VMID pin.
2. It is possible to interrupt the power down sequence and power up to VMID before the allocated VMID discharge time. This is done by following the power-up sequence omitting steps 4 to 8.
3. Discharge time constant is determined by the values of analogue output capacitors.

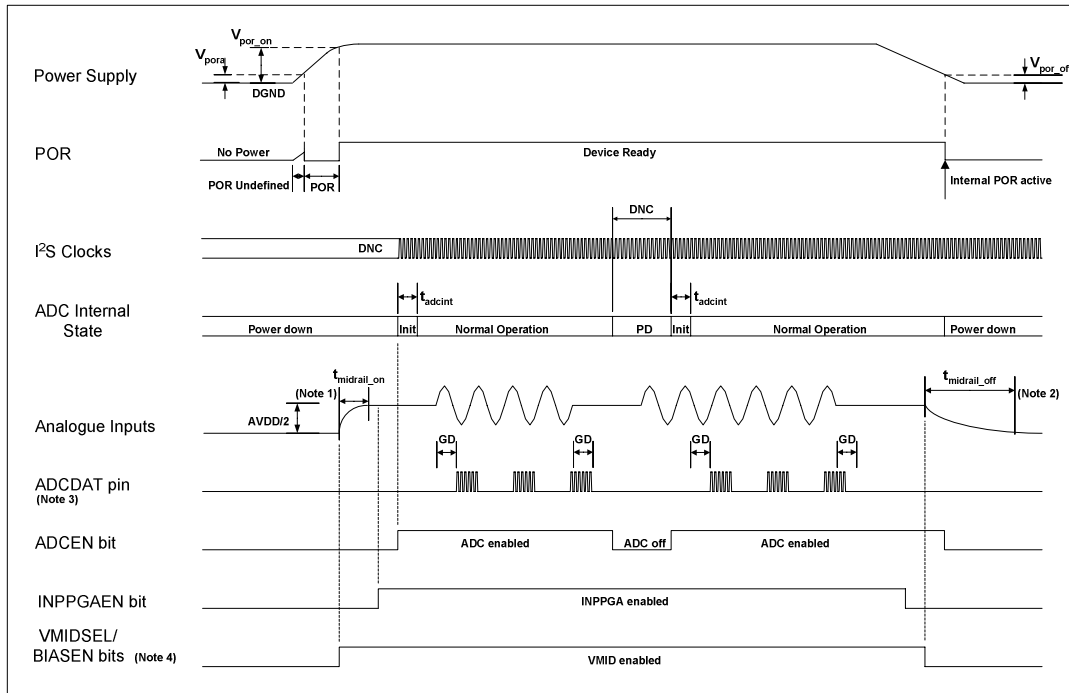


Figure 10 ADC Power Up and Down Sequence (not to scale)

SYMBOL	MIN	TYPICAL	MAX	UNIT
$t_{midrail\_on}$		300		ms
$t_{midrail\_off}$		>6		s
$t_{adcint}$		2/fs		n/fs
ADC Group Delay		29/fs		n/fs

Table 3 Typical POR Operation (Typical Simulated Values)

**Notes:**

1. The analogue input pin charge time,  $t_{\text{midrail\_on}}$ , is determined by the VMID pin charge time. This time is dependent upon the value of VMID decoupling capacitor and VMID pin input resistance and AVDD1 power supply rise time.
2. The analogue input pin discharge time,  $t_{\text{midrail\_off}}$ , is determined by the analogue input coupling capacitor discharge time. The time,  $t_{\text{midrail\_off}}$ , is measured using a  $1\mu\text{F}$  capacitor on the analogue input but will vary dependent upon the value of input coupling capacitor.
3. While the ADC is enabled there will be LSB data bit activity on the ADCDAT pin due to system noise but no significant digital output will be present.
4. The VMIDSEL and BIASEN bits must be set to enable analogue input midrail voltage and for normal ADC operation.
5. ADCDAT data output delay from power up - with power supplies starting from 0V - is determined primarily by the VMID charge time. ADC initialisation and power management bits may be set immediately after POR is released; VMID charge time will be significantly longer and will dictate when the device is stabilised for analogue input.
6. ADCDAT data output delay at power up from device standby (power supplies already applied) is determined by ADC initialisation time,  $2/f_s$ .

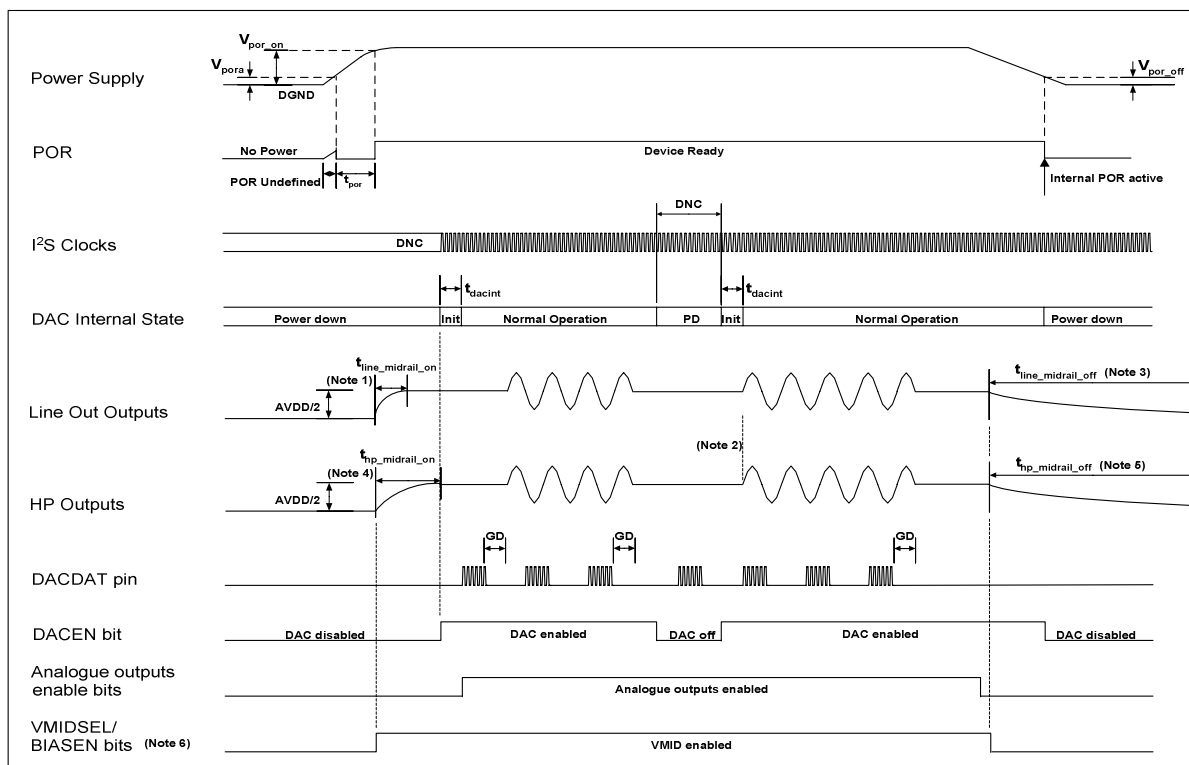


Figure 11 DAC Power Up and Down Sequence (not to scale)

SYMBOL	MIN	TYPICAL	MAX	UNIT
$t_{line\_midrail\_on}$		300		ms
$t_{line\_midrail\_off}$		>6		s
$t_{hp\_midrail\_on}$		300		ms
$t_{hp\_midrail\_off}$		>6		s
$t_{dacint}$		2/fs		n/fs
DAC Group Delay		29/fs		n/fs

**Table 4 Typical POR Operation (Typical Simulated Values)**

**Notes:**

1. The lineout charge time,  $t_{line\_midrail\_on}$ , is determined by the VMID pin charge time. This time is dependent upon the value of VMID decoupling capacitor and VMID pin input resistance and AVDD1 power supply rise time. The values above were measured using a 4.7 $\mu$ F capacitor.
2. It is not advisable to allow DACDAT data input during initialisation of the DAC. If the DAC data value is not zero at point of initialisation, then this is likely to cause a pop noise on the analogue outputs. The same is also true if the DACDAT is removed at a non-zero value, and no mute function has been applied to the signal beforehand.
3. The lineout discharge time,  $t_{line\_midrail\_off}$ , is determined by the VMID pin discharge time. This time is dependent upon the value of VMID decoupling capacitor and VMID pin input resistance. The values above were measured using a 4.7 $\mu$ F capacitor.
4. The headphone charge time,  $t_{hp\_midrail\_on}$ , is dependent upon the value of VMID decoupling capacitor and VMID pin input resistance and AVDD1 power supply rise time. The values above were measured using a 4.7 $\mu$ F VMID decoupling capacitor.
5. The headphone discharge time,  $t_{hp\_midrail\_off}$ , is dependent upon the value of VMID decoupling capacitor and VMID pin input resistance. The values above were measured using a 4.7 $\mu$ F VMID decoupling capacitor.
6. The VMIDSEL and BIASEN bits must be set to enable analogue output midrail voltage and for normal DAC operation.

## DEVICE DESCRIPTION

### INTRODUCTION

The WM8985 is a low power audio codec combining a high quality stereo audio DAC and ADC, with flexible line and microphone input and output processing.

#### FEATURES

The chip offers great flexibility in use, and so can support many different modes of operation as follows:

#### MICROPHONE INPUTS

Two pairs of stereo microphone inputs are provided, allowing a pair of stereo microphones to be pseudo-differentially connected, with user defined gain. The provision of the common mode input pin for each stereo input allows for rejection of common mode noise on the microphone inputs (level depends on gain setting chosen). A microphone bias is output from the chip which can be used to bias both microphones. The signal routing can be configured to allow manual adjustment of mic levels, or to allow the ALC loop to control the level of mic signal that is transmitted.

Total gain through the microphone paths of up to +55.25dB can be selected.

#### PGA AND ALC OPERATION

A programmable gain amplifier is provided in the input path to the ADC. This may be used manually or in conjunction with a mixed analogue/digital automatic level control (ALC) which keeps the recording volume constant.

#### AUXILIARY ANALOG LINE INPUTS (AUXL, AUXR)

The inputs, AUXL and AUXR, can be used as a stereo line input or as an input for warning tones (or 'beeps') etc. These inputs can be summed into the record paths, along with the microphone preamp outputs, so allowing for mixing of audio with 'backing music' etc as required.

Additional stereo analog signals might be connected to the Line inputs of WM8985 (e.g. melody chip or FM radio), and the stereo signal listened to via headphones, or recorded, simultaneously if required.

#### ADC

The stereo ADC uses a 24-bit high-order over sampling architecture to deliver optimum performance with low power consumption.

#### HI-FI DAC

The hi-fi DAC provides high quality audio playback suitable for all portable audio hi-fi type applications, including MP3 players and portable disc players of all types.

#### OUTPUT MIXERS

Flexible mixing is provided on the outputs of the device. A stereo mixer is provided for the stereo headphone or line outputs, LOUT1/ROUT1, and additional summers on the OUT3/OUT4 outputs allow for an optional differential or stereo line output on these pins. Gain adjustment PGAs are provided for the LOUT1/ROUT1 and LOUT2/ROUT2 outputs, and signal switching is provided to allow for all possible signal combinations.

OUT3 and OUT4 can be configured to provide an additional stereo or mono differential lineout from the output of the DACs, the mixers or the input microphone boost stages. They can also provide a midrail reference for pseudo differential inputs to external amplifiers.

### AUDIO INTERFACES

The WM8985 has a standard audio interface, to support the transmission of stereo data to and from the chip. This interface is a 3 wire standard audio interface which supports a number of audio data formats including:

- I<sup>2</sup>S
- DSP/PCM Mode (a burst mode in which LRC sync plus 2 data packed words are transmitted)
- MSB-First, left justified
- MSB-First, right justified

The interface can operate in master or slave modes.

### CONTROL INTERFACES

To allow full software control over all features, the WM8985 offers a choice of 2 or 3 wire control interface. It is fully compatible and an ideal partner for a wide range of industry standard microprocessors, controllers and DSPs.

Selection of the mode is via the MODE pin. In 2 wire mode, the address of the device is fixed as 0011010.

### CLOCKING SCHEMES

WM8985 offers the normal audio DAC clocking scheme operation, where 256fs MCLK is provided to the DAC and ADC. A flexible clock divider allows the 256fs DAC clock to be generated from a range of input clock frequencies, for example, 256fs, 384fs, 512fs and 768fs.

A PLL is included which may be used to generate these clocks in the event that they are not available from the system controller. This PLL can accept a range of common input clock frequencies between 8MHz and 50MHz to generate high quality audio clocks. If this PLL is not required for generation of these clocks, it can be reconfigured to generate alternative clocks which may then be output on the GPIO1 pin and used elsewhere in the system; available in 2-wire control mode only.

### POWER CONTROL

The design of the WM8985 has given much attention to power consumption without compromising performance. The WM8985 operates at low analog and digital supply voltages, and includes the ability to power off any unused parts of the circuitry under software control. It also includes standby and power off modes.

## INPUT SIGNAL PATH

The WM8985 has a number of flexible analogue inputs. There are two input channels, Left and Right, each of which consists of an input PGA stage followed by a boost/mix stage which drives into the hi-fi ADC. Each input path has three input pins which can be configured in a variety of ways to accommodate single-ended, pseudo-differential or dual differential microphones. There are two auxiliary input pins which can be fed into the input boost/mix stage as well as driving into the output path. A bypass path exists from the output of the boost/mix stage into the output left/right mixers.

### MICROPHONE INPUTS

The WM8985 can accommodate a variety of microphone configurations including single ended and pseudo-differential inputs. The inputs to the left differential input PGA are LIN, LIP and L2. The inputs to the right differential input PGA are RIN, RIP and R2.

In single-ended microphone input configuration the microphone signal should be input to LIN or RIN and the non-inverting input of the input PGA clamped to VMID.

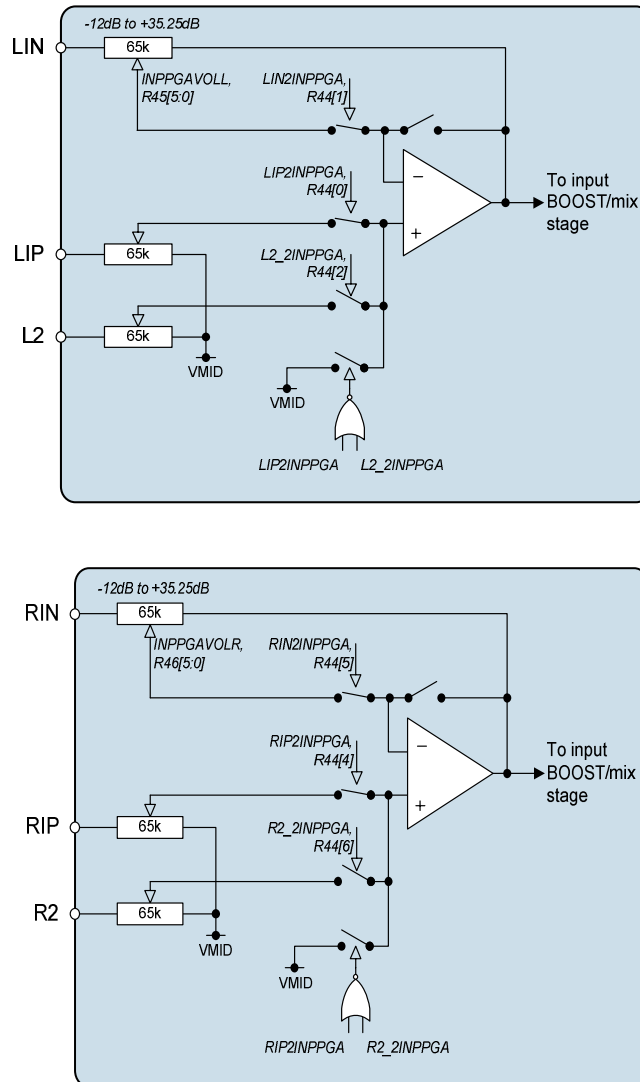


Figure 12 Microphone Input PGA Circuit

The input PGAs are enabled by the INPPGAENL and INPPGAENR register bits.

REGISTER ADDRESS	BIT	LABEL	DEFAULT	DESCRIPTION
R2 (02h) Power Management 2	2	INPPGAENL	0	Left channel input PGA enable 0 = disabled 1 = enabled
	3	INPPGAENR	0	Right channel input PGA enable 0 = disabled 1 = enabled

Table 5 Input PGA Enable Register Settings

REGISTER ADDRESS	BIT	LABEL	DEFAULT	DESCRIPTION
R44 (2Ch) Input Control	0	LIP2INPPGA	1	Connect LIP pin to left channel input PGA amplifier positive terminal. 0 = LIP not connected to input PGA 1 = input PGA amplifier positive terminal connected to LIP (constant input impedance)
	1	LIN2INPPGA	1	Connect LIN pin to left channel input PGA negative terminal. 0 = LIN not connected to input PGA 1 = LIN connected to input PGA amplifier negative terminal.
	2	L2_2INPPGA	0	Connect L2 pin to left channel input PGA positive terminal. 0 = L2 not connected to input PGA 1 = L2 connected to input PGA amplifier positive terminal (constant input impedance).
	4	RIP2INPPGA	1	Connect RIP pin to right channel input PGA amplifier positive terminal. 0 = RIP not connected to input PGA 1 = right channel input PGA amplifier positive terminal connected to RIP (constant input impedance)
	5	RIN2INPPGA	1	Connect RIN pin to right channel input PGA negative terminal. 0 = RIN not connected to input PGA 1 = RIN connected to right channel input PGA amplifier negative terminal.
	6	R2_2INPPGA	0	Connect R2 pin to right channel input PGA positive terminal. 0 = R2 not connected to input PGA 1 = R2 connected to input PGA amplifier positive terminal (constant input impedance).

Table 6 Input PGA Control

### INPUT PGA VOLUME CONTROLS

The input microphone PGAs have a gain range from -12dB to +35.25dB in 0.75dB steps. The gain from the LIN/RIN input to the PGA output and from the L2/R2 amplifier to the PGA output are always common and controlled by the register bits INPPGAVOLL[5:0] and INPPGAVOLR[5:0]. These register bits also affect the LIP pin when LIP2INPPGA=1, the L2 pin when L2\_2INPPGA=1, the RIP pin when RIP2INPPGA=1 and the R2 pin when R2\_2INPPGA=1.

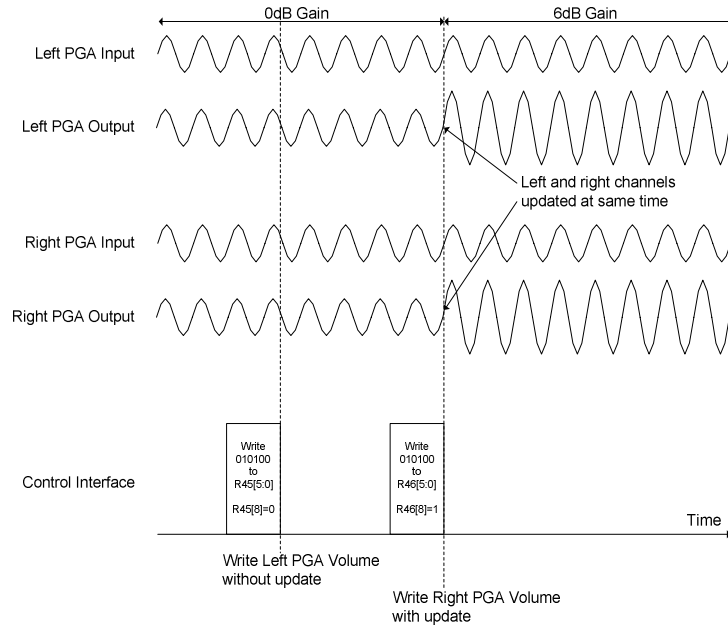
When the Automatic Level Control (ALC) is enabled the input PGA gains are controlled automatically and the INPPGAVOLL and INPPGAVOLR bits should not be used.

REGISTER ADDRESS	BIT	LABEL	DEFAULT	DESCRIPTION
R45 (20h) Left channel input PGA volume control	5:0	INPPGAVOLL	010000 (0dB)	Left channel input PGA volume 000000 = -12dB 000001 = -11.25db . 010000 = 0dB . 111111 = +35.25dB
	6	INPPGAMUTEL	0	Mute control for left channel input PGA: 0 = Input PGA not muted, normal operation 1 = Input PGA muted (and disconnected from the following input BOOST stage).
	7	INPPGAZCL	0	Left channel input PGA zero cross enable: 0 = Update gain when gain register changes 1 = Update gain on 1 <sup>st</sup> zero cross after gain register write.
	8	INPPGAVU	Not latched	INPPGA left and INPPGA right volume do not update until a 1 is written to INPPGAVU (in reg 45 or 46) (See "Volume Updates" below)
R46 (2Eh) Right channel input PGA volume control	5:0	INPPGAVOLR	010000 (0dB)	Right channel input PGA volume 000000 = -12dB 000001 = -11.25db . 010000 = 0dB . 111111 = +35.25dB
	6	INPPGAMUTER	0	Mute control for right channel input PGA: 0 = Input PGA not muted, normal operation 1 = Input PGA muted (and disconnected from the following input BOOST stage).
	7	INPPGAZCR	0	Right channel input PGA zero cross enable: 0 = Update gain when gain register changes 1 = Update gain on 1 <sup>st</sup> zero cross after gain register write.
	8	INPPGAVU	Not latched	INPPGA left and INPPGA right volume do not update until a 1 is written to INPPGAVU (in reg 45 or 46) (See "Volume Updates" below)
R32 (20h) ALC control 1	8:7	ALCSEL	00	ALC function select: 00 = ALC off 01 = ALC right only 10 = ALC left only 11 = ALC both on

Table 7 Input PGA Volume Control

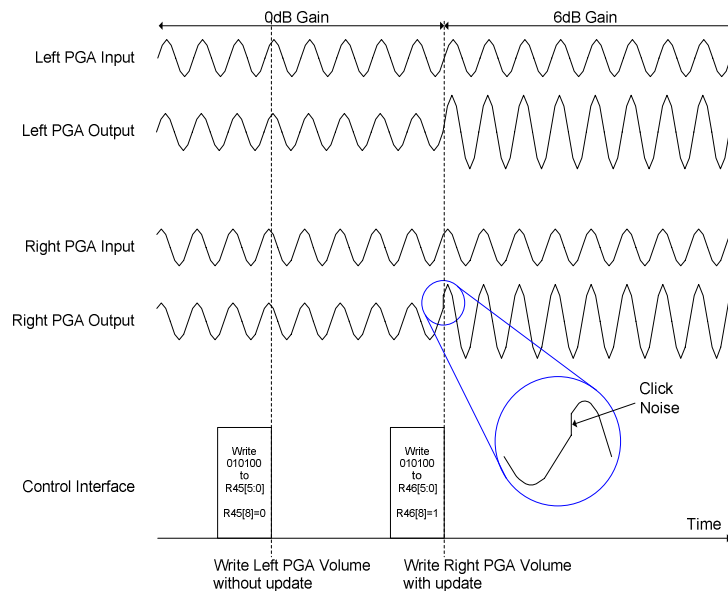
**VOLUME UPDATES**

Volume settings will not be applied to the PGAs until a '1' is written to one of the INPPGAVU bits. This is to allow left and right channels to be updated at the same time, as shown in Figure 13.



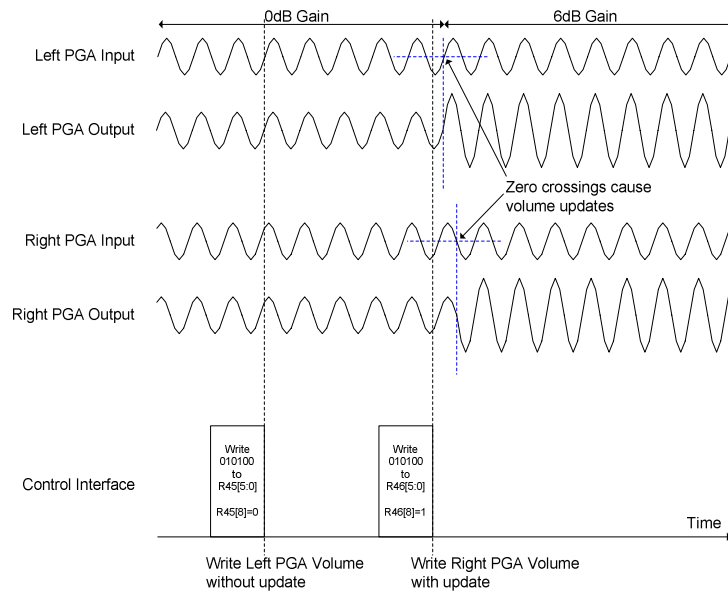
**Figure 13 Simultaneous Left and Right Volume Updates**

If the volume is adjusted while the signal is a non-zero value, an audible click can occur as shown in Figure 14.



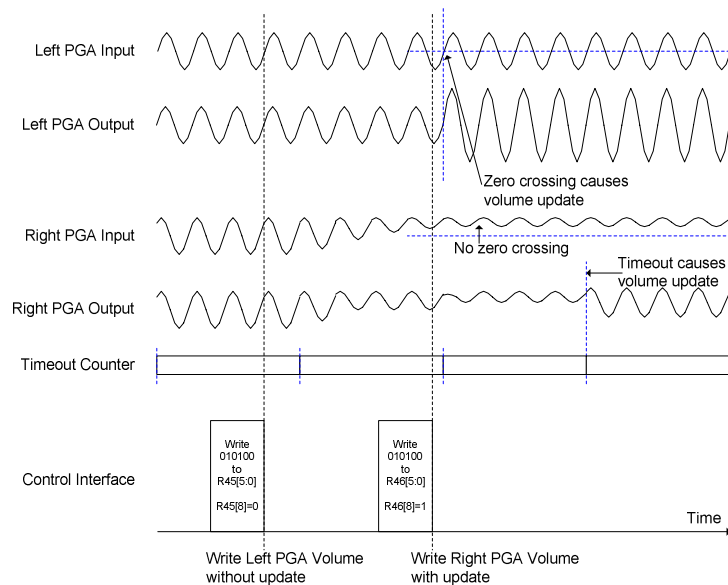
**Figure 14 Click Noise During Volume Update**

In order to prevent this click noise, a zero cross function is provided. When enabled, this will cause the PGA volume to update only when a zero crossing occurs, minimising click noise as shown in Figure 15.



**Figure 15 Volume Update Using Zero Cross Detection**

If there is a long period where no zero-crossing occurs, a timeout circuit in the WM8985 will automatically update the volume. The volume updates will occur between one and two timeout periods, depending on when the INPPGAVU bit is set as shown in Figure 16.



**Figure 16 Volume Update After Timeout**

## AUXILIARY INPUTS

There are two auxiliary inputs, AUXL and AUXR which can be used for a variety of purposes such as stereo line inputs or as a 'beep' input signal to be mixed with the outputs.

The AUXL/R inputs can be used as a line input to the input BOOST stage which has adjustable gain of -12dB to +6dB in 3dB steps, with an additional "off" state (i.e. not connected to ADC input). See the INPUT BOOST section for further details.

The AUXL/R inputs can also be mixed into the output channel mixers, with a gain of -15dB to +6dB plus off.

## INPUT BOOST

Each of the stereo input PGA stages is followed by an input BOOST circuit. The input BOOST circuit has 3 selectable inputs: the input microphone PGA output, the AUX amplifier output and the L2/R2 input pin (can be used as a line input, bypassing the input PGA). These three inputs can be mixed together and have individual gain boost/adjust as shown in Figure 17.

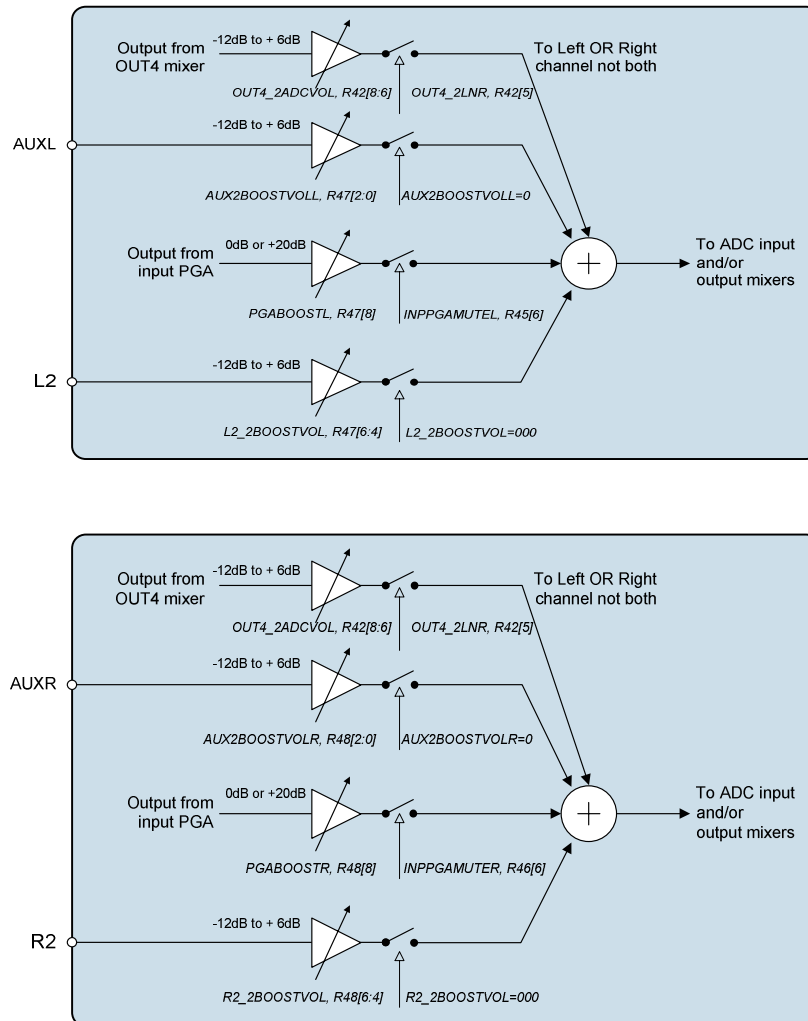


Figure 17 Input Boost Stage

The input PGA paths can have a +20dB boost (PGABOOSTL/R=1), a 0dB pass through (PGABOOSTL/R=0) or be completely isolated from the input boost circuit (INPPGAMUTEL/R=1).

REGISTER ADDRESS	BIT	LABEL	DEFAULT	DESCRIPTION
R47 (2Fh) Left Input BOOST control	8	PGABOOSTL	1	Boost enable for left channel input PGA: 0 = PGA output has +0dB gain through input BOOST stage. 1 = PGA output has +20dB gain through input BOOST stage.
R48 (30h) Right Input BOOST control	8	PGABOOSTR	1	Boost enable for right channel input PGA: 0 = PGA output has +0dB gain through input BOOST stage. 1 = PGA output has +20dB gain through input BOOST stage.

**Table 8 Input BOOST Stage Control**

The Auxiliary amplifier path to the BOOST stages is controlled by the AUXL2BOOSTVOL[2:0] and AUXR2BOOSTVOL[2:0] register bits. When AUXL2BOOSTVOL/AUXR2BOOSTVOL=000 this path is completely disconnected from the BOOST stage. Settings 001 through to 111 control the gain in 3dB steps from -12dB to +6dB.

The L2/R2 path to the BOOST stage is controlled by the LIP2BOOSTVOL[2:0] and the RIP2BOOSTVOL[2:0] register bits. When L2\_2BOOSTVOL[6:4] and R2\_2BOOSTVOL[6:4]=000 the L2/R2 input pin is completely disconnected from the BOOST stage. Settings 001 through to 111 control the gain in 3dB steps from -12dB to +6dB.

REGISTER ADDRESS	BIT	LABEL	DEFAULT	DESCRIPTION
R42 (2Ah) OUT4 to ADC	8:6	OUT4_2ADCVOL	000	Controls the OUT4 to ADC input boost stage: 000 = Path disabled (disconnected) 001 = -12dB gain 010 = -9dB gain 011 = -6dB gain 100 = -3dB gain 101 = +0dB gain 110 = +3dB gain 111 = +6dB gain
	5	OUT4_2LNR	0	OUT4 to L or R ADC input 0 = Right ADC input 1 = Left ADC input
R47 (2Fh) Left channel Input BOOST control	2:0	AUXL2BOOSTVOL	000	Controls the auxiliary amplifier to the left channel input boost stage: 000 = Path disabled (disconnected) 001 = -12dB gain 010 = -9dB gain 011 = -6dB gain 100 = -3dB gain 101 = +0dB gain 110 = +3dB gain 111 = +6dB gain
	6:4	L2_2BOOSTVOL	000	Controls the L2 pin to the left channel input boost stage: 000 = Path disabled (disconnected) 001 = -12dB gain 010 = -9dB gain 011 = -6dB gain 100 = -3dB gain 101 = +0dB gain 110 = +3dB gain 111 = +6dB gain
R48 (30h) Right channel Input BOOST control	2:0	AUXR2BOOSTVOL	000	Controls the auxiliary amplifier to the right channel input boost stage: 000 = Path disabled (disconnected) 001 = -12dB gain 010 = -9dB gain 011 = -6dB gain 100 = -3dB gain 101 = +0dB gain 110 = +3dB gain 111 = +6dB gain

REGISTER ADDRESS	BIT	LABEL	DEFAULT	DESCRIPTION
	6:4	R2_2BOOSTVOL	000	Controls the R2 pin to the right channel input boost stage: 000 = Path disabled (disconnected) 001 = -12dB 010 = -9dB gain 011 = -6dB gain 100 = -3dB gain 101 = +0dB gain 110 = +3dB gain 111 = +6dB gain

Table 9 Input BOOST Stage Control

The BOOST stage is enabled under control of the BOOSTEN register bit.

REGISTER ADDRESS	BIT	LABEL	DEFAULT	DESCRIPTION
R2 (02h) Power management 2	4	BOOSTENL	0	Left channel Input BOOST enable 0 = Boost stage OFF 1 = Boost stage ON
	5	BOOSTENR	0	Right channel Input BOOST enable 0 = Boost stage OFF 1 = Boost stage ON

Table 10 Input BOOST Enable Control

### MICROPHONE BIASING CIRCUIT

The MICBIAS output provides a low noise reference voltage suitable for biasing electret type microphones and the associated external resistor biasing network. Refer to the Applications Information section for recommended external components. The MICBIAS voltage can be altered via the MBVSEL register bit. When MBVSEL=0, MICBIAS=0.9\*AVDD1 and when MBVSEL=1, MICBIAS=0.65\*AVDD1. The output can be enabled or disabled using the MICBEN control bit.

REGISTER ADDRESS	BIT	LABEL	DEFAULT	DESCRIPTION
R1 (01h) Power management 1	4	MICBEN	0	Microphone Bias Enable 0 = OFF (high impedance output) 1 = ON

Table 11 Microphone Bias Enable Control

REGISTER ADDRESS	BIT	LABEL	DEFAULT	DESCRIPTION
R44 (2Ch) Input control	8	MBVSEL	0	Microphone Bias Voltage Control 0 = 0.9 * AVDD1 1 = 0.65 * AVDD1

Table 12 Microphone Bias Voltage Control

The internal MICBIAS circuitry is shown in Figure 18. Note that the maximum source current capability for MICBIAS is 3mA. The external biasing resistors therefore must be large enough to limit the MICBIAS current to 3mA.

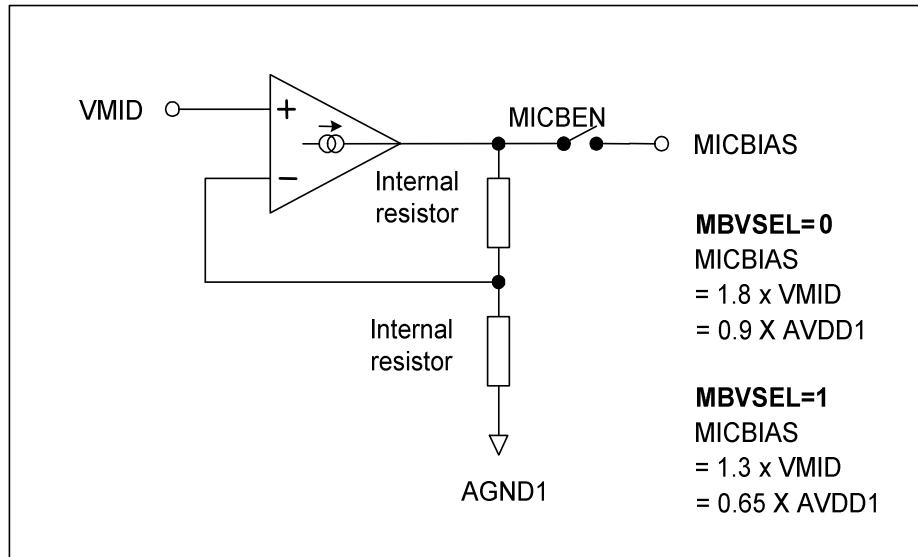


Figure 18 Microphone Bias Schematic

**ANALOGUE TO DIGITAL CONVERTER (ADC)**

The WM8985 uses stereo multi-bit, oversampled sigma-delta ADCs. The use of multi-bit feedback and high oversampling rates reduces the effects of jitter and high frequency noise. The ADC Full Scale input level is proportional to AVDD1. With a 3.3V supply voltage, the full scale level is 1.0V<sub>rms</sub>. Any voltage greater than full scale may overload the ADC and cause distortion.

**ADC DIGITAL FILTERS**

The ADC filters perform true 24 bit signal processing to convert the raw multi-bit oversampled data from the ADC to the correct sampling frequency to be output on the digital audio interface. The digital filter path for each ADC channel is illustrated in Figure 19.

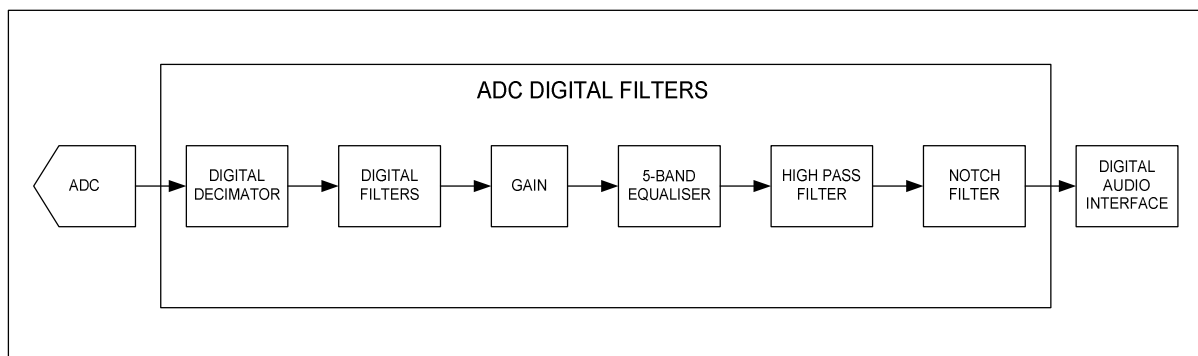


Figure 19 ADC Digital Filter Path

The ADCs are enabled by the ADCENL/R register bit.

REGISTER ADDRESS	BIT	LABEL	DEFAULT	DESCRIPTION
R2 (02h) Power management 2	0	ADCENL	0	Enable ADC left channel: 0 = ADC disabled 1 = ADC enabled
	1	ADCENR	0	Enable ADC right channel: 0 = ADC disabled 1 = ADC enabled

Table 13 ADC Enable Control

The polarity of the output signal can also be changed under software control using the ADCLPOL/ADCRPOL register bit. The oversampling rate of the ADC can be adjusted using the ADCOSR128 register bit. With ADCOSR=0 the oversample rate is 64x which gives lowest power operation and when ADCOSR=1 the oversample rate is 128x which gives best performance.

REGISTER ADDRESS	BIT	LABEL	DEFAULT	DESCRIPTION
R14 (0Eh) ADC Control	0	ADCLPOL	0	ADC left channel polarity adjust: 0 = normal 1 = inverted
	1	ADCRPOL	0	ADC right channel polarity adjust: 0 = normal 1 = inverted
	3	ADCOSR128	0	ADC oversample rate select: 0 = 64x (lower power) 1 = 128x (best performance)

Table 14 ADC Control

### SELECTABLE HIGH PASS FILTER

A selectable high pass filter is provided and enabled as default. To disable this filter set HPFEN=0. The filter has two modes controlled by HPFAPP. In Audio Mode (HPFAPP=0) the filter is first order, with a cut-off frequency of 3.7Hz. In Application Mode (HPFAPP=1) the filter is second order, with a cut-off frequency selectable via the HPFCUT register. The cut-off frequencies when HPFAPP=1 are shown in Table 16.

REGISTER ADDRESS	BIT	LABEL	DEFAULT	DESCRIPTION
R14 (0Eh) ADC Control	6:4	HPFCUT	000	Application mode cut-off frequency See Table 16 for details.
	7	HPFAPP	0	Select audio mode or application mode 0 = Audio mode (1 <sup>st</sup> order, fc = ~3.7Hz) 1 = Application mode (2 <sup>nd</sup> order, fc = HPFCUT)
	8	HPFEN	1	High Pass Filter Enable 0 = disabled 1 = enabled

Table 15 ADC Enable Control

HPFCUT [2:0]	SR=101/100			SR=011/010			SR=001/000		
	fs (kHz)								
	8	11.025	12	16	22.05	24	32	44.1	48
000	82	113	122	82	113	122	82	113	122
001	102	141	153	102	141	153	102	141	153
010	131	180	156	131	180	156	131	180	156
011	163	225	245	163	225	245	163	225	245
100	204	281	306	204	281	306	204	281	306
101	261	360	392	261	360	392	261	360	392
110	327	450	490	327	450	490	327	450	490
111	408	563	612	408	563	612	408	563	612

Table 16 High Pass Filter Cut-off Frequencies (HPFAPP=1)

Note that the High Pass filter values (when HPFAPP=1) are calculated on the assumption that the SR register bits are set correctly for the actual sample rate as shown in Table 16. Sampling rate (SR) is enabled by register bits R7[1:3].

**PROGRAMMABLE NOTCH FILTER**

A programmable notch filter is provided. This filter has a variable centre frequency and bandwidth, programmable via two coefficients, a0 and a1. a0 and a1 are represented by the register bits NFA0[13:0] and NFA1[13:0]. Because these coefficient values require four register writes to setup there is an NFU (Notch Filter Update) flag which should be set only when all four registers are setup.

REGISTER ADDRESS	BIT	LABEL	DEFAULT	DESCRIPTION
R27 (1Bh) Notch Filter 1	6:0	NFA0[13:7]	0	Notch Filter a0 coefficient, bits [13:7]
	7	NFEN	0	Notch filter enable: 0 = Disabled 1 = Enabled
	8	NFU	0	Notch filter update. The notch filter values used internally only update when one of the NFU bits is set high.
R28 (1Ch) Notch Filter 2	6:0	NFA0[6:0]	0	Notch Filter a0 coefficient, bits [6:0]
	8	NFU	0	Notch filter update. The notch filter values used internally only update when one of the NFU bits is set high.
R29 (1Dh) Notch Filter 3	6:0	NFA1[13:7]	0	Notch Filter a1 coefficient, bits [13:7]
	8	NFU	0	Notch filter update. The notch filter values used internally only update when one of the NFU bits is set high.
R30 (1Eh) Notch Filter 4	0-6	NFA1[6:0]	0	Notch Filter a1 coefficient, bits [6:0]
	8	NFU	0	Notch filter update. The notch filter values used internally only update when one of the NFU bits is set high.

**Table 17 Notch Filter Function**

The coefficients are calculated as follows:

$$a_0 = \frac{1 - \tan(w_b / 2)}{1 + \tan(w_b / 2)}$$

$$a_1 = -(1 + a_0)\cos(w_0)$$

Where:

$$w_0 = 2\pi f_c / f_s$$

$$w_b = 2\pi f_b / f_s$$

$f_c$  = centre frequency in Hz,  $f_b$  = -3dB bandwidth in Hz,  $f_s$  = sample frequency in Hz

The actual register values can be determined from the coefficients as follows:

$$NFA0 = -a_0 \times 2^{13}$$

$$NFA1 = -a_1 \times 2^{12}$$

**NOTCH FILTER WORKED EXAMPLE**

The following example illustrates how to calculate the  $a_0$  and  $a_1$  coefficients for a desired centre frequency and -3dB bandwidth.

$$f_c = 1000 \text{ Hz}$$

$$f_b = 100 \text{ Hz}$$

$$f_s = 48000 \text{ Hz}$$

$$w_0 = 2\pi f_c / f_s = 2\pi \times (1000 / 48000) = 0.1308996939 \text{ rads}$$

$$w_b = 2\pi f_b / f_s = 2\pi \times (100 / 48000) = 0.01308996939 \text{ rads}$$

$$a_0 = \frac{1 - \tan(w_b / 2)}{1 + \tan(w_b / 2)} = \frac{1 - \tan(0.01308996939 / 2)}{1 + \tan(0.01308996939 / 2)} = 0.9869949627$$

$$a_1 = -(1 + a_0) \cos(w_0) = -(1 + 0.9869949627) \cos(0.1308996939) = -1.969995945$$

$$\text{NFA0} = -a_0 \times 2^{13} = -8085 \text{ (rounded to nearest whole number)}$$

$$\text{NFA1} = -a_1 \times 2^{12} = 8069 \text{ (rounded to nearest whole number)}$$

These values are then converted to a 14-bit sign / magnitude notation:

$$\text{NFA0}[13] = 1; \text{NFA0}[12:0] = 13'h1F95; \text{NFA0} = 14'h3F95 = 14'b11111110010101$$

$$\text{NFA1}[13] = 0; \text{NFA1}[12:0] = 13'h1F85; \text{NFA1} = 14'h1F85 = 14'b01111110000101$$

**DIGITAL ADC VOLUME CONTROL**

The output of the ADCs can be digitally attenuated over a range from -127dB to 0dB in 0.5dB steps. The gain for a given eight-bit code X is given by:

$$0.5 \times (G-255) \text{ dB for } 1 \leq G \leq 255; \quad \text{MUTE for } G = 0$$

REGISTER ADDRESS	BIT	LABEL	DEFAULT	DESCRIPTION
R15 (0Fh) Left channel ADC Digital Volume	7:0	ADCLVOL [7:0]	11111111 ( 0dB )	Left ADC Digital Volume Control 0000 0000 = Digital Mute 0000 0001 = -127dB 0000 0010 = -126.5dB ... 0.5dB steps up to 1111 1111 = 0dB
	8	ADCVU	Not latched	ADC left and ADC right volume do not update until a 1 is written to ADCVU (in reg 15 or 16)
R16 (10h) Right channel ADC Digital Volume	7:0	ADCRVOL [7:0]	11111111 ( 0dB )	Right ADC Digital Volume Control 0000 0000 = Digital Mute 0000 0001 = -127dB 0000 0010 = -126.5dB ... 0.5dB steps up to 1111 1111 = 0dB
	8	ADCVU	Not latched	ADC left and ADC right volume do not update until a 1 is written to ADCVU (in reg 15 or 16)

**Table 18 ADC Digital Volume Control**

**INPUT LIMITER / AUTOMATIC LEVEL CONTROL (ALC)**

The WM8985 has an automatic PGA gain control circuit, which can function as an input peak limiter or as an automatic level control (ALC).

The Automatic Level Control (ALC) provides continuous adjustment of the input PGA in response to the amplitude of the input signal. A digital peak detector monitors the input signal amplitude and compares it to a register defined threshold level (ALCLVL).

If the signal is below the threshold, the ALC will increase the gain of the PGA at a rate set by ALCDCY. If the signal is above the threshold, the ALC will reduce the gain of the PGA at a rate set by ALCATK.

The ALC has two modes selected by the ALCMODE register: normal mode and peak limiter mode. The ALC/limiter function is enabled by settings the register bits R32[8:7] ALCSEL.

REGISTER ADDRESS	BIT	LABEL	DEFAULT	DESCRIPTION
R32 (20h) ALC Control 1	2:0	ALCMIN [2:0]	000 (-12dB)	Set minimum gain of PGA 000 = -12dB 001 = -6dB 010 = 0dB 011 = +6dB 100 = +12dB 101 = +18dB 110 = +24dB 111 = +30dB
	5:3	ALCMAX [2:0]	111 (+35.25dB)	Set Maximum Gain of PGA 111 = +35.25dB 110 = +29.25dB 101 = +23.25dB 100 = +17.25dB 011 = +11.25dB 010 = +5.25dB 001 = -0.75dB 000 = -6.75dB
	8:7	ALCSEL	00	ALC function select 00 = ALC disabled 01 = Right channel ALC enabled 10 = Left channel ALC enabled 11 = Both channels ALC enabled
R33 (21h) ALC Control 2	3:0	ALCLVL [3:0]	1011 (-6dB)	ALC target – sets signal level at ADC input 1111 = -1.5dBFS 1110 = -1.5dBFS 1101 = -3dBFS 1100 = -4.5dBFS 1011 = -6dBFS 1010 = -7.5dBFS 1001 = -9dBFS 1000 = -10.5dBFS 0111 = -12dBFS 0110 = -13.5dBFS 0101 = -15dBFS 0100 = -16.5dBFS 0011 = -18dBFS 0010 = -19.5dBFS 0001 = -21dBFS

REGISTER ADDRESS	BIT	LABEL	DEFAULT	DESCRIPTION			
				0000 = -22.5dBFS			
	7:4	ALCHLD [3:0]	0000 (0ms)	ALC hold time before gain is increased. 0000 = 0ms 0001 = 2.67ms 0010 = 5.33ms 0011 = 10.66ms 0100 = 21.32ms 0101 = 42.64ms 0110 = 85.28ms 0111 = 0.17s 1000 = 0.34s 1001 = 0.68s 1010 or higher = 1.36s			
R34 (22h) ALC Control 3	8	ALCMODE	0	Determines the ALC mode of operation: 0 = ALC mode (Normal Operation) 1 = Limiter mode.			
	7:4	ALCDCY [3:0]	0011 (13ms/6dB)	Decay (gain ramp-up) time (ALCMODE ==0)			
					Per step	Per 6dB	90% of range
				0000	410us	3.3ms	24ms
				0001	820us	6.6ms	48ms
				0010	1.64ms	13.1ms	192ms
				... (time doubles with every step)			
				1010 or higher	420ms	3.36s	24.576s
				0011 (2.9ms/6dB)	Decay (gain ramp-up) time (ALCMODE ==1)		
						Per step	Per 6dB
0000					90.8us	726.4us	5.26ms
0001	181.6us	1.453ms	10.53 ms				
0010	363.2us	2.905ms	21.06 ms				
... (time doubles with every step)							
1010	93ms	744ms	5.39s				
3:0	ALCATK [3:0]	0010 (832us/6dB)	ALC attack (gain ramp-down) time (ALCMODE == 0)				
				Per step	Per 6dB	90% of range	
			0000	104us	832us	6ms	
			0001	208us	1.66ms	12ms	
			0010	416us	3.32ms	24.1ms	
			... (time doubles with every step)				
			1010 or higher	106ms	852ms	6.18s	
			0010 (182us/6dB)	ALC attack (gain ramp-down) time (ALCMODE == 1)			
					Per step	Per 6dB	90% of range
				0000	22.7us	182.4us	1.31ms

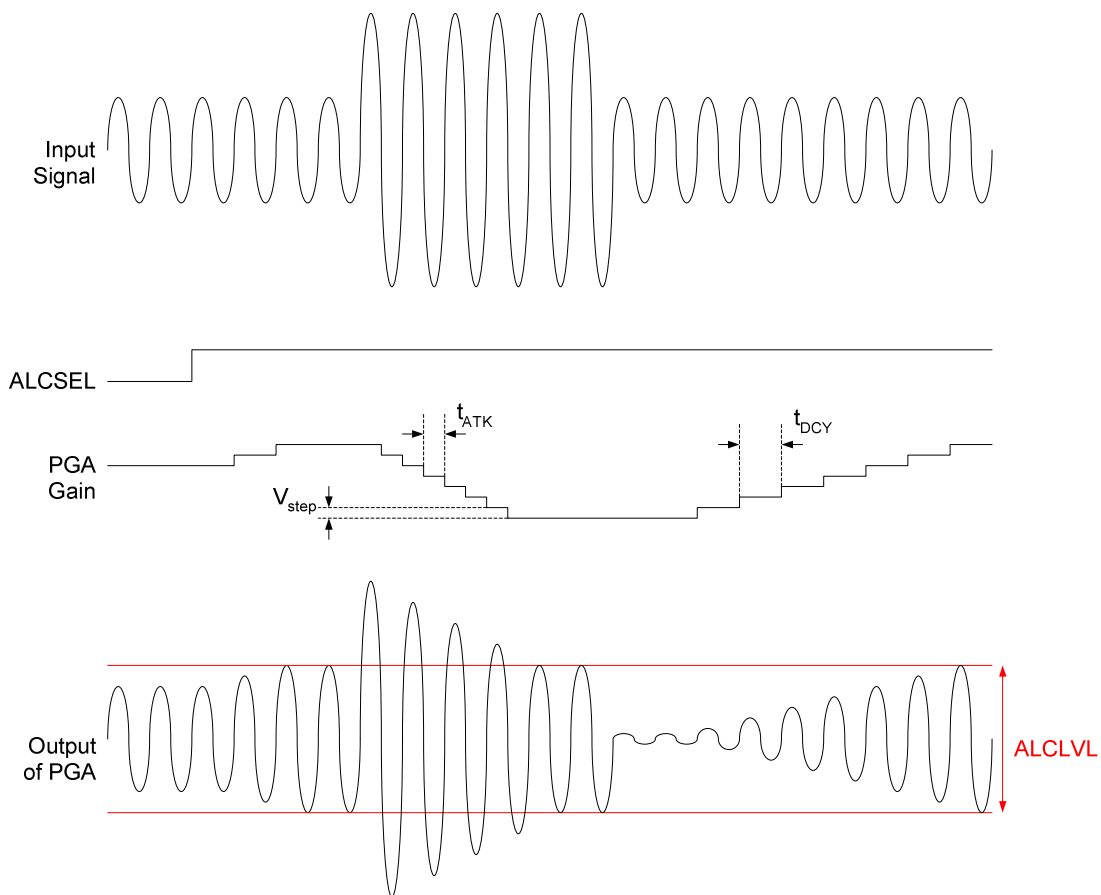
REGISTER ADDRESS	BIT	LABEL	DEFAULT	DESCRIPTION			
				0001	45.4us	363.2us	2.62ms
				0010	90.8us	726.4us	5.26ms
				... (time doubles with every step)			
				1010	23.2ms	186ms	1.348s

**Table 20 ALC Control Registers**

When the ALC is disabled, the input PGA remains at the last controlled value of the ALC. An input gain update must be made by writing to the INPPGAVOLL/R register bits.

**NORMAL MODE**

In normal mode, the ALC will attempt to maintain a constant signal level by increasing or decreasing the gain of the PGA. The following diagram shows an example of this.



**Figure 21 ALC Normal Mode Operation**

## LIMITER MODE

In limiter mode, the ALC will reduce peaks that go above the threshold level, but will not increase the PGA gain beyond the starting level. The starting level is the PGA gain setting when the ALC is enabled in limiter mode. If the ALC is started in limiter mode, this is the gain setting of the PGA at startup. If the ALC is switched into limiter mode after running in ALC mode, the starting gain will be the gain at switchover. The diagram below shows an example of limiter mode.

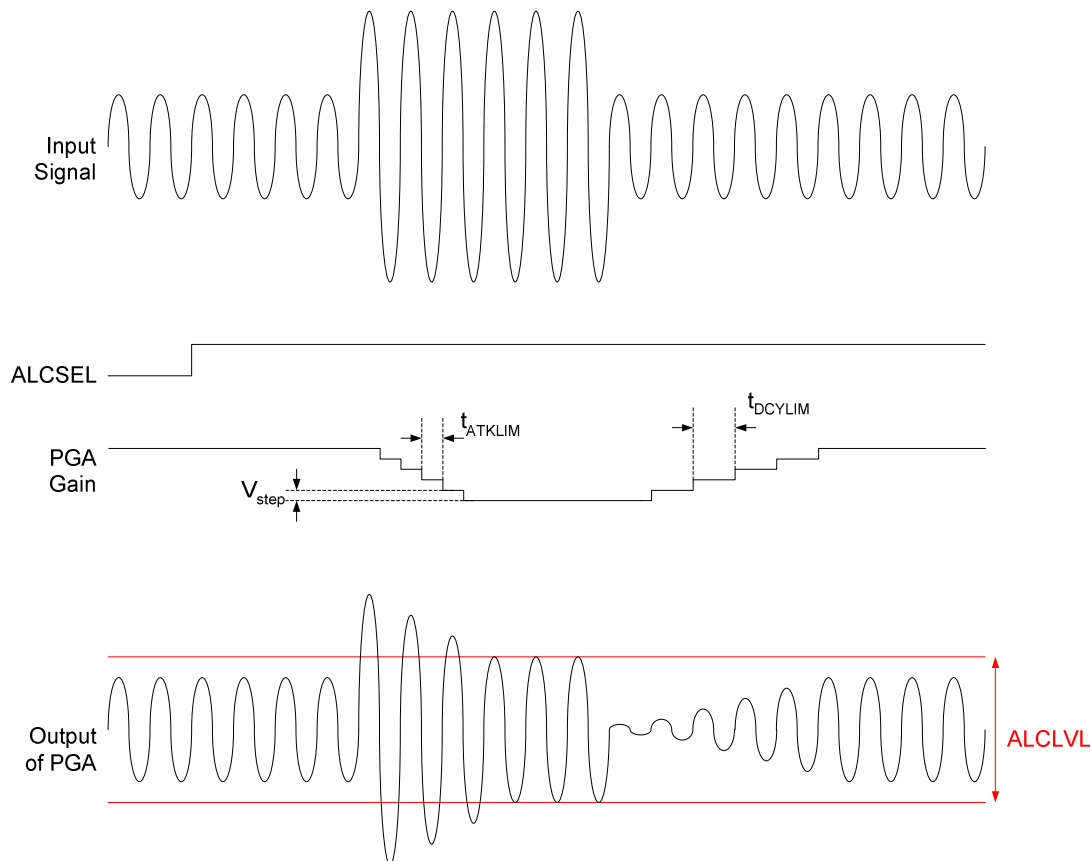


Figure 20 ALC Limiter Mode Operation

### ATTACK AND DECAY TIMES

The attack and decay times set the update times for the PGA gain. The attack time is the time constant used when the gain is reducing. The decay time is the time constant used when the gain is increasing. In limiter mode, the time constants are faster than in ALC mode. The time constants are shown below in terms of a single gain step, a change of 6dB and a change of 90% of the PGAs gain range.

Note that, these times will vary slightly depending on the sample rate used (specified by the SR register).

**NORMAL MODE**

ALCMODE = 0 (Normal Mode)			
Attack Time (s)			
ALCATK	t <sub>ATK</sub>	t <sub>ATK6dB</sub>	t <sub>ATK90%</sub>
0000	104μs	832μs	6ms
0001	208μs	1.66ms	12ms
0010	416μs	3.33ms	24ms
0011	832μs	6.66ms	48ms
0100	1.66ms	13.3ms	96ms
0101	3.33ms	26.6ms	192ms
0110	6.66ms	53.2ms	384ms
0111	13.3ms	106ms	767ms
1000	26.6ms	213.2ms	1.53s
1001	53.2ms	426ms	3.07s
1010	106ms	852ms	6.13s

ALCMODE = 0 (Normal Mode)			
Decay Time (s)			
ALCDCY	t <sub>DCY</sub>	t <sub>DCY6dB</sub>	t <sub>DCY90%</sub>
0000	410μs	3.28ms	23.6ms
0001	820μs	6.56ms	47.2ms
0010	1.64ms	13.1ms	94.5ms
0011	3.28ms	26.2ms	189ms
0100	6.56ms	52.5ms	378ms
0101	13.1ms	105ms	756ms
0110	26.2ms	210ms	1.51s
0111	52.5ms	420ms	3.02s
1000	105ms	840ms	6.05s
1001	210ms	1.68s	12.1s
1010	420ms	3.36s	24.2s

Table 19 ALC Normal Mode (Attack and Decay times)

**LIMITER MODE**

ALCMODE = 1 (Limiter Mode)			
	Attack Time (s)		
ALCATK	$t_{\text{ATKLIM}}$	$t_{\text{ATKLIM6dB}}$	$t_{\text{ATKLIM90\%}}$
0000	22.7 $\mu$ s	182 $\mu$ s	1.31ms
0001	45.4 $\mu$ S	363 $\mu$ s	2.62ms
0010	90.8 $\mu$ S	726 $\mu$ s	5.23ms
0011	182 $\mu$ S	1.45ms	10.5ms
0100	363 $\mu$ S	2.91ms	20.9ms
0101	726 $\mu$ S	5.81ms	41.8ms
0110	1.45ms	11.6ms	83.7ms
0111	2.9ms	23.2ms	167ms
1000	5.81ms	46.5ms	335ms
1001	11.6ms	93ms	669ms
1010	23.2ms	186ms	1.34s

ALCMODE = 1 (Limiter Mode)			
	Attack Time (s)		
ALCDCY	$t_{\text{DCYLIM}}$	$t_{\text{DCYLIM6dB}}$	$t_{\text{DCYLIM90\%}}$
0000	90.8 $\mu$ s	726 $\mu$ s	5.23ms
0001	182 $\mu$ S	1.45ms	10.5ms
0010	363 $\mu$ S	2.91ms	20.9ms
0011	726 $\mu$ S	5.81ms	41.8ms
0100	1.45ms	11.6ms	83.7ms
0101	2.91ms	23.2ms	167ms
0110	5.81ms	46.5ms	335ms
0111	11.6ms	93ms	669ms
1000	23.2ms	186ms	1.34s
1001	46.5ms	372ms	2.68s
1010	93ms	744ms	5.36s

Table 20 ALC Limiter Mode (Attack and Decay times)

### MINIMUM AND MAXIMUM GAIN

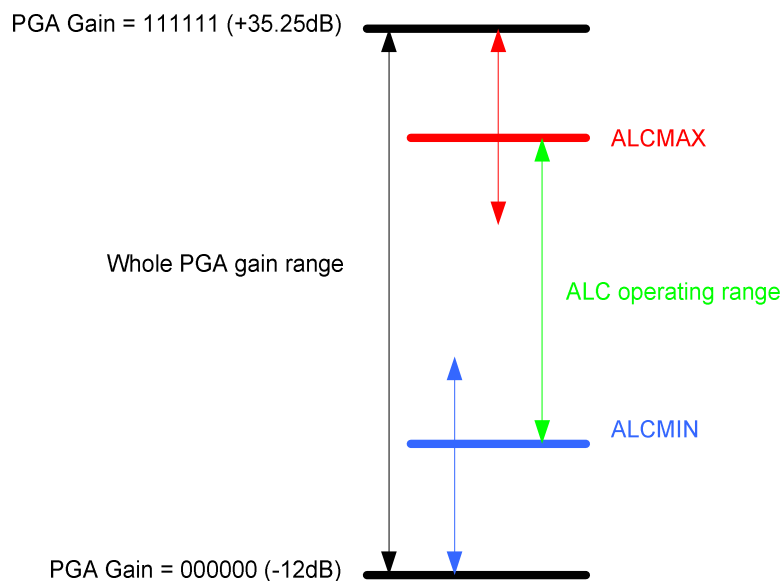
The ALCMIN and ALCMAX register bits set the minimum/maximum gain value that the PGA can be set to whilst under the control of the ALC. This has no effect on the PGA when ALC is not enabled.

REGISTER ADDRESS	BIT	LABEL	DEFAULT	DESCRIPTION
R32	5:3	ALCMAX	111	Set Maximum Gain of PGA
ALC Control 1	2:0	ALCMIN	000	Set minimum gain of PGA

**Table 23 ALC Max/Min Gain**

In normal mode, ALCMAX sets the maximum boost which can be applied to the signal. In limiter mode, ALCMAX will normally have no effect (assuming the starting gain value is less than the maximum gain specified by ALCMAX) because the maximum gain is set at the starting gain level.

ALCMIN sets the minimum gain value which can be applied to the signal.



**Figure 23 ALC Min/Max Gain**

ALCMAX	Maximum Gain (dB)
111	35.25
110	29.25
101	23.25
100	17.25
011	11.25
010	5.25
001	-0.75
000	-6.75

**Table 24 ALC Max Gain Values**

ALCMIN	Minimum Gain (dB)
000	-12
001	-6
010	0
011	6
100	12
101	18
110	24
111	30

**Table 25 ALC Min Gain Values**

Note that if the ALC gain setting strays outside the ALC operating range, either by starting the ALC outside of the range or changing the ALCMAX or ALCMIN settings during operation, the ALC will immediately adjust the gain to return to the ALC operating range. It is recommended that the ALC starting gain is set between the ALCMAX and ALCMIN limits.

**ALC HOLD TIME (NORMAL MODE ONLY)**

In Normal mode, the ALC has an adjustable hold time which sets a time delay before the ALC begins its decay phase (gain increasing). The hold time is set by the ALCHLD register.

REGISTER ADDRESS	BIT	LABEL	DEFAULT	DESCRIPTION
R33 ALC Control 2	7:4	ALCHLD	0000	ALC hold time before gain is increased.

**Table 26 ALC Hold Time**

If the hold time is exceeded this indicates that the signal has reached a new average level and the ALC will increase the gain to adjust for that new average level. If the signal goes above the threshold during the hold period, the hold phase is abandoned and the ALC returns to normal operation.

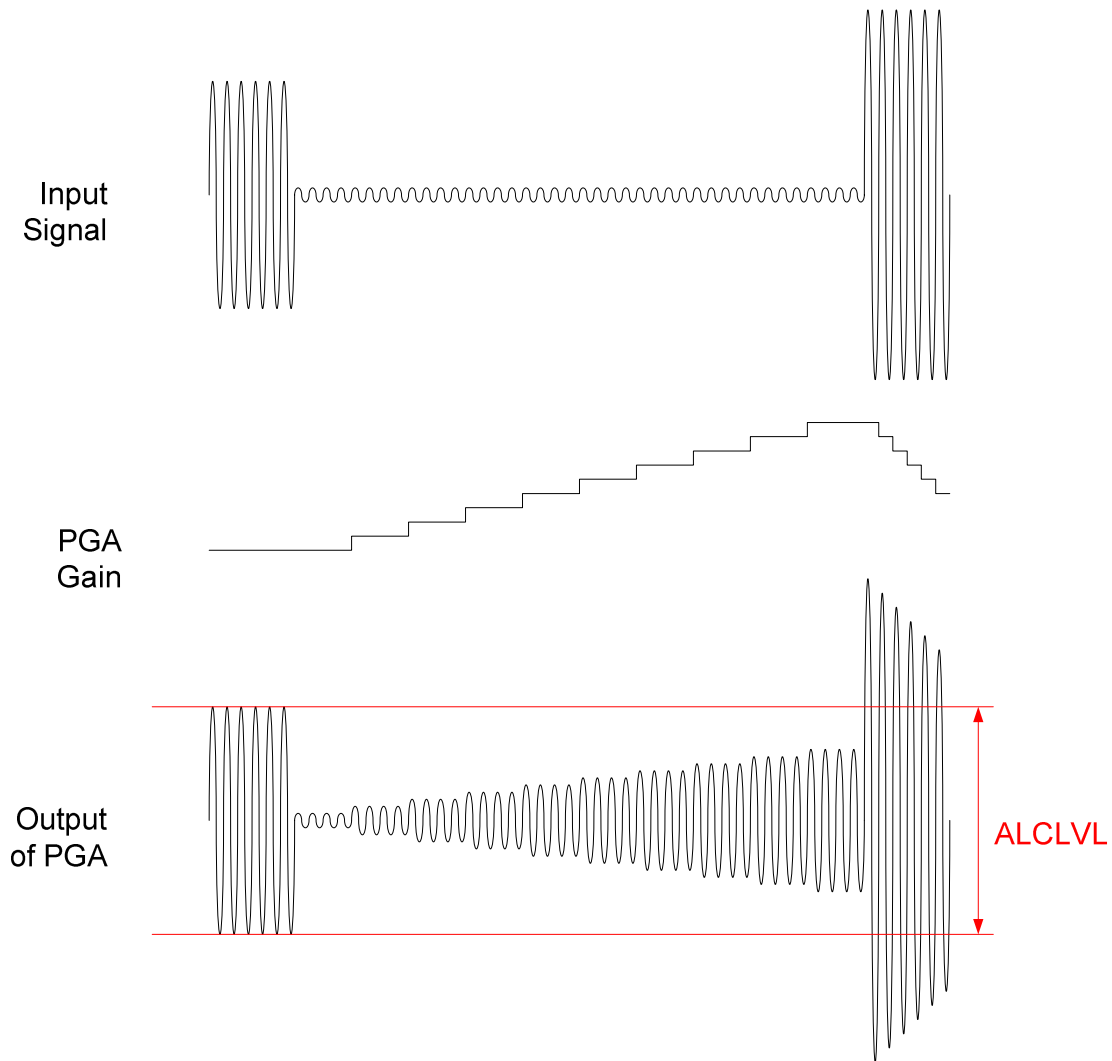


Figure 24 ALCLVL

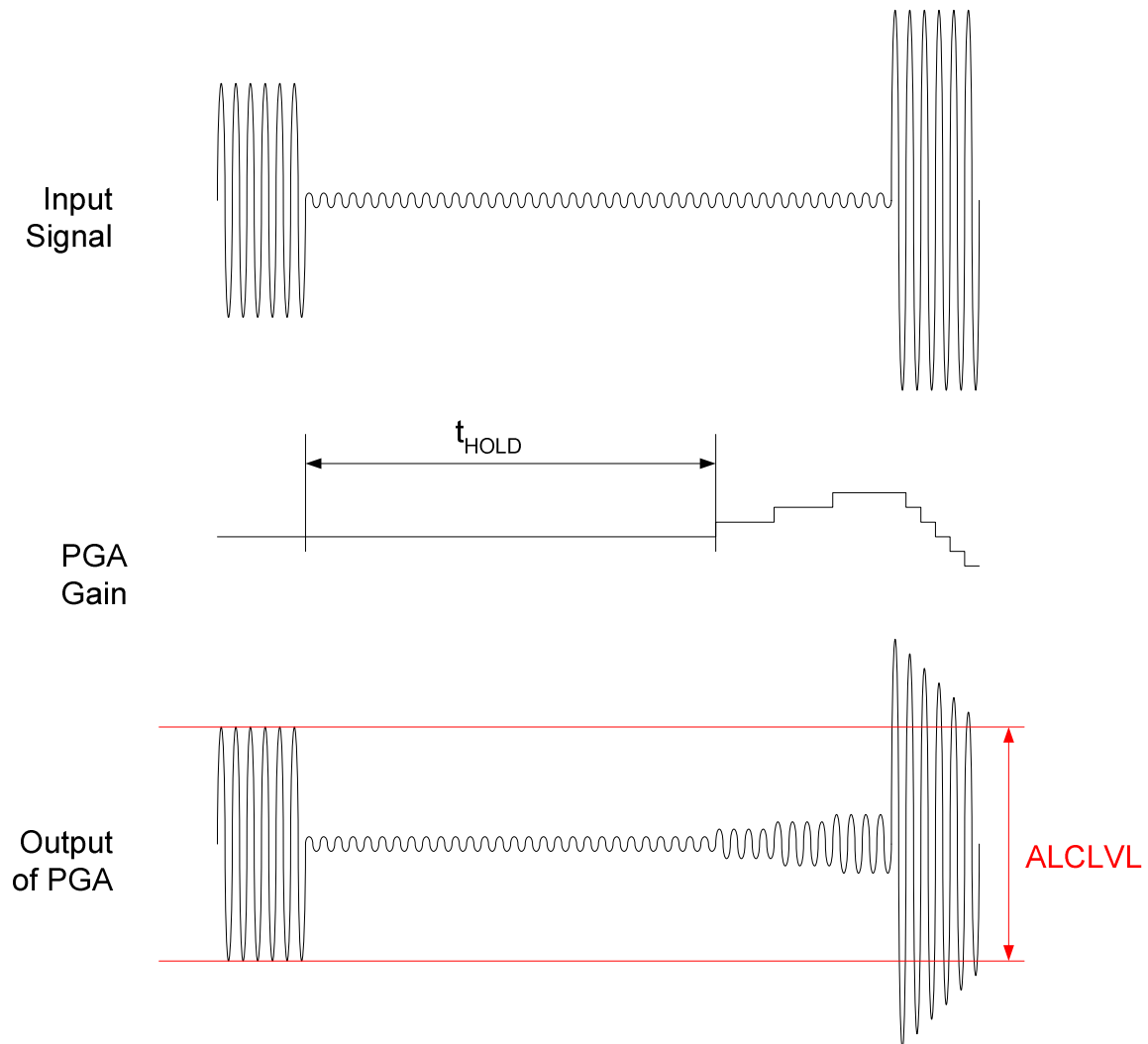


Figure 25 ALC Hold Time

ALCHLD	$t_{\text{HOLD}}$ (s)
0000	0
0001	2.67ms
0010	5.34ms
0011	10.7ms
0100	21.4ms
0101	42.7ms
0110	85.4ms
0111	171ms
1000	342ms
1001	684ms
1010	1.37s

Table 27 ALC Hold Time Values

### PEAK LIMITER

To prevent clipping when a large signal occurs just after a period of quiet, the ALC circuit includes a limiter function. If the ADC input signal exceeds 87.5% of full scale (-1.16dB), the PGA gain is ramped down at the maximum attack rate (as when ALCATK = 0000), until the signal level falls below 87.5% of full scale. This function is automatically enabled whenever the ALC is enabled.

**Note:** If ALCATK = 0000, then the limiter makes no difference to the operation of the ALC. It is designed to prevent clipping when long attack times are used.

### NOISE GATE (NORMAL MODE ONLY)

When the signal is very quiet and consists mainly of noise, the ALC function may cause “noise pumping”, i.e. loud hissing noise during silence periods. The WM8985 has a noise gate function that prevents noise pumping by comparing the signal level at the input pins against a noise gate threshold, NGTH. The noise gate cuts in when:

$$\text{Signal level at ADC [dBFS]} < \text{NGTH [dBFS]} + \text{PGA gain [dB]} + \text{Mic Boost gain [dB]}$$

This is equivalent to:

$$\text{Signal level at input pin [dBFS]} < \text{NGTH [dBFS]}$$

The PGA gain is then held constant (preventing it from ramping up as it normally would when the signal is quiet).

The table below summarises the noise gate control register. The NGTH control bits set the noise gate threshold with respect to the ADC full-scale range. The threshold is adjusted in 6dB steps. Levels at the extremes of the range may cause inappropriate operation, so care should be taken with set-up of the function. The noise gate only operates in conjunction with the ALC and cannot be used in limiter mode.

REGISTER ADDRESS	BIT	LABEL	DEFAULT	DESCRIPTION
R35 (23h) ALC Noise Gate Control	2:0	NGTH	000	Noise gate threshold: 000 = -39dB 001 = -45dB 010 = -51db 011 = -57dB 100 = -63dB 101 = -70dB 110 = -76dB 111 = -81dB
	3	NGATEN	0	Noise gate function enable 1 = enable 0 = disable

**Table 28 ALC Noise Gate Control**

The diagrams below show the response of the system to the same signal with and without noise gate.

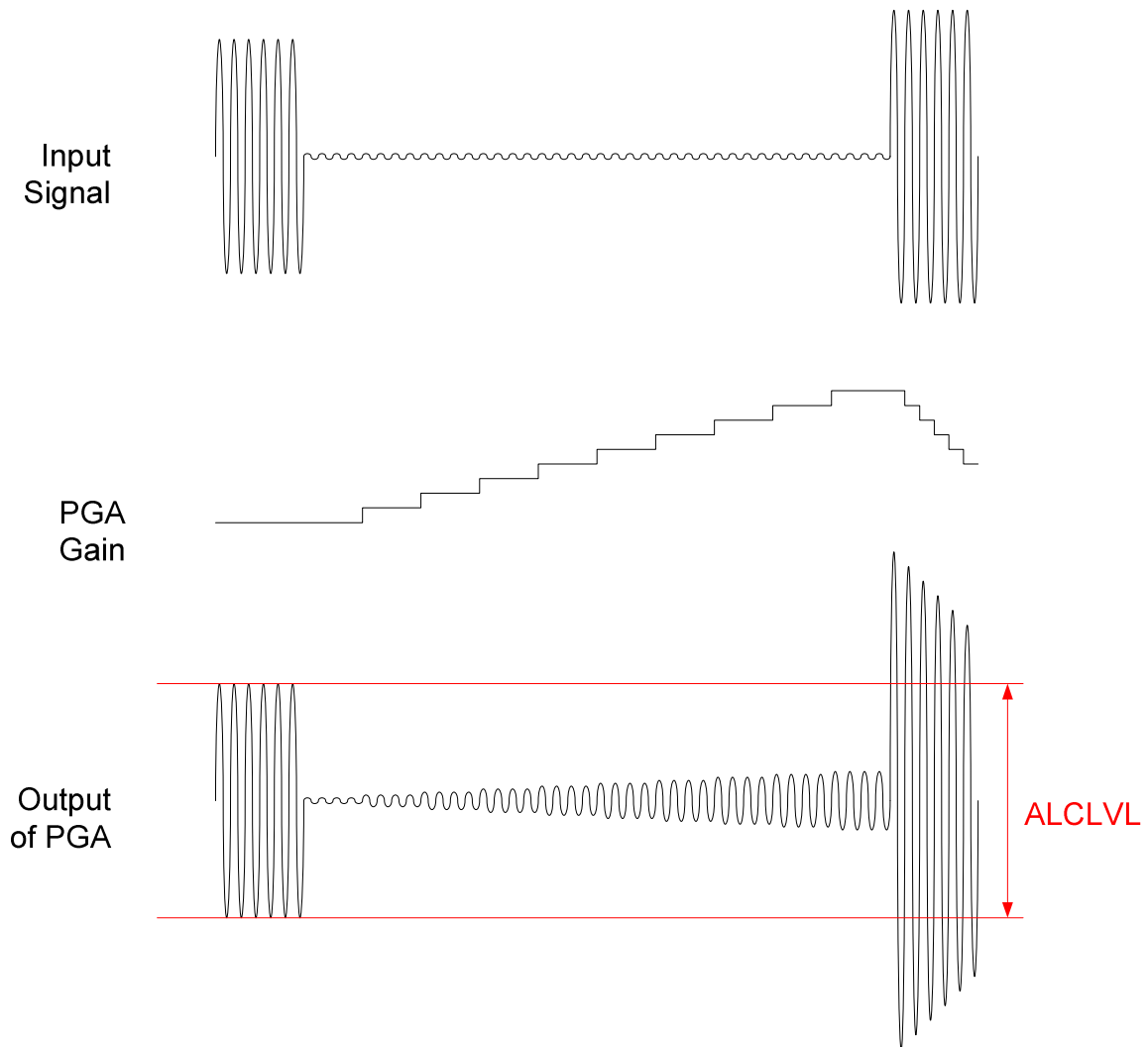


Figure 21 ALC Operation Above Noise Gate Threshold

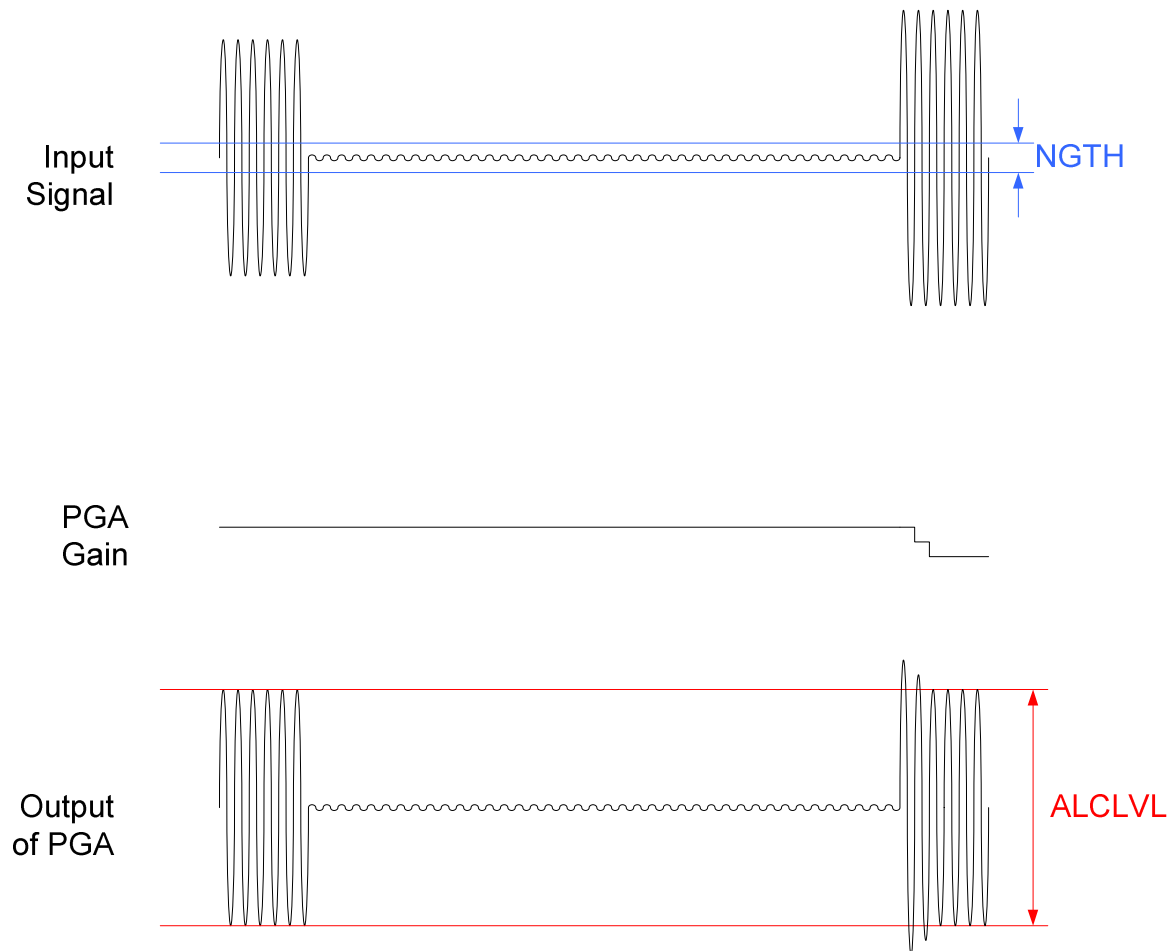


Figure 22 Noise Gate Operation

## OUTPUT SIGNAL PATH

The WM8985 output signal paths consist of digital application filters, up-sampling filters, stereo Hi-Fi DACs, analogue mixers, stereo headphone and stereo line/mono/midrail output drivers. The digital filters and DAC are enabled by register bits DACENL and DACENR. The mixers and output drivers can be separately enabled by individual control bits (see Analogue Outputs). Thus it is possible to utilise the analogue mixing and amplification provided by the WM8985, irrespective of whether the DACs are running or not.

The WM8985 DACs receive digital input data on the DACDAT pin. The digital filter block processes the data to provide the following functions:

- Digital volume control
- Graphic equaliser
- A digital peak limiter
- Sigma-Delta Modulation

High performance sigma-delta audio DAC converts the digital data into an analogue signal.

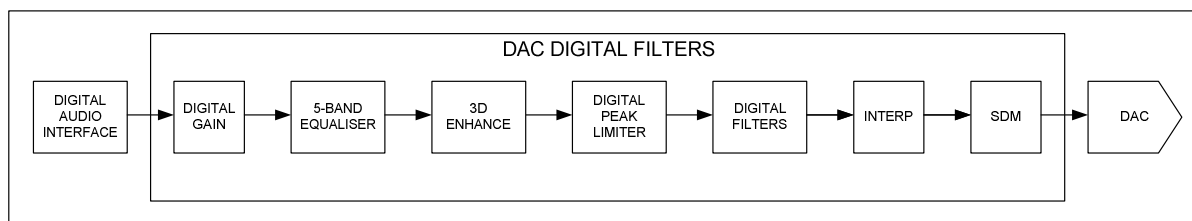


Figure 23 DAC Digital Filter Path

The analogue outputs from the DACs can then be mixed with the aux analogue inputs and the ADC analogue inputs. The mix is fed to the output drivers for headphone (LOUT1/ROUT1, LOUT2/ROUT2) or line (OUT3/OUT4). OUT3 and OUT4 have additional mixers which allow them to output different signals to the line outputs or back into the record path.

### DIGITAL PLAYBACK (DAC) PATH

Digital data is passed to the WM8985 via the flexible audio interface and is then passed through a variety of advanced digital filters as shown in Figure 23 to the hi-fi DACs. The DACs are enabled by the DACENL/R register bits.

REGISTER ADDRESS	BIT	LABEL	DEFAULT	DESCRIPTION
R3 (03h) Power Management 3	0	DACENL	0	Left channel DAC enable 0 = DAC disabled 1 = DAC enabled
	1	DACENR	0	Right channel DAC enable 0 = DAC disabled 1 = DAC enabled

Table 21 DAC Enable Control

The WM8985 also has a Soft Mute function, which when enabled, gradually attenuates the volume of the digital signal to zero. When disabled, the gain will ramp back up to the digital gain setting. This function is enabled by default. To play back an audio signal, it must first be disabled by setting the SOFTMUTE bit to zero.

REGISTER ADDRESS	BIT	LABEL	DEFAULT	DESCRIPTION
R10 (0Ah) DAC Control	0	DACPOL	0	Left DAC output polarity: 0 = non-inverted 1 = inverted (180 degrees phase shift)
	1	DACRPOL	0	Right DAC output polarity: 0 = non-inverted 1 = inverted (180 degrees phase shift)
	2	AMUTE	0	Automute enable 0 = Amute disabled 1 = Amute enabled
	3	DACOSR128	0	DAC oversampling rate: 0 = 64x (lowest power) 1 = 128x (best performance)
	6	SOFTMUTE	0	Softmute enable: 0 = Enabled 1 = Disabled

Table 22 DAC Control Register

The digital audio data is converted to oversampled bit streams in the on-chip, true 24-bit digital interpolation filters. The bitstream data enters the multi-bit, sigma-delta DACs, which convert it to a high quality analogue audio signal. The multi-bit DAC architecture reduces high frequency noise and sensitivity to clock jitter. It also uses a Dynamic Element Matching technique for high linearity and low distortion.

The DAC output phase defaults to non-inverted. Setting DACLPOL will invert the DAC output phase on the left channel and DACRPOL inverts the phase on the right channel.

### AUTO-MUTE

The DAC has an auto-mute function which applies an analogue mute when 1024 consecutive zeros are detected. The mute is released as soon as a non-zero sample is detected. Auto-mute can be disabled using the AMUTE control bit.

### DIGITAL HI-FI DAC VOLUME (GAIN) CONTROL

The signal volume from each Hi-Fi DAC can be controlled digitally. The gain range is  $-127\text{dB}$  to  $0\text{dB}$  in  $0.5\text{dB}$  steps. The level of attenuation for an eight-bit code X is given by:

$$0.5 \times (X-255) \text{ dB for } 1 \leq X \leq 255; \quad \text{MUTE for } X = 0$$

REGISTER ADDRESS	BIT	LABEL	DEFAULT	DESCRIPTION
R11 (0Bh) Left DAC Digital Volume	7:0	DACLVOL [7:0]	11111111 ( 0dB )	Left DAC Digital Volume Control 0000 0000 = Digital Mute 0000 0001 = -127dB 0000 0010 = -126.5dB ... 0.5dB steps up to 1111 1111 = 0dB
	8	DACVU	Not latched	DAC left and DAC right volume do not update until a 1 is written to DACVU (in reg 11 or 12)
R12 (0Ch) Right DAC Digital Volume	7:0	DACRVOL [7:0]	11111111 ( 0dB )	Right DAC Digital Volume Control 0000 0000 = Digital Mute 0000 0001 = -127dB 0000 0010 = -126.5dB ... 0.5dB steps up to 1111 1111 = 0dB
	8	DACVU	Not latched	DAC left and DAC right volume do not update until a 1 is written to DACVU (in reg 11 or 12)

**Table 23 DAC Digital Volume Control**

**Note:** An additional gain of up to 12dB can be added using the gain block embedded in the digital peak limiter circuit (see DAC OUTPUT LIMITER section).

### 5-BAND EQUALISER

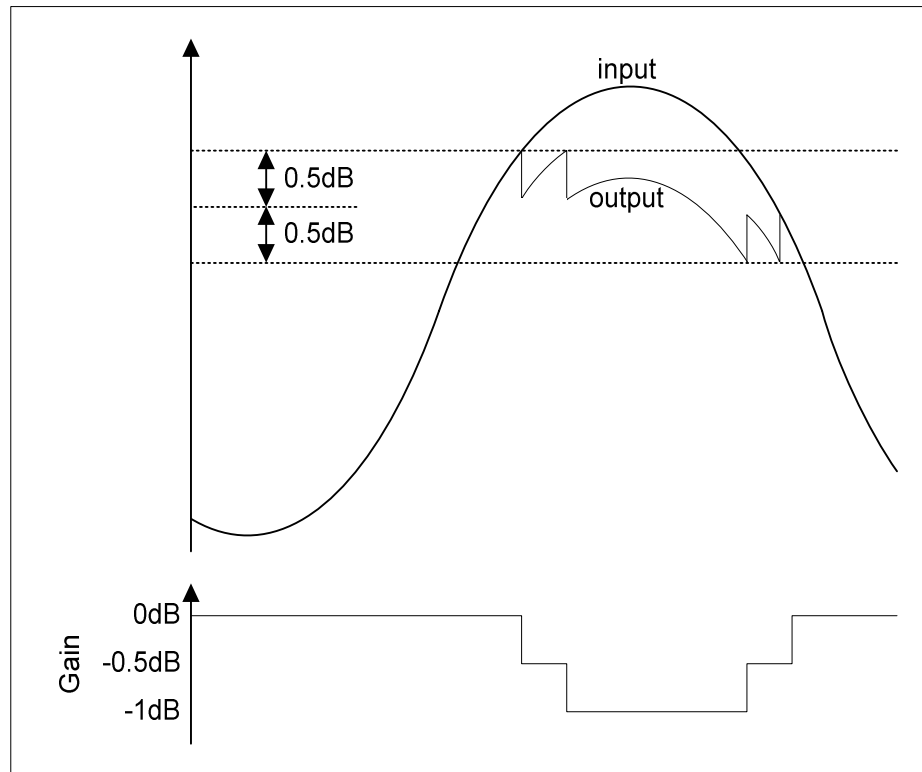
A 5-band graphic equaliser function which can be used to change the output frequency levels to suit the environment. This can be applied to the ADC or DAC path and is described in the 5-BAND EQUALISER section for further details on this feature.

### 3-D ENHANCEMENT

The WM8985 has an advanced digital 3-D enhancement feature which can be used to vary the perceived stereo separation of the left and right channels. Like the 5-band equaliser this feature can be applied to either the ADC record path or the DAC playback path but not both simultaneously. Refer to the 3-D STEREO ENHANCEMENT section for further details on this feature.

### DAC DIGITAL OUTPUT LIMITER

The WM8985 has a digital output limiter function. The operation of this is shown in Figure 24. In this diagram the upper graph shows the envelope of the input/output signals and the lower graph shows the gain characteristic.



**Figure 24 DAC Digital Limiter Operation**

The limiter has a programmable upper threshold which is close to 0dB. Referring to Figure 24, in normal operation (LIMBOOST=000 => limit only) signals below this threshold are unaffected by the limiter. Signals above the upper threshold are attenuated at a specific attack rate (set by the LIMATK register bits) until the signal falls below the threshold. The limiter also has a lower threshold 1dB below the upper threshold. When the signal falls below the lower threshold the signal is amplified at a specific decay rate (controlled by LIMDCY register bits) until a gain of 0dB is reached. Both threshold levels are controlled by the LIMLVL register bits. The upper threshold is 0.5dB above the value programmed by LIMLVL and the lower threshold is 0.5dB below the LIMLVL value.

### VOLUME BOOST

The limiter has programmable upper gain which boosts signals below the threshold to compress the dynamic range of the signal and increase its perceived loudness. This operates as an ALC function with limited boost capability. The volume boost is from 0dB to +12dB in 1dB steps, controlled by the LIMBOOST register bits.

The output limiter volume boost can also be used as a stand alone digital gain boost when the limiter is disabled.

REGISTER ADDRESS	BIT	LABEL	DEFAULT	DESCRIPTION
R24 (18h) DAC digital limiter control 1	3:0	LIMATK	0010	Limiter Attack time (per 6dB gain change) for 44.1kHz sampling. Note that these are proportionally related to sample rate. 0000 = 94us 0001 = 188s 0010 = 375us 0011 = 750us 0100 = 1.5ms 0101 = 3ms 0110 = 6ms 0111 = 12ms 1000 = 24ms 1001 = 48ms 1010 = 96ms 1011 to 1111 = 192ms
	7:4	LIMDCY	0011	Limiter Decay time (per 6dB gain change) for 44.1kHz sampling. Note that these are proportionally related to sample rate: 0000 = 750us 0001 = 1.5ms 0010 = 3ms 0011 = 6ms 0100 = 12ms 0101 = 24ms 0110 = 48ms 0111 = 96ms 1000 = 192ms 1001 = 384ms 1010 = 768ms 1011 to 1111 = 1.536s
	8	LIMEN	0	Enable the DAC digital limiter: 0=disabled 1=enabled
R25 (19h) DAC digital limiter control 2	3:0	LIMBOOST	0000	Limiter volume boost (can be used as a stand alone volume boost when LIMEN=0): 0000 = 0dB 0001 = +1dB 0010 = +2dB 0011 = +3dB 0100 = +4dB 0101 = +5dB 0110 = +6dB 0111 = +7dB 1000 = +8dB 1001 = +9dB 1010 = +10dB 1011 = +11dB 1100 = +12dB 1101 to 1111 = reserved

REGISTER ADDRESS	BIT	LABEL	DEFAULT	DESCRIPTION
	6:4	LIMLVL	000	Programmable signal threshold level (determines level at which the limiter starts to operate) 000 = -1dB 001 = -2dB 010 = -3dB 011 = -4dB 100 = -5dB 101 to 111 = -6dB

Table 24 DAC Digital Limiter Control

**5-BAND GRAPHIC EQUALISER**

A 5-band graphic equaliser is provided, which can be applied to the ADC or DAC path, together with 3D enhancement, under control of the EQ3DMODE register bit.

REGISTER ADDRESS	BIT	LABEL	DEFAULT	DESCRIPTION
R18 (12h) EQ Control 1	8	EQ3DMODE	1	0 = Equaliser and 3D Enhancement applied to ADC path 1 = Equaliser and 3D Enhancement applied to DAC path

Table 25 EQ and 3D Enhancement DAC or ADC Path Select

**Note:** The ADCs and DACs must be disabled before changing the EQ3DMODE bit.

The equaliser consists of low and high frequency shelving filters (Band 1 and 5) and three peak filters for the centre bands. Each has adjustable cut-off or centre frequency, and selectable boost (+/- 12dB in 1dB steps). The peak filters have selectable bandwidth.

REGISTER ADDRESS	BIT	LABEL	DEFAULT	DESCRIPTION
R18 (12h) EQ Band 1 Control	4:0	EQ1G	01100 (0dB)	Band 1 Gain Control. See Table 31 for details.
	6:5	EQ1C	01	Band 1 Cut-off Frequency: 00 = 80Hz 01 = 105Hz 10 = 135Hz 11 = 175Hz

Table 26 EQ Band 1 Control

REGISTER ADDRESS	BIT	LABEL	DEFAULT	DESCRIPTION
R19 (13h) EQ Band 2 Control	4:0	EQ2G	01100 (0dB)	Band 2 Gain Control. See Table 31 for details.
	6:5	EQ2C	01	Band 2 Centre Frequency: 00 = 230Hz 01 = 300Hz 10 = 385Hz 11 = 500Hz
	8	EQ2BW	0	Band 2 Bandwidth Control 0 = narrow bandwidth 1 = wide bandwidth

Table 27 EQ Band 2 Control

REGISTER ADDRESS	BIT	LABEL	DEFAULT	DESCRIPTION
R20 (14h) EQ Band 3 Control	4:0	EQ3G	01100 (0dB)	Band 3 Gain Control. See Table 31 for details.
	6:5	EQ3C	01	Band 3 Centre Frequency: 00 = 650Hz 01 = 850Hz 10 = 1.1kHz 11 = 1.4kHz
	8	EQ3BW	0	Band 3 Bandwidth Control 0 = narrow bandwidth 1 = wide bandwidth

Table 28 EQ Band 3 Control

REGISTER ADDRESS	BIT	LABEL	DEFAULT	DESCRIPTION
R21 (15h) EQ Band 4 Control	4:0	EQ4G	01100 (0dB)	Band 4 Gain Control. See Table 31 for details
	6:5	EQ4C	01	Band 4 Centre Frequency: 00 = 1.8kHz 01 = 2.4kHz 10 = 3.2kHz 11 = 4.1kHz
	8	EQ4BW	0	Band 4 Bandwidth Control 0 = narrow bandwidth 1 = wide bandwidth

Table 29 EQ Band 4 Control

REGISTER ADDRESS	BIT	LABEL	DEFAULT	DESCRIPTION
R22 (16h) EQ Band 5 Gain Control	4:0	EQ5G	01100 (0dB)	Band 5 Gain Control. See Table 31 for details.
	6:5	EQ5C	01	Band 5 Cut-off Frequency: 00 = 5.3kHz 01 = 6.9kHz 10 = 9kHz 11 = 11.7kHz

Table 30 EQ Band 5 Control

GAIN REGISTER	GAIN
00000	+12dB
00001	+11dB
00010	+10dB
.... (1dB steps)	
01100	0dB
01101	-1dB
11000	-12dB
11001 to 11111	Reserved

Table 31 Gain Register Table

See also Figure 46 to Figure 63 for equaliser and high pass filter filter responses.

### 3D STEREO ENHANCEMENT

The WM8985 has a digital 3D enhancement option to increase the perceived separation between the left and right channels. Selection of 3D for record or playback is controlled by register bit EQ3DMODE. Switching this bit from record to playback or from playback to record may only be done when both ADCs and both DACs are disabled.

The DEPTH3D setting controls the degree of stereo expansion.

REGISTER ADDRESS	BIT	LABEL	DEFAULT	DESCRIPTION
R41 (29h) 3D Control	3:0	DEPTH3D	0000	Stereo depth 0000 = Disabled 0001 = 6.67% 0010 = 13.3% 0011 = 20% 0100 = 26.7% 0101 = 33.3% 0110 = 40% 0111 = 46.6% 1000 = 53.3% 1001 = 60% 1010 = 66.7% 1011 = 73.3% 1100 = 80% 1101 = 86.7% 1110 = 93.3% 1111 = 100% (maximum 3D effect)

**Table 32 3D Stereo Enhancement Function**

**Note:** When 3D enhancement is used, it may be necessary to attenuate the signal by 6dB to avoid limiting.

### ANALOGUE OUTPUTS

The WM8985 has three sets of stereo analogue outputs. These are:

- LOUT1 and ROUT1 which are normally used to drive a headphone load.
- LOUT2 and ROUT2 – which can be used as class D or class AB headphone drivers.
- OUT3 and OUT4 – can be configured as a stereo line out (OUT3 is left output and OUT4 is right output) or a differential output. OUT4 can also be used to provide a mono mix of left and right channels.

The outputs LOUT2 and ROUT2 are powered from AVDD2 and are capable of driving a 1V rms signal (AVDD1/3.3).

LOUT1, ROUT1, OUT3 and OUT4 are powered from AVDD1

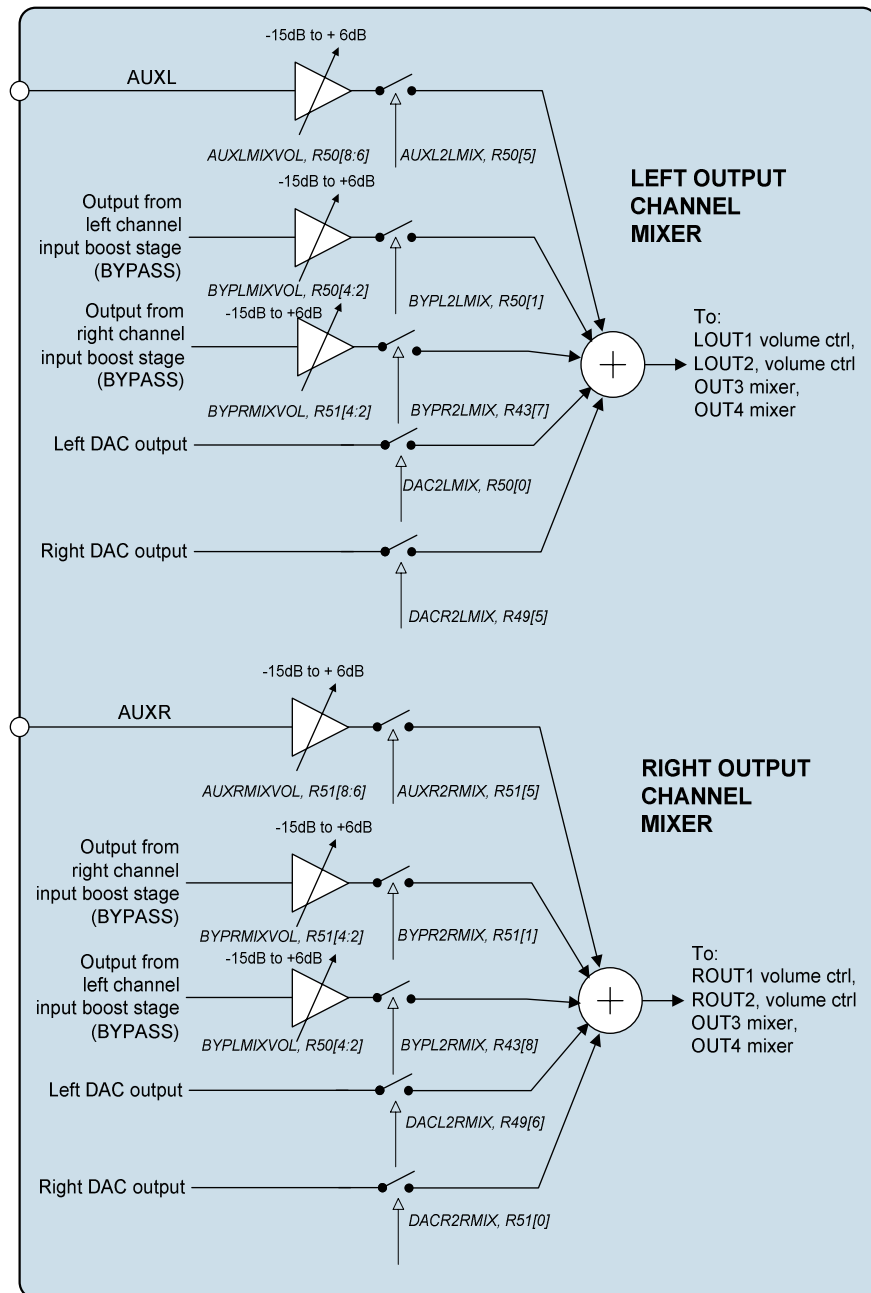
LOUT1, ROUT1, LOUT2 and ROUT2 have individual analogue volume PGAs with -57dB to +6dB gain ranges.

There are four output mixers in the output signal path, the left and right channel mixers which control the signals to headphone (and optionally the line outputs) and also dedicated OUT3 and OUT4 mixers.

**LEFT AND RIGHT OUTPUT CHANNEL MIXERS**

The left and right output channel mixers are shown in Figure 25. These mixers allow the AUX inputs, the ADC bypass and the DAC left and right channels to be combined as desired. This allows a mono mix of the DAC channels to be performed as well as mixing in external line-in from the AUX or speech from the input bypass path.

The AUX and bypass inputs have individual volume control from -15dB to +6dB and the DAC volume can be adjusted in the digital domain if required. The output of these mixers is connected to both the headphone (LOUT1 and ROUT1) and class D headphone (LOUT2 and ROUT2) and can optionally be connected to the OUT3 and OUT4 mixers.



**Figure 25 Left/Right Output Channel Mixers**

REGISTER ADDRESS	BIT	LABEL	DEFAULT	DESCRIPTION
R43 (2Bh) Output mixer control	8	BYPL2RMIX	0	Left bypass path (from the Left channel input PGA stage) to right output mixer 0 = not selected 1 = selected
R43 (2Bh) Output mixer control	7	BYPR2LMIX	0	Right bypass path (from the right channel input PGA stage) to Left output mixer 0 = not selected 1 = selected
R49 (31h) Output mixer control	5	DACR2LMIX	0	Right DAC output to left output mixer 0 = not selected 1 = selected
	6	DACL2RMIX	0	Left DAC output to right output mixer 0 = not selected 1 = selected
R50 (32h) Left channel output mixer control	0	DACL2LMIX	1	Left DAC output to left output mixer 0 = not selected 1 = selected
	1	BYPL2LMIX	0	Left bypass path (from the left channel input PGA stage) to left output mixer 0 = not selected 1 = selected
	4:2	BYPLMIXVOL	000	Left bypass volume control to output channel mixer: 000 = -15dB 001 = -12dB 010 = -9dB 011 = -6dB 100 = -3dB 101 = 0dB 110 = +3dB 111 = +6dB
	5	AUXL2LMIX	0	Left Auxiliary input to left channel output mixer: 0 = not selected 1 = selected
	8:6	AUXLMIXVOL	000	Aux left channel input to left mixer volume control: 000 = -15dB 001 = -12dB 010 = -9dB 011 = -6dB 100 = -3dB 101 = 0dB 110 = +3dB 111 = +6dB

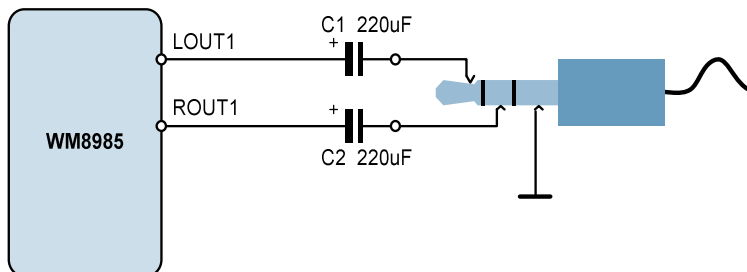
R51 (33h) Right channel output mixer control	0	DACR2RMIX	1	Right DAC output to right output mixer 0 = not selected 1 = selected
	1	BYPR2RMIX	0	Right bypass path (from the right channel input PGA stage) to right output mixer 0 = not selected 1 = selected
	4:2	BYPRMIXVOL	000	Right bypass volume control to output channel mixer: 000 = -15dB 001 = -12dB 010 = -9dB 011 = -6dB 100 = -3dB 101 = 0dB 110 = +3dB 111 = +6dB
	5	AUXR2RMIX	0	Right Auxiliary input to right channel output mixer: 0 = not selected 1 = selected
	8:6	AUXRMIXVOL	000	Aux right channel input to right mixer volume control: 000 = -15dB 001 = -12dB 010 = -9dB 011 = -6dB 100 = -3dB 101 = 0dB 110 = +3dB 111 = +6dB
R3 (03h) Power management 3	2	LMIXEN	0	Left output channel mixer enable: 0 = disabled 1 = enabled
	3	RMIXEN	0	Right output channel mixer enable: 0 = disabled 1 = enabled

Table 33 Left and Right Output Mixer Control

**HEADPHONE OUTPUTS (LOUT1 AND ROUT1)**

The headphone outputs LOUT1 and ROUT1 can drive a 16Ω or 32Ω headphone load, either through DC blocking capacitors, or DC-coupled to a buffered midrail reference (LOUT2 or ROUT2), saving a capacitor (capless mode). When using capless mode AVDD1 and AVDD2 should use the same supply to maximise supply rejection. OUT3 and OUT4 should not be used as a buffered midrail reference in capless mode.

## Headphone Output using DC Blocking Capacitors



## DC Coupled Headphone Output

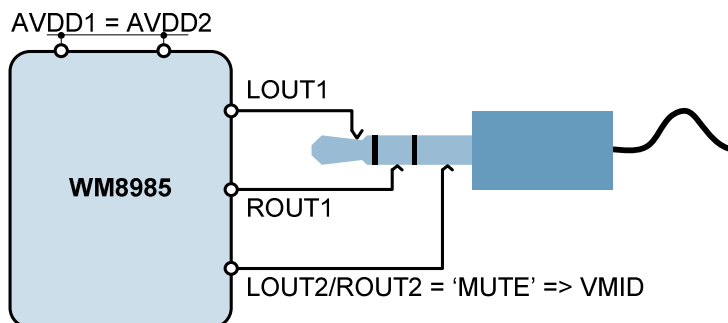


Figure 26 Recommended Headphone Output Configurations

When DC blocking capacitors are used, their capacitance and the load resistance together determine the lower cut-off frequency of the output signal,  $f_c$ . Increasing the capacitance lowers  $f_c$ , improving the bass response. Smaller capacitance values will diminish the bass response. Assuming a  $16\Omega$  load and  $C_1, C_2 = 220\mu\text{F}$ :

$$f_c = 1 / 2\pi R_L C_1 = 1 / (2\pi \times 16\Omega \times 220\mu\text{F}) = 45 \text{ Hz}$$

In the DC coupled configuration, the headphone pseudo-ground is connected to the buffered midrail reference pin (LOUT2 or ROUT2). The L/ROUT2 pins can be configured as a DC output driver by setting the LOUT2MUTE and ROUT2MUTE register bits. The DC voltage on VMID in this configuration is equal to the DC offset on the LOUT1 and ROUT1 pins therefore no DC blocking capacitors are required. This saves space and material cost in portable applications.

It is not recommended to use DC-coupling to line inputs of another device. Although the built-in short circuit protection on the headphone outputs would be tolerant of shorts to ground, such a connection could be noisy, and may not function properly if the other device is grounded. DC-coupled configurations should only be used with headphones.

REGISTER ADDRESS	BIT	LABEL	DEFAULT	DESCRIPTION
R52 (34h) LOUT1 Volume control	5:0	LOUT1VOL	111001 (0dB)	Left headphone output volume: (1dB steps) 000000 = -57dB ... 111001 = 0dB ... 111111 = +6dB
	6	LOUT1MUTE	0	Left headphone output mute: 0 = Normal operation 1 = Mute
	7	LOUT1ZC	0	Headphone volume zero cross enable: 1 = Change gain on zero cross only 0 = Change gain immediately
	8	HPVU	Not latched	LOUT1 and ROUT1 volumes do not update until a 1 is written to HPVU (in reg 52 or 53)
R53 ROUT1 Volume control	5:0	ROUT1VOL	111001 (0dB)	Right headphone output volume: (1dB steps) 000000 = -57dB ... 111001 = 0dB ... 111111 = +6dB
	6	ROUT1MUTE	0	Right headphone output mute: 0 = Normal operation 1 = Mute
	7	ROUT1ZC	0	Headphone volume zero cross enable: 1 = Change gain on zero cross only 0 = Change gain immediately
	8	HPVU	Not latched	LOUT1 and ROUT1 volumes do not update until a 1 is written to HPVU (in reg 52 or 53)

Table 34 OUT1 Volume Control

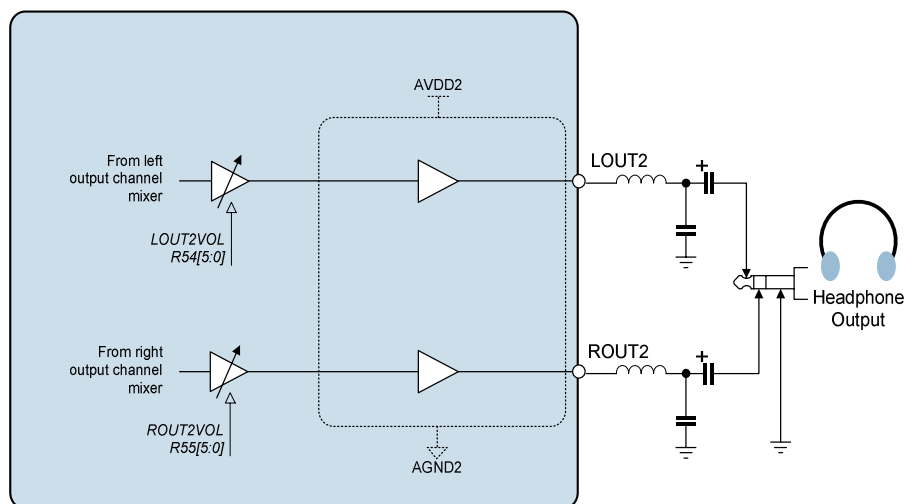
**CLASS D / CLASS AB HEADPHONE OUTPUTS (LOUT2 AND ROUT2)**

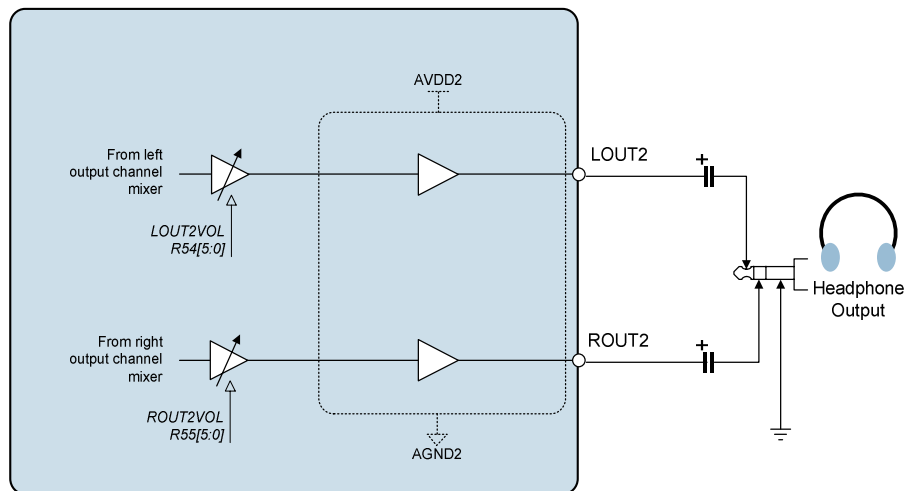
The outputs LOUT2 and ROUT2 are designed to drive two headphone loads of 16Ω or 32Ω or line outputs (See Headphone Output and Line Output sections, respectively). Each output has an individual volume control PGA, a mute and an enable control bit as shown in Figure 27. LOUT2 and ROUT2 output the left and right channel mixer outputs respectively.

REGISTER ADDRESS	BIT	LABEL	DEFAULT	DESCRIPTION
R7 (07h)	7:4	DCLKDIV	1000	Controls clock division from SYSCLK to generate suitable class D clock. Recommended class D clock frequency = 1.4MHz. 0000 = divide by 1 0010 = divide by 2 0011 = divide by 3 0100 = divide by 4 0101 = divide by 5.5 0110 = divide by 6 1000 = divide by 8 1001 = divide by 12 1010 = divide by 16
R23 (17h)	8	CLASSDEN	0	Enable signal for class D mode on LOUT2 and ROUT2 0 = Class AB mode 1 = Class D mode

**Table 35 Class D Control Registers**

When driving headphones using class D outputs it is necessary to use appropriate filtering, placed close to the device, to minimise EMI emissions from the headphone cable (Refer to "Applications Information" for more information). This filtering does not prevent class AB mode operation.

**Figure 27 LOUT2 and ROUT2 Class D Headphone Configuration**



**Figure 28 LOUT2 and ROUT2 Class AB Headphone Configuration**

The output configurations shown in figures 29 and 30 are both suitable for class AB operation.

The signal output on LOUT2/ROUT2 comes from the Left/Right Mixer circuits and can be any combination of the DAC output, the bypass path (output of the input boost stage) and the AUX input. The LOUT2/ROUT2 volume is controlled by the LOUT2VOL/ ROUT2VOL register bits. Gains over 0dB may cause clipping if the input signal is too high. The LOUT2MUTE/ ROUT2MUTE register bits cause these outputs to be muted (the output DC level is driven out). The output pins remain at the same DC level, so that no click noise is produced when muting or un-muting.

REGISTER ADDRESS	BIT	LABEL	DEFAULT	DESCRIPTION
R54 (36h) LOUT2 Volume control	5:0	LOUT2VOL	111001	Left output volume: (1dB steps) 000000 = -57dB ... 111001 = 0dB ... 111111 = +6dB
	6	LOUT2MUTE	0	Left output mute: 0 = Normal operation 1 = Mute
	7	LOUT2ZC	0	LOUT2 volume zero cross enable: 1 = Change gain on zero cross only 0 = Change gain immediately
	8	OUT2VU	Not latched	LOUT2 and ROUT2 volumes do not update until a 1 is written to SPKVU (in reg 54 or 55)
R55 (37h) ROUT2 Volume control	5:0	ROUT2VOL	111001	Right output volume: (1dB steps) 000000 = -57dB ... 111001 = 0dB ... 111111 = +6dB
	6	ROUT2MUTE	0	Right output mute: 0 = Normal operation 1 = Mute
	7	ROUT2ZC	0	ROUT2 volume zero cross enable: 1 = Change gain on zero cross only 0 = Change gain immediately
	8	OUT2VU	Not latched	LOUT2 and ROUT2 volumes do not update until a 1 is written to SPKVU (in reg 54 or 55)

Table 36 OUT2 Volume Control

### ZERO CROSS TIMEOUT

A zero-cross timeout function is provided so that if zero cross is enabled on the input or output PGAs the gain will automatically update after a timeout period if a zero cross has not occurred. This is enabled by setting SLOWCLKEN. The timeout period is dependent on the clock input to the digital and is equal to  $2^{21} \cdot \text{SYSCLK period}$ .

REGISTER ADDRESS	BIT	LABEL	DEFAULT	DESCRIPTION
R7 (07h) Additional Control	0	SLOWCLKEN	0	Slow clock enable 0 = slow clock disabled 1 = slow clock enabled

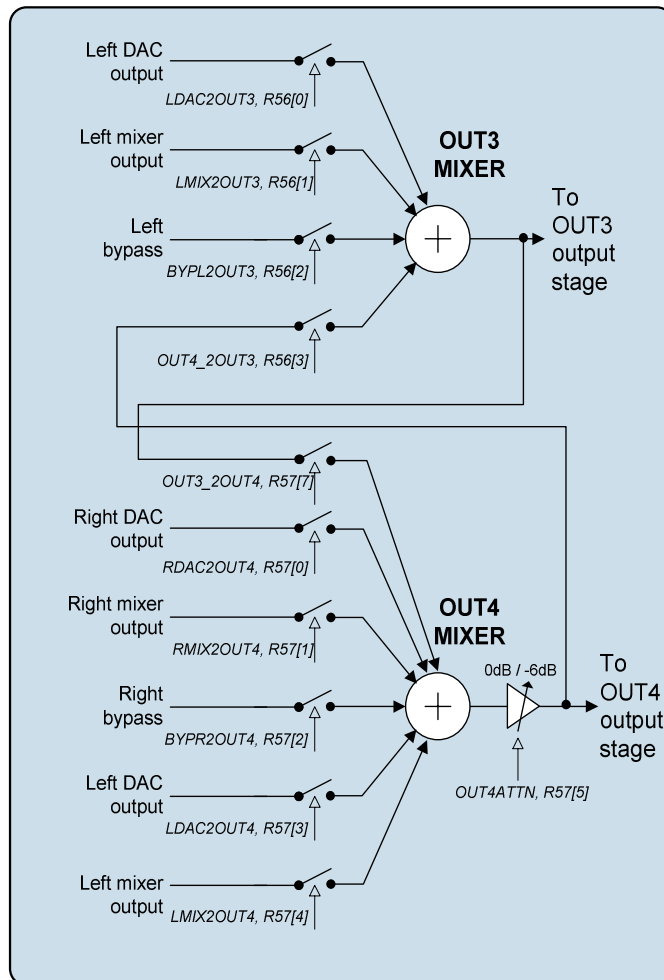
Table 37 Timeout Clock Enable Control

**Note:** SLOWCLKEN is also used for the jack insert detect debounce circuit

### OUT3/OUT4 MIXERS AND OUTPUT STAGES

The OUT3/OUT4 pins provide an additional stereo line output, a mono output, or a differential output. There is a dedicated analogue mixer for OUT3 and one for OUT4 as shown in Figure 29.

The OUT3 and OUT4 output stages are powered from AVDD1 and AGND1.



**Figure 29** OUT3 and OUT4 Mixers

OUT3 can provide a left line output, or a mono mix line output.

OUT4 can provide a right line output, or a mono mix line output.

A 6dB attenuation function is provided for OUT4, to prevent clipping during mixing of left and right signals. This function is enabled by the OUT4ATTN register bit.

REGISTER ADDRESS	BIT	LABEL	DEFAULT	DESCRIPTION
R56 (38h) OUT3 mixer control	6	OUT3MUTE	0	0 = Output stage outputs OUT3 mixer 1 = Output stage muted – drives out VMID. Can be used as VMID reference in this mode.
	3	OUT4_2OUT3	0	OUT4 mixer output to OUT3 0 = disabled 1 = enabled
	2	BYPL2OUT3	0	Left ADC input to OUT3 0 = disabled 1 = enabled
	1	LMIX2OUT3	0	Left DAC mixer to OUT3 0 = disabled 1 = enabled
	0	LDAC2OUT3	1	Left DAC output to OUT3 0 = disabled 1 = enabled
R57 (39h) OUT4 mixer control	7	OUT3_2OUT4	0	OUT3 mixer output to OUT4 0 = disabled 1 = enabled
	6	OUT4MUTE	0	0 = Output stage outputs OUT4 mixer 1 = Output stage muted – drives out VMID. Can be used as VMID reference in this mode.
	5	OUT4ATTN	0	0 = OUT4 normal output 1 = OUT4 attenuated by 6dB
	4	LMIX2OUT4	0	Left DAC mixer to OUT4 0 = disabled 1 = enabled
	3	LDAC2OUT4	0	Left DAC to OUT4 0 = disabled 1 = enabled
	2	BYPR2OUT4	0	Right ADC input to OUT4 0 = disabled 1 = enabled
	1	RMIX2OUT4	0	Right DAC mixer to OUT4 0 = disabled 1 = enabled
	0	RDAC2OUT4	1	Right DAC output to OUT4 0 = disabled 1 = enabled

Table 38 OUT3/OUT4 Mixer Registers

### ENABLING THE OUTPUTS

Each analogue output of the WM8985 can be independently enabled or disabled. The analogue mixer associated with each output has a separate enable bit. All outputs are disabled by default. To save power, unused parts of the WM8985 should remain disabled.

Outputs can be enabled at any time, but it is not recommended to do so when BUFIO is disabled (BUFIOEN=0), as this may cause pop noise (see “Power Management” and “Applications Information” sections).

REGISTER ADDRESS	BIT	LABEL	DEFAULT	DESCRIPTION
R1 (01h) Power Management 1	2	BUFIOEN	0	Unused input/output bias buffer enable
	6	OUT3MIXEN	0	OUT3 mixer enable
	7	OUT4MIXEN	0	OUT4 mixer enable
R2 (02h) Power Management 2	8	ROUT1EN	0	ROUT1 output enable
	7	LOUT1EN	0	LOUT1 output enable
	6	SLEEP	0	0 = Normal device operation 1 = Supply current reduced in device standby mode when clock supplied
R3 (03h) Power Management 3	2	LMIXEN	0	Left mixer enable
	3	RMIXEN	0	Right mixer enable
	5	LOUT2EN	0	LOUT2 output enable
	6	ROUT2EN	0	ROUT2 output enable
	7	OUT3EN	0	OUT3 enable
	8	OUT4EN	0	OUT4 enable

**Note:** All “Enable” bits are 1 = ON, 0 = OFF

**Table 39 Output Stages Power Management Control**

### THERMAL SHUTDOWN

To protect the WM8985 from becoming too hot, a thermal sensor has been built in. If the device junction temperature reaches approximately 125°C and the TSDEN and TSOPCTRL bit are set, then all outputs will be disabled to avoid further increase of the chip temperature.

Additionally, when the device is too hot and TSDEN is set, then the WM8985 de-asserts GPIO bit 11, a virtual GPIO that can be set up to generate an interrupt to the CPU (see “GPIO and Interrupt Control” section).

REGISTER ADDRESS	BIT	LABEL	DEFAULT	DESCRIPTION
R49 (31h) Output Control	1	TSDEN	0	Thermal Sensor Enable 0 = disabled 1 = enabled
	2	TSOPCTRL	0	Thermal Shutdown Output enable 0 = Disabled 1 = Enabled, i.e. all outputs will be disabled if T1 set and the device junction temperature is more than 125°C.

**Table 40 Thermal Shutdown**

### UNUSED ANALOGUE INPUTS/OUTPUTS

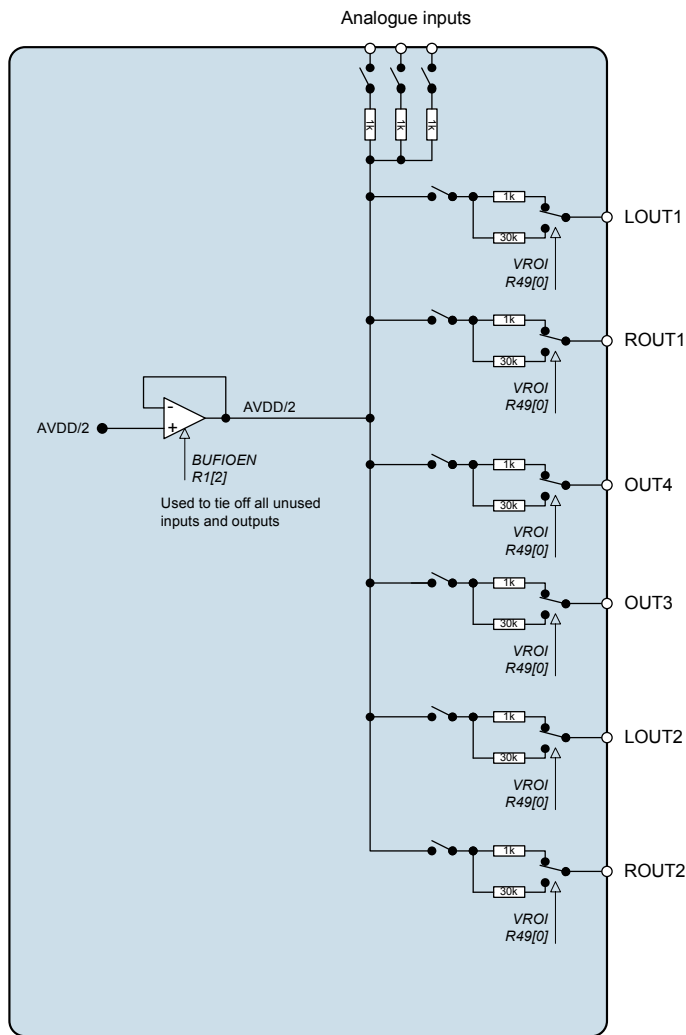
Whenever an analogue input/output is disabled, it remains connected to a voltage source (AVDD1/2) through a resistor. This helps to prevent pop noise when the output is re-enabled. The resistance between the voltage buffer and the output pins can be controlled using the VROI control bit. The default impedance is low, so that any capacitors on the outputs can charge up quickly at start-up. If a high impedance is desired for disabled outputs, VROI can then be set to 1, increasing the resistance to about 30kΩ.

REGISTER ADDRESS	BIT	LABEL	DEFAULT	DESCRIPTION
R49 (31h)	0	VROI	0	VREF (AVDD1/2) to analogue output resistance 0 = approx 1kΩ 1 = approx 30 kΩ

**Table 41 Disabled Outputs to VREF Resistance**

A dedicated buffer is available for biasing unused analogue I/O pins as shown in Figure 30. This buffer can be enabled using the BUFIOEN register bit.

Figure 30 summarises the bias options for the output pins.



**Figure 30 Unused Input/Output Pin Tie-off Buffers**

L/ROUT2EN/ OUT3/4EN	VROI	OUTPUT CONFIGURATION
0	0	1kΩ to AVDD1/2
0	1	30kΩ to AVDD1/2
1	X	Output enabled (DC level=AVDD1/2)

**Table 42 Unused Output Pin Bias Options**

## DIGITAL AUDIO INTERFACES

The audio interface has four pins:

- ADCDAT: ADC data output
- DACDAT: DAC data input
- LRC: Data Left/Right alignment clock
- BCLK: Bit clock, for synchronisation

The clock signals BCLK, and LRC can be outputs when the WM8985 operates as a master, or inputs when it is a slave (see Master and Slave Mode Operation, below).

Five different audio data formats are supported:

- Left justified
- Right justified
- I<sup>2</sup>S
- DSP mode A
- DSP mode B

All of these modes are MSB first. They are described in Audio Data Formats, below. Refer to the Electrical Characteristic section for timing information.

### MASTER AND SLAVE MODE OPERATION

The WM8985 audio interface may be configured as either master or slave. As a master interface device the WM8985 generates BCLK and LRC and thus controls sequencing of the data transfer on ADCDAT and DACDAT. To set the device to master mode register bit MS should be set high. In slave mode (MS=0), the WM8985 responds with data to clocks it receives over the digital audio interfaces.

### AUDIO DATA FORMATS

In Left Justified mode, the MSB is available on the first rising edge of BCLK following an LRC transition. The other bits up to the LSB are then transmitted in order. Depending on word length, BCLK frequency and sample rate, there may be unused BCLK cycles before each LRC transition.

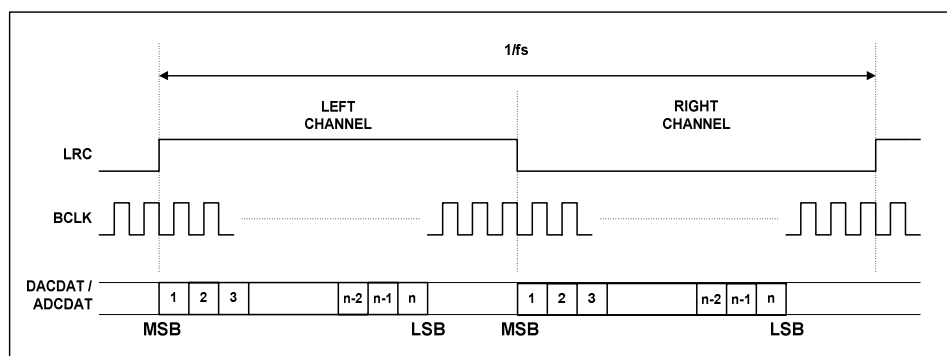


Figure 31 Left Justified Audio Interface (assuming n-bit word length)

In Right Justified mode, the LSB is available on the last rising edge of BCLK before a LRC transition. All other bits are transmitted before (MSB first). Depending on word length, BCLK frequency and sample rate, there may be unused BCLK cycles after each LRC transition.

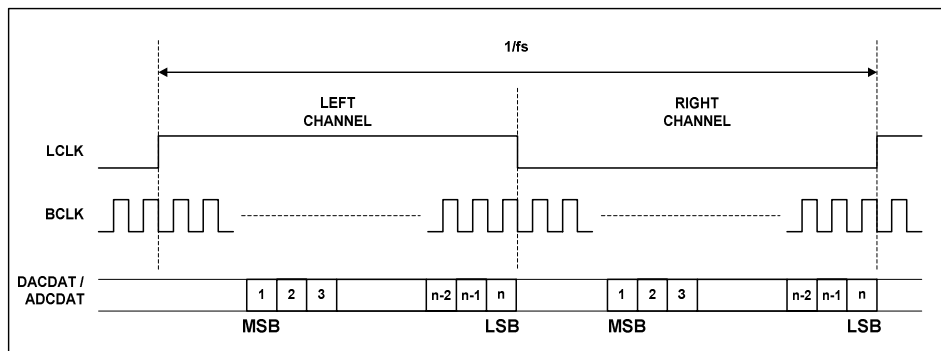


Figure 32 Right Justified Audio Interface (assuming n-bit word length)

In  $I^2S$  mode, the MSB is available on the second rising edge of BCLK following a LRC transition. The other bits up to the LSB are then transmitted in order. Depending on word length, BCLK frequency and sample rate, there may be unused BCLK cycles between the LSB of one sample and the MSB of the next.

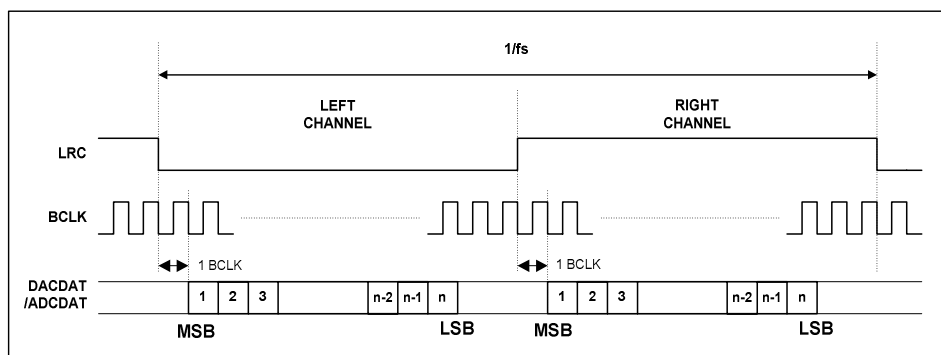


Figure 33  $I^2S$  Audio Interface (assuming n-bit word length)

In DSP/PCM mode, the left channel MSB is available on either the 1<sup>st</sup> (mode B) or 2<sup>nd</sup> (mode A) rising edge of BCLK (selectable by LRP) following a rising edge of LRC. Right channel data immediately follows left channel data. Depending on word length, BCLK frequency and sample rate, there may be unused BCLK cycles between the LSB of the right channel data and the next sample.

In device master mode, the LRC output will resemble the LRC pulse shown in Figure 34 and Figure 35. In device slave mode, Figure 36 and Figure 37, it is possible to use any length of LRC pulse less than 1/fs, providing the falling edge of the LRC pulse occurs greater than one BCLK period before the rising edge of the next LRC pulse.

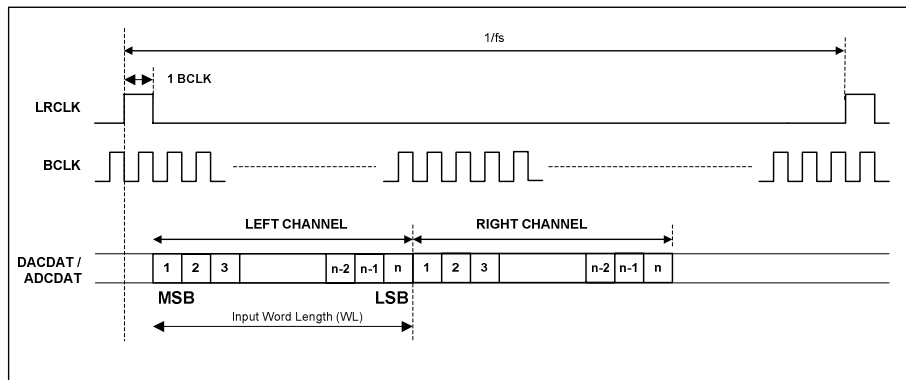


Figure 34 DSP/PCM Mode Audio Interface (mode A, LRP=0, Master)

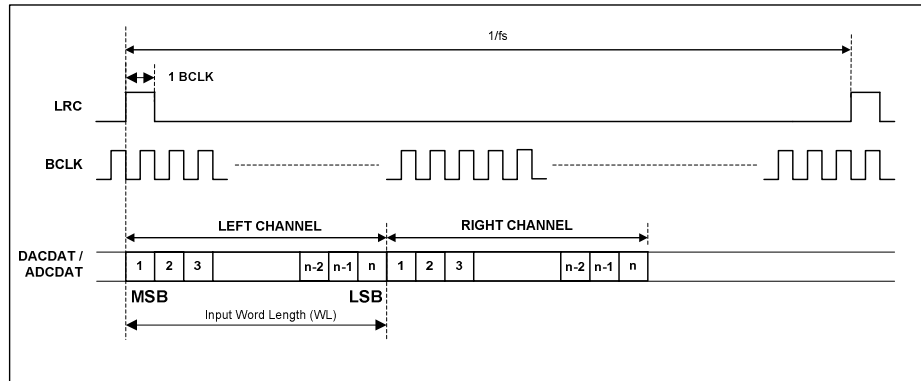


Figure 35 DSP/PCM Mode Audio Interface (mode B, LRP=1, Master)

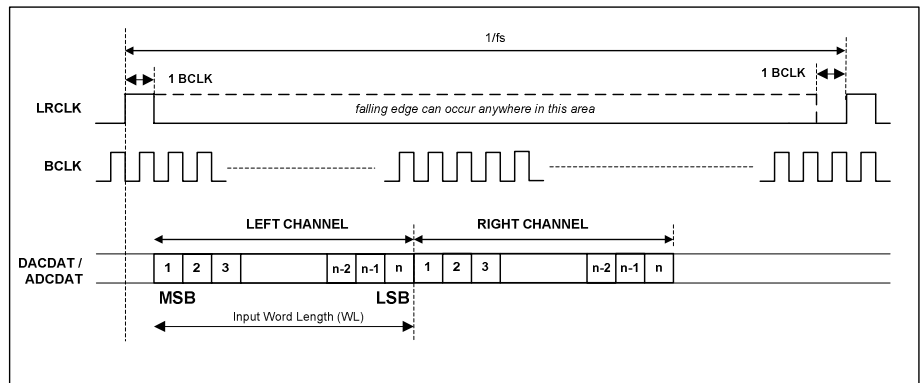


Figure 36 DSP/PCM Mode Audio Interface (mode A, LRP=0, Slave)

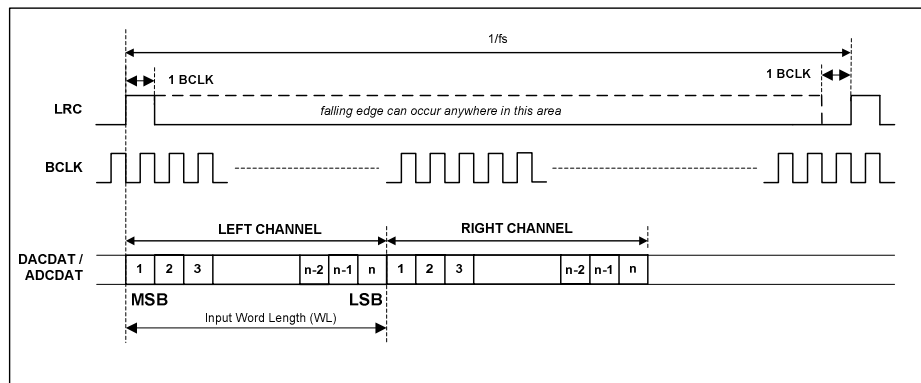


Figure 37 DSP/PCM Mode Audio Interface (mode B, LRP=0, Slave)

REGISTER ADDRESS	BIT	LABEL	DEFAULT	DESCRIPTION
R4 (04h) Audio Interface Control	0	MONO	0	Selects between stereo and mono device operation: 0 = Stereo device operation 1 = Mono device operation. Data appears in 'left' phase of LRC only.
	1	ALRSWAP	0	Controls whether ADC data appears in 'right' or 'left' phases of LRC clock: 0 = ADC left data appear in 'left' phase of LRC and right data in 'right' phase 1 = ADC left data appear in 'right' phase of LRC and right data in 'left' phase
	2	DLRSWAP	0	Controls whether DAC data appears in 'right' or 'left' phases of LRC clock: 0 = DAC left data appear in 'left' phase of LRC and right data in 'right' phase 1 = DAC left data appear in 'right' phase of LRC and right data in 'left' phase
	4:3	FMT	10	Audio interface Data Format Select: 00 = Right Justified 01 = Left Justified 10 = I <sup>2</sup> S format 11 = DSP/PCM mode
	6:5	WL	10	Word length 00 = 16 bits 01 = 20 bits 10 = 24 bits 11 = 32 bits (see note)
	7	LRP	0	LRC clock polarity 0 = normal 1 = inverted  DSP Mode – mode A/B select 0 = MSB is available on 2 <sup>nd</sup> BCLK rising edge after LRC rising edge (mode A) 1 = MSB is available on 1 <sup>st</sup> BCLK rising edge after LRC rising edge (mode B)
	8	BCP	0	BCLK polarity 0 = normal 1 = inverted
R5	0	LOOPBACK	0	Digital loopback function 0 = No loopback 1 = Loopback enabled, ADC data output is fed directly into DAC data input.

Table 43 Audio Interface Control

**Note:** Right Justified Mode will only operate with a maximum of 24 bits. If 32-bit mode is selected the device will operate in 24-bit mode.

#### AUDIO INTERFACE CONTROL

The register bits controlling audio format, word length and master / slave mode are summarised below.

Register bit MS selects audio interface operation in master or slave mode. In Master mode BCLK, and LRC are outputs. The frequency of BCLK in master mode can be controlled with BCLKDIV. The frequencies of BCLK and LRC are also controlled by MCLKDIV. The LRC sample rate is set to the required values by MCLKDIV and the BCLK rate will be set accordingly to provide sufficient BCLKs for that chosen sample rate. These clocks are divided down versions of master clock.

REGISTER ADDRESS	BIT	LABEL	DEFAULT	DESCRIPTION
R6 (06h) Clock Generation Control	0	MS	0	Sets the chip to be master over LRC and BCLK 0 = BCLK and LRC clock are inputs 1 = BCLK and LRC clock are outputs generated by the WM8985 (MASTER)
	4:2	BCLKDIV	000	Configures the BCLK output frequency, for use when the chip is master over BCLK. 000 = divide by 1 (BCLK=SYSCLK) 001 = divide by 2 (BCLK=SYSCLK/2) 010 = divide by 4 (BCLK=SYSCLK/4) 011 = divide by 8 (BCLK=SYSCLK/8) 100 = divide by 16 (BCLK=SYSCLK/16) 101 = divide by 32 (BCLK=SYSCLK/32) 110 = reserved 111 = reserved
	7:5	MCLKDIV	010	Sets the scaling for SYSCLK clock output (under control of CLKSEL) 000 = divide by 1 (LRC=SYSCLK/128) 001 = divide by 1.5 (LRC=SYSCLK/192) 010 = divide by 2 (LRC=SYSCLK/256) 011 = divide by 3 (LRC=SYSCLK/384) 100 = divide by 4 (LRC=SYSCLK/512) 101 = divide by 6 (LRC=SYSCLK/768) 110 = divide by 8 (LRC=SYSCLK/1024) 111 = divide by 12 (LRC=SYSCLK/1536)
	8	CLKSEL	1	Controls the source of the clock for all internal operation: 0 = MCLK 1 = PLL output

Table 44 Clock Control

## AUDIO SAMPLE RATES

The WM8985 ADC high pass filter, ALC and DAC limiter characteristics are sample rate dependent. SR should be set to the correct sample rate or the closest value if the actual sample rate is not available.

If a sample rate that is not explicitly supported by the SR register settings is required then the closest SR value to that sample rate should be chosen. The filter characteristics and the ALC attack decay and hold times will scale appropriately.

REGISTER ADDRESS	BIT	LABEL	DEFAULT	DESCRIPTION
R7 (07h) Additional Control	3:1	SR	000	Approximate sample rate (configures the coefficients for the internal digital filters): 000 = 48kHz 001 = 32kHz 010 = 24kHz 011 = 16kHz 100 = 12kHz 101 = 8kHz 110-111 = reserved

Table 45 Sample Rate Control

### MASTER CLOCK AND PHASE LOCKED LOOP (PLL)

The WM8985 has an on-chip phase-locked loop (PLL) circuit that can be used to:

Generate master clocks for the WM8985 audio functions from another external clock, e.g. in telecoms applications.

Generate and output (on pin CSB/GPIO1) a clock for another part of the system that is derived from an existing audio master clock.

Figure shows the PLL and internal clocking on the WM8985.

The PLL can be enabled or disabled by the PLEN register bit.

REGISTER ADDRESS	BIT	LABEL	DEFAULT	DESCRIPTION
R1 (01h) Power management 1	5	PLEN	0	PLL enable 0 = PLL off 1 = PLL on

Table 46 PLEN Control Bit

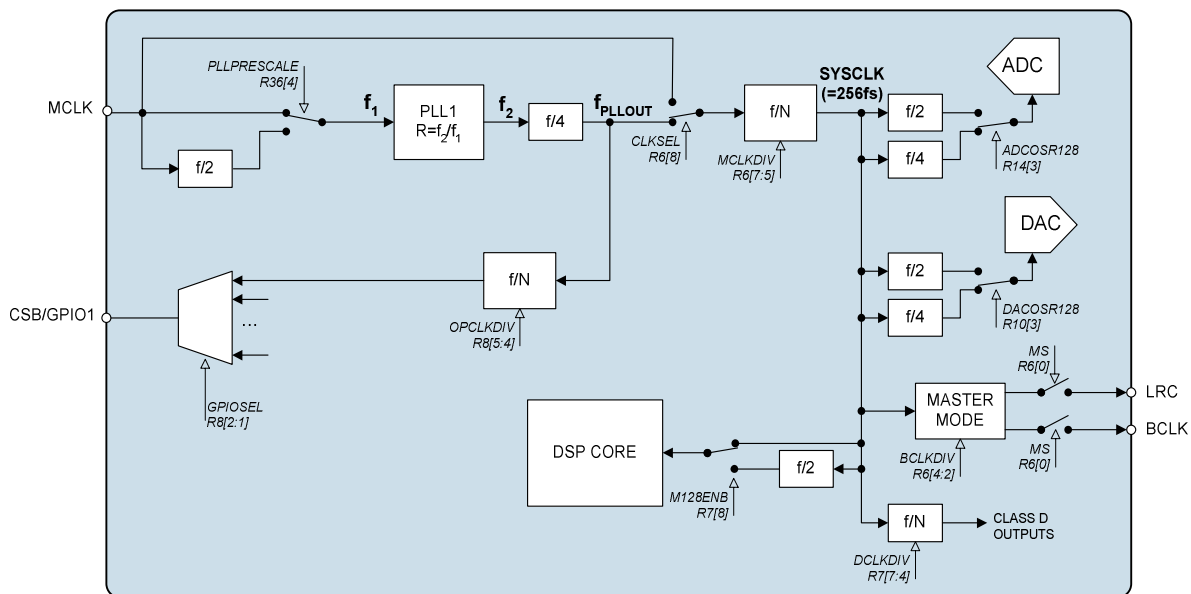


Figure 38 PLL and Clock Select Circuit

The PLL frequency ratio  $R = f_2/f_1$  (see Figure ) can be set using the register bits PLLK and PLLN:

$$PLL N = \text{int } R$$

$$PLL K = \text{int } (2^{24} (R - PLLN))$$

**EXAMPLE:**

MCLK=12MHz, required clock = 12.288MHz.

R should be chosen to ensure  $5 < PLLN < 13$ . There is a fixed divide by 4 in the PLL and a selectable divide by N after the PLL which should be set to divide by 2 to meet this requirement.

Enabling the divide by 2 sets the required  $f_2 = 4 \times 2 \times 12.288\text{MHz} = 98.304\text{MHz}$ .

$$R = 98.304 / 12 = 8.192$$

$$PLL N = \text{int } R = 8$$

$$k = \text{int } ( 2^{24} \times (8.192 - 8) ) = 3221225 = 3126\text{E9h}$$

REGISTER ADDRESS	BIT	LABEL	DEFAULT	DESCRIPTION
R36 (24h) PLL N value	4	PLLPRESCALE	0	0 = MCLK input not divided (default) 1 = Divide MCLK by 2 before input to PLL
	3:0	PLLN	1000	Integer (N) part of PLL input/output frequency ratio. Use values greater than 5 and less than 13.
R37 (25h) PLL K value 1	5:0	PLLK [23:18]	0Ch	Fractional (K) part of PLL1 input/output frequency ratio (treat as one 24-digit binary number).
R38 (26h) PLL K Value 2	8:0	PLLK [17:9]	093h	
R39 (27h) PLL K Value 3	8:0	PLLK [8:0]	0E9h	

Table 47 PLL Frequency Ratio Control

The PLL performs best when  $f_2$  is around 90MHz. Its stability peaks at N=8. Some example settings are shown in 48.

MCLK (MHz) (f1)	DESIRED OUTPUT (SYCLK) (MHz)	f2 (MHz)	PLLPRESCALE	MCLKDIV	R	N	K	N REGISTER R36[3:0]	K REGISTERS		
									R37	R38	R39
12	11.29	90.3168	1	2	7.5264	7h	86C226h	XX7h	021h	161h	026h
12	12.288	98.304	1	2	8.192	8h	3126E8h	XX8h	00Ch	093h	0E8h
13	11.29	90.3168	1	2	6.947446	6h	F28BD4h	XX6h	03Ch	145h	1D4h
13	12.288	98.304	1	2	7.561846	7h	8FD525h	XX7h	023h	1EAh	125h
14.4	11.29	90.3168	1	2	6.272	6h	45A1CAh	XX6h	011h	0D0h	1CAh
14.4	12.288	98.304	1	2	6.826667	6h	D3A06Eh	XX6h	034h	1D0h	06Eh
19.2	11.29	90.3168	2	2	9.408	9h	6872AFh	XX9h	01Ah	039h	0AFh
19.2	12.288	98.304	2	2	10.24	Ah	3D70A3h	XXAh	00Fh	0B8h	0A3h
19.68	11.29	90.3168	2	2	9.178537	9h	2DB492h	XX9h	00Bh	0DAh	092h
19.68	12.288	98.304	2	2	9.990243	9h	FD809Fh	XX9h	03Fh	0C0h	09Fh
19.8	11.29	90.3168	2	2	9.122909	9h	1F76F7h	XX9h	007h	1BBh	0F7h
19.8	12.288	98.304	2	2	9.929697	9h	EE009Eh	XX9h	03Bh	100h	09Eh
24	11.29	90.3168	2	2	7.5264	7h	86C226h	XX7h	021h	161h	026h
24	12.288	98.304	2	2	8.192	8h	3126E8h	XX8h	00Ch	093h	0E8h
26	11.29	90.3168	2	2	6.947446	6h	F28BD4h	XX6h	03Ch	145h	1D4h
26	12.288	98.304	2	2	7.561846	7h	8FD525h	XX7h	023h	1EAh	125h
27	11.29	90.3168	2	2	6.690133	6h	B0AC93h	XX6h	02Ch	056h	093h
27	12.288	98.304	2	2	7.281778	7h	482296h	XX7h	012h	011h	096h

Table 48 PLL Frequency Examples

## LOOPBACK

Setting the LOOPBACK register bit enables digital loopback. When this bit is set the output data from the ADC audio interface is fed directly into the DAC data input.

## COMPANDING

The WM8985 supports A-law and  $\mu$ -law companding on both transmit (ADC) and receive (DAC) sides. Companding can be enabled on the DAC or ADC audio interfaces by writing the appropriate value to the DAC\_COMP or ADC\_COMP register bits respectively.

REGISTER ADDRESS	BIT	LABEL	DEFAULT	DESCRIPTION
R5 (05h) Companding Control	2:1	ADC_COMP	0	ADC companding 00 = off 01 = reserved 10 = $\mu$ -law 11 = A-law
	4:3	DAC_COMP	0	DAC companding 00 = off 01 = reserved 10 = $\mu$ -law 11 = A-law
	5	WL8	0	0 = off 1 = device operates in 8-bit mode.

**Table 49 Companding Control**

Companding involves using a piecewise linear approximation of the following equations (as set out by ITU-T G.711 standard) for data compression:

$\mu$ -law (where  $\mu=255$  for the U.S. and Japan):

$$F(x) = \ln(1 + \mu|x|) / \ln(1 + \mu) \quad -1 \leq x \leq 1$$

Table 58 law (where  $A=87.6$  for Europe):

$$F(x) = A|x| / (1 + \ln A) \quad \text{for } x \leq 1/A$$

$$F(x) = (1 + \ln A|x|) / (1 + \ln A) \quad \text{for } 1/A \leq x \leq 1$$

The companded data is also inverted as recommended by the G.711 standard (all 8 bits are inverted for  $\mu$ -law, all even data bits are inverted for A-law). The data will be transmitted as the first 8 MSB's of data.

Companding converts 13 bits ( $\mu$ -law) or 12 bits (A-law) to 8 bits using non-linear quantization. The input data range is separated into 8 levels, allowing low amplitude signals better precision than that of high amplitude signals. This is to exploit the operation of the human auditory system, where louder sounds do not require as much resolution as quieter sounds. The companded signal is an 8-bit word containing sign (1-bit), exponent (3-bits) and mantissa (4-bits).

Setting the WL8 register bit allows the device to operate with 8-bit data. In this mode it is possible to use 8 BCLK's per LRC frame. When using DSP mode B, this allows 8-bit data words to be output consecutively every 8 BCLK's and can be used with 8-bit data words using the A-law and  $\mu$ -law companding functions.

BIT7	BIT[6:4]	BIT[3:0]
SIGN	EXPONENT	MANTISSA

**Table 50 8-bit Companded Word Composition**

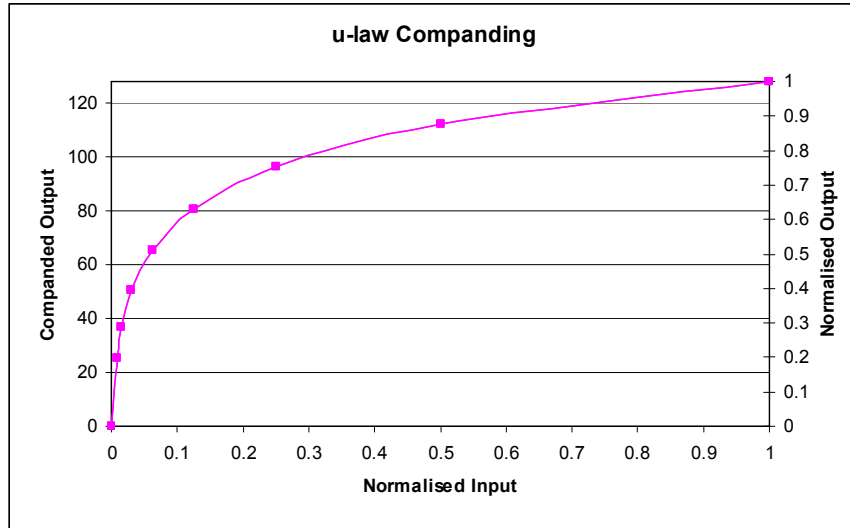
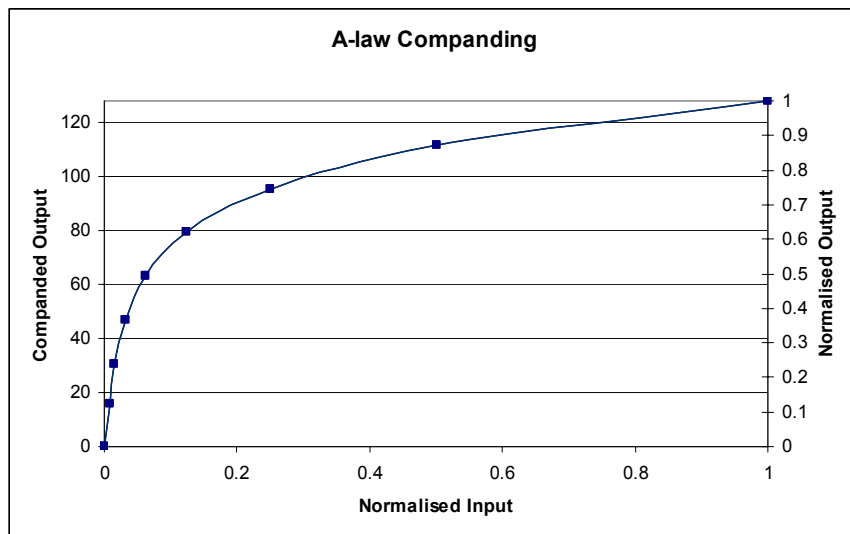
Figure 39  $\mu$ -Law Companding

Figure 40 A-Law Companding

## GENERAL PURPOSE INPUT/OUTPUT

The WM8985 has three dual purpose input/output pins.

- CSB/GPIO1: CSB / GPIO1 pin
- L2/GPIO2: Left channel line input / headphone detection input
- R2/GPIO3: Right channel line input / headphone detection input

The GPIO2 and GPIO3 functions are provided for use as jack detection inputs.

The GPIO1 function is provided for use as jack detection input or general purpose output.

The default configuration for the CSB/GPIO1 is to be an input.

When setup as an input, the CSB/GPIO1 pin can either be used as CSB or for jack detection, depending on how the MODE pin is set.

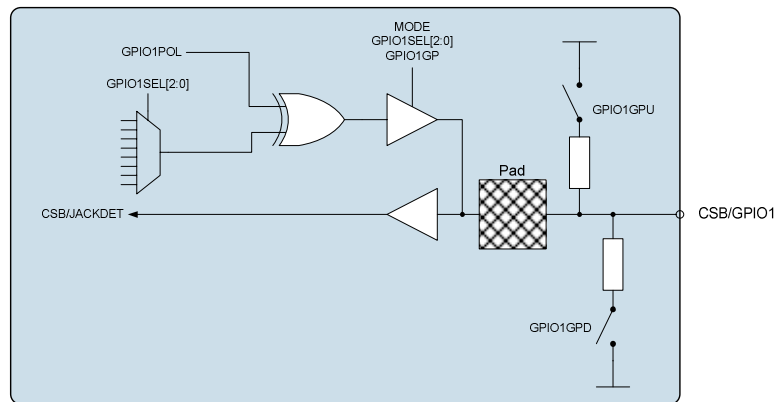
Table 45 illustrates the functionality of the GPIO1 pin when used as a general purpose output.

REGISTER ADDRESS	BIT	LABEL	DEFAULT	DESCRIPTION
R8 (08h) GPIO Control	2:0	GPIO1SEL	000	CSB/GPIO1 pin function select: 000 = input (CSB / Jack detection: depending on MODE setting) 001 = reserved 010 = Temp ok 011 = Amute active 100 = PLL clk output 101 = PLL lock 110 = logic 0 111 = logic 1
	3	GPIO1POL	0	GPIO1 Polarity invert 0 = Non inverted 1 = Inverted
	5:4	OPCLKDIV	00	PLL Output clock division ratio 00 = divide by 1 01 = divide by 2 10 = divide by 3 11 = divide by 4
	6	GPIO1GPD	0	GPIO1 Internal pull-down enable: 0 = Internal pull-down disabled 1 = Internal pull-down enabled
	7	GPIO1GPU	0	GPIO1 Internal pull-up enable: 0 = Internal pull-up disabled 1 = Internal pull-up enabled
	8	GPIO1GP	0	GPIO1 Open drain enable 0 = Open drain disabled 1 = Open drain enabled

**Table 45 CSB/GPIO Control**

**Note:**

If MODE is set to 3 wire mode, CSB/GPIO1 is used as CSB input irrespective of the GPIO1SEL[2:0] bits.



For further details of the jack detect operation see the OUTPUT SWITCHING section.

## OUTPUT SWITCHING (JACK DETECT)

When the device is operated using a 2-wire interface the CSB/GPIO1 pin can be used as a switch control input to automatically disable one set of outputs and enable another; the most common use for this functionality is as jack detect circuitry. The L2/GPIO2 and R2/GPIO3 pins can also be used for this purpose.

The GPIO pins have an internal de-bounce circuit when in this mode in order to prevent the output enables from toggling multiple times due to input glitches. This de-bounce circuit is clocked from a slow clock with period  $2^{21} \times \text{MCLK}$  and is enabled by the SLOWCLKEN bit.

Notes:

1. The SLOWCLKEN bit must be enabled for the jack detect circuitry to operate.
2. The GPIOPOL bit is not relevant for jack detection, it is the signal detected at the pin which is used

Switching on/off of the outputs is fully configurable by the user. Each output, OUT1, OUT2, OUT3 and OUT4 has 2 associated enables. OUT1\_EN\_0, OUT2\_EN\_0, OUT3\_EN\_0 and OUT4\_EN\_0 are the output enable signals which are used if the selected jack detection pin is at logic 0 (after de-bounce). OUT1\_EN\_1, OUT2\_EN\_1, OUT3\_EN\_1 and OUT4\_EN\_1 are the output enable signals which are used if the selected jack detection pin is at logic 1 (after de-bounce).

The jack detection enables operate as follows:

All OUT\_EN signals have an AND function performed with their normal enable signals (in Table 39). When an output is normally enabled at per Table 39, the selected jack detection enable (controlled by selected jack detection pin polarity) is set 0; it will turn the output off. If the normal enable signal is already OFF (0), the jack detection signal will have no effect due to the AND function.

During jack detection if the user desires an output to be un-changed whether the jack is in or not, both the JD\_EN settings, i.e. JD\_EN0 and JD\_EN1, should be set to 0000.

If jack detection is not enabled (JD\_EN=0), the output enables default to all 1's, allowing the outputs to be controlled as normal via the normal output enables found in Table 39.

REGISTER ADDRESS	BIT	LABEL	DEFAULT	DESCRIPTION
R9 (09h) GPIO control	5:4	JD_SEL	00	Pin selected as jack detection input 00 = GPIO1 01 = GPIO2 10 = GPIO3 11 = Reserved
	6	JD_EN	0	Jack Detection Enable 0 = disabled 1 = enabled
R13 (00h)	3:0	JD_EN0	0000	Output enables when selected jack detection input is logic 0. [0]= OUT1_EN_0 [1]= OUT2_EN_0 [2]= OUT3_EN_0 [3]= OUT4_EN_0
	7:4	JD_EN1	0000	Output enables when selected jack detection input is logic 1 [4]= OUT1_EN_1 [5]= OUT2_EN_1 [6]= OUT3_EN_1 [7]= OUT4_EN_1

**Table 46 Jack Detect Register Control Bits**

## CONTROL INTERFACE

### SELECTION OF CONTROL MODE AND 2-WIRE MODE ADDRESS

The control interface can operate as either a 3-wire or 2-wire control interface. The MODE pin determines the 2 or 3 wire mode as shown in Table 47.

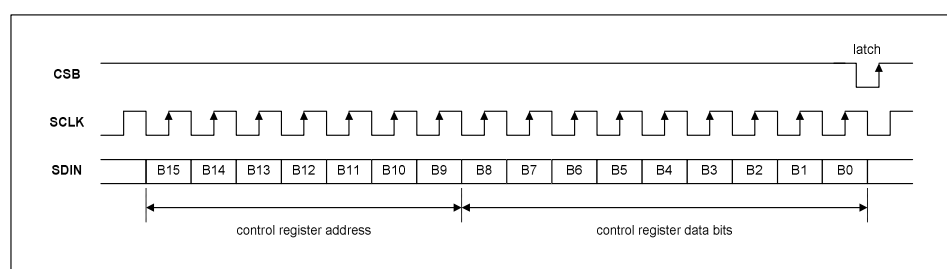
The WM8985 is controlled by writing to registers through a serial control interface. A control word consists of 16 bits. The first 7 bits (B15 to B9) are register address bits that select which control register is accessed. The remaining 9 bits (B8 to B0) are data bits, corresponding to the 9 data bits in each control register.

MODE	INTERFACE FORMAT
Low	2 wire
High	3 wire

**Table 47 Control Interface Mode Selection**

### 3-WIRE SERIAL CONTROL MODE

In 3-wire mode, every rising edge of SCLK clocks in one data bit from the SDIN pin. A rising edge on CSB/GPIO latches in a complete control word consisting of the last 16 bits.



**Figure 38 3-Wire Serial Control Interface**

## 2-WIRE SERIAL CONTROL MODE

The WM8985 supports software control via a 2-wire serial bus. Many devices can be controlled by the same bus, and each device has a unique 7-bit device address (this is not the same as the 7-bit address of each register in the WM8985).

The WM8985 operates as a slave device only. The controller indicates the start of data transfer with a high to low transition on SDIN while SCLK remains high. This indicates that a device address and data will follow. All devices on the 2-wire bus respond to the start condition and shift in the next eight bits on SDIN (7-bit address + Read/Write bit, MSB first). If the device address received matches the address of the WM8985, the WM8985 responds by pulling SDIN low on the next clock pulse (ACK). If the address is not recognised or the R/W bit is '1' when operating in write only mode, the WM8985 returns to the idle condition and waits for a new start condition and valid address.

During a write, once the WM8985 has acknowledged a correct address, the controller sends the first byte of control data (B15 to B8, i.e. the WM8985 register address plus the first bit of register data). The WM8985 then acknowledges the first data byte by driving SDIN low for one clock cycle. The controller then sends the second byte of control data (B7 to B0, i.e. the remaining 8 bits of register data), and the WM8985 acknowledges again by pulling SDIN low.

Transfer is complete when there is a low to high transition on SDIN while SCLK is high. After a complete sequence the WM8985 returns to the idle state and waits for another start condition. If a start or stop condition is detected out of sequence at any point during data transfer (i.e. SDIN changes while SCLK is high), the control interface returns to the idle condition.

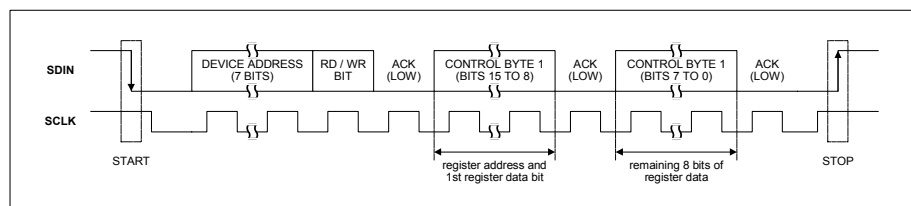


Figure 39 2-Wire Serial Control Interface

In 2-wire mode the WM8985 has a fixed device address, 0011010.

## RESETTING THE CHIP

The WM8985 can be reset by performing a write of any value to the software reset register (address 0h). This will cause all register values to be reset to their default values. In addition to this there is a Power-On Reset (POR) circuit which ensures that the registers are initially set to default when the device is powered up.

## POWER SUPPLIES

The WM8985 requires four separate power supplies:

**AVDD1 and AGND1:** Analogue supply, powers all internal analogue functions and output drivers LOUT1, ROUT1, OUT3 and OUT4. AVDD1 must be between 2.5V and 3.6V and has the most significant impact on overall power consumption (except for power consumed in the headphones). Higher AVDD1 will improve audio quality.

**AVDD2 and AGND2:** Output driver supplies, power LOUT2 and ROUT2. AVDD2 must be between 2.5V and 3.6V. AVDD2 can be tied to AVDD1, but it requires separate layout and decoupling capacitors to curb harmonic distortion.

**DCVDD:** Digital core supply, powers all digital functions except the audio and control interface pads. DCVDD must be between 1.71V and 3.6V, and has no effect on audio quality. The return path for DCVDD is DGND, which is shared with DBVDD.

**DBVDD** must be between 1.71V and 3.6V. DBVDD return path is through DGND.

It is possible to use the same supply voltage for all four supplies. However, digital and analogue supplies should be routed and decoupled separately on the PCB to keep digital switching noise out of the analogue signal paths.

## POWER MANAGEMENT

### SAVING POWER BY REDUCING OVERSAMPLING RATE

The default mode of operation of the ADC and DAC digital filters is in 64x oversampling mode. Under the control of ADCOSR128 and DACOSR128 the oversampling rate may be doubled. 64x oversampling results in a slight decrease in noise performance compared to 128x but lowers the power consumption of the device.

REGISTER ADDRESS	BIT	LABEL	DEFAULT	DESCRIPTION
R10 (0Ah) DAC control	3	DACOSR128	0	DAC oversample rate select 0 = 64x (lowest power) 1 = 128x (best SNR)
R14 (0Eh) ADC control	3	ADCOSR128	0	ADC oversample rate select 0 = 64x (lowest power) 1 = 128x (best SNR)

**Table 48 ADC and DAC Oversampling Rate Selection**

### LOW POWER MODE

If only DAC or ADC functionality is required, the WM8985 can be put into a low power mode. In this mode, the DSP core runs at half of the normal rate, reducing digital power consumption of the core by half. For DAC low power only, 3D enhancement with 2-Band equaliser functionality is permitted, where only Band 1 (low shelf) and Band 5 (high shelf) can be used. For ADC low power, the equaliser and 3D cannot be used.

REGISTER ADDRESS	BIT	LABEL	DEFAULT	DESCRIPTION
R7 (07h) Additional Ctrl	8	M128ENB	0	0 = low power mode enabled 1 = low power mode disabled

**Table 49 DSP Core Low Power Mode Control**

There are 3 modes of low power operation, as detailed below. The device will not enter low power unless in one of these register configurations, regardless of M128ENB.

For pop-free operation of the device it is recommended to change the M128ENB low power functionality only when both the DACs and ADCs are disabled, i.e. when DACENL=0, DACENR=0, ADCENL=0 and ADCENR=0.

FUNCTION	REGISTER BITS	SETTING	DESCRIPTION
ADC low power	M128ENB	0	Either or both of ADCENL and ADCENR must be set (mono or stereo mode)
	ADCENL	1	
	ADCENR	1	
	DACENL	0	
	DACENR	0	
	EQ3DMODE	1 (DAC path)	
DAC low power	M128ENB	0	Either or both of DACENL and DACENR must be set (mono or stereo mode)
	ADCENL	0	
	ADCENR	0	
	DACENL	1	
	DACENR	1	

**Table 50 DSP Core Low Power Modes for ADC Only and DAC Only Modes**

**VMID**

The analogue circuitry will not operate unless VMID is enabled. The impedance of the VMID resistor string, together with the decoupling capacitor on the VMID pin will determine the start-up time of the VMID circuit.

REGISTER ADDRESS	BIT	LABEL	DEFAULT	DESCRIPTION
R1 (01h) Power management 1	1:0	VMIDSEL	00	Reference string impedance to VMID pin (Determines startup time): 00 = off (250kΩ VMID to AGND1) 01 = 100kΩ 10 = 500kΩ 11 = 10kΩ (for fast startup)

**Table 51 VMID Impedance Control**

**BIASEN**

The analogue amplifiers will not operate unless BIASEN is enabled.

REGISTER ADDRESS	BIT	LABEL	DEFAULT	DESCRIPTION
R1 (01h) Power management 1	3	BIASEN	0	Analogue amplifier bias control 0 = disabled 1 = enabled

**Table 52 Analogue Bias Control**

**REGISTER MAP**

ADDR B[15:9]	REGISTER NAME	B8	B7	B6	B5	B4	B3	B2	B1	B0	DEF'T VAL (HEX)	
DEC HEX												
0 00	Software Reset	Software reset										
1 01	Power manage't 1	0	OUT4MIX EN	OUT3MIX EN	PLLEN	MICBEN	BIASEN	BUFIOEN	VMIDSEL[1:0]		000	
2 02	Power manage't 2	ROUT1EN	LOUT1EN	SLEEP	BOOST ENR	BOOST ENL	INPGA ENR	INPPGA ENL	ADCENR	ADCENL	000	
3 03	Power manage't 3	OUT4EN	OUT3EN	ROUT2EN	LOUT2EN	0	RMIXEN	LMIXEN	DACENR	DACENL	000	
4 04	Audio Interface	BCP	LRP	WL		FMT		DLRSWAP	ALRSWAP	MONO	050	
5 05	Companding ctrl	0			WL8	DAC_COMP[1:0]		ADC_COMP[1:0]		LOOP BACK	000	
6 06	Clock Gen ctrl	CLKSEL	MCLKDIV[2:0]			BCLKDIV[2:0]			0	MS	140	
7 07	Additional ctrl	M128ENB	DCLKDIV[3:0]			SR[2:0]			SLOWCLK EN		080	
8 08	GPIO Stuff	GPIO1GP	GPIO1GPU	GPIO1GPD	OPCLKDIV		GPIO1POL	GPIO1SEL[2:0]			000	
9 09	Jack detect control	0	0	JD_EN	JD_SEL		0	0	0	0	000	
10 0A	DAC Control	0	0	SOFT MUTE	0	0	DACOSR 128	AMUTE	DACRPOL	DACLPOL	000	
11 0B	Left DAC digital Vol	DACVU	DACLVOL[7:0]								OFF	
12 0C	Right DAC dig'l Vol	DACVU	DACRVOL[7:0]								OFF	
13 0D	Jack Detect Control	0	JD_EN1[3:0]			JD_EN0[3:0]					000	
14 0E	ADC Control	HPFEN	HPFAPP	HPFCUT[2:0]			ADCOSR 128	0	ADCRPOL	ADCLPOL	100	
15 0F	Left ADC Digital Vol	ADCVU	ADCLVOL[7:0]								OFF	
16 10	Right ADC Digital Vol	ADCVU	ADCRVOL[7:0]								OFF	
18 12	EQ1 – low shelf	EQ3DMODE	0	EQ1C[1:0]		EQ1G[4:0]					12C	
19 13	EQ2 – peak 1	EQ2BW	0	EQ2C[1:0]		EQ2G[4:0]					02C	
20 14	EQ3 – peak 2	EQ3BW	0	EQ3C[1:0]		EQ3G[4:0]					02C	
21 15	EQ4 – peak 3	EQ4BW	0	EQ4C[1:0]		EQ4G[4:0]					02C	
22 16	EQ5 – high shelf	0	0	EQ5C[1:0]		EQ5G[4:0]					02C	
23 17	Class D Control	CLASSDEN	0	0	0	0	10		0	0	008	
24 18	DAC Limiter 1	LIMEN	LIMDCY[3:0]			LIMATK[3:0]					032	
25 19	DAC Limiter 2	0	0	LIMLVL[2:0]			LIMBOOST[3:0]					000
27 1B	Notch Filter 1	NFU	NFEN	NFA0[13:7]							000	
28 1C	Notch Filter 2	NFU	0	NFA0[6:0]							000	
29 1D	Notch Filter 3	NFU	0	NFA1[13:7]							000	
30 1E	Notch Filter 4	NFU	0	NFA1[6:0]							000	
32 20	ALC control 1	ALCSEL[1:0]		0	ALCMAX[2:0]			ALCMIN[2:0]			038	
33 21	ALC control 2	0	ALCHLD[3:0]			ALCLVL[3:0]					00B	
34 22	ALC control 3	ALCMODE	ALCDCY[3:0]			ALCATK[3:0]					032	
35 23	Noise Gate	0	0	0	0	0	NGEN	NGTH[2:0]			000	
36 24	PLL N	0	0	0	0	PLLPRE SCALE	PLLN[3:0]				008	
37 25	PLL K 1	0	0	0	PLLK[23:18]						00C	
38 26	PLL K 2	PLLK[17:9]									093	
39 27	PLL K 3	PLLK[8:0]									0E9	
41 29	3D control	DEPTH3D[3:0]									000	
42 2A	OUT4 to ADC	OUT4_2ADCVOL[2:0]			OUT4_2 LNR	0	0	POBCTRL	0	0		
43 2B	Beep control	BYPL2 RMIX	BYPR2 LMIX	0	0	0	0	0	0	0	000	

ADDR B[15:9]		REGISTER NAME	B8	B7	B6	B5	B4	B3	B2	B1	B0	DEF'T VAL (HEX)
DEC	HEX											
44	2C	Input ctrl	MBVSEL	0	R2_2 INPPGA	RIN2 INPPGA	RIP2 INPPGA	0	L2_2 INPPGA	LIN2 INPPGA	LIP2 INPPGA	003
45	2D	Left INP PGA gain ctrl	INPGAVU	INPPGA ZCL	INPPGA MUTEL	INPPGAVOLL[5:0]					010	
46	2E	Right INP PGA gain ctrl	INPGAVU	INPPGA ZCR	INPPGA MUTER	INPPGAVOLR[5:0]					010	
47	2F	Left ADC Boost ctrl	PGA BOOSTL	0	L2_2BOOSTVOL[2:0]		0	AUXL2BOOSTVOL[2:0]			100	
48	30	Right ADC Boost ctrl	PGA BOOSTR	0	R2_2BOOSTVOL[2:0]		0	AUXR2BOOSTVOL[2:0]			100	
49	31	Output ctrl	0	0	DACL2 RMIX	DACR2 LMIX	0	0	TSOP CTRL	TSDEN	VROI	002
50	32	Left mixer ctrl	AUXLMIXVOL[2:0]			AUXL2 LMIX	BYPLMIXVOL[2:0]			BYPL2 LMIX	DACL2 LMIX	001
51	33	Right mixer ctrl	AUXRMIXVOL[2:0]			AUXR2 RMIX	BYPRMIXVOL[2:0]			BYPR2 RMIX	DACR2 RMIX	001
52	34	LOUT1 (HP) volume ctrl	OUT1VU	LOUT1ZC	LOUT1 MUTE	LOUT1VOL[5:0]					039	
53	35	ROUT1 (HP) volume ctrl	OUT1VU	ROUT1ZC	ROUT1 MUTE	ROUT1VOL[5:0]					039	
54	36	LOUT2 (SPK) volume ctrl	OUT2VU	LOUT2ZC	LOUT2 MUTE	LOUT2VOL[5:0]					039	
55	37	ROUT2 (SPK) volume ctrl	OUT2VU	ROUT2ZC	ROUT2 MUTE	ROUT2VOL[5:0]					039	
56	38	OUT3 mixer ctrl	0	0	OUT3 MUTE	0	0	OUT4_ 2OUT3	BYPL2 OUT3	LMIX2 OUT3	LDAC2 OUT3	001
57	39	OUT4 (MONO) mixer ctrl	0	OUT 3_2OUT4	OUT4 MUTE	OUT4 ATTN	LMIX2 OUT4	LDAC2 OUT4	BYPR2 OUT4	RMIX2 OUT4	RDAC2 OUT4	001
61	3D	Bias Control	BIASCUT	0	0	0	00		00		0	000

Table 53 WM8985 Register Map

**REGISTER BITS BY ADDRESS****Notes:**

1. Default values of N/A indicate non-latched data bits (e.g. software reset or volume update bits).
2. Register bits marked as "Reserved" should not be changed from the default.

REGISTER ADDRESS	BIT	LABEL	DEFAULT	DESCRIPTION	REFER TO
0 (00h)	[8:0]	RESET	N/A	Software reset	Resetting the Chip
1 (01h)	8		0	Reserved. Initialise to 0	
	7	OUT4MIXEN	0	OUT4 mixer enable 0=disabled 1=enabled	Power Management
	6	OUT3MIXEN	0	OUT3 mixer enable 0=disabled 1=enabled	Power Management
	5	PLEN	0	PLL enable 0=PLL off 1=PLL on	Master Clock and Phase Locked Loop (PLL)
	4	MICBEN	0	Microphone Bias Enable 0 = OFF (high impedance output) 1 = ON	Input Signal Path
	3	BIASEN	0	Analogue amplifier bias control 0=disabled 1=enabled	Power Management
	2	BUFIOEN	0	Unused input/output tie off buffer enable 0=disabled 1=enabled	Power Management
	1:0	VMIDSEL	00	Reference string impedance to VMID pin 00=off (open circuit) 01=75kΩ 10=300kΩ 11=5kΩ	Power Management
2 (02h)	8	ROUT1EN	0	ROUT1 output enable 0=disabled 1=enabled	Power Management
	7	LOUT1EN	0	LOUT1 output enable 0=disabled 1=enabled	Power Management
	6	SLEEP	0	0 = normal device operation 1 = residual current reduced in device standby mode	Power Management
	5	BOOSTENR	0	Right channel Input BOOST enable 0 = Boost stage OFF 1 = Boost stage ON	Power Management
	4	BOOSTENL	0	Left channel Input BOOST enable 0 = Boost stage OFF 1 = Boost stage ON	Power Management
	3	INPPGAENR	0	Right channel input PGA enable 0 = disabled 1 = enabled	Power Management
	2	INPPGAENL	0	Left channel input PGA enable 0 = disabled 1 = enabled	Power Management

REGISTER ADDRESS	BIT	LABEL	DEFAULT	DESCRIPTION	REFER TO
	1	ADCENR	0	Enable ADC right channel: 0 = ADC disabled 1 = ADC enabled	Analogue to Digital Converter (ADC)
	0	ADCENL	0	Enable ADC left channel: 0 = ADC disabled 1 = ADC enabled	Analogue to Digital Converter (ADC)
3 (03h)	8	OUT4EN	0	OUT4 enable 0 = disabled 1 = enabled	Power Management
	7	OUT3EN	0	OUT3 enable 0 = disabled 1 = enabled	Power Management
	6	ROUT2EN	0	ROUT2 enable 0 = disabled 1 = enabled	Power Management
	5	LOUT2EN	0	LOUT2 enable 0 = disabled 1 = enabled	Power Management
	4		0	Reserved. Initialise to 0	
	3	RMIXEN	0	Right output channel mixer enable: 0 = disabled 1 = enabled	Analogue Outputs
	2	LMIXEN	0	Left output channel mixer enable: 0 = disabled 1 = enabled	Analogue Outputs
	1	DACENR	0	Right channel DAC enable 0 = DAC disabled 1 = DAC enabled	Analogue Outputs
	0	DACENL	0	Left channel DAC enable 0 = DAC disabled 1 = DAC enabled	Analogue Outputs
4 (04h)	8	BCP	0	BCLK polarity 0=normal 1=inverted	Digital Audio Interfaces
	7	LRP	0	LRC clock polarity 0=normal 1=inverted	Digital Audio Interfaces
	6:5	WL	10	Word length 00=16 bits 01=20 bits 10=24 bits 11=32 bits	Digital Audio Interfaces
	4:3	FMT	10	Audio interface Data Format Select: 00=Right Justified 01=Left Justified 10=I <sup>2</sup> S format 11= DSP/PCM mode	Digital Audio Interfaces

REGISTER ADDRESS	BIT	LABEL	DEFAULT	DESCRIPTION	REFER TO
	2	DLRSWAP	0	Controls whether DAC data appears in 'right' or 'left' phases of LRC clock: 0=DAC data appear in 'left' phase of LRC 1=DAC data appears in 'right' phase of LRC	Digital Audio Interfaces
	1	ALRSWAP	0	Controls whether ADC data appears in 'right' or 'left' phases of LRC clock: 0=ADC data appear in 'left' phase of LRC 1=ADC data appears in 'right' phase of LRC	Digital Audio Interfaces
	0	MONO	0	Selects between stereo and mono device operation: 0=Stereo device operation 1=Mono device operation. Data appears in 'left' phase of LRC	Digital Audio Interfaces
5 (05h)	8:6		000	Reserved. Initialise to 0	
	5	WL8	0	Companding Control 8-bit mode 0=off 1=device operates in 8-bit mode	Digital Audio Interfaces
	4:3	DAC_COMP	00	DAC companding 00=off (linear mode) 01=reserved 10= $\mu$ -law 11=A-law	Digital Audio Interfaces
	2:1	ADC_COMP	00	ADC companding 00=off (linear mode) 01=reserved 10= $\mu$ -law 11=A-law	Digital Audio Interfaces
	0	LOOPBACK	0	Digital loopback function 0=No loopback 1=Loopback enabled, ADC data output is fed directly into DAC data input.	Digital Audio Interfaces
6 (06h)	8	CLKSEL	1	Controls the source of the clock for all internal operation: 0=MCLK 1=PLL output	Digital Audio Interfaces
	7:5	MCLKDIV	010	Sets the scaling for either the MCLK or PLL clock output (under control of CLKSEL) 000=divide by 1 001=divide by 1.5 010=divide by 2 011=divide by 3 100=divide by 4 101=divide by 6 110=divide by 8 111=divide by 12	Digital Audio Interfaces

REGISTER ADDRESS	BIT	LABEL	DEFAULT	DESCRIPTION	REFER TO
	4:2	BCLKDIV	000	Configures the BCLK output frequency, for use when the chip is master over BCLK. 000=divide by 1 (BCLK=MCLK) 001=divide by 2 (BCLK=MCLK/2) 010=divide by 4 011=divide by 8 100=divide by 16 101=divide by 32 110=reserved 111=reserved	Digital Audio Interfaces
	1		0	Reserved. Initialise to 0	
	0	MS	0	Sets the chip to be master over LRC and BCLK 0=BCLK and LRC clock are inputs 1=BCLK and LRC clock are outputs generated by the WM8978 (MASTER)	Digital Audio Interfaces
7 (07h)	8	M128ENB	0	0 = low power mode enabled 1 = low power mode disabled	Additional Control
	7:4	DCLKDIV	1000	Controls clock division from SYSCLK to generate suitable class D clock. Recommended class D clock frequency = 1.4MHz. 0000 = divide by 1 0010 = divide by 2 0011 = divide by 3 0100 = divide by 4 0101 = divide by 5.5 0110 = divide by 6 1000 = divide by 8 1001 = divide by 12 1010 = divide by 16	Class A / D Headphone Outputs
	3:1	SR	000	Approximate sample rate (configures the coefficients for the internal digital filters): 000=48kHz 001=32kHz 010=24kHz 011=16kHz 100=12kHz 101=8kHz 110-111=reserved	Audio Sample Rates
	0	SLOWCLKEN	0	Slow clock enable. Used for both the jack insert detect debounce circuit and the zero cross timeout. 0 = slow clock disabled 1 = slow clock enabled	Analogue Outputs
	8 (08h)	8	GPIO1GP	0	GPIO1 Open drain enable 0 = Open drain disabled 1 = Open drain enabled
	7	GPIO1GPU	0	GPIO1 Internal pull-up enable: 0 = Internal pull-up disabled 1 = Internal pull-up enabled	General Purpose Input/Output (GPIO)
	6	GPIO1GPD	0	GPIO1 Internal pull-down enable: 0 = Internal pull-down disabled 1 = Internal pull-down enabled	General Purpose Input/Output (GPIO)

REGISTER ADDRESS	BIT	LABEL	DEFAULT	DESCRIPTION	REFER TO
	5:4	OPCLKDIV	00	PLL Output clock division ratio 00=divide by 1 01=divide by 2 10=divide by 3 11=divide by 4	General Purpose Input/Output (GPIO)
	3	GPIO1POL	0	GPIO1 Polarity invert 0=Non inverted 1=Inverted	General Purpose Input/Output (GPIO)
	2:0	GPIO1SEL [2:0]	000	CSB/GPIO1 pin function select: 000= input (CSB/jack detection: depending on MODE setting) 001= reserved 010=Temp ok 011=Amute active 100=PLL clk o/p 101=PLL lock 110=logic 1 111=logic 0	General Purpose Input/Output (GPIO)
9 (09h)	8:7		00	Reserved. Initialise to 00	
	6	JD_EN	0	Jack Detection Enable 0=disabled 1=enabled	Output Switching (Jack Detect)
	5:4	JD_SEL	00	Pin selected as jack detection input 00 = GPIO1 01 = GPIO2 10 = GPIO3 11 = Reserved	Output Switching (Jack Detect)
	3:0		0	Reserved. Initialise to 0	
10 (0Ah)	8:7		00	Reserved. Initialise to 0	
	6	SOFTMUTE	0	Softmute enable: 0=Disabled 1=Enabled	Output Signal Path
	5:4		00	Reserved. Initialise to 0	
	3	DACOSR128	0	DAC oversample rate select 0 = 64x (lowest power) 1 = 128x (best SNR)	Power Management
	2	AMUTE	0	Automute enable 0 = Amute disabled 1 = Amute enabled	Output Signal Path
	1	DACPOLR	0	Right DAC output polarity: 0 = non-inverted 1 = inverted (180 degrees phase shift)	Output Signal Path
	0	DACPOLL	0	Left DAC output polarity: 0 = non-inverted 1 = inverted (180 degrees phase shift)	Output Signal Path
11 (0Bh)	8	DACVU	N/A	DAC left and DAC right volume do not update until a 1 is written to DACVU (in reg 11 or 12)	Digital to Analogue Converter (DAC)

REGISTER ADDRESS	BIT	LABEL	DEFAULT	DESCRIPTION	REFER TO
	7:0	DACVOLL	11111111	Left DAC Digital Volume Control 0000 0000 = Digital Mute 0000 0001 = -127dB 0000 0010 = -126.5dB ... 0.5dB steps up to 1111 1111 = 0dB	Digital to Analogue Converter (DAC)
12 (0Ch)	8	DACVU	N/A	DAC left and DAC right volume do not update until a 1 is written to DACVU (in reg 11 or 12)	Output Signal Path
	7:0	DACVOLR	11111111	Right DAC Digital Volume Control 0000 0000 = Digital Mute 0000 0001 = -127dB 0000 0010 = -126.5dB ... 0.5dB steps up to 1111 1111 = 0dB	Output Signal Path
13 (0Dh)	8		0	Reserved. Initialise to 0	
	7:4	JD_EN1	0000	Output enabled when selected jack detection input is logic 1 [4]= OUT1_EN_1 [5]= OUT2_EN_1 [6]= OUT3_EN_1 [7]= OUT4_EN_1	Output Switching (Jack Detect)
	3:0	JD_EN0	0000	Output enabled when selected jack detection input is logic 0. [0]= OUT1_EN_0 [1]= OUT2_EN_0 [2]= OUT3_EN_0 [3]= OUT4_EN_0	Output Switching (Jack Detect)
14 (0Eh)	8	HPFEN	1	High Pass Filter Enable 0=disabled 1=enabled	Analogue to Digital Converter (ADC)
	7	HPFAPP	0	Select audio mode or application mode 0=Audio mode (1 <sup>st</sup> order, fc = ~3.7Hz) 1=Application mode (2 <sup>nd</sup> order, fc = HPFCUT)	Analogue to Digital Converter (ADC)
	6:4	HPFCUT	000	Application mode cut-off frequency See Figure 15 for details.	Analogue to Digital Converter (ADC)
	3	ADCOSR 128	0	ADC oversample rate select 0 = 64x (lowest power) 1 = 128x (best SNR)	Power Management
	2		0	Reserved. Initialise to 0	
	1	ADCRPOL	0	ADC right channel polarity adjust: 0=normal 1=inverted	Analogue to Digital Converter (ADC)
	0	ADCLPOL	0	ADC left channel polarity adjust: 0=normal 1=inverted	Analogue to Digital Converter (ADC)
15 (0Fh)	8	ADCVU	N/A	ADC left and ADC right volume do not update until a 1 is written to ADCVU (in reg 16 or 17)	Analogue to Digital Converter (ADC)

REGISTER ADDRESS	BIT	LABEL	DEFAULT	DESCRIPTION	REFER TO
	7:0	ADCVOLL	11111111	Left ADC Digital Volume Control 0000 0000 = Digital Mute 0000 0001 = -127dB 0000 0010 = -126.5dB ... 0.5dB steps up to 1111 1111 = 0dB	Analogue to Digital Converter (ADC)
16 (10h)	8	ADCVU	N/A	ADC left and ADC right volume do not update until a 1 is written to ADCVU (in reg 16 or 17)	Analogue to Digital Converter (ADC)
	7:0	ADCVOLR	11111111	Right ADC Digital Volume Control 0000 0000 = Digital Mute 0000 0001 = -127dB 0000 0010 = -126.5dB ... 0.5dB steps up to 1111 1111 = 0dB	Analogue to Digital Converter (ADC)
18 (12h)	8	EQ3DMODE	1	0 = Equaliser and 3D Enhancement applied to ADC path 1 = Equaliser and 3D Enhancement applied to DAC path	Output Signal Path
	7		0	Reserved. Initialise to 0	
	6:5	EQ1C	01	EQ Band 1 Cut-off Frequency: 00=80Hz 01=105Hz 10=135Hz 11=175Hz	Output Signal Path
	4:0	EQ1G	01100	EQ Band 1 Gain Control. See Table 31 for details.	Output Signal Path
19 (13h)	8	EQ2BW	0	EQ Band 2 Bandwidth Control 0=narrow bandwidth 1=wide bandwidth	Output Signal Path
	7		0	Reserved. Initialise to 0	
	6:5	EQ2C	01	EQ Band 2 Centre Frequency: 00=230Hz 01=300Hz 10=385Hz 11=500Hz	Output Signal Path
	4:0	EQ2G	01100	EQ Band 2 Gain Control. See Table 31 for details.	Output Signal Path
20 (14h)	8	EQ3BW	0	EQ Band 3 Bandwidth Control 0=narrow bandwidth 1=wide bandwidth	Output Signal Path
	7		0	Reserved. Initialise to 0	
	6:5	EQ3C	01	EQ Band 3 Centre Frequency: 00=650Hz 01=850Hz 10=1.1kHz 11=1.4kHz	Output Signal Path
	4:0	EQ3G	01100	EQ Band 3 Gain Control. See Table 31 for details.	Output Signal Path
21 (15h)	8	EQ4BW	0	EQ Band 4 Bandwidth Control 0=narrow bandwidth 1=wide bandwidth	Output Signal Path
	7		0	Reserved. Initialise to 0	

REGISTER ADDRESS	BIT	LABEL	DEFAULT	DESCRIPTION	REFER TO
	6:5	EQ4C	01	EQ Band 4 Centre Frequency: 00=1.8kHz 01=2.4kHz 10=3.2kHz 11=4.1kHz	Output Signal Path
	4:0	EQ4G	01100	EQ Band 4 Gain Control. See Table 31 for details.	Output Signal Path
22 (16h)	8:7		0	Reserved. Initialise to 0	Output Signal Path
	6:5	EQ5C	01	EQ Band 5 Cut-off Frequency: 00=5.3kHz 01=6.9kHz 10=9kHz 11=11.7kHz	Output Signal Path
	4:0	EQ5G	01100	EQ Band 5 Gain Control. See Table 31 for details.	Output Signal Path
23 (17h)	8	CLASSDEN	0	Enable signal for class D mode on LOUT2 and ROUT2 0 = Class AB mode 1 = Class D mode	Class D Control
	7:0		000 0000	Reserved. Initialise to 0	
24 (18h)	8	LIMEN	0	Enable the DAC digital limiter: 0=disabled 1=enabled	Output Signal Path
	7:4	LIMDCY	0011	DAC Limiter Decay time (per 6dB gain change) for 44.1kHz sampling. Note that these will scale with sample rate: 0000=750us 0001=1.5ms 0010=3ms 0011=6ms 0100=12ms 0101=24ms 0110=48ms 0111=96ms 1000=192ms 1001=384ms 1010=768ms	Output Signal Path
	3:0	LIMATK	0010	DAC Limiter Attack time (per 6dB gain change) for 44.1kHz sampling. Note that these will scale with sample rate. 0000=94us 0001=188s 0010=375us 0011=750us 0100=1.5ms 0101=3ms 0110=6ms 0111=12ms 1000=24ms 1001=48ms 1010=96ms 1011 to 1111=192ms	Output Signal Path

REGISTER ADDRESS	BIT	LABEL	DEFAULT	DESCRIPTION	REFER TO
25 (19h)	8:7		00	Reserved. Initialise to 0	
	6:4	LIMLVL	000	Programmable signal threshold level (determines level at which the DAC limiter starts to operate) 000=-1dB 001=-2dB 010=-3dB 011=-4dB 100=-5dB 101 to 111=-6dB	Output Signal Path
	3:0	LIMBOOST	0000	DAC Limiter volume boost (can be used as a stand alone volume boost when LIMEN=0): 0000=0dB 0001=+1dB 0010=+2dB ... (1dB steps) 1011=+11dB 1100=+12dB 1101 to 1111=reserved	Output Signal Path
27 (1Bh)	8	NFU	0	Notch filter update. The notch filter values used internally only update when one of the NFU bits is set high.	Analogue to Digital Converter (ADC)
	7	NFEN	0	Notch filter enable: 0=Disabled 1=Enabled	Analogue to Digital Converter (ADC)
	6:0	NFA0[13:7]	0000000	Notch Filter a0 coefficient, bits [13:7]	Analogue to Digital Converter (ADC)
28 (1Ch)	8	NFU	0	Notch filter update. The notch filter values used internally only update when one of the NFU bits is set high.	Analogue to Digital Converter (ADC)
	7		0	Reserved. Initialise to 0	
	6:0	NFA0[6:0]	0000000	Notch Filter a0 coefficient, bits [6:0]	Analogue to Digital Converter (ADC)
29 (1Dh)	8	NFU	0	Notch filter update. The notch filter values used internally only update when one of the NFU bits is set high.	Analogue to Digital Converter (ADC)
	7		0	Reserved. Initialise to 0	
	6:0	NFA1[13:7]	0000000	Notch Filter a1 coefficient, bits [13:7]	Analogue to Digital Converter (ADC)
30 (1Eh)	8	NFU	0	Notch filter update. The notch filter values used internally only update when one of the NFU bits is set high.	Analogue to Digital Converter (ADC)
	7		0	Reserved. Initialise to 0	
	6:0	NFA1[6:0]	0000000	Notch Filter a1 coefficient, bits [6:0]	Analogue to Digital Converter (ADC)

REGISTER ADDRESS	BIT	LABEL	DEFAULT	DESCRIPTION	REFER TO																							
32 (20h)	8:7	ALCSEL	00	ALC function select: 00=ALC off 01=ALC right only 10=ALC left only 11=ALC both on	Input Limiter/ Automatic Level Control (ALC)																							
	6		0	Reserved. Initialise to 0																								
	5:3	ALCMAXGAIN	111	Set Maximum Gain of PGA 111=+35.25dB 110=+29.25dB 101=+23.25dB 100=+17.25dB 011=+11.25dB 010=+5.25dB 001=-0.75dB 000=-6.75dB	Input Limiter/ Automatic Level Control (ALC)																							
	2:0	ALCMINGAIN	000	Set minimum gain of PGA 000=-12dB 001=-6dB 010=0dB 011=+6dB 100=+12dB 101=+18dB 110=+24dB 111=+30dB	Input Limiter/ Automatic Level Control (ALC)																							
33 (21h)	7:4	ALCHLD	0000	ALC hold time before gain is increased. 0000 = 0ms 0001 = 2.67ms 0010 = 5.33ms ... (time doubles with every step) 1111 = 43.691s	Input Limiter/ Automatic Level Control (ALC)																							
	3:0	ALCLVL	1011	ALC target – sets signal level at ADC input 1111 : -1.5dBFS 1110 : -1.5dBFS 1101 : -3dBFS 1100 : -4.5dBFS ..... (-1.5dB steps) 0001 : -21dBFS 0000 : -22.5dBFS	Input Limiter/ Automatic Level Control (ALC)																							
34 (22h)	8	ALCMODE	0	Determines the ALC mode of operation: 0=ALC mode 1=Limiter mode	Input Limiter/ Automatic Level Control (ALC)																							
	7:4	ALCDCY [3:0]	0011	Decay (gain ramp-up) time (ALCMODE ==0) <table border="1" data-bbox="762 1778 1238 1935"> <thead> <tr> <th></th> <th>Per step</th> <th>Per 6dB</th> <th>90% of range</th> </tr> </thead> <tbody> <tr> <td>0000</td> <td>410us</td> <td>3.3ms</td> <td>24ms</td> </tr> <tr> <td>0001</td> <td>820us</td> <td>6.6ms</td> <td>48ms</td> </tr> <tr> <td>0010</td> <td>1.64ms</td> <td>13.1ms</td> <td>192ms</td> </tr> <tr> <td colspan="4">... (time doubles with every step)</td> </tr> <tr> <td>1010 or higher</td> <td>420ms</td> <td>3.36s</td> <td>24.576s</td> </tr> </tbody> </table> 0011 Decay (gain ramp-up) time (ALCMODE ==1)		Per step	Per 6dB	90% of range	0000	410us	3.3ms	24ms	0001	820us	6.6ms	48ms	0010	1.64ms	13.1ms	192ms	... (time doubles with every step)				1010 or higher	420ms	3.36s	24.576s
	Per step	Per 6dB	90% of range																									
0000	410us	3.3ms	24ms																									
0001	820us	6.6ms	48ms																									
0010	1.64ms	13.1ms	192ms																									
... (time doubles with every step)																												
1010 or higher	420ms	3.36s	24.576s																									

REGISTER ADDRESS	BIT	LABEL	DEFAULT	DESCRIPTION	REFER TO	
					Per step   Per 6dB   90% of range	
				0000	90.8us   726.4us   5.26ms	
				0001	181.6us   1.453ms   10.53ms	
				0010	363.2us   2.905ms   21.06ms	
				... (time doubles with every step)		
	1010	93ms   744ms   5.39s				
	3:0	ALCATK	0010	ALC attack (gain ramp-down) time (ALCMODE == 0)		Input Limiter/ Automatic Level Control (ALC)
					Per step   Per 6dB   90% of range	
	0000	104us   832us   6ms				
	0001	208us   1.664ms   12ms				
	0010	416us   3.328ms   24.1ms				
	... (time doubles with every step)					
	1010 or higher	106ms   852ms   6.18s				
			0010	ALC attack (gain ramp-down) time (ALCMODE == 1)		
					Per step   Per 6dB   90% of range	
	0000	22.7us   182.4us   1.31ms				
0001	45.4us   363.2us   2.62ms					
0010	90.8us   726.4us   5.26ms					
... (time doubles with every step)						
1010	23.2ms   186ms   1.348s					
35 (23h)	8:4		00000	Reserved. Initialise to 0		
	3	NGEN	0	ALC Noise gate function enable 1 = enable 0 = disable		
	2:0	NGTH	000	ALC Noise gate threshold: 000=-39dB 001=-45dB 010=-51dB ... (6dB steps) 111=-81dB		
36 (24h)	8:5		0000	Reserved. Initialise to 0		
	4	PLLPRESCALE	0	0 = MCLK input not divided (default) 1 = Divide MCLK by 2 before input to PLL		
	3:0	PLLN[3:0]	1000	Integer (N) part of PLL input/output frequency ratio. Use values greater than 5 and less than 13.		
37 (25h)	8:6		000	Reserved. Initialise to 0		
	5:0	PLLK[23:18]	01100	Fractional (K) part of PLL1 input/output frequency ratio (treat as one 24-digit binary number).		
38 (26h)	8:0	PLLK[17:9]	010010011	Fractional (K) part of PLL1 input/output frequency ratio (treat as one 24-digit binary number).		

REGISTER ADDRESS	BIT	LABEL	DEFAULT	DESCRIPTION	REFER TO
39 (27h)	8:0	PLLK[8:0]	011101001	Fractional (K) part of PLL1 input/output frequency ratio (treat as one 24-digit binary number).	Master Clock and Phase Locked Loop (PLL)
41 (29h)	8:4		00000	Reserved. Initialise to 0	
	3:0	DEPTH3D	0000	Stereo depth 0000: 0% (minimum 3D effect) 0001: 6.67% .... 1110: 93.3% 1111: 100% (maximum 3D effect)	3D Stereo Enhancement
42 (2Ah)	8:6	OUT4_2ADCVOL	000	Controls the OUT4 to ADC input boost stage: 000 = Path disabled (disconnected) 001 = -12dB gain 010 = -9dB gain 011 = -6dB gain 100 = -3dB gain 101 = +0dB gain 110 = +3dB gain 111 = +6dB gain	Analogue Outputs
	5	OUT4_2LNR	0	OUT4 to L or R ADC input 0 = Right ADC input 1 = Left ADC input	Analogue Outputs
	4:0		0 0000	Reserved. Initialise to 0	
43 (2Bh)	8	BYPL2RMIX	0	Left bypass path (from the Left channel input PGA stage) to right output mixer 0 = not selected 1 = selected	Analogue Outputs
	7	BYPR2LMIX	0	Right bypass path (from the right channel input PGA stage) to Left output mixer 0 = not selected 1 = selected	Analogue Outputs
	6		0	Reserved. Initialise to 0	
	5	MUTERPGA2INV	0	Mute input to INVROUT2 mixer	Analogue Outputs
	4	INVROUT2	0	Mute input to INVROUT2 mixer	Analogue Outputs
	3:1	BEEPVOL	000	AUXR input to ROUT2 inverter gain 000 = -15dB ... 111 = +6dB	Analogue Outputs
	0	BEEPEN	0	0 = mute AUXR beep input 1 = enable AUXR beep input	Analogue Outputs
44 (2Ch)	8	MBVSEL	0	Microphone Bias Voltage Control 0 = $0.9 * AVDD$ 1 = $0.65 * AVDD$	Input Signal Path
	7		0	Reserved. Initialise to 0	
	6	R2_2INPPGA	0	Connect R2 pin to right channel input PGA positive terminal. 0=R2 not connected to input PGA 1=R2 connected to input PGA amplifier positive terminal (constant input impedance).	Input Signal Path

REGISTER ADDRESS	BIT	LABEL	DEFAULT	DESCRIPTION	REFER TO
	5	RIN2INPPGA	1	Connect RIN pin to right channel input PGA negative terminal. 0=RIN not connected to input PGA 1=RIN connected to right channel input PGA amplifier negative terminal.	Input Signal Path
	4	RIP2INPPGA	1	Connect RIP pin to right channel input PGA amplifier positive terminal. 0 = RIP not connected to input PGA 1 = right channel input PGA amplifier positive terminal connected to RIP (constant input impedance)	Input Signal Path
	3		0	Reserved. Initialise to 0	
	2	L2_2INPPGA	0	Connect L2 pin to left channel input PGA positive terminal. 0=L2 not connected to input PGA 1=L2 connected to input PGA amplifier positive terminal (constant input impedance).	Input Signal Path
	1	LIN2INPPGA	1	Connect LIN pin to left channel input PGA negative terminal. 0=LIN not connected to input PGA 1=LIN connected to input PGA amplifier negative terminal.	Input Signal Path
	0	LIP2INPPGA	1	Connect LIP pin to left channel input PGA amplifier positive terminal. 0 = LIP not connected to input PGA 1 = input PGA amplifier positive terminal connected to LIP (constant input impedance)	Input Signal Path
	45 (2Dh)	8	INPPGAU	N/A	INPPGAVOLL and INPPGAVOLR volume do not update until a 1 is written to INPPGAUPDATE (in reg 45 or 46)
45 (2Dh)	7	INPPGAZCL	0	Left channel input PGA zero cross enable: 0=Update gain when gain register changes 1=Update gain on 1 <sup>st</sup> zero cross after gain register write.	Input Signal Path
	6	INPPGAMUTEL	0	Mute control for left channel input PGA: 0=Input PGA not muted, normal operation 1=Input PGA muted (and disconnected from the following input BOOST stage).	Input Signal Path
	5:0	INPPGAVOLL	010000	Left channel input PGA volume 000000 = -12dB 000001 = -11.25db . 010000 = 0dB . 111111 = 35.25dB	Input Signal Path
46 (2Eh)	8	INPPGAU	N/A	INPPGAVOLL and INPPGAVOLR volume do not update until a 1 is written to INPPGAUPDATE (in reg 45 or 46)	Input Signal Path
	7	INPPGAZCR	0	Right channel input PGA zero cross enable: 0=Update gain when gain register changes 1=Update gain on 1 <sup>st</sup> zero cross after gain register write.	Input Signal Path
	6	INPPGAMUTER	0	Mute control for right channel input PGA: 0=Input PGA not muted, normal operation 1=Input PGA muted (and disconnected from the following input BOOST stage).	Input Signal Path

REGISTER ADDRESS	BIT	LABEL	DEFAULT	DESCRIPTION	REFER TO
	5:0	INPPGAVOLR	010000	Right channel input PGA volume 000000 = -12dB 000001 = -11.25db . 010000 = 0dB . 111111 = +35.25dB	Input Signal Path
47 (2Fh)	8	PGABOOSTL	1	Boost enable for left channel input PGA: 0 = PGA output has +0dB gain through input BOOST stage. 1 = PGA output has +20dB gain through input BOOST stage.	Input Signal Path
	7		0	Reserved. Initialise to 0	
	6:4	L2_2BOOSTVOL	000	Controls the L2 pin to the left channel input boost stage: 000=Path disabled (disconnected) 001=-12dB gain through boost stage 010=-9dB gain through boost stage ... 111=+6dB gain through boost stage	Input Signal Path
	3		0	Reserved. Initialise to 0	
	2:0	AUXL2BOOSTVOL	000	Controls the auxilliary amplifier to the left channel input boost stage: 000=Path disabled (disconnected) 001=-12dB gain through boost stage 010=-9dB gain through boost stage ... 111=+6dB gain through boost stage	Input Signal Path
48 (30h)	8	PGABOOSTR	1	Boost enable for right channel input PGA: 0 = PGA output has +0dB gain through input BOOST stage. 1 = PGA output has +20dB gain through input BOOST stage.	Input Signal Path
	7		0	Reserved. Initialise to 0	
	6:4	R2_2BOOSTVOL	000	Controls the R2 pin to the right channel input boost stage: 000=Path disabled (disconnected) 001=-12dB gain through boost stage 010=-9dB gain through boost stage ... 111=+6dB gain through boost stage	Input Signal Path
	3		0	Reserved. Initialise to 0	
	2:0	AUXR2BOOSTVOL	000	Controls the auxilliary amplifier to the right channel input boost stage: 000=Path disabled (disconnected) 001=-12dB gain through boost stage 010=-9dB gain through boost stage ... 111=+6dB gain through boost stage	Input Signal Path
49 (31h)	8:7		00	Reserved. Initialise to 0	
	6	DACLR2MIX	0	Left DAC output to right output mixer 0 = not selected 1 = selected	Analogue Outputs

REGISTER ADDRESS	BIT	LABEL	DEFAULT	DESCRIPTION	REFER TO
	5	DACR2LMIX	0	Right DAC output to left output mixer 0 = not selected 1 = selected	Analogue Outputs
	4:3		00	Reserved. Initialise to 0	
	2	TSOPCTRL	0	Thermal Shutdown Output enable 0 = Disabled 1 = Enabled, i.e. all outputs will be disabled if TI set and the device junction temperature is more than 125°C.	Analogue Outputs
	1	TSDEN	1	Thermal Shutdown Enable 0 : thermal shutdown disabled 1 : thermal shutdown enabled	Analogue Outputs
	0	VROI	0	VREF (AVDD/2 or 1.5xAVDD/2) to analogue output resistance 0: approx 1kΩ 1: approx 30 kΩ	Analogue Outputs
50 (32h)	8:6	AUXLMIXVOL	000	Aux left channel input to left mixer volume control: 000 = -15dB 001 = -12dB ... 101 = 0dB 110 = +3dB 111 = +6dB	Analogue Outputs
	5	AUXL2LMIX	0	Left Auxilliary input to left channel output mixer: 0 = not selected 1 = selected	Analogue Outputs
	4:2	BYPLMIXVOL	000	Left bypass volume control to output channel mixer: 000 = -15dB 001 = -12dB ... 101 = 0dB 110 = +3dB 111 = +6dB	Analogue Outputs
	1	BYPL2LMIX	0	Left bypass path (from the left channel input boost output) to left output mixer 0 = not selected 1 = selected	Analogue Outputs
	0	DACL2LMIX	1	Left DAC output to left output mixer 0 = not selected 1 = selected	Analogue Outputs
51 (33h)	8:6	AUXRMIXVOL	000	Aux right channel input to right mixer volume control: 000 = -15dB 001 = -12dB ... 101 = 0dB 110 = +3dB 111 = +6dB	Analogue Outputs
	5	AUXR2RMIX	0	Right Auxilliary input to right channel output mixer: 0 = not selected 1 = selected	Analogue Outputs

REGISTER ADDRESS	BIT	LABEL	DEFAULT	DESCRIPTION	REFER TO
	4:2	BYPRMIXVOL	000	Right bypass volume control to output channel mixer: 000 = -15dB 001 = -12dB ... 101 = 0dB 110 = +3dB 111 = +6dB	Analogue Outputs
	1	BYPR2RMIX	0	Right bypass path (from the right channel input boost output) to right output mixer 0 = not selected 1 = selected	Analogue Outputs
	0	DACR2RMIX	1	Right DAC output to right output mixer 0 = not selected 1 = selected	Analogue Outputs
52 (34h)	8	OUT1VU	N/A	LOUT1 and ROUT1 volumes do not update until a 1 is written to OUT1VU (in reg 52 or 53)	Analogue Outputs
	7	LOUT1ZC	0	Headphone volume zero cross enable: 1 = Change gain on zero cross only 0 = Change gain immediately	Analogue Outputs
	6	LOUT1MUTE	0	Left headphone output mute: 0 = Normal operation 1 = Mute	Analogue Outputs
	5:0	LOUT1VOL	111001	Left headphone output volume: 000000 = -57dB ... 111001 = 0dB ... 111111 = +6dB	Analogue Outputs
53 (35h)	8	OUT1VU	N/A	LOUT1 and ROUT1 volumes do not update until a 1 is written to OUT1VU (in reg 52 or 53)	Analogue Outputs
	7	ROUT1ZC	0	Headphone volume zero cross enable: 1 = Change gain on zero cross only 0 = Change gain immediately	Analogue Outputs
	6	ROUT1MUTE	0	Right headphone output mute: 0 = Normal operation 1 = Mute	Analogue Outputs
	5:0	ROUT1VOL	111001	Right headphone output volume: 000000 = -57dB ... 111001 = 0dB ... 111111 = +6dB	Analogue Outputs
54 (36h)	8	OUT2VU	N/A	LOUT2 and ROUT2 volumes do not update until a 1 is written to OUT2VU (in reg 54 or 55)	Analogue Outputs
	7	LOUT2ZC	0	Speaker volume zero cross enable: 1 = Change gain on zero cross only 0 = Change gain immediately	Analogue Outputs
	6	LOUT2MUTE	0	Left speaker output mute: 0 = Normal operation 1 = Mute	Analogue Outputs

REGISTER ADDRESS	BIT	LABEL	DEFAULT	DESCRIPTION	REFER TO
	5:0	LOUT2VOL	111001	Left speaker output volume: 000000 = -57dB ... 111001 = 0dB ... 111111 = +6dB	Analogue Outputs
55 (37h)	8	OUT2VU	N/A	LOUT2 and ROUT2 volumes do not update until a 1 is written to OUT2VU (in reg 54 or 55)	Analogue Outputs
	7	ROUT2ZC	0	Speaker volume zero cross enable: 1 = Change gain on zero cross only 0 = Change gain immediately	Analogue Outputs
	6	ROUT2MUTE	0	Right speaker output mute: 0 = Normal operation 1 = Mute	Analogue Outputs
	5:0	ROUT2VOL	111001	Right speaker output volume: 000000 = -57dB ... 111001 = 0dB ... 111111 = +6dB	Analogue Outputs
56 (38h)	8:7		00	Reserved	
	6	OUT3MUTE	0	0 = Output stage outputs OUT3 mixer 1 = Output stage muted – drives out VMID. Can be used as VMID buffer in this mode.	Analogue Outputs
	5:4		00	Reserved. Initialise to 0	
	3	OUT4_2OUT3	0	OUT4 mixer output to OUT3 0 = disabled 1 = enabled	Analogue Outputs
	2	BYPL2OUT3	0	Left ADC input to OUT3 0 = disabled 1 = enabled	Analogue Outputs
	1	LMIX2OUT3	0	Left DAC mixer to OUT3 0 = disabled 1 = enabled	Analogue Outputs
	0	LDAC2OUT3	1	Left DAC output to OUT3 0 = disabled 1 = enabled	Analogue Outputs
57 (39h)	8		0	Reserved. Initialise to 0	
	7	OUT3_2OUT4	0	OUT3 mixer output to OUT4 0 = disabled 1 = enabled	Analogue Outputs
	6	OUT4MUTE	0	0 = Output stage outputs OUT4 mixer 1 = Output stage muted – drives out VMID. Can be used as VMID buffer in this mode.	Analogue Outputs
	5	HALFSIG	0	0=OUT4 normal output 1=OUT4 attenuated by 6dB	Analogue Outputs
	4	LMIX2OUT4	0	Left DAC mixer to OUT4 0 = disabled 1 = enabled	Analogue Outputs
	3	LDAC2OUT4	0	Left DAC to OUT4 0 = disabled 1 = enabled	Analogue Outputs

**WM8985**

Pre-Production

REGISTER ADDRESS	BIT	LABEL	DEFAULT	DESCRIPTION	REFER TO
	2	BYPR2OUT4	0	Right ADC input to OUT4 0 = disabled 1 = enabled	Analogue Outputs
	1	RMIX2OUT4	0	Right DAC mixer to OUT4 0 = disabled 1 = enabled	Analogue Outputs
	0	RDAC2OUT4	1	Right DAC output to OUT4 0 = disabled 1 = enabled	Analogue Outputs
61 (39h)	8		0	Global bias control 0 = normal 1 = 0.5x	Bias Control
	7:0		000 0000	Reserved. Initialise to 0	

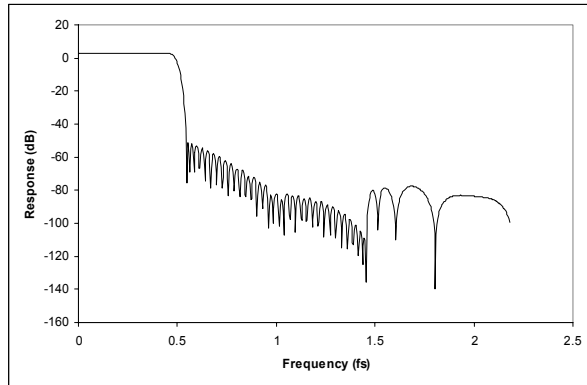
**DIGITAL FILTER CHARACTERISTICS**

PARAMETER	TEST CONDITIONS	MIN	TYP	MAX	UNIT
<b>ADC Filter</b>					
Passband	+/- 0.025dB	0		0.454fs	
	-6dB		0.5fs		
Passband Ripple				+/- 0.025	dB
Stopband		0.546fs			
Stopband Attenuation	f > 0.546fs	-60			dB
Group Delay			21/fs		
<b>ADC High Pass Filter</b>					
High Pass Filter Corner Frequency	-3dB		3.7		Hz
	-0.5dB		10.4		
	-0.1dB		21.6		
<b>DAC Filter</b>					
Passband	+/- 0.035dB	0		0.454fs	
	-6dB		0.5fs		
Passband Ripple				+/-0.035	dB
Stopband		0.546fs			
Stopband Attenuation	f > 0.546fs	-55			dB
Group Delay			29/fs		

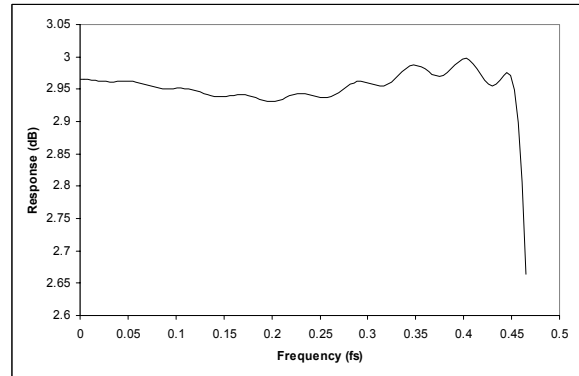
**Table 54 Digital Filter Characteristics****TERMINOLOGY**

1. Stop Band Attenuation (dB) – the degree to which the frequency spectrum is attenuated (outside audio band)
2. Pass-band Ripple – any variation of the frequency response in the pass-band region

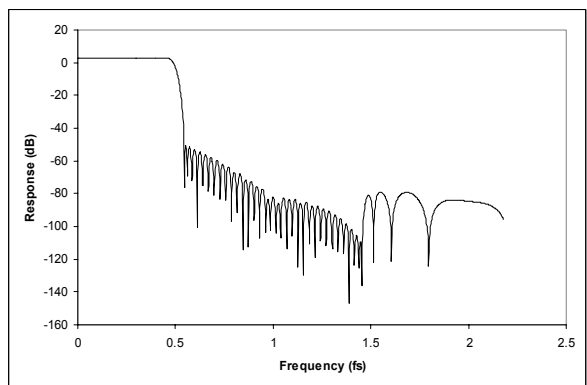
**DAC FILTER RESPONSES**



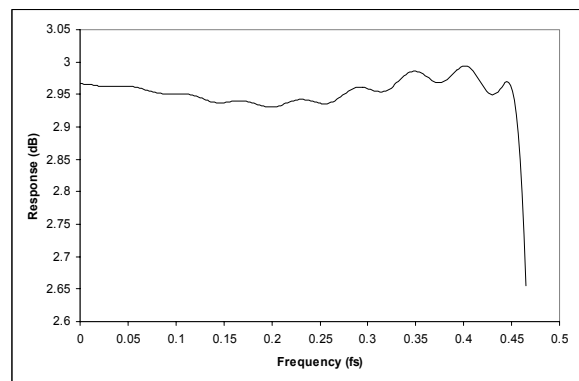
**Figure 40 DAC Digital Filter Frequency Response (128xOSR)**



**Figure 41 DAC Digital Filter Ripple (128xOSR)**

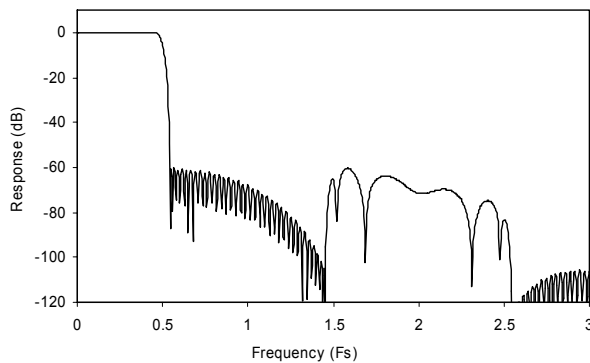


**Figure 42 DAC Digital Filter Frequency Response (64xOSR)**

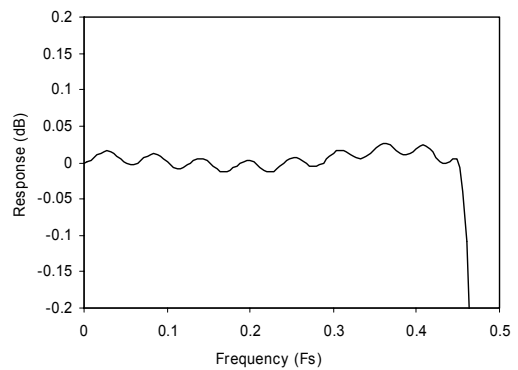


**Figure 43 DAC Digital Filter Ripple (64xOSR)**

**ADC FILTER RESPONSES**



**Figure 44 ADC Digital Filter Frequency Response**



**Figure 45 ADC Digital Filter Ripple**

### HIGHPASS FILTER

The WM8985 has a selectable digital highpass filter in the ADC filter path. This filter has two modes, audio and applications. In audio mode the filter is a 1<sup>st</sup> order IIR with a cut-off of around 3.7Hz. In applications mode the filter is a 2<sup>nd</sup> order high pass filter with a selectable cut-off frequency.

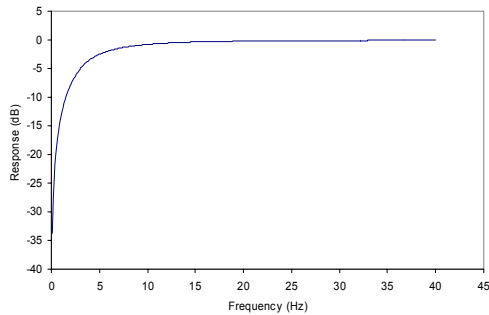


Figure 46 ADC Highpass Filter Response, HPFAPP=0

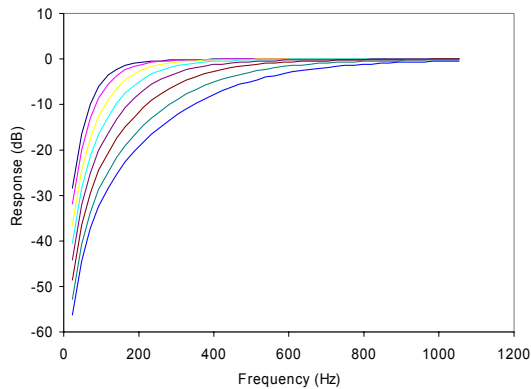


Figure 47 ADC Highpass Filter Responses (48kHz), HPFAPP=1, all cut-off settings shown

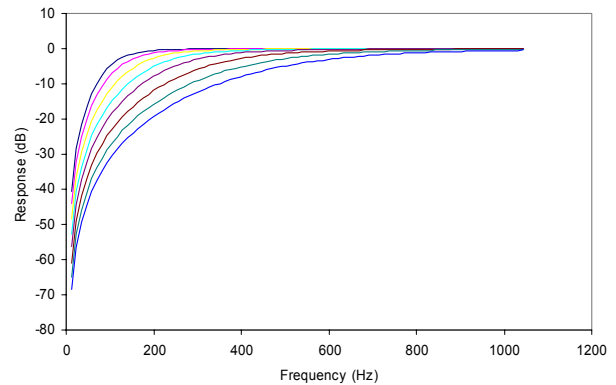


Figure 48 ADC Highpass Filter Responses (24kHz), HPFAPP=1, all cut-off settings shown

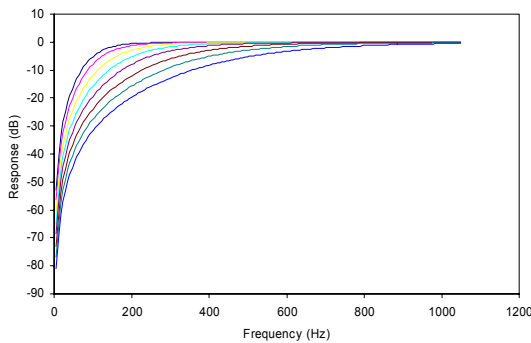


Figure 49 ADC Highpass Filter Responses (12kHz), HPFAPP=1, all cut-off settings shown

### 5-BAND EQUALISER

The WM8985 has a 5-band equaliser which can be applied to either the ADC path or the DAC path. The plots from Figure 50 to Figure 63 show the frequency responses of each filter with a sampling frequency of 48kHz, firstly showing the different cut-off/centre frequencies with a gain of  $\pm 12$ dB, and secondly a sweep of the gain from -12dB to +12dB for the lowest cut-off/centre frequency of each filter.

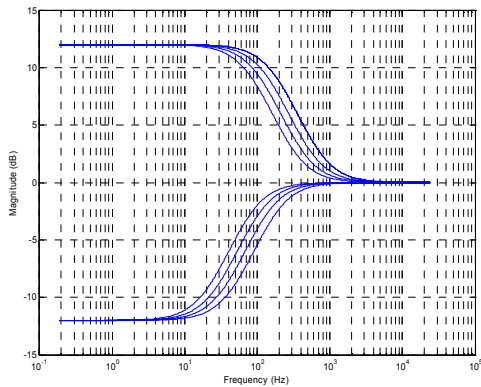


Figure 50 EQ Band 1 Low Frequency Shelf Filter Cut-offs

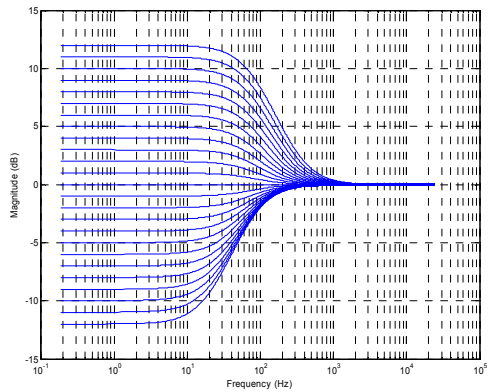


Figure 51 EQ Band 1 Gains for Lowest Cut-off Frequency

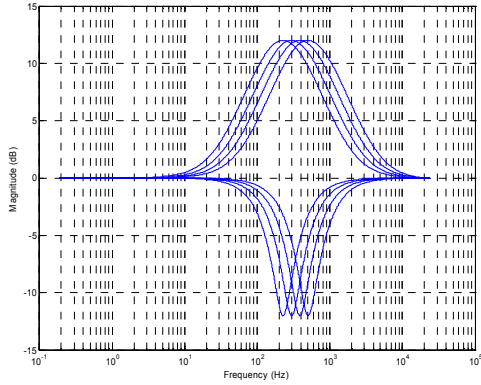


Figure 52 EQ Band 2 - Peak Filter Centre Frequencies, EQ2BW=0

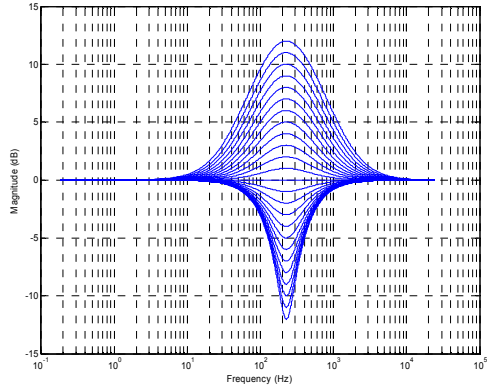


Figure 53 EQ Band 2 - Peak Filter Gains for Lowest Cut-off Frequency, EQ2BW=0

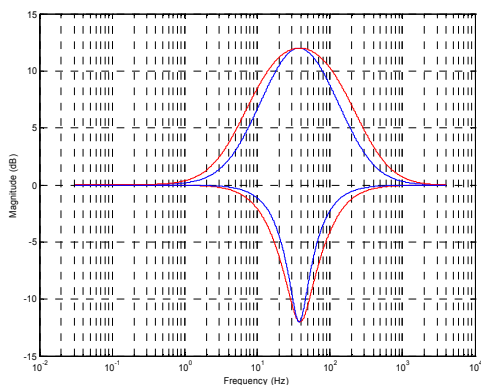


Figure 54 EQ Band 2 - EQ2BW=0, EQ2BW=1

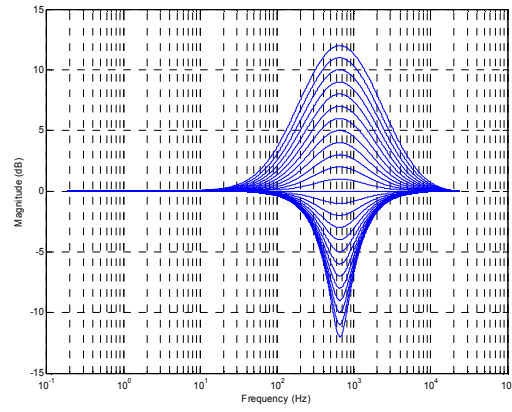
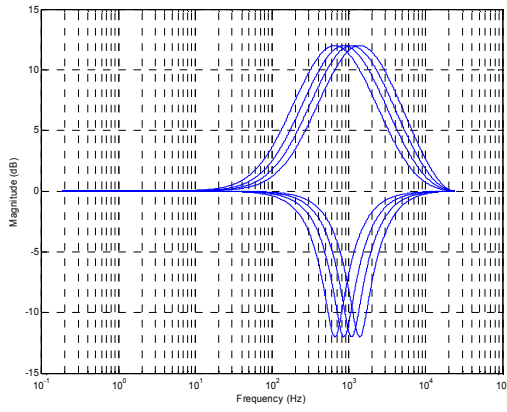


Figure 55 EQ Band 3 – Peak Filter Centre Frequencies, EQ3! Figure 56 EQ Band 3 – Peak Filter Gains for Lowest Cut-off Frequency, EQ3BW=0

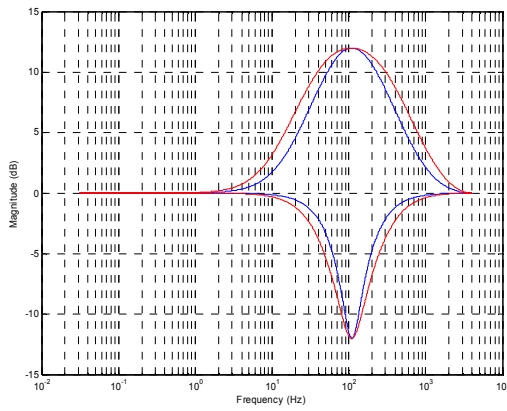


Figure 57 EQ Band 3 – EQ3BW=0, EQ3BW=1

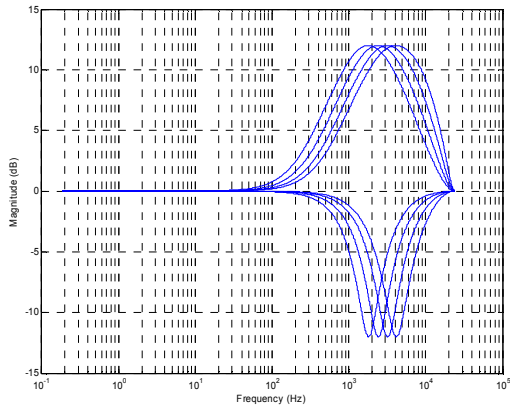


Figure 58 EQ Band 4 – Peak Filter Centre Frequencies, EQ3BW=0

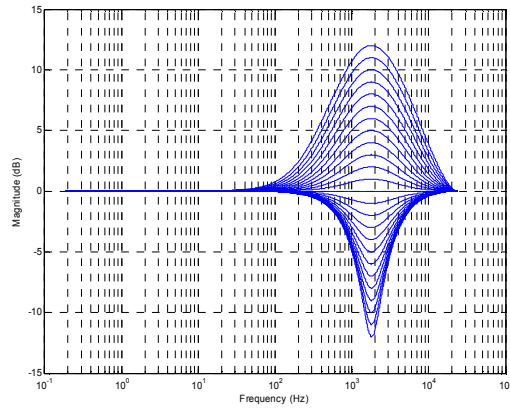


Figure 59 EQ Band 4 – Peak Filter Gains for Lowest Cut-off Frequency, EQ4BW=0

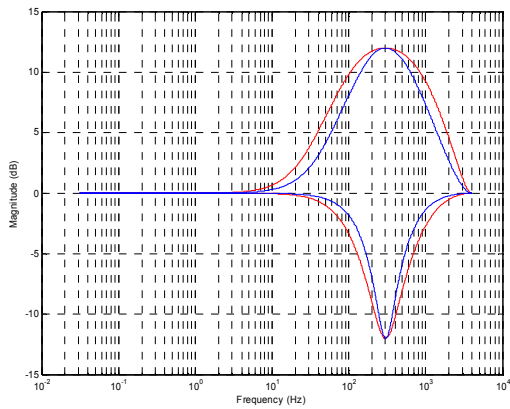


Figure 60 EQ Band 4 – EQ3BW=0, EQ3BW=1

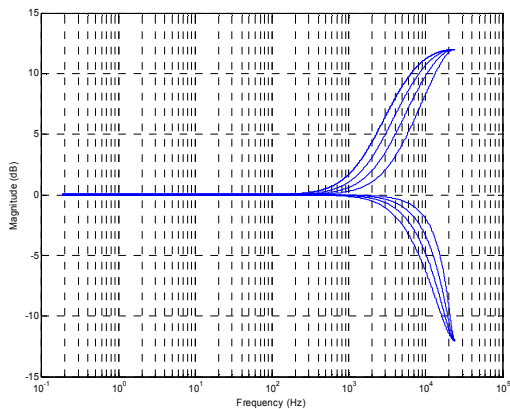


Figure 61 EQ Band 5 High Frequency Shelf Filter Cut-offs

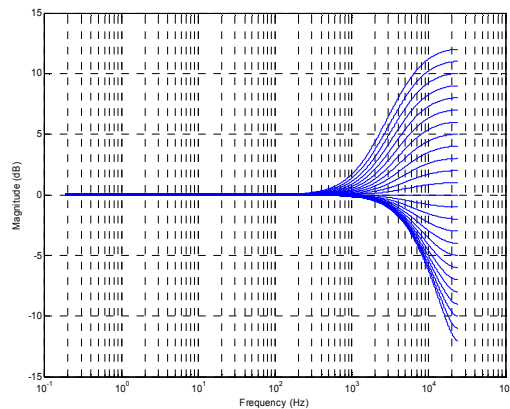


Figure 62 EQ Band 5 Gains for Lowest Cut-off Frequency

Figure 63 shows the result of having the gain set on more than one channel simultaneously. The blue traces show each band (lowest cut-off/centre frequency) with  $\pm 12\text{dB}$  gain. The red traces show the cumulative effect of all bands with  $+12\text{dB}$  gain and all bands  $-12\text{dB}$  gain, with  $\text{EqxBW}=0$  for the peak filters.

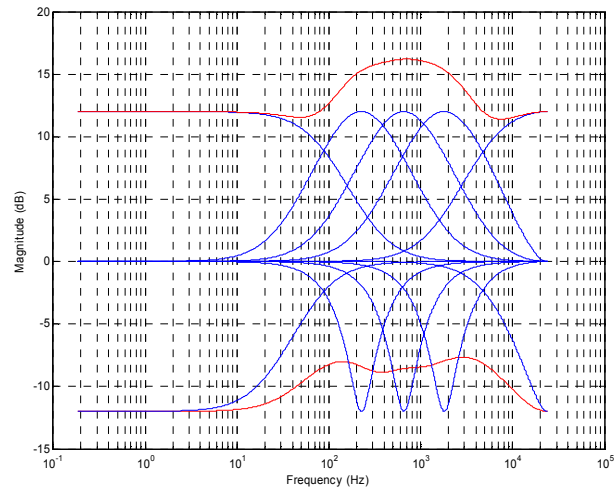


Figure 63 Cumulative Frequency Boost/Cut

## APPLICATIONS INFORMATION

## RECOMMENDED EXTERNAL COMPONENTS

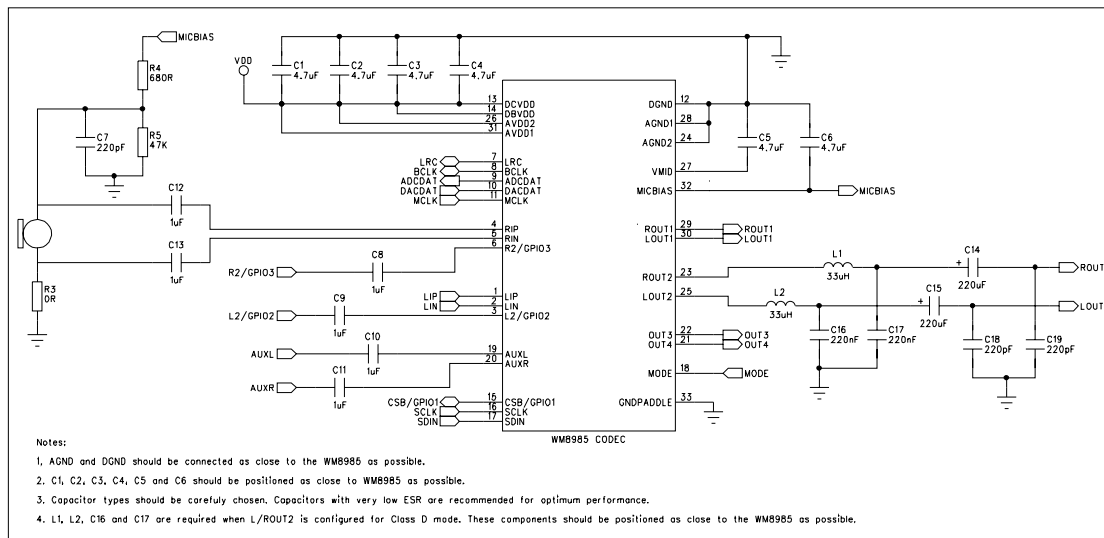
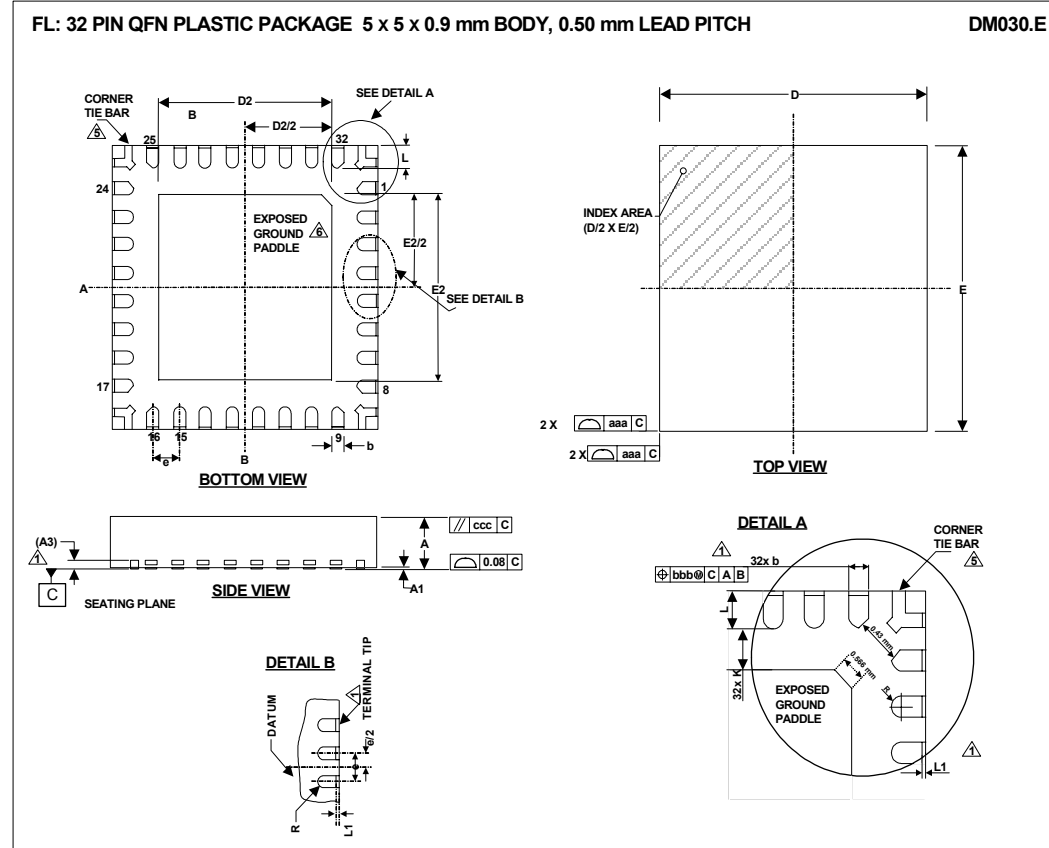


Figure 64 External Component Diagram

1. When operating LOUT2 and ROUT2 in class D mode, it is recommended that LC filtering is placed as close to the LOUT2 and ROUT2 pins as possible. Low ESR components should be used for maximum efficiency. It is recommended that a filter, consisting of a 33 $\mu$ H inductor and a 220nF capacitor, is used for optimal performance.
2. The addition of ferrite beads to the outputs of LOUT2 and ROUT2 will suppress any potential interference noise produced by the class D switching clocks.

## PACKAGE DIAGRAM



Symbols	Dimensions (mm)			NOTE
	MIN	NOM	MAX	
A	0.85	0.90	1.00	
A1	0	0.02	0.05	
A3		0.2 REF		
b	0.18	0.23	0.30	1
D	4.90	5.00	5.10	
D2	3.2	3.3	3.4	2
E	4.90	5.00	5.10	
E2	3.2	3.3	3.4	2
e		0.5 BSC		
L	0.35	0.4	0.45	
L1			0.1	1
R	b(min)/2			
K	0.20			
<b>Tolerances of Form and Position</b>				
aaa	0.15			
bbb	0.10			
ccc	0.10			
REF:	JEDEC, MO-220, VARIATION VHHD-2			

- NOTES:
- DIMENSION b APPLIED TO METALLIZED TERMINAL AND IS MEASURED BETWEEN 0.25 mm AND 0.30 mm FROM TERMINAL TIP. DIMENSION L1 REPRESENTS TERMINAL PULL BACK FROM PACKAGE SIDE WALL. MAXIMUM OF 0.1mm IS ACCEPTABLE. WHERE TERMINAL PULL BACK EXISTS, ONLY UPPER HALF OF LEAD IS VISIBLE ON PACKAGE SIDE WALL DUE TO HALF ETCHING OF LEADFRAME.
  - FALLS WITHIN JEDEC, MO-220 WITH THE EXCEPTION OF D2, E2.  
D2, E2: LARGER PAD SIZE CHOSEN WHICH IS JUST OUTSIDE JEDEC SPECIFICATION
  - ALL DIMENSIONS ARE IN MILLIMETRES
  - THIS DRAWING IS SUBJECT TO CHANGE WITHOUT NOTICE.
  - SHAPE AND SIZE OF CORNER TIE BAR MAY VARY WITH PACKAGE TERMINAL COUNT. CORNER TIE BAR IS CONNECTED TO EXPOSED PAD INTERNALLY.
  - REFER TO APPLICATION NOTE WAN\_0118 FOR FURTHER INFORMATION REGARDING PCB FOOTPRINTS AND QFN PACKAGE SOLDERING.

---

## IMPORTANT NOTICE

Wolfson Microelectronics plc ("Wolfson") products and services are sold subject to Wolfson's terms and conditions of sale, delivery and payment supplied at the time of order acknowledgement.

Wolfson warrants performance of its products to the specifications in effect at the date of shipment. Wolfson reserves the right to make changes to its products and specifications or to discontinue any product or service without notice. Customers should therefore obtain the latest version of relevant information from Wolfson to verify that the information is current.

Testing and other quality control techniques are utilised to the extent Wolfson deems necessary to support its warranty. Specific testing of all parameters of each device is not necessarily performed unless required by law or regulation.

In order to minimise risks associated with customer applications, the customer must use adequate design and operating safeguards to minimise inherent or procedural hazards. Wolfson is not liable for applications assistance or customer product design. The customer is solely responsible for its selection and use of Wolfson products. Wolfson is not liable for such selection or use nor for use of any circuitry other than circuitry entirely embodied in a Wolfson product.

Wolfson's products are not intended for use in life support systems, appliances, nuclear systems or systems where malfunction can reasonably be expected to result in personal injury, death or severe property or environmental damage. Any use of products by the customer for such purposes is at the customer's own risk.

Wolfson does not grant any licence (express or implied) under any patent right, copyright, mask work right or other intellectual property right of Wolfson covering or relating to any combination, machine, or process in which its products or services might be or are used. Any provision or publication of any third party's products or services does not constitute Wolfson's approval, licence, warranty or endorsement thereof. Any third party trade marks contained in this document belong to the respective third party owner.

Reproduction of information from Wolfson datasheets is permissible only if reproduction is without alteration and is accompanied by all associated copyright, proprietary and other notices (including this notice) and conditions. Wolfson is not liable for any unauthorised alteration of such information or for any reliance placed thereon.

Any representations made, warranties given, and/or liabilities accepted by any person which differ from those contained in this datasheet or in Wolfson's standard terms and conditions of sale, delivery and payment are made, given and/or accepted at that person's own risk. Wolfson is not liable for any such representations, warranties or liabilities or for any reliance placed thereon by any person.

### ADDRESS:

Wolfson Microelectronics plc  
Westfield House  
26 Westfield Road  
Edinburgh  
EH11 2QB  
United Kingdom

Tel :: +44 (0)131 272 7000  
Fax :: +44 (0)131 272 7001  
Email :: sales@wolfsonmicro.com