

查询8575供应商

捷多邦 专业

8575-6623

FILTRAN

## Chokes

Data Communication Circuits

, 24小时加急出货

General purpose pulse transformers.

These units can be used in common applications such as:

- isolating
- line coupling
- matching
- some can be used as common mode chokes



Mechanical (All dimensions in mm)

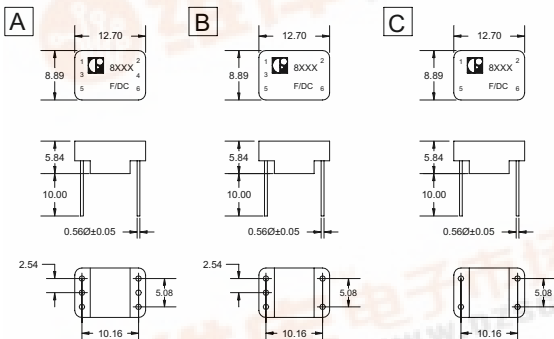

SCHEMATIC / PIN LAYOUT (TOP VIEW)

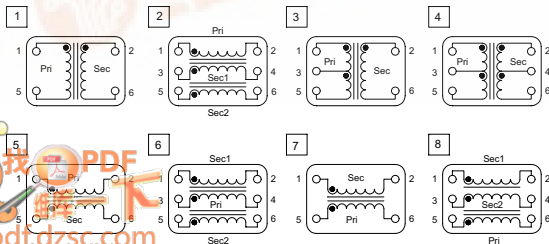

8575-6623



See page 2 for electrical specifications.

## Electrical Specifications @ 25°C

Part Number	Turns Ratio (±2%)	Primary Inductance (μH MIN)	Leakage Inductance (μH MAX)	Interwinding Capacitance (pF MAX)	DCR Ω	Pin Layout	Mechanical Dimensions
8575	1:1	9.5	0.20	10	0.40	1	C
8576	4:1	9.5	1.20	5.0	0.40		
8577	1:1	20.1	0.20	5.0	0.20		
8578	1:1	23	0.20	8.0	0.30		
8579	2:1	23	0.40	10	0.30		
8580	1:1	50	0.20	10	0.40		
8580-1	1:1	33	0.40	20	0.05		
8581	4:1	90	1.00	5.0	0.40		
8582	1:1	219	0.25	12	0.50		
8583	3:1	251	1.00	5.0	0.50		
8584	1:1	492	0.30	20	0.80		
8585	1:1	850	0.30	50	0.30		
8586	1:1	938	0.20	35	0.15		
8587	1:1	1000	0.30	25	0.30		
8588	2:1	1970	1.60	20	1.50		
8589	1:1	2060	0.60	35	1.50		
8590	4:1	2160	2.80	12	1.50		
8591	1:1	4000	0.60	45	1.50		
8592	1:1	11mH	65.0	5.0	5.00		
8593	1:1	11.7mH	0.40	80	1.35		
8594	1:1:1	9.5	0.20	10	0.40		
8595	1:1:1	23	0.20	8.0	0.30		
8596	1:1:1	219	0.25	12	0.50		
8597	1:1:1	469	3.50	3.0	0.40		
8598	1:1:1	492	0.30	20	0.80		
8599	1:1:1	2060	0.60	35	1.50		
8600	1:1:1	5870	0.90	60	1.70		
8601	2CT:1	125	0.50	12	0.50		
8602	1CT:1	219	0.30	13	0.60		
8603	2CT:1	415	0.20	15	0.30		
8604	1CT:1	540	0.40	22	0.90		
8605	2CT:1	1970	0.70	35	1.50		
8606	1CT:1	1970	1.00	36	1.60		
8607	1CT:1CT	400	85.0	3	0.30		
8608	2CT:1CT	1710	3.00	20	1.00		
8609	1CT:2CT	1800	1.00	20	1.00		
8610	1CT:1CT	3200	2.00	27	1.00		
8611	2CT:1CT	4350	3.00	20	1.00		
8612	1CT:2CT	7600	0.80	25	1.80		
8613	1:1	50	0.20	10	0.40		
8614	1:1	219	0.25	12	0.50		
8615	1:1	492	0.30	20	0.80		
8616	1:1	2060	0.60	35	1.50		
8617	2:1:1	9.5	0.40	8	0.40		
8618	2:1:1	540	0.80	10	0.80		
8619	2:1:1	1020	2.00	30	1.50		
8620	2:1:1	2160	1.60	20	1.50		
8621	2:1	219	0.60	8	0.50		
8622	3:1	1970	1.80	15	1.50		
8623	3:3:2	400	0.50	15	0.20		
						5	C
						6	A
						7	C
						8	A