

REVISION FOR DWG # 1PB-AMLKBx

REV	CH.NO.	DESCRIPTION	DATE	REVISED BY
-	-	ORIGINAL DESIGN	11/20/2007	PHILIPP E.

查询AMLKBX供应商

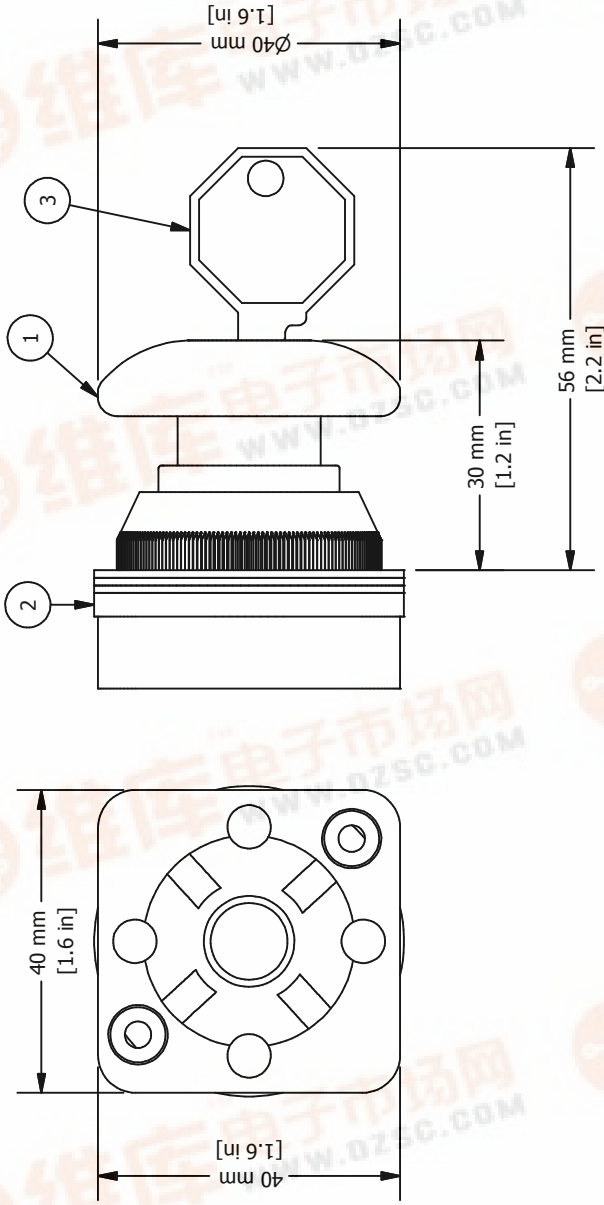

捷多邦, 专业PCB打样工厂, 24小时加急服务

\* = Operator includes 3x ARW1.2, 1x ARW3.2 and 1x Key  
 \*\* = Switch Contacts include Contact element washer and two SC24 installation screws, if more than two contact blocks are used, additional screws must be purchased separately (SC45, SC65 or SC90)

ITEM	DESCRIPTION	CAT. NO.	COLOR	MIN. QTY.	MAX. QTY.
1*	30 mm Non-Illuminated Mushroom Metal Operator	AMLKB2 AMLKB4	Black Red	1	1
2*	Rubber washer	AMKB2 AMKB4	Black Red	1	1
3*	Key	ARW1.2/ARW3.2	Black	1	1
4	Panel	-	-	-	-
5**	Contact Element washer	-	Black	1	1
6**	Switch Contacts	S11	Red	1	1
7**	Switch Contacts	S12	Yellow	1	1
8**	Contact Block Installation Screws	SC25/SC45/SC65/SC90	-	-	2

TITLE 30 mm Non-Illuminated Mushroom Metal Operator AMLKBx and AMKBx (x=color)

AND IS A CONFIDENTIAL DISCLOSURE WITHOUT CONSIDERATION OTHER THAN THE BORROWER'S AGREEMENT THAT IT SHALL NOT BE REPRODUCED, COPIED, LENT OR DISPOSED OF DIRECTLY OR INDIRECTLY NOR USED FOR ANY PURPOSE OTHER THAN THAT FOR WHICH IT IS SPECIFICALLY FURNISHED.

This Drawing is the property of **Altech Corp.**  
 35 Royal Road  
 Flemington, NJ 08822-6000  
 (908) 806-9400  
 Fax (908) 806-9490

UNLESS OTHERWISE SPECIFIED: DIMENSIONS ARE IN MILLIMETERS  
 THIRD ANGLE PROJECTION  
 METRIC  
 TOLERANCE = ±1 mm  
 X = ±0.5 mm  
 .XX = ±0.2 mm  
 L = - mm

DRAWN BY: Philipp Ernstberger  
 CHECKED BY: Laszlo Gyorgypal  
 RELEASED BY: Laszlo Gyorgypal  
 DRAWING NO.: 1PB-AMLKBx  
 REV.: -  
 SCALE: -  
 SHEET: 1 OF: 1

