

INVERSEURS DE SENS DE ROTATION MOTOR REVERSER

SG969100

**3x400VAC 3KW
Three legs model**

Le relais SG969100 (moteur 3kW max sous 400VAC) avec la coupure des 3 phases et l'inversion de 2 , peut être commandé avec une entrée type PNP (automates européens) avec ou sans tension de commande . Ce modèle dispose en plus d'une sortie donnant l'information de fonctionnement du relais dans l'un ou l'autre sens , d'une temporisation réglage entre chaque sens de rotation . Elle peut permettre en particulier de piloter un relais de type SOFT-START (voir dernière page) .

The SG969100 (max 3Kw motor /400VAC) relay with the commutation of the 3 phases and the reversing of 2 , has the special feature of a PNP type control , with or without V+ power supply , an output capable of controlling an SMC9 soft-start relay (see last page) and a independent setting for each rotation direction .



Dimensions / Dimensions:

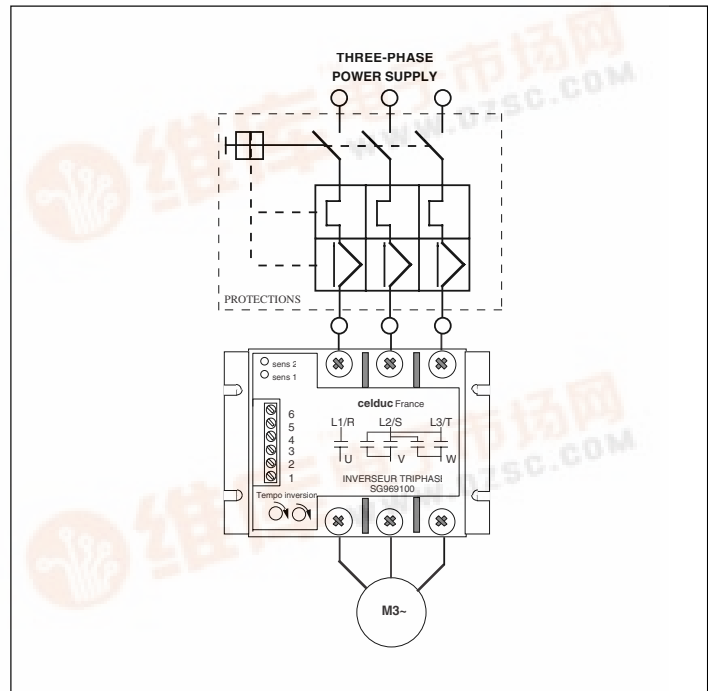
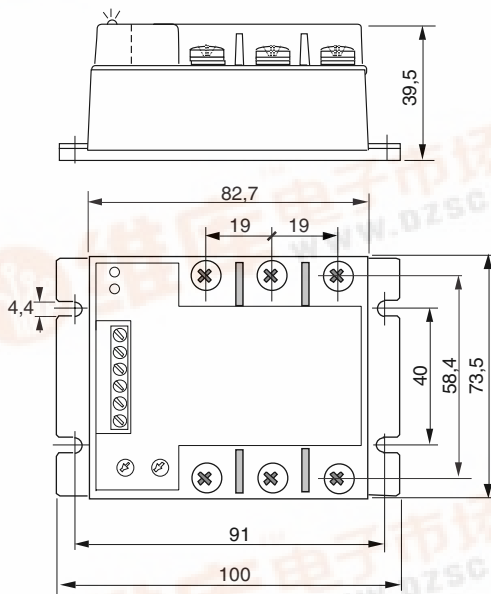

Circuit équivalent/Equivalent circuit :

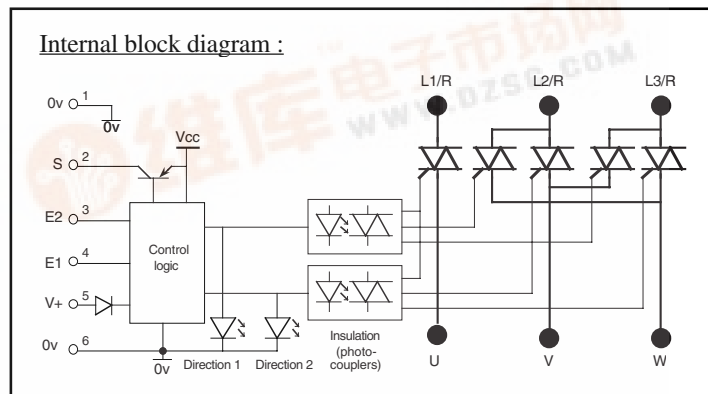

Capot de protection/
Cover : reference **1K199000**

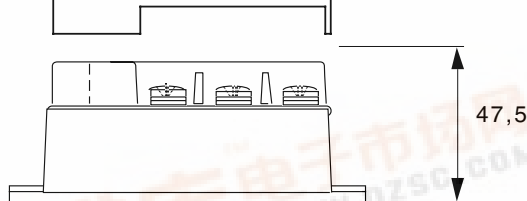

Designed in compliance with standards:

->EN60947-4-2 (V.D.E. 0660 part 109, I.E.C. 158-2)

->EN60947-1 & A11

->EN60950 (V.D.E. 0805-> office equipment) (Pending approval)

->U.L. 508 (Pending approval) ->c.U.L (Pending approval)

Control	Plage de tension de commande / <i>Control voltage range</i>	Uc	12-30VDC
	Plage de courant de commande / <i>Control current range</i>	Ic	13-31mA
	Tension de non fonctionnement / <i>Release voltage</i>	Ur	7VDC
	LED de visualisation / <i>Display LED</i>		Yes
	protection en cas de cdes simultanées / <i>protection against simultaneous controls</i>		Yes
	tension inverse maxi / <i>Maximum reverse voltage</i>	Urv	30V
	Signal de sortie / <i>Output signal</i>	S (pin2)	max 60VDC 50mA
	temporisation inversion / <i>Reversing time</i>		adjustable 0,06 to 4s

Examples of possible controls

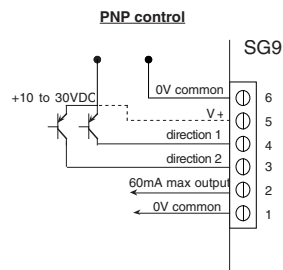
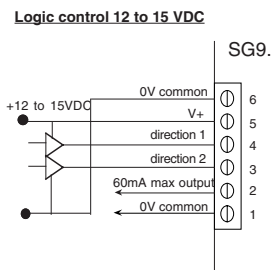
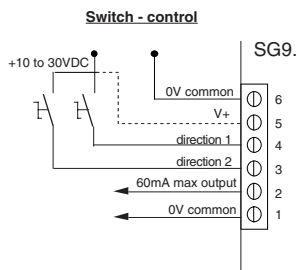

Input diagram :

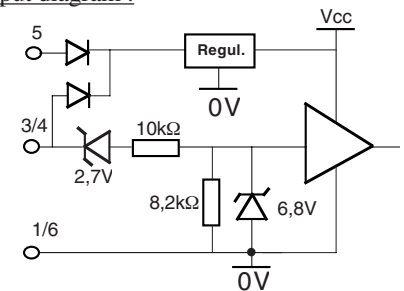

Brochage du bornier de commande:

BORNE	DESIGNATION
1	0v COMMUN
2	SORTIE PNP
3	ENTREE SENS 2
4	ENTREE SENS 1
5	ENTREE V+
6	0v COMMUN

Pin arrangement on control terminal strip :

TERMINAL	DESCRIPTION
1	0V COMMON
2	60mA OUTPUT SUPPLY
3	DIRECTION 2 INPUT
4	DIRECTION 1 INPUT
5	V+ INPUT
6	0V COMMON

Examples of time diagrams

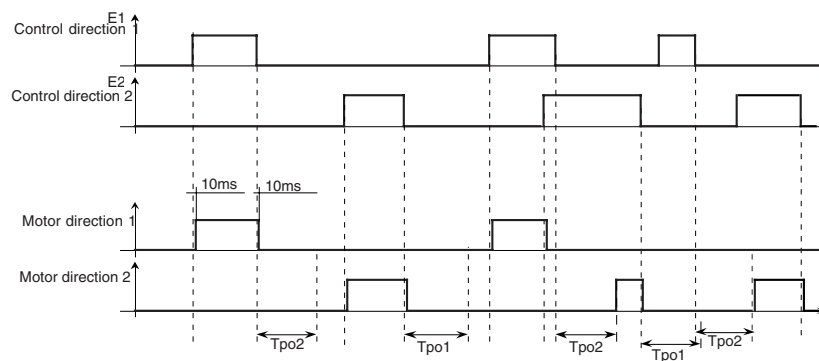

Tpo1 : Inversion time from the direction 2 to the direction 1 : 70ms
 Tpo2 : Inversion time from the direction 1 to the direction 2 : 70ms

Caractéristiques d'entrée-sortie (à 20°C) / *Input-output characteristics (at 20°C)*

				Unit
Isolement entrée-sortie/ <i>Input-output isolation @500m</i>	Ui	4000		VRMS
Isolement sortie-semelle/ <i>Output-case isolation @500m</i>	Ui	2500		VRMS
Tension assignée isolement/rated impulse voltage	Uimp	4000		V

Caractéristiques générales / *General characteristics*

			Unit
Poids/ <i>Weight</i>		130g	g
Plage de température de stockage / <i>Storage temperature range</i>		-40 / +100	°C
Plage de température de fonctionnement/ <i>Operating temperature range</i>		-40 / +100	°C



ISO 9001
N° 1993/1106a

celduc[®]
relais

www.celduc.com

Rue Ampère B.P. 4

42290 SORBIERS - FRANCE

E-Mail : celduc-relais@celduc.com

Fax +33 (0) 4 77 53 85 51

Service Commercial France Tél. : +33 (0) 4 77 53 90 20

Sales Dept For Europe Tel. : +33 (0) 4 77 53 90 21

Sales Dept Asia : Tél. +33 (0) 4 77 53 90 19

Output	Tension nominale/ <i>Standard mains voltage</i>	Ue	400 VAC
	Plage de tension de fonctionnement / <i>Mains voltage range</i>	Un	24-500VAC
	tension crête non répétitive/ <i>Non-repetitive maximum peak voltage</i>	Up	1200V
	Courant AC-53 maxi/ <i>Max. nom. current (AC53a=AC3) @40°C</i>	Ie	6,6
	Puissance moteur/ <i>3 pole power motor (3x400VAC)</i>	Pn	3kW
	Chute directe / <i>Max Direct voltage drop (@Ie)</i>	Ud	1,4VRMS
	Courant crête non répétitif/ <i>Non repetitive overload current (@ 1 cycle of 10ms)</i>	ITSM	350A
	I _{2t} value/ <i>Melting limit (choice of fuse) @10ms</i>	I ² _t	612 A ² s
	Courant minimal de charge / <i>Minimum load current</i>	I _{min}	100 mA
	facteur de puissance/ <i>Power factor (@ Ith)</i>	Pf	0 up to 1
	Temps d'ouverture et de temporisation/ <i>Turn on time-reversing time(@50Hz)</i>	ton/trv	10ms /adjustable
	Temps d'ouverture/ <i>Turn off time (@50Hz)</i>	toff	10ms
	Courant de fuite / <i>Maximum leakage current (@Ue/50Hz)</i>	I _{lk}	5 mARMS
	dv/dt / <i>Max off state voltage rise</i>	dv/dt	500V/μs
	Fréquence de réseau / <i>Operating frequency range</i>	f	25 up to 440Hz

E.M.C.	Max conducted immunity level Test accord. to I.E.C.1000-4-4 (bursts)		4KV direct at output, 4KV with a clamp at input no turn on or damage
	Max conducted immunity level Test acc. to I.E.C.1000-4-5 (el. shocks)		2KV in common mode, 1KV in differential mode (Input & output) no turn on or damage
	Max radiated immunity level Test accord. to I.E.C.1000-4-3		10V/m no turn on or damage
	Max electrostatic disch. immunity level Test accord. to I.E.C.1000-4-2		8KV in the air / 4KV touching no turn on or damage
	Max conducted emission level (0,8<Pf<1) Test according to EN55011		The conducted noise made by SSR depends on the wiring configuration and the load type. Test methods recommended by European E.M.C. standards giving results far from reality, we have chosen to advise the right filter suited for the customer's use: Refer to EMC chapter
	Max radiated emission level Test accord. to EN55011 @Ie		<30dBμV from 30 up to 230MHz ; <37dBμV from 230 up to 1000MHz

Misc.	Base/junction thermal resistance	R _{thjc}	1,1K/W (1 leg)
	Ambient/junction thermal resistance (relay mounted vertically)	R _{thja}	5K/W
	Weight		130g

Characteristics given at 25°C unless otherwise specified

☞ Must be used only in conjunction with a heatsink mounted in vertical position to help the air flow. Minimum air distances all around the heatsink : 10mm.

☞ Doit être utilisé obligatoirement monté sur dissipateur thermique placé en position verticale afin de faciliter la circulation de l'air. Distances minimum dans l'air autour du dissipateur : 10mm

MONTAGE D'UN RELAIS
Mounting of a relay on a heatsink

M4 x 12mm
1,5N.m

91,5mm

40mm

M4 x 12mm
1,5N.m

Use heat conducting paste.
Utiliser de la graisse thermoconductrice.

☞ Connect to protective ground.
☞ Connecter au conducteur de protection



ISO 9001
N° 1993/1106a

celduc[®]
r e l a i s

Rue Ampère B.P. 4

42290 SORBIERS - FRANCE

E-Mail : celduc-relais@celduc.com

Fax +33 (0) 4 77 53 85 51

Service Commercial France Tél. : +33 (0) 4 77 53 90 20

Sales Dept For Europe Tel. : +33 (0) 4 77 53 90 21

Sales Dept Asia : Tél. +33 (0) 4 77 53 90 19

Caractéristiques thermiques / Thermal curves :

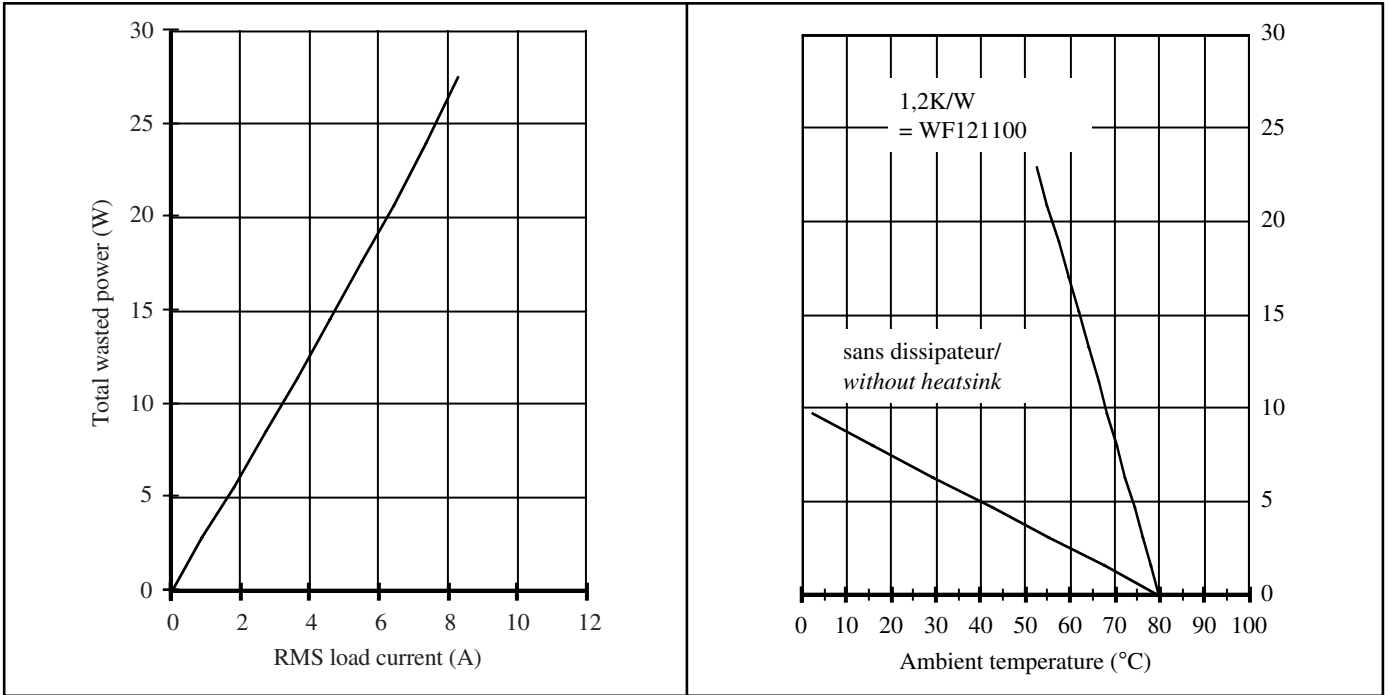

Courant de surcharge non répétitif :ITSM

/ Non repetitive surge peak on-state current : ITSM

Fig.3 Surcharge de courant : $I_{tsm} (A_{peak}) = f(t)$ pour modèle 40A ($I_{tsm}=350A$)
 Surge current : $I_{tsm} (A_{peak}) = f(t)$ for 40A models with $I_{tsm} =350A$

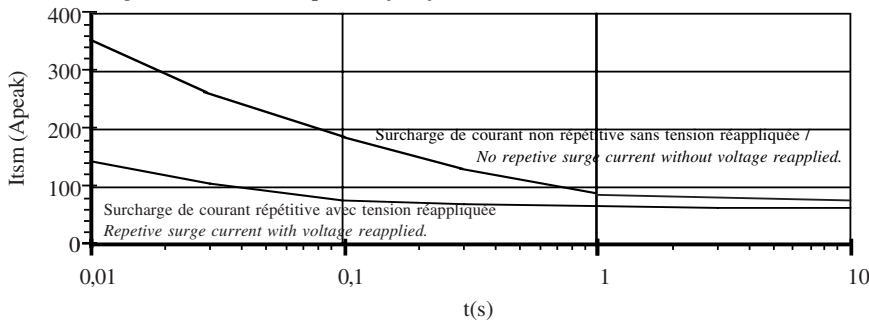

REVERSERS + HEATSINK SELECTION IN COMPLIANCE WITH EN60947-4-2

SSR SELECTION motors soft-staters for a permanent current		Relays without heatsink	Heatsink ^{amb} - ambient =40°C - heatsink =80°C	Ferraz fuse type 14x51 size / max. rating	Overload relay type Klöckner-Moeller
Motor power	In motor (@ 400V)	three legs models 40A	with integrated DIN RAIL adaptor	sans protection court-circuit / no protection in case of short circuit (*)	
0,75 kW	2A	SG969100	none	am 8A/500V	Z00-2.4
1,1 kW	2,6A	SG969100	none	am 8A/500V	Z00-6
1,5 kW	3,5A	SG969100	none	am 12A/500V	Z00-6
2,2 kW	5A	SG969100	WF121000	am 12A/500V	Z00-6
3 kW	6,6A	SG969100	WF121000	am 12A/500V	Z00-10
4 kW	8,5A	-	WF121000	am 12A/500V	Z00-10

(*) : Pour une protection court-circuit correcte des relais : utiliser les SG969300

(*) : For a better protection against short-circuit use SG969300



SG969100 + SMC93xxx
The SSR reversers can drive directly
the soft-start .



+

