

bq27545-G1 Single-Cell Li-Ion Battery Fuel Gauge For Battery Pack Integration

1 Features

- Battery Fuel Gauge for 1-Series (1sXp) Li-Ion Applications up to 14500-mAh Capacity
- Microcontroller Peripheral Provides:
 - Internal or External Temperature Sensor for Battery Temperature Reporting
 - SHA-1/HMAC Authentication
 - Lifetime Data Logging
 - 64 Bytes of Non-Volatile Scratch Pad FLASH
- Battery Fuel Gauging Based on Patented Impedance Track™ Technology
 - Models Battery Discharge Curve for Accurate Time-To-Empty Predictions
 - Automatically Adjusts for Battery Aging, Battery Self-Discharge, and Temperature and Rate Inefficiencies
 - Low-Value Sense Resistor (5 mΩ to 20 mΩ)
- Advanced Fuel Gauging Features
 - Internal Short Detection
 - Tab Disconnection Detection
- HDQ and I²C™ Interface Formats for Communication with Host System
- Small 15-ball Nano-Free™ (DSBGA) Packaging

2 Applications

- Smartphones
- Tablets
- Digital Still and Video Cameras
- Handheld Terminals
- MP3 or Multimedia Players

4 Simplified Schematic

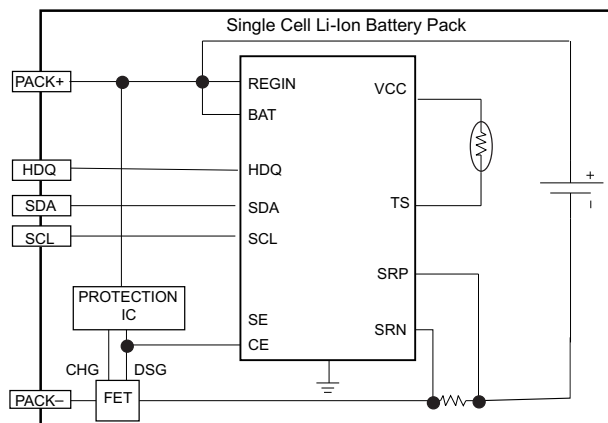

3 Description

The bq27545-G1 Li-ion battery fuel gauge is a microcontroller peripheral that provides fuel gauging for single-cell Li-ion battery packs. The device requires little system microcontroller firmware development for accurate battery fuel gauging. The bq27545-G1 resides within the battery pack or on the system's main-board with an embedded battery (non removable).

The bq27545-G1 uses the patented Impedance Track™ algorithm for fuel gauging, and provides information such as remaining battery capacity (mAh), state-of-charge (%), run-time to empty (minimum), battery voltage (mV), and temperature (°C). It also provides detections for internal short or tab disconnection events.

The bq27545-G1 also features integrated support for secure battery pack authentication, using the SHA-1/HMAC authentication algorithm.

The device comes in a 15-ball Nano-Free™ DSBGA package (2.61 mm × 1.96 mm) that is ideal for space constrained applications.

Device Information⁽¹⁾

PART NUMBER	PACKAGE	BODY SIZE (NOM)
bq27545-G1	YZF (15)	2.61 mm × 1.96 mm

(1) For all available packages, see the orderable addendum at the end of the data sheet.



Table of Contents

1	Features	1	8.15	Typical Characteristics	9
2	Applications	1	9	Detailed Description	10
3	Description	1	9.1	Overview	10
4	Simplified Schematic	1	9.2	Functional Block Diagram	11
5	Revision History	2	9.3	Feature Description	11
6	Device Comparison Table	3	9.4	Device Functional Modes	16
7	Pin Configuration and Functions	3	9.5	Programming	24
8	Specifications	4	9.6	Register Maps	39
8.1	Absolute Maximum Ratings	4	10	Application and Implementation	41
8.2	ESD Ratings	4	10.1	Application Information	41
8.3	Recommended Operating Conditions	4	10.2	Typical Application	41
8.4	Thermal Information	4	11	Power Supply Recommendations	45
8.5	Electrical Characteristics: Supply Current	5	11.1	Power Supply Decoupling	45
8.6	Electrical Characteristics: Digital Input and Output DC	5	12	Layout	45
8.7	Electrical Characteristics: Power-On Reset	5	12.1	Layout Guidelines	45
8.8	Electrical Characteristics: 2.5-V LDO Regulator	5	12.2	Layout Example	46
8.9	Electrical Characteristics: Internal Clock Oscillators	6	13	Device and Documentation Support	47
8.10	Electrical Characteristics: Integrating ADC (Coulomb Counter) Characteristics	6	13.1	Documentation Support	47
8.11	Electrical Characteristics: ADC (Temperature and Cell Voltage)	6	13.2	Community Resources	47
8.12	Electrical Characteristics: Data Flash Memory	6	13.3	Trademarks	47
8.13	HDQ Communication Timing Characteristics	7	13.4	Electrostatic Discharge Caution	47
8.14	I ² C-Compatible Interface Timing Characteristics	7	13.5	Glossary	47
			14	Mechanical, Packaging, and Orderable Information	47

5 Revision History

NOTE: Page numbers for previous revisions may differ from page numbers in the current version.

Changes from Revision C (September 2015) to Revision D	Page
• Changed "Typical Application Diagram" to "Simplified Schematic"	1
• Changed the body size	1
• Changed "Device Options" to "Device Comparison Table"	3
• Changed the descriptions for the SRP and SRN pins	3
• Changed Electrical Characteristics: Power-On Reset	5
• Changed all instances of "relaxation mode" to "RELAX mode"	13
• Added "FULLSLEEP mode" to the introduction in Power Modes	19

Changes from Revision B (October 2012) to Revision C	Page
• Changed 32-Ahr to 14,500-mAh	1
• Added <i>ESD Ratings</i> table, <i>Feature Description</i> section, <i>Device Functional Modes</i> , <i>Application and Implementation</i> section, <i>Power Supply Recommendations</i> section, <i>Layout</i> section, <i>Device and Documentation Support</i> section, and <i>Mechanical, Packaging, and Orderable Information</i> section	1

6 Device Comparison Table

PART NUMBER ⁽¹⁾	FIRMWARE VERSION	PACKAGE ⁽²⁾	T _A	COMMUNICATION FORMAT
BQ27545-G1	2.24	CSP-15	–40°C to 85°C	I ² C, HDQ ⁽¹⁾

- (1) bq27545-G1 is shipped in I²C mode.
 (2) For the most current package and ordering information, see the Package Option Addendum at the end of this document, or see the TI website at www.ti.com.

7 Pin Configuration and Functions

YZF Package
15-Pin DSBGA
Top View

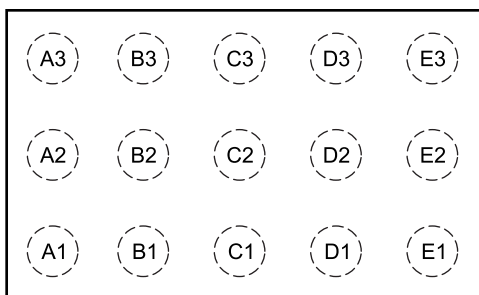

YZF Package
15-Pin DSBGA
Bottom View

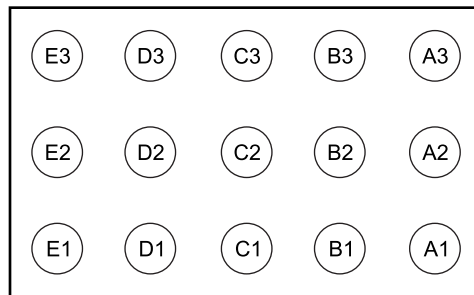

Pin Functions

PIN		TYPE ⁽¹⁾	DESCRIPTION
NAME	NO.		
SRP	A1	IA	Analog input pin connected to the internal coulomb counter where SRP is nearest the V _{SS} connection. Connect to 5-mΩ to 20-mΩ sense resistor.
SRN	B1	IA	Analog input pin connected to the internal coulomb counter where SRN is nearest the PACK– connection. Connect to the 5-mΩ to 20-mΩ sense resistor.
V _{SS}	C1, C2	P	Device ground
SE	C3	O	Shutdown Enable output. Push-pull output.
V _{CC}	D1	P	Regulator output and processor power. Decouple with 1-μF ceramic capacitor to V _{SS} .
REGIN	E1	P	Regulator input. Decouple with 0.1-μF ceramic capacitor to V _{SS} .
HDQ	A2	I/O	HDQ serial communications line (Slave). Open drain.
TS	B2	IA	Pack thermistor voltage sense (use 103AT-type thermistor). ADC input.
CE	D2	I	Chip Enable. Internal LDO is disconnected from REGIN when driven low.
BAT	E2	IA	Cell-voltage measurement input. ADC input. Recommend 4.8-V maximum for conversion accuracy.
SCL	A3	I	Slave I ² C serial communications clock input line for communication with system (Master). Use with 10-kΩ pullup resistor (typical).
SDA	B3	I/O	Slave I ² C serial communications data line for communication with system (Master). Open-drain I/O. Use with 10-kΩ pullup resistor (typical).
NC/GPIO	D3, E3	NC	Do not connect for proper operation; reserved for future GPIO.

- (1) IA = Analog input, I/O = Digital input/output, P = Power connection, NC = No connect

8 Specifications

8.1 Absolute Maximum Ratings

 over operating free-air temperature range (unless otherwise noted)⁽¹⁾

		MIN	MAX	UNIT
V_I	Regulator input, REGIN	-0.3	5.5	V
V_{CC}	Supply voltage	-0.3	2.75	V
V_{IOD}	Open-drain I/O pins (SDA, SCL, HDQ)	-0.3	5.5	V
V_{BAT}	BAT input, (pin E2)	-0.3	5.5	V
V_I	Input voltage range to all others (pins GPIO, SRP, SRN, TS)	-0.3	$V_{CC} + 0.3$	V
T_A	Operating free-air temperature	-40	85	°C
T_F	Functional temperature	-40	100	°C
T_{stg}	Storage temperature	-65	150	°C

- (1) Stresses beyond those listed under *absolute maximum ratings* may cause permanent damage to the device. These are stress ratings only, and functional operation of the device at these or any other conditions beyond those indicated under *recommended operating conditions* is not implied. Exposure to absolute-maximum-rated conditions for extended periods may affect device reliability.

8.2 ESD Ratings

		VALUE	UNIT
$V_{(ESD)}$	Electrostatic discharge	Human-body model (HBM), per ANSI/ESDA/JEDEC JS-001 ⁽¹⁾	BAT pin all pins
			±1500 ±2000
		Charged-device model (CDM), per JEDEC specification JESD22-C101 ⁽²⁾	±500

- (1) JEDEC document JEP155 states that 500-V HBM allows safe manufacturing with a standard ESD control process.
 (2) JEDEC document JEP157 states that 250-V CDM allows safe manufacturing with a standard ESD control process.

8.3 Recommended Operating Conditions

 $T_A = -40^{\circ}\text{C}$ to 85°C ; typical values at $T_A = 25^{\circ}\text{C}$ and $V_{REGIN} = V_{BAT} = 3.6\text{ V}$ (unless otherwise noted)

		MIN	NOM	MAX	UNIT
V_I	Supply voltage, REGIN	No operating restrictions		2.8	4.5
		No FLASH writes		2.45	2.8
C_{REGIN}	External input capacitor for internal LDO between REGIN and V_{SS}	Nominal capacitor values specified. Recommend a 5% ceramic X5R type capacitor located close to the device.		0.1	μF
C_{LDO25}	External output capacitor for internal LDO between V_{CC} and V_{SS}	0.47	1		μF
t_{PUCD}	Power-up communication delay			250	ms

8.4 Thermal Information

THERMAL METRIC ⁽¹⁾		bq27545-G1		UNIT
		YZF (DSBGA)		
		15 PINS		
$R_{\theta JA}$	Junction-to-ambient thermal resistance	70		°C/W
$R_{\theta JC(top)}$	Junction-to-case (top) thermal resistance	17		°C/W
$R_{\theta JB}$	Junction-to-board thermal resistance	20		°C/W
Ψ_{JT}	Junction-to-top characterization parameter	1		°C/W
Ψ_{JB}	Junction-to-board characterization parameter	18		°C/W
$R_{\theta JC(bot)}$	Junction-to-case (bottom) thermal resistance	N/A		°C/W

- (1) For more information about traditional and new thermal metrics, see the Semiconductor and IC Package Thermal Metrics application report, [SPRA953](#).

8.5 Electrical Characteristics: Supply Current

 $T_A = 25^\circ\text{C}$ and $V_{\text{REGIN}} = V_{\text{BAT}} = 3.6\text{ V}$ (unless otherwise noted)

PARAMETER	TEST CONDITIONS	MIN	TYP	MAX	UNIT
I_{CC}	Normal operating mode current ⁽¹⁾ Fuel gauge in NORMAL mode $I_{\text{LOAD}} > \text{Sleep Current}$		118		μA
$I_{\text{(SLP)}}$	Low-power operating mode current ⁽¹⁾ Fuel gauge in SLEEP mode $I_{\text{LOAD}} < \text{Sleep Current}$		62		μA
$I_{\text{(FULLSLP)}}$	Low-power operating mode current ⁽¹⁾ Fuel gauge in FULLSLEEP mode $I_{\text{LOAD}} < \text{Sleep Current}$		23		μA
$I_{\text{(HIB)}}$	HIBERNATE operating mode current ⁽¹⁾ Fuel gauge in HIBERNATE mode $I_{\text{LOAD}} < \text{Hibernate Current}$		8		μA

(1) Specified by design. Not tested in production.

8.6 Electrical Characteristics: Digital Input and Output DC

 $T_A = -40^\circ\text{C}$ to 85°C ; typical values at $T_A = 25^\circ\text{C}$ and $V_{\text{REGIN}} = V_{\text{BAT}} = 3.6\text{ V}$ (unless otherwise noted)

PARAMETER	TEST CONDITIONS	MIN	TYP	MAX	UNIT
V_{OL}	Output voltage low (HDQ, SDA, SCL, SE) $I_{\text{OL}} = 3\text{ mA}$			0.4	V
$V_{\text{OH(PP)}}$	Output high voltage (SE) $I_{\text{OH}} = -1\text{ mA}$	$V_{\text{CC}} - 0.5$			V
$V_{\text{OH(OD)}}$	Output high voltage (HDQ, SDA, SCL) External pullup resistor connected to V_{CC}	$V_{\text{CC}} - 0.5$			V
V_{IL}	Input voltage low (HDQ, SDA, SCL)	-0.3		0.6	V
V_{IH}	Input voltage high (HDQ, SDA, SCL)	1.2		5.5	V
$V_{\text{IL(CE)}}$	CE Low-level input voltage	$V_{\text{REGIN}} = 2.8\text{ V}$ to 4.5 V	2.65	0.8	V
$V_{\text{IH(CE)}}$	CE High-level input voltage		$V_{\text{REGIN}} - 0.5$	0.8	
I_{IKG}	Input leakage current (I/O pins)			0.3	μA

8.7 Electrical Characteristics: Power-On Reset

 $T_A = -40^\circ\text{C}$ to 85°C , $C_{\text{(REG)}} = 0.47\text{ }\mu\text{F}$, $2.45\text{ V} < V_{\text{(REGIN)}} = V_{\text{BAT}} < 5.5\text{ V}$; typical values at $T_A = 25^\circ\text{C}$ and $V_{\text{(REGIN)}} = V_{\text{BAT}} = 3.6\text{ V}$ (unless otherwise noted)

PARAMETER	TEST CONDITIONS	MIN	TYP	MAX	UNIT
$V_{\text{IT+}}$	Positive-going battery voltage input at V_{CC}	2.05	2.15	2.2	V
V_{HYS}	Power-on reset hysteresis		115		mV

8.8 Electrical Characteristics: 2.5-V LDO Regulator

 $T_A = -40^\circ\text{C}$ to 85°C , $C_{\text{(REG)}} = 0.47\text{ }\mu\text{F}$, $2.45\text{ V} < V_{\text{(REGIN)}} = V_{\text{BAT}} < 5.5\text{ V}$; typical values at $T_A = 25^\circ\text{C}$ and $V_{\text{(REGIN)}} = V_{\text{BAT}} = 3.6\text{ V}$ (unless otherwise noted)

PARAMETER	TEST CONDITION	MIN	TYP	MAX	UNIT
V_{CC}	$2.8\text{ V} \leq V_{\text{(REGIN)}} \leq 4.5\text{ V}$, $I_{\text{OUT}} \leq 16\text{ mA}$	2.3	2.5	2.6	V
	$2.45\text{ V} \leq V_{\text{(REGIN)}} < 2.8\text{ V}$ (low battery), $I_{\text{OUT}} \leq 3\text{ mA}$	2.3			V

8.9 Electrical Characteristics: Internal Clock Oscillators

 $T_A = -40^\circ\text{C}$ to 85°C , $2.4\text{ V} < V_{CC} < 2.6\text{ V}$; typical values at $T_A = 25^\circ\text{C}$ and $V_{CC} = 2.5\text{ V}$ (unless otherwise noted)

PARAMETER		TEST CONDITIONS	MIN	TYP	MAX	UNIT
$f_{(\text{OSC})}$	Operating frequency			2.097		MHz
$f_{(\text{LOSC})}$	Operating frequency			32.768		kHz

8.10 Electrical Characteristics: Integrating ADC (Coulomb Counter) Characteristics

 $T_A = -40^\circ\text{C}$ to 85°C , $C_{(\text{REG})} = 0.47\text{ }\mu\text{F}$, $2.45\text{ V} < V_{(\text{REGIN})} = V_{\text{BAT}} < 5.5\text{ V}$; typical values at $T_A = 25^\circ\text{C}$ and $V_{(\text{REGIN})} = V_{\text{BAT}} = 3.6\text{ V}$ (unless otherwise noted)

PARAMETER		TEST CONDITIONS	MIN	TYP	MAX	UNIT
V_{SR}	Input voltage range, $V_{(\text{SRN})}$ and $V_{(\text{SRP})}$	$V_{\text{SR}} = V_{(\text{SRN})} - V_{(\text{SRP})}$	-0.125		0.125	V
$t_{\text{CONV}(\text{SR})}$	Conversion time	Single conversion		1		s
	Resolution		14		15	bits
$V_{\text{OS}(\text{SR})}$	Input offset			10		μV
INL	Integral nonlinearity error			± 0.007	± 0.034	FSR
$Z_{\text{IN}(\text{SR})}$	Effective input resistance ⁽¹⁾		2.5			M Ω
$I_{\text{lk}(\text{SR})}$	Input leakage current ⁽¹⁾				0.3	μA

(1) Specified by design. Not production tested.

8.11 Electrical Characteristics: ADC (Temperature and Cell Voltage)

 $T_A = -40^\circ\text{C}$ to 85°C , $C_{(\text{REG})} = 0.47\text{ }\mu\text{F}$, $2.45\text{ V} < V_{(\text{REGIN})} = V_{\text{BAT}} < 5.5\text{ V}$; typical values at $T_A = 25^\circ\text{C}$ and $V_{(\text{REGIN})} = V_{\text{BAT}} = 3.6\text{ V}$ (unless otherwise noted)

PARAMETER		TEST CONDITIONS	MIN	TYP	MAX	UNIT
$V_{\text{IN}(\text{TS})}$	Input voltage range (TS)		$V_{\text{SS}} - 0.125$		V_{CC}	V
$V_{\text{IN}(\text{BAT})}$	Input voltage range (BAT)		$V_{\text{SS}} - 0.125$		5	V
$V_{\text{IN}(\text{ADC})}$	Input voltage range to ADC		0.05		1	V
$G_{(\text{TEMP})}$	Temperature sensor voltage gain			-2		mV/ $^\circ\text{C}$
$t_{\text{CONV}(\text{ADC})}$	Conversion time				125	ms
	Resolution		14		15	bits
$V_{\text{OS}(\text{ADC})}$	Input offset			1		mV
$Z_{(\text{TS})}$	Effective input resistance (TS) ⁽¹⁾	bq27545-G1 not measuring external temperature	8			M Ω
$Z_{(\text{BAT})}$	Effective input resistance (BAT) ⁽¹⁾	bq27545-G1 not measuring cell voltage	8			M Ω
		bq27545-G1 measuring cell voltage		100		k Ω
$I_{\text{lk}(\text{ADC})}$	Input leakage current				0.3	μA

(1) Specified by design. Not production tested.

8.12 Electrical Characteristics: Data Flash Memory

 $T_A = -40^\circ\text{C}$ to 85°C , $C_{(\text{REG})} = 0.47\text{ }\mu\text{F}$, $2.45\text{ V} < V_{(\text{REGIN})} = V_{\text{BAT}} < 5.5\text{ V}$; typical values at $T_A = 25^\circ\text{C}$ and $V_{(\text{REGIN})} = V_{\text{BAT}} = 3.6\text{ V}$ (unless otherwise noted)

PARAMETER		TEST CONDITIONS	MIN	TYP	MAX	UNIT
t_{DR}	Data retention ⁽¹⁾		10			Years
	Flash programming write-cycles ⁽¹⁾		20,000			Cycles
t_{WORDPROG}	Word programming time ⁽¹⁾				2	ms
I_{CCPROG}	Flash-write supply current ⁽¹⁾			5	10	mA
t_{DFERASE}	Data flash master erase time ⁽¹⁾		200			ms
t_{PGERASE}	Flash page erase time ⁽¹⁾		20			ms

(1) Specified by design. Not production tested.

8.13 HDQ Communication Timing Characteristics

$T_A = -40^{\circ}\text{C}$ to 85°C , $C_{\text{REG}} = 0.47\ \mu\text{F}$, $2.45\ \text{V} < V_{\text{REGIN}} = V_{\text{BAT}} < 5.5\ \text{V}$; typical values at $T_A = 25^{\circ}\text{C}$ and $V_{\text{REGIN}} = V_{\text{BAT}} = 3.6\ \text{V}$ (unless otherwise noted)

PARAMETER		TEST CONDITIONS	MIN	NOM	MAX	UNIT
$t_{\text{(CYCH)}}$	Cycle time, host to bq27545-G1		190			μs
$t_{\text{(CYCD)}}$	Cycle time, bq27545-G1 to host		190	205	250	μs
$t_{\text{(HW1)}}$	Host sends 1 to bq27545-G1		0.5		50	μs
$t_{\text{(DW1)}}$	bq27545-G1 sends 1 to host		32		50	μs
$t_{\text{(HW0)}}$	Host sends 0 to bq27545-G1		86		145	μs
$t_{\text{(DW0)}}$	bq27545-G1 sends 0 to host		80		145	μs
$t_{\text{(RSPS)}}$	Response time, bq27545-G1 to host		190		950	μs
$t_{\text{(B)}}$	Break time		190			μs
$t_{\text{(BR)}}$	Break recovery time		40			μs
$t_{\text{(RISE)}}$	HDQ line rising time to logic 1 (1.2 V)				950	ns

8.14 I²C-Compatible Interface Timing Characteristics

$T_A = -40^{\circ}\text{C}$ to 85°C , $C_{\text{REG}} = 0.47\ \mu\text{F}$, $2.45\ \text{V} < V_{\text{REGIN}} = V_{\text{BAT}} < 5.5\ \text{V}$; typical values at $T_A = 25^{\circ}\text{C}$ and $V_{\text{REGIN}} = V_{\text{BAT}} = 3.6\ \text{V}$ (unless otherwise noted)

PARAMETER		TEST CONDITIONS	MIN	NOM	MAX	UNIT
t_r	SCL/SDA rise time				300	ns
t_f	SCL/SDA fall time				300	ns
$t_{w(H)}$	SCL pulse width (high)		600			ns
$t_{w(L)}$	SCL pulse width (low)		1.3			μs
$t_{\text{su(STA)}}$	Setup for repeated start		600			ns
$t_{d(\text{STA})}$	Start to first falling edge of SCL		600			ns
$t_{\text{su(DAT)}}$	Data setup time		1000			ns
$t_{h(\text{DAT})}$	Data hold time		0			ns
$t_{\text{su(STOP)}}$	Setup time for stop		600			ns
t_{BUF}	Bus free time between stop and start		66			μs
f_{SCL}	Clock frequency ⁽¹⁾				400	kHz

(1) If the clock frequency (f_{SCL}) is $> 100\ \text{kHz}$, use 1-byte write commands for proper operation. All other transactions types are supported at 400 kHz. (Refer to [I²C Interface](#).)

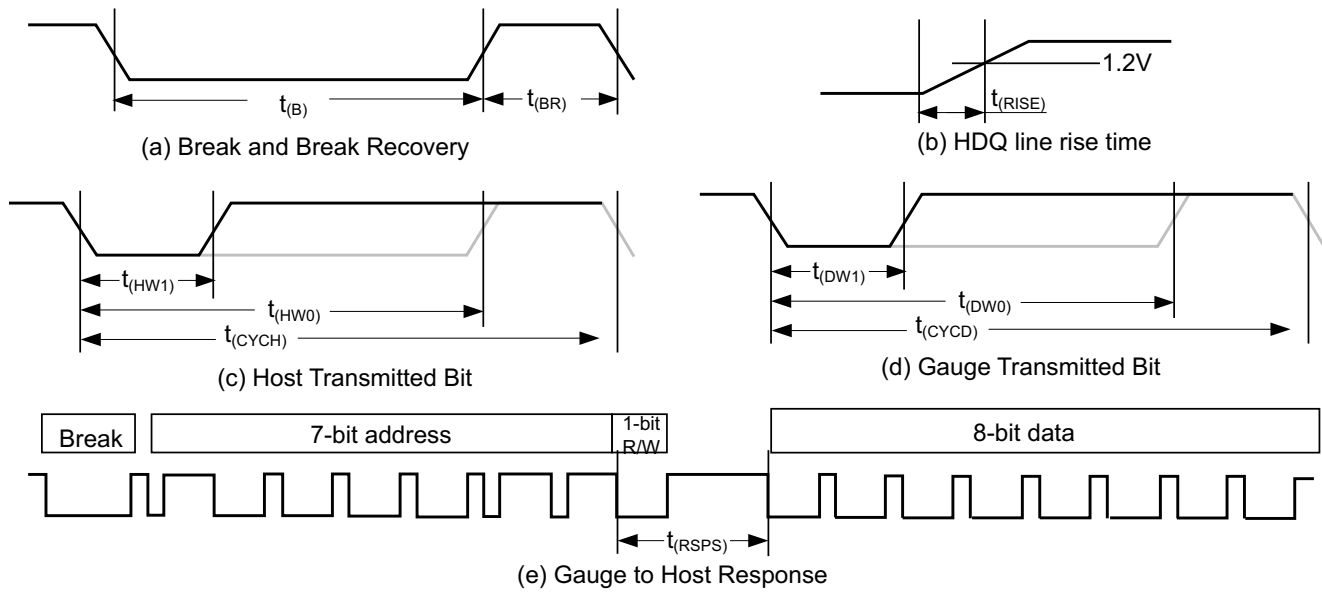

Figure 1. HDQ Timing Diagrams

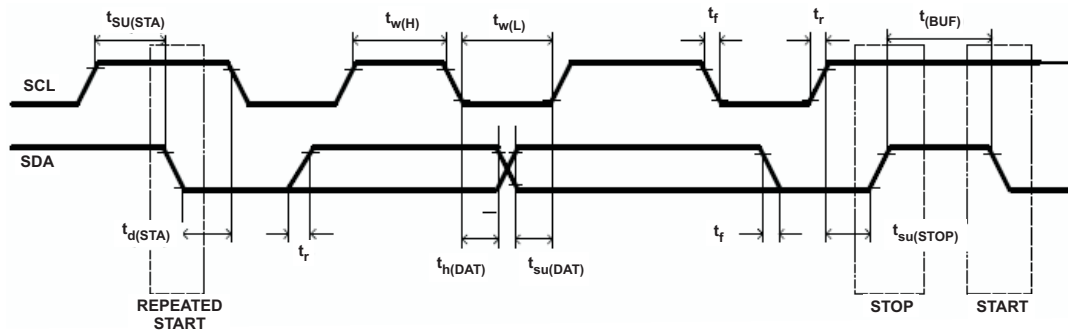

Figure 2. I²C-Compatible Interface Timing Diagrams

8.15 Typical Characteristics

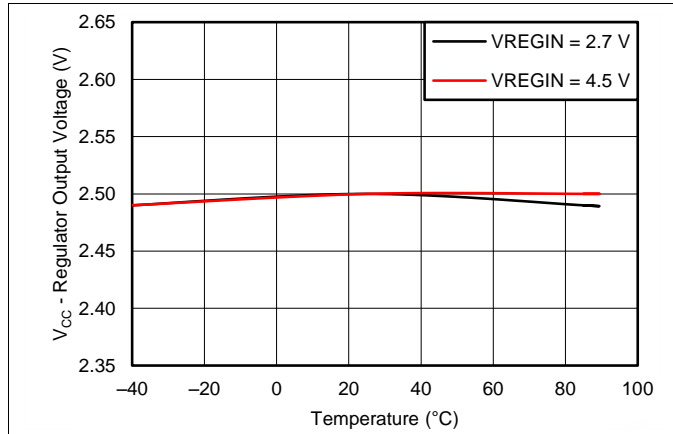

Figure 3. Regulator Output Voltage Vs. Temperature

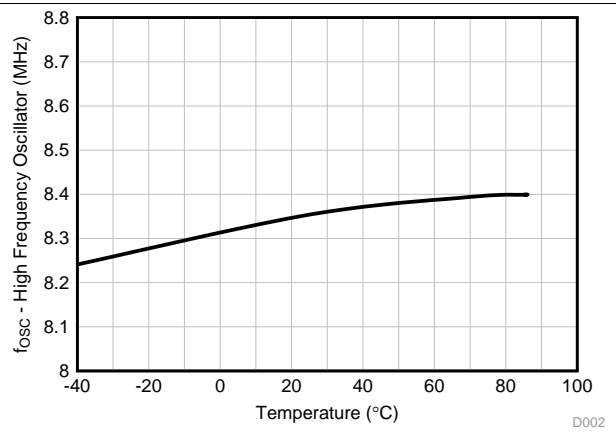

Figure 4. High-Frequency Oscillator Frequency Vs. Temperature

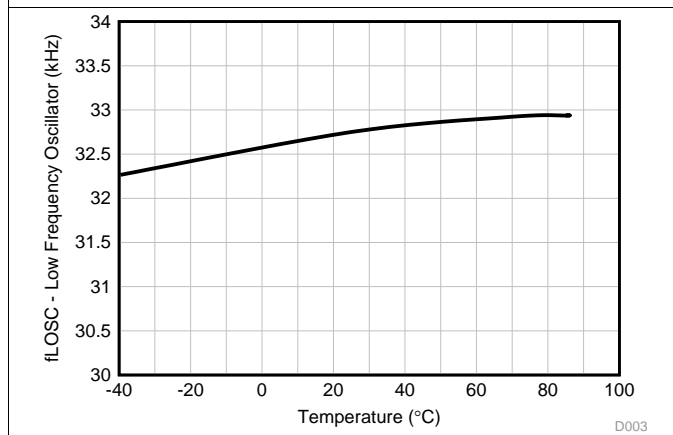

Figure 5. Low-Frequency Oscillator Frequency Vs. Temperature

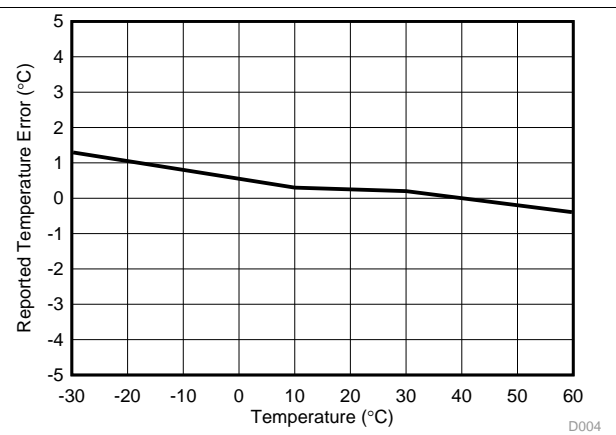

Figure 6. Reported Internal Temperature Measurement Vs. Temperature

9 Detailed Description

9.1 Overview

The bq27545-G1 accurately predicts the battery capacity and other operational characteristics of a single Li-based rechargeable cell. It can be interrogated by a system processor to provide cell information, such as state-of-charge (SOC) and time-to-empty (TTE).

Information is accessed through a series of commands, called Standard Commands. Further capabilities are provided by the additional Extended Commands set. Both sets of commands, indicated by the general format *Command()*, are used to read and write information in the bq27545-G1 control and status registers, as well as its data flash locations. Commands are sent from the system to the gauge using the bq27545-G1 serial communications engine, and can be executed during application development, pack manufacture, or end-equipment operation.

Cell information is stored in the bq27545-G1 in non-volatile flash memory. Many of these data flash locations are accessible during application development. They cannot, generally, be accessed directly during end-equipment operation. To access to these locations, use the bq27546-G1 companion evaluation software, individual commands, or a sequence of data-flash-access commands. To access a desired data flash location, the correct data flash Subclass and offset must be known.

The bq27545-G1 provides 64 bytes of user-programmable data flash memory, partitioned into two (2) 32-byte blocks: **Manufacturer Info Block A** and **Manufacturer Info Block B**. This data space is accessed through a data flash interface. For specific details on accessing the data flash, see [Manufacturer Information Blocks](#). The key to the bq27545-G1 high-accuracy gas gauging prediction is Texas Instrument's proprietary Impedance Track algorithm. This algorithm uses cell measurements, characteristics, and properties to create state-of-charge predictions that can achieve less than 1% error across a wide variety of operating conditions and over the lifetime of the battery.

The bq27545-G1 measures charge/discharge activity by monitoring the voltage across a small-value series sense resistor (5 mΩ to 20 mΩ typical) located between the CELL– and the battery's PACK– terminal. When a cell is attached to the bq27545-G1, cell impedance is learned based on cell current, cell open-circuit voltage (OCV), and cell voltage under loading conditions.

The bq27545-G1 external temperature sensing is optimized with the use of a high accuracy negative temperature coefficient (NTC) thermistor with $R_{25} = 10 \text{ k}\Omega \pm 1\%$ and $B_{25/85} = 3435 \text{ K} \pm 1\%$ (such as Semitec 103AT) for measurement. The bq27545-G1 can also be configured to use its internal temperature sensor. The bq27545-G1 uses temperature to monitor the battery-pack environment, which is used for fuel gauging and cell protection functionality.

To minimize power consumption, the bq27545-G1 has different power modes: NORMAL, SLEEP, FULLSLEEP, and HIBERNATE. The bq27545-G1 passes automatically between these modes, depending upon the occurrence of specific events, though a system processor can initiate some of these modes directly. [Power Modes](#) has more details.

NOTE

FORMATTING CONVENTIONS IN THIS DOCUMENT:

Commands: *italics* with *parentheses()* and no breaking spaces. e.g., *RemainingCapacity()*

Data Flash: *italics*, **bold**, and *breaking spaces*. e.g., **Design Capacity**

Register bits and flags: *italics* with brackets[]. e.g., *[TDA]*

Data flash bits: *italics*, **bold**, and brackets[]. e.g., **[LED1]**

Modes and states: ALL CAPITALS. e.g., UNSEALED mode

9.2 Functional Block Diagram

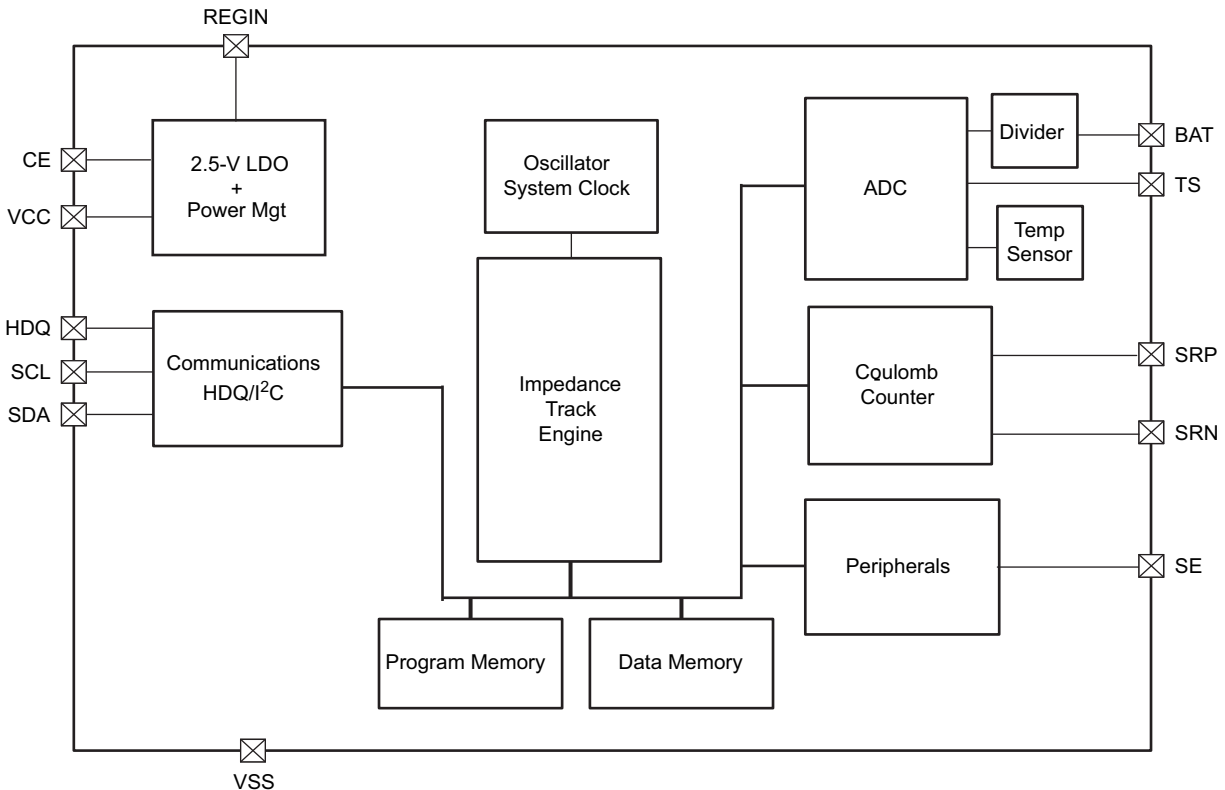

9.3 Feature Description

9.3.1 Fuel Gauging

The bq27545-G1 measures the cell voltage, temperature, and current to determine battery SOC based on Impedance Track algorithm (see the *Theory and Implementation of Impedance Track Battery Fuel-Gauging Algorithm Application Report [SLUA450]* for more information). The bq27545-G1 monitors charge and discharge activity by sensing the voltage across a small-value resistor (5 mΩ to 20 mΩ typical) between the SRP and SRN pins and in series with the cell. By integrating charge passing through the battery, the battery's SOC is adjusted during battery charge or discharge.

The total battery capacity is found by comparing states of charge before and after applying the load with the amount of charge passed. When an application load is applied, the impedance of the cell is measured by comparing the OCV obtained from a predefined function for present SOC with the measured voltage under load. Measurements of OCV and charge integration determine chemical state of charge and chemical capacity (Qmax). The initial Qmax values are taken from a cell manufacturers' data sheet multiplied by the number of parallel cells. It is also used for the value in **Design Capacity**. The bq27545-G1 acquires and updates the battery-impedance profile during normal battery usage. It uses this profile, along with SOC and the Qmax value, to determine *FullChargeCapacity()* and *StateOfCharge()*, specifically for the present load and temperature. *FullChargeCapacity()* is reported as capacity available from a fully charged battery under the present load and temperature until *Voltage()* reaches the **Terminate Voltage**. *NominalAvailableCapacity()* and *FullAvailableCapacity()* are the uncompensated (no or light load) versions of *RemainingCapacity()* and *FullChargeCapacity()* respectively.

The bq27545-G1 has two flags accessed by the *Flags()* function that warns when the battery's SOC has fallen to critical levels. When *RemainingCapacity()* falls below the first capacity threshold, specified in **SOC1 Set Threshold**, the [SOC1] (*State of Charge Initial*) flag is set. The flag is cleared once *RemainingCapacity()* rises above **SOC1 Clear Threshold**. All units are in mAh.

Feature Description (continued)

When *RemainingCapacity()* falls below the second capacity threshold, **SOCF Set Threshold**, the *[SOCF]* (*State of Charge Final*) flag is set, serving as a final discharge warning. If **SOCF Set Threshold** = -1, the flag is inoperative during discharge. Similarly, when *RemainingCapacity()* rises above **SOCF Clear Threshold** and the *[SOCF]* flag has already been set, the *[SOCF]* flag is cleared. All units are in mAh.

The bq27545-G1 has two additional flags accessed by the *Flags()* function that warns of internal battery conditions. The fuel gauge monitors the cell voltage during relaxed conditions to determine if an internal short has been detected. When this condition occurs, *[ISD]* will be set. The bq27545-G1 also has the capability of detecting when a tab has been disconnected in a 2-cell parallel system by actively monitoring the *SOH*. When this condition occurs, *[TDD]* will be set.

9.3.2 Impedance Track Variables

The bq27545-G1 has several data flash variables that permit the user to customize the Impedance Track algorithm for optimized performance. These variables are dependent upon the power characteristics of the application as well as the cell itself.

9.3.2.1 Load Mode

Load Mode is used to select either the constant-current or constant-power model for the Impedance Track algorithm as used in **Load Select** (see [Load Select](#)). When **Load Mode** is 0, the *Constant Current Model* is used (default). When **Load Mode** is 1, the *Constant Power Model* is used. The *[LDMD]* bit of *CONTROL_STATUS* reflects the status of **Load Mode**.

9.3.2.2 Load Select

Load Select defines the type of power or current model to be used to compute load-compensated capacity in the Impedance Track algorithm. If **Load Mode** = 0 (*Constant Current*), then the options presented in [Table 1](#) are available.

Table 1. Constant-Current Model Used When Load Mode = 0

Load Select Value	CURRENT MODEL USED
0	Average discharge current from previous cycle: There is an internal register that records the average discharge current through each entire discharge cycle. The previous average is stored in this register.
1 (default)	Present average discharge current: This is the average discharge current from the beginning of this discharge cycle until present time.
2	Average current: based off the <i>AverageCurrent()</i>
3	Current: based off of a low-pass-filtered version of <i>AverageCurrent()</i> ($\tau = 14$ s)
4	Design capacity/5: C Rate based off of Design Capacity /5 or a C/5 rate in mA.
5	Use the value specified by <i>AtRate()</i>
6	Use the value in User_Rate-mA : This gives a completely user-configurable method.

If **Load Mode** = 1 (*Constant Power*) then the following options are available:

Table 2. Constant-Power Model Used When Load Mode = 1

Load Select Value	POWER MODEL USED
0	Average discharge power from previous cycle: There is an internal register that records the average discharge power through each entire discharge cycle. The previous average is stored in this register.
1	Present average discharge power: This is the average discharge power from the beginning of this discharge cycle until present time.
2	Average current x voltage: based off the <i>AverageCurrent()</i> and <i>Voltage()</i> .
3	Current x voltage: based off of a low-pass-filtered version of <i>AverageCurrent()</i> ($\tau = 14$ s) and <i>Voltage()</i>
4	Design energy/5: C Rate based off of Design Energy /5 or a C/5 rate in mA.
5	Use the value specified by <i>AtRate()</i>
6	Use the value in User_Rate-Pwr . This gives a completely user-configurable method.

9.3.2.3 Reserve Cap-mAh

Reserve Cap-mAh determines how much actual remaining capacity exists after reaching 0 *RemainingCapacity()*, before **Terminate Voltage** is reached when **Load Mode** = 0 is selected. A loaded rate or no-load rate of compensation can be selected for *Reserve Cap* by setting the [RESCAP] bit in *Pack Configuration* data flash register.

9.3.2.4 Reserve Energy

Reserve Energy determines how much actual remaining capacity exists after reaching 0 *RemainingCapacity()* which is equivalent to 0 remaining power, before **Terminate Voltage** is reached when **Load Mode** = 1 is selected. A loaded rate or no-load rate of compensation can be selected for *Reserve Cap* by setting the [RESCAP] bit in *Pack Configuration* data flash register..

9.3.2.5 Design Energy Scale

Design Energy Scale is used to select the scale/unit of a set of data flash parameters. The value of **Design Energy Scale** can be either 1 or 10 only, other values are not supported. For battery capacities larger than 6 AHr, **Design Energy Scale** = 10 is recommended.

Table 3. Data Flash Parameter Scale/Unit Based On Design Energy Scale

DATA FLASH	DESIGN ENERGY SCALE = 1 (default)	DESIGN ENERGY SCALE = 10
<i>Design Energy</i>	mWh	cWh
<i>Reserve Energy</i>	mWh	cWh
<i>Avg Power Last Run</i>	mW	cW
<i>User Rate-Pwr</i>	mWh	cWh
<i>T Rise</i>	No Scale	Scaled by x10

9.3.2.6 Dsg Current Threshold

This register is used as a threshold by many functions in the bq27545-G1 to determine if actual discharge current is flowing into or out of the cell. The default for this register should be sufficient for most applications. This threshold should be set low enough to be below any normal application load current but high enough to prevent noise or drift from affecting the measurement.

9.3.2.7 Chg Current Threshold

This register is used as a threshold by many functions in the bq27545-G1 to determine if actual charge current is flowing into or out of the cell. The default for this register should be sufficient for most applications. This threshold should be set low enough to be below any normal charge current but high enough to prevent noise or drift from affecting the measurement.

9.3.2.8 Quit Current, Dsg Relax Time, Chg Relax Time, and Quit Relax Time

The **Quit Current** is used as part of the Impedance Track algorithm to determine when the bq27545-G1 enters RELAX mode from a current flowing mode in either the charge direction or the discharge direction. The value of Quit Current is set to a default value that should be above the standby current of the system.

Either of the following criteria must be met to enter RELAX mode:

1. $|AverageCurrent()| < |Quit Current|$ for **Dsg Relax Time**.
2. $|AverageCurrent()| < |Quit Current|$ for **Chg Relax Time**.

After about 6 minutes in RELAX mode, the bq27545-G1 attempts to take accurate OCV readings. An additional requirement of $dV/dt < 1 \mu V/s$ is required for the bq27545-G1 to perform Qmax updates. These updates are used in the Impedance Track algorithms. It is critical that the battery voltage be relaxed during OCV readings and that the current is not higher than C/20 when attempting to go into RELAX mode.

Quit Relax Time specifies the minimum time required for *AverageCurrent()* to remain above the **QuitCurrent** threshold before exiting RELAX mode.

9.3.2.9 Qmax

Qmax contains the maximum chemical capacity of the active cell profiles, and is determined by comparing states of charge before and after applying the load with the amount of charge passed. They also correspond to capacity at low rate of discharge, such as C/20 rate. For high accuracy, this value is periodically updated by the bq27545-G1 during operation. Based on the battery cell capacity information, the initial value of chemical capacity should be entered in **Qmax** field. The Impedance Track algorithm will update this value and maintain it in the **Pack** profile.

9.3.2.10 Update Status

The **Update Status** register indicates the status of the Impedance Track algorithm.

Table 4. Update Status Definitions

UPDATE STATUS	STATUS
0x02	Qmax and Ra data are learned, but Impedance Track is not enabled. This should be the standard setting for a golden image.
0x04	Impedance Track is enabled but Qmax and Ra data are not learned.
0x05	Impedance Track is enabled and only Qmax has been updated during a learning cycle.
0x06	Impedance Track is enabled. Qmax and Ra data are learned after a successful learning cycle. This should be the operation setting for end equipment.

This register should only be updated by the bq27545-G1 during a learning cycle or when *IT_ENABLE* subcommand is received. Refer to the *How to Generate Golden Image for Single-Cell Impedance Track Device Application Note (SLUA544)* for learning cycle details.

9.3.2.11 Avg I Last Run

The bq27545-G1 logs the current averaged from the beginning to the end of each discharge cycle. It stores this average current from the previous discharge cycle in this register. This register should never be modified. It is only updated by the bq27545-G1 when required.

9.3.2.12 Avg P Last Run

The bq27545-G1 logs the power averaged from the beginning to the end of each discharge cycle. It stores this average power from the previous discharge cycle in this register. To get a correct average power reading the bq27545-G1 continuously multiplies instantaneous current times *Voltage()* to get power. It then logs this data to derive the average power. This register should never require modification. It is only updated by the bq27545-G1 when required.

9.3.2.13 Delta Voltage

The bq27545-G1 stores the maximum difference of *Voltage()* during short load spikes and normal load, so the Impedance Track algorithm can calculate remaining capacity for pulsed loads. It is not recommended to change this value.

9.3.2.14 Ra Tables and Ra Filtering Related Parameters

These tables contain encoded data and are automatically updated during device operation. The bq27545-G1 has a filtering process to eliminate unexpected fluctuations in Ra values while the Ra values are being updated. The DF parameters **RaFilter**, **RaMaxDelta**, **MaxResfactor**, and **MinResfactor** control the Filtering process of Ra values. **RaMaxDelta** Limits the change in Ra values to an absolute magnitude. **MinResFactor** and **MaxResFactor** parameters are cumulative filters which limit the change in Ra values to a scale on a per discharge cycle basis. These values are data flash configurable. No further user changes should be made to Ra values except for reading/writing the values from a pre-learned pack (part of the process for creating golden image files).

9.3.2.15 MaxScaleBackGrid

MaxScaleBackGrid parameter limits the resistance grid point after which back scaling will not be performed. This variable ensures that the resistance values in the lower resistance grid points remain accurate while the battery is at a higher DoD state.

9.3.2.16 Max DeltaV, Min DeltaV

Maximal/Minimal value allowed for delta V, which will be subtracted from simulated voltage during remaining capacity simulation.

9.3.2.17 Qmax Max Delta %

Maximal change of Qmax during one update, as percentage of *Design Capacity*. If the gauges attempts to change Qmax exceeds this limit, changed value will be capped to old value \pm DesignCapacity \times QmaxMaxDelta/100.

9.3.2.18 Fast Resistance Scaling

When Fast Resistance Scaling is enabled by setting the *[FConvEn]* bit in *Pack Configuration B*, the algorithm improves accuracy at the end of discharge. The *RemainingCapacity()* and *StateOfCharge()* should smoothly converge to 0. The algorithm starts convergence improvements when cell voltage goes below (**Terminate Voltage + Term V Delta**) or *StateofCharge()* goes below **Fast Scale Start SOC**. For most applications, the default value of **Term V Delta** and **Fast Scale Start SOC** are recommended. Also TI recommends keeping (**Terminate Voltage + Term V Delta**) below 3.6 V for most battery applications.

9.3.2.19 StateOfCharge() Smoothing

When operating conditions change (such as temperature, discharge current, and resistance, for example), it can lead to large changes of compensated battery capacity and battery capacity remaining. These changes can result in large changes of *StateOfCharge()*. When *[SmoothEn]* is enabled in **Pack Configuration C**, the smoothing algorithm injects gradual changes of battery capacity when conditions vary. This results in a gradual change of *StateOfCharge()* and can provide a better end-user experience for *StateOfCharge()* reporting.

The *RemainingCapacity()*, *FullChargeCapacity()*, and *StateOfCharge()* are modified depending on *[SmoothEn]* as below.

<i>[SmoothEn]</i>	<i>RemainingCapacity()</i>	<i>FullChargeCapacity()</i>	<i>StateOfCharge()</i>
0	<i>UnfilteredRM()</i>	<i>UnfilteredFCC()</i>	<i>UnfilteredRM()/UnfilteredFCC()</i>
1	<i>FilteredRM()</i>	<i>FilteredFCC()</i>	<i>FilteredRM()/FilteredFCC()</i>

9.3.2.20 DeltaV Max Delta

Maximal change of Delta V value. If attempted change of the value exceeds this limit, change value will be capped to old value \pm DeltaV Max Delta.

9.3.2.21 Lifetime Data Logging Parameters

The Lifetime Data logging function helps development and diagnosis with the bq27545-G1. *IT_ENABLE* must be enabled (Command 0x0021) for lifetime data logging functions to be active. bq27545-G1 logs the lifetime data as specified in the **Lifetime Data** and **Lifetime Temp Samples** data Flash Subclasses. The data log recordings are controlled by the **Lifetime Resolution** data flash subclass.

The Lifetime Data Logging can be started by setting the *IT_ENABLE* bit and setting the Update Time register to a non-zero value.

Once the Lifetime Data Logging function is enabled, the measured values are compared to what is already stored in the data flash. If the measured value is higher than the maximum or lower than the minimum value stored in the data flash by more than the *Resolution* set for at least one parameter, the entire Data Flash Lifetime Registers are updated after at least *LTUpdateTime*.

LTUpdateTime sets the minimum update time between DF writes. When a new maximum or minimum is detected, a LT Update window of [update time] second is enabled and the DF writes occur at the end of this window. Any additional max/min value detected within this window will also be updated. The first new maximum or minimum value detected after this window will trigger the next LT Update window.

Internal to bq27545-G1, there exists a RAM maximum or minimum table in addition to the DF maximum or minimum table. The RAM table is updated independent of the resolution parameters. The DF table is updated only if at least one of the RAM parameters exceeds the DF value by more than resolution associated with it. When DF is updated, the entire RAM table is written to DF. Consequently, it is possible to see a new maximum or minimum value for a certain parameter even if the value of this parameter never exceeds the maximum or minimum value stored in the data flash for this parameter value by the resolution amount.

The Life Time Data Logging of one or more parameters can be reset or restarted by writing new default (or starting) values to the corresponding data flash registers through sealed or unsealed access as described below. However, when using unsealed access, new values will only take effect after device reset

The logged data can be accessed as R/W in UNSEALED mode from Lifetime Data Subclass (Subclass ID = 59) of data flash. Lifetime data may be accessed (R/W) when sealed using a process identical Manufacturer Info Block B. The DataFlashBlock command code is 4. Note only the first 32 bytes of lifetime data (not resolution parameters) can be R/W when sealed. See [Manufacturer Information Blocks](#) for sealed access. The logging settings such as Temperature Resolution, Voltage Resolution, Current Resolution, and Update Time can be configured only in UNSEALED mode by writing to the Lifetime Resolution Subclass (SubclassID = 66) of the data flash.

The Lifetime resolution registers contain the parameters that set the limits related to how much a data parameter must exceed the previously logged maximum or minimum value to be updated in the lifetime log. For example, V must exceed MaxV by more than Voltage Resolution to update MaxV in the data flash.

9.4 Device Functional Modes

9.4.1 System Control Function

The bq27545-G1 provides system control functions which allows the fuel gauge to enter SHUTDOWN mode to power-off with the assistance of external circuit or provides interrupt function to the system. [Table 5](#) shows the configurations for SE and HDQ pins.

Table 5. SE and HDQ Pin Function

<i>[INTSEL]</i>	COMMUNICATION MODE	SE PIN FUNCTION	HDQ PIN FUNCTION
0 (default)	I ² C	INTERRUPT Mode ⁽¹⁾	Not Used
	HDQ		HDQ Mode ⁽²⁾
1	I ² C	SHUTDOWN Mode	INTERRUPT mode
	HDQ		HDQ Mode ⁽²⁾

(1) [SE_EN] bit in **Pack Configuration** can be enabled to use [SE] and [SHUTDOWN] bits in *CONTROL_STATUS()* function. The SE pin shutdown function is disabled.

(2) HDQ pin is used for communication and HDQ Host Interrupt Feature is available.

9.4.1.1 SHUTDOWN Mode

In the SHUTDOWN mode, the SE pin is used to signal external circuit to power-off the fuel gauge. This feature is useful to shutdown the fuel gauge in a deeply discharged battery to protect the battery. By default, the SHUTDOWN mode is in normal state. By sending the SET_SHUTDOWN subcommand or setting the [SE_EN] bit in **Pack Configuration** register, the [SHUTDOWN] bit is set and enables the shutdown feature. When this feature is enabled and [INTSEL] is set, the SE pin can be in normal state or SHUTDOWN state. The SHUTDOWN state can be entered in HIBERNATE mode (ONLY if HIBERNATE mode is enabled due to low cell voltage), all other power modes will default SE pin to NORMAL state. [Table 6](#) shows the SE pin state in NORMAL or SHUTDOWN mode. The CLEAR_SHUTDOWN subcommand or clearing [SE_EN] bit in the **Pack Configuration** register can be used to disable SHUTDOWN mode.

The bq27545 SE pin will be high impedance at power on reset (POR), the [SE_POL] does not affect the state of SE pin at POR. Also [SE_PU] configuration changes will only take effect after POR. In addition, the [INTSEL] only controls the behavior of the SE pin; it does not affect the function of [SE] and [SHUTDOWN] bits.

Table 6. SE Pin State

		SHUTDOWN Mode [INTSEL] = 1 and ([SE_EN] or [SHUTDOWN] = 1)	
[SE_PU]	[SE_POL]	NORMAL state	SHUTDOWN state
0	0	High Impedance	0
0	1	0	High Impedance
1	0	1	0
1	1	0	1

9.4.1.2 INTERRUPT Mode

By utilizing the INTERRUPT mode, the system can be interrupted based on detected fault conditions as specified in Table 9. The SE or HDQ pin can be selected as the interrupt pin by configuring the [INTSEL] bit based on . In addition, the pin polarity and pullup (SE pin only) can be configured according to the system needs as described in Table 7 or Table 8.

Table 7. SE Pin in INTERRUPT Mode ([INTSEL] = 0)

[SE_PU]	[INTPOL]	INTERRUPT CLEAR	INTERRUPT SET
0	0	High Impedance	0
0	1	0	High Impedance
1	0	1	0
1	1	0	1

Table 8. HDQ Pin in INTERRUPT Mode ([INTSEL] = 1)

[INTPOL]	INTERRUPT CLEAR	INTERRUPT SET
0	High Impedance	0
1	0	High Impedance

Table 9. INTERRUPT Mode Fault Conditions

INTERRUPT CONDITION	Flags() STATUS BIT	ENABLE CONDITION	COMMENT
SOC1 Set/Clear	[SOC1]	Always	The SOC1 Set/Clear interrupt is based on the [SOC1] Flag condition when <i>RemainingCapacity()</i> reaches the SOC1 Set or Clear threshold in the data flash.
Over Temperature Charge	[OTC]	OT Chg Time ≠ 0	The [OTC] Flag is set/clear based on conditions specified in Over-Temperature: Charge .
Over Temperature Discharge	[OTD]	OT Dsg Time ≠ 0	The [OTD] Flag is set/clear based on conditions specified in Over-Temperature: Discharge .
Battery High	[BATHI]	Always	The [BATHI] Flag is set/clear based on conditions specified in Battery Level Indication .
Battery Low	[BATLOW]	Always	The [BATLOW] Flag is set/clear based on conditions specified in Battery Level Indication .
Internal Short Detection	[ISD]	[SE_ISD] = 1 in Pack Configuration B	The [SE_ISD] Flag is set/clear based on conditions specified in Internal Short Detection .
Tab disconnection detection	[TDD]	[SE_TDD] = 1 in Pack Configuration B	The [TDD] Flag is set/clear based on conditions specified in Tab Disconnection Detection .

9.4.1.3 Battery Level Indication

The bq27545 can indicate when battery voltage has fallen below or risen above predefined thresholds. The [BATHI] of *Flags()* is set high to indicate *Voltage()* is above the **BH Set Volt Threshold** for a predefined duration set in the **BH Volt Time**. This flag returns to low once battery voltage is below or equal the **BH Clear Volt threshold**. TI recommends configuring the **BH Set Volt Threshold** higher than the **BH Clear Volt threshold** to provide proper voltage hysteresis.

The *[BATLOW]* of *Flags()* is set high to indicate *Voltage()* is below the **BL Set Volt Threshold** for predefined duration set in the **BL Volt Time**. This flag returns to low once battery voltage is above or equal the **BL Clear Volt threshold**. TI recommends configuring the **BL Set Volt Threshold** lower than the **BL Clear Volt threshold** to provide proper voltage hysteresis.

The *[BATHI]* and *[BATLOW]* flags can be configured to control the interrupt pin (SE or HDQ) by enabling INTERRUPT mode. Refer to [INTERRUPT Mode](#) for details.

9.4.1.4 Internal Short Detection

The bq27545-G1 can indicate detection of an internal battery short by setting the *[SE_ISD]* bit in **Pack Configuration B**. The device compares the self-discharge current calculated based *StateOfCharge()* in RELAX mode and *AverageCurrent()* measured in the system. The self-discharge rate is measured at 1 hour interval. When battery *SelfDischargeCurrent()* is less than the predefined (**-Design Capacity/ISD Current** threshold), the *[ISD]* of *Flags()* is set high. The *[ISD]* of *Flags()* can be configured to control interrupt pin (SE or HDQ) by enabling INTERRUPT mode. Refer to [INTERRUPT Mode](#) for details.

9.4.1.5 Tab Disconnection Detection

The bq27545-G1 can indicate tab disconnection by detecting change of *StateOfHealth()*. This feature is enabled by setting *[SE_TDD]* bit in **Pack Configuration B**. The *[TDD]* of *Flags()* is set when the ratio of current *StateOfHealth()* divided by the previous *StateOfHealth()* reported is less than **TDD SOH Percent**. The *[TDD]* of *Flags()* can be configured to control an interrupt pin (SE or HDQ) by enabling INTERRUPT mode. Refer to [INTERRUPT Mode](#) for details.

9.4.2 Temperature Measurement and the TS Input

The bq27545-G1 measures battery temperature through the TS input to supply battery temperature status information to the fuel gauging algorithm and charger-control sections of the gauge. Alternatively, the gauge can also measure internal temperature through its on-chip temperature sensor, but only if the *[TEMPS]* bit of **Pack Configuration** register is cleared.

Regardless of which sensor is used for measurement, a system processor can request the current battery temperature by calling the *Temperature()* function (see [Authentication](#) for specific information).

The thermistor circuit requires the use of an external 10-k Ω thermistor with negative temperature coefficient (NTC) thermistor with $R_{25} = 10 \text{ k}\Omega \pm 1\%$ and $B_{25/85} = 3435 \text{ k}\Omega \pm 1\%$ (such as Semitec 103AT) that connects between the V_{CC} and TS pins. Additional circuit information for connecting the thermistor to the bq27545 is shown in the [Figure 9](#).

9.4.3 Over-Temperature Indication

9.4.3.1 Over-Temperature: Charge

If during charging, *Temperature()* reaches the threshold of **OT Chg** for a period of **OT Chg Time** and *AverageCurrent()* \geq **Chg Current Threshold**, then the *[OTC]* bit of *Flags()* is set. When *Temperature()* falls to **OT Chg Recovery**, the *[OTC]* of *Flags()* is reset.

If **OT Chg Time** = 0, the feature is disabled.

9.4.3.2 Over-Temperature: Discharge

If during discharging, *Temperature()* reaches the threshold of **OT Dsg** for a period of **OT Dsg Time**, and *AverageCurrent()* \leq **-Dsg Current Threshold**, then the *[OTD]* bit of *Flags()* is set. When *Temperature()* falls to **OT Dsg Recovery**, the *[OTD]* bit of *Flags()* is reset.

If **OT Dsg Time** = 0, the feature is disabled.

9.4.4 Charging and Charge Termination Indication

9.4.4.1 Detection Charge Termination

For proper bq27545-G1 operation, the cell charging voltage must be specified by the user. The default value for this variable is in the data flash **Charging Voltage**.

The bq27545-G1 detects charge termination when (1) during 2 consecutive periods of **Current Taper Window**, the *AverageCurrent()* is **< Taper Current**, (2) during the same periods, the accumulated change in capacity **> 0.25mAh/Current Taper Window**, and (3) *Voltage()* **> Charging Voltage – Taper Voltage**. When this occurs, the *[CHG]* bit of *Flags()* is cleared. Also, if the *[RMFCC]* bit of **Pack Configuration** is set, *RemainingCapacity()* is set equal to *FullChargeCapacity()*. When **TCA_Set** is set to –1, it disables the use of the charger alarm threshold. In that case, **Terminate Charge** is set when the taper condition is detected. When **FC_Set** is set to –1, it disables the use of the full charge detection threshold. In that case, the *[FC]* bit is not set until the taper condition is met.

9.4.4.2 Charge Inhibit

The bq27545-G1 can indicate when battery temperature has fallen below or risen above predefined thresholds (**Charge Inhibit Temp Low** and **Charge Inhibit Temp High**, respectively). In this mode, the *[CHG_INH]* of *Flags()* is made high to indicate this condition, and is returned to its low state, once battery temperature returns to the range [**Charge Inhibit Temp Low + Temp Hys**, **Charge Inhibit Temp High – Temp Hys**].

9.4.5 Power Modes

The bq27545-G1 has four power modes: NORMAL, SLEEP, FULLSLEEP, and HIBERNATE.

- In NORMAL mode, the bq27545-G1 is fully powered and can execute any allowable task.
- In SLEEP mode, the fuel gauge exists in a reduced-power state, periodically taking measurements and performing calculations.
- During FULLSLEEP mode, the bq27545-G1 periodically takes data measurements and updates its data set. However, a majority of its time is spent in an idle condition.
- In HIBERNATE mode, the fuel gauge is in a very low-power state, but can be awoken by communication or certain I/O activity.

The relationship between these modes is shown in [Figure 7](#). Details are described in the sections that follow.

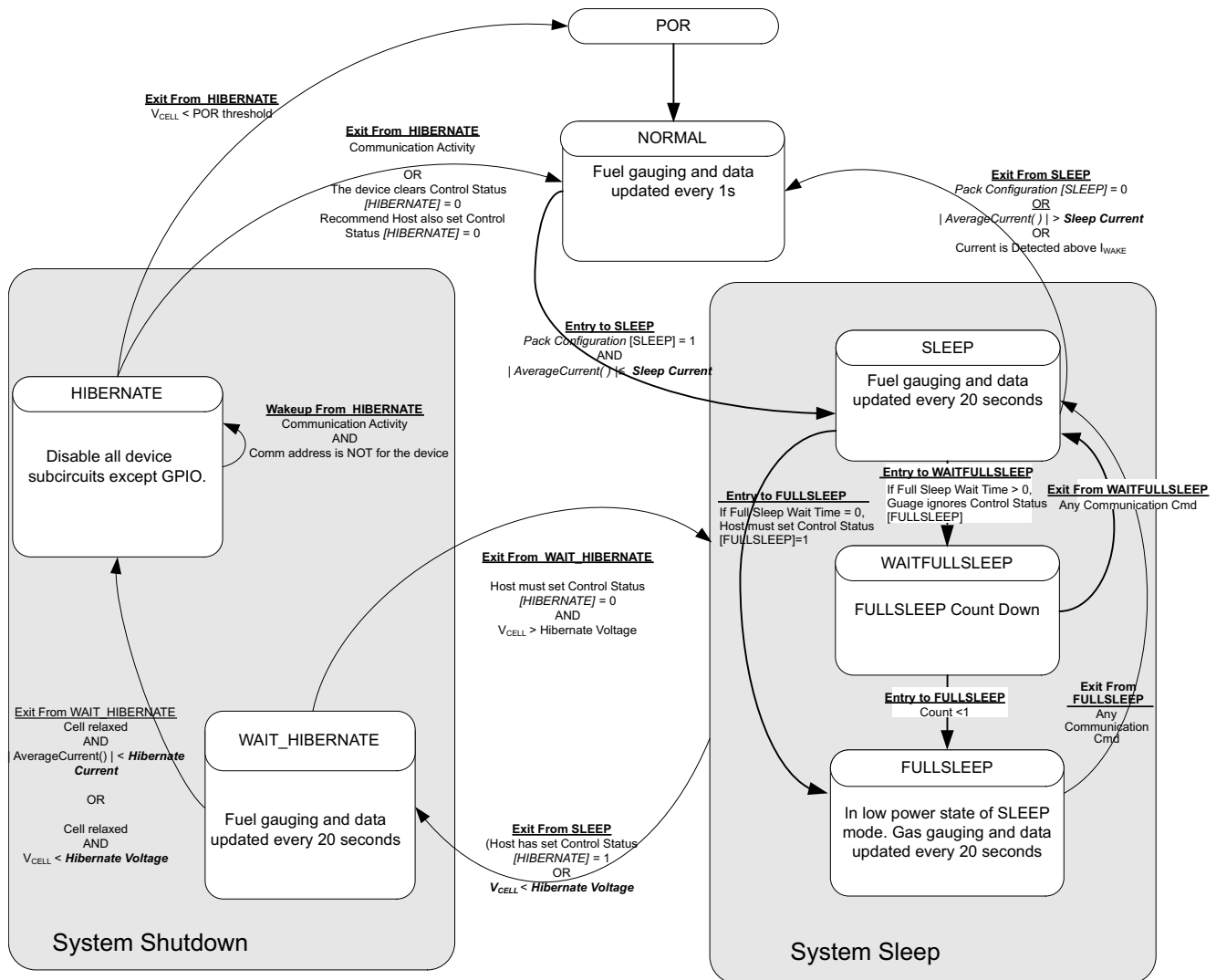

Figure 7. Power Mode Diagram

9.4.5.1 NORMAL Mode

The fuel gauge is in NORMAL mode when not in any other power mode. During this mode, *AverageCurrent()*, *Voltage()*, and *Temperature()* measurements are taken, and the interface data set is updated. Decisions to change states are also made. This mode is exited by activating a different power mode.

Because the gauge consumes the most power in NORMAL mode, the Impedance Track algorithm minimizes the time the fuel gauge remains in this mode.

9.4.5.2 SLEEP Mode

SLEEP mode is entered automatically if the feature is enabled (*Pack Configuration [SLEEP]* = 1) and *AverageCurrent()* is below the programmable level **Sleep Current**. Once entry into SLEEP mode has been qualified, but before entering it, the bq27545-G1 performs an ADC autocalibration to minimize offset.

While in SLEEP mode, the fuel gauge can suspend serial communications as much as 4 ms by holding the comm line(s) low. This delay is necessary to correctly process host communication, because the fuel gauge processor is mostly halted in SLEEP mode.

During the SLEEP mode, the bq27545-G1 periodically takes data measurements and updates its data set. However, a majority of its time is spent in an idle condition.

The bq27545-G1 exits SLEEP if any entry condition is broken, specifically when (1) *AverageCurrent()* rises above **Sleep Current**, or (2) a current in excess of I_{WAKE} through R_{SENSE} is detected when the I_{wake} comparator is enabled.

9.4.5.3 FULLSLEEP Mode

FULLSLEEP mode is entered automatically when the bq27545-G1 is in SLEEP mode and the timer counts down to 0 (*Full Sleep Wait Time* > 0). FULLSLEEP mode is entered immediately after entry to SLEEP if **Full Sleep Wait Time** is set to 0 and the host sets the [FULLSLEEP] bit in the CONTROL_STATUS register using the SET_FULLSLEEP subcommand.

The gauge exits the FULLSLEEP mode when there is any communication activity. The [FULLSLEEP] bit can remain set (*Full Sleep Wait Time* > 0) or be cleared (*Full Sleep Wait Time* ≤ 0) after exit of FULLSLEEP mode. Therefore, EVSW communication activity might cause the gauge to exit FULLSLEEP MODE and display the [FULLSLEEP] bit as clear. The execution of SET_FULLSLEEP to set [FULLSLEEP] bit is required when *Full Sleep Wait Time* ≤ 0 to re-enter FULLSLEEP mode. The FULLSLEEP mode can be verified by measuring the current consumption of the gauge. In this mode, the high frequency oscillator is turned off. The power consumption is further reduced in this mode compared to the SLEEP mode.

While in FULLSLEEP mode, the fuel gauge can suspend serial communications as much as 4 ms by holding the comm line(s) low. This delay is necessary to correctly process host communication, because the fuel gauge processor is mostly halted in SLEEP mode.

The bq27545-G1 exits FULLSLEEP if any entry condition is broken, specifically when (1) *AverageCurrent()* rises above **Sleep Current**, or (2) a current in excess of I_{WAKE} through R_{SENSE} is detected when the I_{wake} comparator is enabled.

9.4.5.4 HIBERNATE Mode

HIBERNATE mode should be used for long-term pack storage or when the host system must enter a low-power state, and minimal gauge power consumption is required. This mode is ideal when the host is set to its own HIBERNATE, SHUTDOWN, or OFF mode. The gauge waits to enter HIBERNATE mode until it has taken a valid OCV measurement (cell relaxed) and the magnitude of the average cell current has fallen below *Hibernate Current*. When the conditions are met, the fuel gauge can enter HIBERNATE due to either low cell voltage or by having the [HIBERNATE] bit of the CONTROL_STATUS register set. The gauge will remain in HIBERNATE mode until any communication activity appears on the communication lines and the address is for bq27545. In addition, the SE pin SHUTDOWN mode function is supported only when the fuel gauge enters HIBERNATE due to low cell voltage.

When the gauge wakes up from HIBERNATE mode, the [HIBERNATE] bit of the CONTROL_STATUS register is cleared. The host is required to set the bit to allow the gauge to re-enter HIBERNATE mode if desired.

Because the fuel gauge is dormant in HIBERNATE mode, the battery should not be charged or discharged in this mode, because any changes in battery charge status will not be measured. If necessary, the host equipment can draw a small current (generally infrequent and less than 1 mA, for purposes of low-level monitoring and updating); however, the corresponding charge drawn from the battery will not be logged by the gauge. Once the gauge exits to NORMAL mode, the IT algorithm will take about 3 seconds to re-establish the correct battery capacity and measurements, regardless of the total charge drawn in HIBERNATE mode. During this period of re-establishment, the gauge reports values previously calculated before entering HIBERNATE mode. The host can identify exit from HIBERNATE mode by checking if *Voltage()* < **Hibernate Voltage** or [HIBERNATE] bit is cleared by the gauge.

If a charger is attached, the host should immediately take the fuel gauge out of HIBERNATE mode before beginning to charge the battery. Charging the battery in HIBERNATE mode will result in a notable gauging error that will take several hours to correct. It is also recommended to minimize discharge current during exit from Hibernate.

9.4.6 Power Control

9.4.6.1 Reset Functions

When the bq27545-G1 detects a software reset by sending [RESET] Control() subcommand, it determines the type of reset and increments the corresponding counter. This information is accessible by issuing the command *Control()* function with the RESET_DATA subcommand.

9.4.6.2 Wake-Up Comparator

The wake-up comparator is used to indicate a change in cell current while the bq27545-G1 is in SLEEP mode. **Pack Configuration** uses bits **[RSNS1]–[RSNS0]** to set the sense resistor selection. **Pack Configuration** also uses the **[IWAKE]** bit to select one of two possible voltage threshold ranges for the given sense resistor selection. An internal interrupt is generated when the threshold is breached in either charge or discharge directions. Setting both **[RSNS1]** and **[RSNS0]** to 0 disables this feature.

Table 10. I_{WAKE} Threshold Settings⁽¹⁾

IWAKE	RSNS1	RSNS0	Vth(SRP-SRN)
0	0	0	Disabled
1	0	0	Disabled
0	0	1	1 mV or –1 mV
1	0	1	+2.2 mV or –2.2 mV
0	1	0	+2.2 mV or –2.2 mV
1	1	0	+4.6 mV or –4.6 mV
0	1	1	+4.6 mV or –4.6 mV
1	1	1	+9.8 mV or –9.8 mV

(1) The actual resistance value vs the setting of the sense resistor is not important just the actual voltage threshold when calculating the configuration. The voltage thresholds are typical values under room temperature.

9.4.6.3 Flash Updates

Data flash can only be updated if $Voltage() \geq \text{Flash Update OK Voltage}$. Flash programming current can cause an increase in LDO dropout. The value of **Flash Update OK Voltage** should be selected such that the bq27545-G1 V_{CC} voltage does not fall below its minimum of 2.4 V during Flash write operations.

9.4.7 Autocalibration

The bq27545-G1 provides an autocalibration feature that will measure the voltage offset error across SRP and SRN from time-to-time as operating conditions change. It subtracts the resulting offset error from normal sense resistor voltage, V_{SR} , for maximum measurement accuracy.

Autocalibration of the ADC begins on entry to SLEEP mode, except if $Temperature() \leq 5^{\circ}\text{C}$ or $Temperature() \geq 45^{\circ}\text{C}$.

The fuel gauge also performs a single offset calibration when (1) the condition of $AverageCurrent() \leq 100 \text{ mA}$ and (2) {voltage change because last offset calibration $\geq 256 \text{ mV}$ } or {temperature change because last offset calibration is greater than 8°C for ≥ 60 seconds}.

Capacity and current measurements will continue at the last measured rate during the offset calibration when these measurements cannot be performed. If the battery voltage drops more than 32 mV during the offset calibration, the load current has likely increased considerably; hence, the offset calibration will be aborted.

9.4.8 Communications

9.4.8.1 Authentication

The bq27545-G1 can act as a SHA-1/HMAC authentication slave by using its internal engine. Sending a 160-bit SHA-1 challenge message to the bq27545-G1 will cause the gauge to return a 160-bit digest, based upon the challenge message and a hidden, 128-bit plain-text authentication key. If this digest matches an identical one generated by a host or dedicated authentication master, and when operating on the same challenge message and using the same plain text keys, the authentication process is successful.

9.4.8.2 Key Programming (Data Flash Key)

By default, the bq27545-G1 contains a default plain-text authentication key of 0x0123456789ABCDEFEDCBA9876543210. This default key is intended for development purposes. It should be changed to a secret key and the part immediately sealed, before putting a pack into operation. Once written, a new plain-text key cannot be read again from the fuel gauge while in SEALED mode.

Once the bq27545-G1 is UNSEALED, the authentication key can be changed from its default value by writing to the *Authenticate()* Extended Data Command locations. A 0x00 is written to *BlockDataControl()* to enable the authentication data commands. The *DataFlashClass()* is issued 112 (0x70) to set the Security class. Up to 32 bytes of data can be read directly from the *BlockData()* (0x40...0x5F) and the authentication key is located at 0x48 (0x40 + 0x08 offset) to 0x57 (0x40 + 0x17 offset). The new authentication key can be written to the corresponding locations (0x48 to 0x57) using the *BlockData()* command. The data is transferred to the data flash when the correct checksum for the whole block (0x40 to 0x5F) is written to *BlockDataChecksum()* (0x60). The checksum is (255 – x) where x is the 8-bit summation of the *BlockData()* (0x40 to 0x5F) on a byte-by-byte basis. Once the authentication key is written, the gauge can then be SEALED again.

9.4.8.3 Key Programming (Secure Memory Key)

As the name suggests, the bq27545-G1 secure-memory authentication key is stored in the secure memory of the bq27545-G1. If a secure-memory key has been established, only this key can be used for authentication challenges (the programmable data flash key is not available). The selected key can only be established/programmed by special arrangements with TI, using the TI's *Secure B-to-B Protocol*. The secure-memory key can never be changed or read from the bq27545-G1.

9.4.8.4 Executing An Authentication Query

To execute an authentication query in UNSEALED mode, a host must first write 0x01 to the *BlockDataControl()* command, to enable the authentication data commands. If in SEALED mode, 0x00 must be written to *DataFlashBlock()*, instead.

Next, the host writes a 20-byte authentication challenge to the *Authenticate()* address locations (0x40 through 0x53). After a valid checksum for the challenge is written to *AuthenticateChecksum()*, the bq27545 uses the challenge to perform the SHA-1/HMAC computation, in conjunction with the programmed key. The bq27545-G1 completes the SHA-1/HMAC computation and write the resulting digest to *Authenticate()*, overwriting the pre-existing challenge. The host should wait at least 45 ms to read the resulting digest. The host may then read this response and compare it against the result created by its own parallel computation.

9.4.9 HDQ Single-Pin Serial Interface

The HDQ interface is an asynchronous return-to-one protocol where a processor sends the command code to the bq27545-G1. With HDQ, the least significant bit (LSB) of a data byte (command) or word (data) is transmitted first. The DATA signal on pin 12 is open drain and requires an external pullup resistor. The 8-bit command code consists of two fields: the 7-bit HDQ command code (bits 0–6) and the 1-bit R/W field (MSB bit 7). The R/W field directs the bq27545-G1 either to

- Store the next 8 or 16 bits of data to a specified register or
- Output 8 bits of data from the specified register

The HDQ peripheral can transmit and receive data as either an HDQ master or slave.

HDQ serial communication is normally initiated by the host processor sending a break command to the bq27545-G1. A break is detected when the DATA pin is driven to a logic-low state for a time $t_{(B)}$ or greater. The DATA pin should then be returned to its normal ready high logic state for a time $t_{(BR)}$. The bq27545-G1 is now ready to receive information from the host processor.

The bq27545-G1 is shipped in the I²C mode. TI provides tools to enable the HDQ peripheral. The *HDQ Communication Basics Application Report* ([SLUA408A](#)) provides details of HDQ communication basics.

9.4.10 HDQ Host Interruption Feature

The default bq27545-G1 behaves as an HDQ slave only device when HDQ mode is enabled. If the HDQ interrupt function is enabled, the bq27545-G1 is capable of mastering and also communicating to a HDQ device. There is no mechanism for negotiating who is to function as the HDQ master and take care to avoid message collisions. The interrupt is signaled to the host processor with the bq27545-G1 mastering an HDQ *message*. This message is a fixed message that will be used to signal the interrupt condition. The message itself is 0x80 (slave write to register 0x00) with no data byte being sent as the command is not intended to convey any status of the interrupt condition. The HDQ interrupt function is disabled by default and must be enabled by command.

When the SET_HDQINTEN subcommand is received, the bq27545-G1 will detect any of the interrupt conditions and assert the interrupt at one second intervals until the CLEAR_HDQINTEN command is received or the count of HDQHostIntrTries has lapsed.

The number of tries for interrupting the host is determined by the data flash parameter named **HDQHostIntrTries**.

9.4.10.1 Low Battery Capacity

This feature will work identically to SOC1. It will use the same data flash entries as SOC1 and will trigger interrupts as long as SOC1 = 1 and *HDQIntEN*=1.

9.4.10.2 Temperature

This feature will trigger an interrupt based on the OTC (Over-Temperature in Charge) or OTD (Over-Temperature in Discharge) condition being met. It uses the same data flash entries as OTC or OTD and will trigger interrupts as long as either the OTD or OTC condition is met and *HDQIntEN*=1.

9.5 Programming

9.5.1 I²C Interface

The fuel gauge supports the standard I²C read, incremental read, one-byte write quick read, and functions. The 7-bit device address (ADDR) is the most significant 7 bits of the hex address and is fixed as 1010101. The 8-bit device address is therefore 0xAA or 0xAB for write or read, respectively.

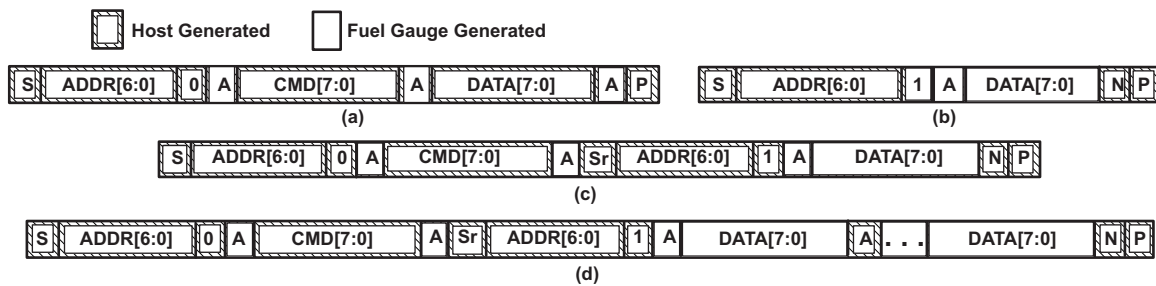

Figure 8. Supported I²C Formats: (A) 1-Byte Write, (B) Quick Read, (C) 1 Byte-Read, And (D) Incremental Read (S = Start, Sr = Repeated Start, A = Acknowledge, N = No Acknowledge, And P = Stop).

The *quick read* returns data at the address indicated by the address pointer. The address pointer, a register internal to the I²C communication engine, increments whenever data is acknowledged by the bq27545-G1 or the I²C master. *Quick writes* function in the same manner and are a convenient means of sending multiple bytes to consecutive command locations (such as two-byte commands that require two bytes of data).

Attempt to write a read-only address (NACK after data sent by master):



Attempt to read an address above 0x7F (NACK command):



Attempt at incremental writes (NACK all extra data bytes sent):



Incremental read at the maximum allowed read address:

Programming (continued)

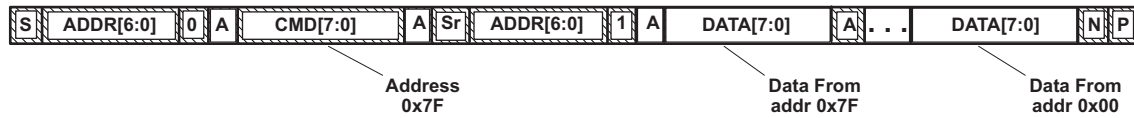

The I²C engine releases both SDA and SCL if the I²C bus is held low for $t_{(BUSERR)}$. If the fuel gauge was holding the lines, releasing them frees the master to drive the lines. If an external condition is holding either of the lines low, the I²C engine enters the low-power sleep mode.

9.5.1.1 I²C Time-Out

The I²C engine will release both SDA and SCL if the I²C bus is held low for about 2 seconds. If the bq27545-G1 was holding the lines, releasing them will free for the master to drive the lines.

9.5.1.2 I²C Command Waiting Time

To make sure the correct results of a command with the 400-KHz I²C operation, a proper waiting time should be added between issuing command and reading results. For subcommands, the following diagram shows the waiting time required between issuing the control command the reading the status with the exception of the checksum command. A 100-ms waiting time is required between the checksum command and reading result. For read-write standard commands, a minimum of 2 seconds is required to get the result updated. For read-only standard commands, there is no waiting time required, but the host should not issue all standard commands more than two times per second. Otherwise, the gauge could result in a reset issue due to the expiration of the watchdog timer.

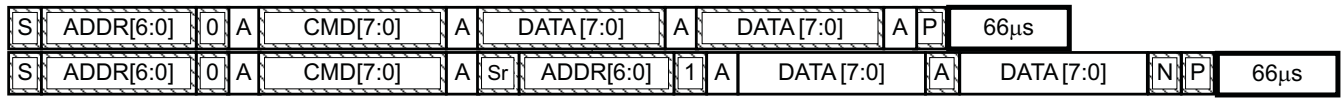

Waiting time between control subcommand and reading results

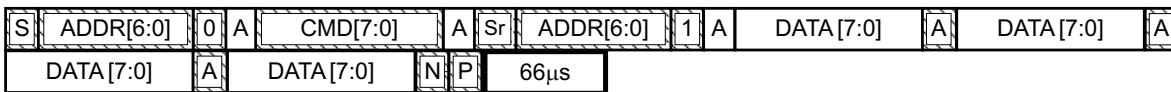

Waiting time between continuous reading results

9.5.1.3 I²C Clock Stretching

I²C clock stretches can occur during all modes of fuel gauge operation. In the SLEEP and HIBERNATE modes, a short clock stretch will occur on all I²C traffic as the device must wake up to process the packet. In NORMAL and SLEEP+ modes, clock stretching will only occur for packets addressed for the fuel gauge. The timing of stretches will vary as interactions between the communicating host and the gauge are asynchronous. The I²C clock stretches may occur after start bits, the ACK/NAK bit and first data bit transmit on a host read cycle. The majority of clock stretch periods are small (≤ 4 ms) as the I²C interface peripheral and CPU firmware perform normal data flow control. However, less frequent but more significant clock stretch periods may occur when data flash (DF) is being written by the CPU to update the resistance (Ra) tables and other DF parameters such as Qmax. Due to the organization of DF, updates must be written in data blocks consisting of multiple data bytes.

An Ra table update requires erasing a single page of DF, programming the updated Ra table and a flag. The potential I²C clock stretching time is 24-ms max. This includes 20-ms page erase and 2-ms row programming time (x2 rows). The Ra table updates occur during the discharge cycle and at up to 15 resistance grid points that occur during the discharge cycle.

Programming (continued)

A DF block write typically requires a maximum of 72 ms. This includes copying data to a temporary buffer and updating DF. This temporary buffer mechanism is used to protect from power failure during a DF update. The first part of the update requires 20 ms time to erase the copy buffer page, 6 ms to write the data into the copy buffer and the program progress indicator (2 ms for each individual write). The second part of the update is writing to the DF and requires 44-ms DF block update time. This includes a 20 ms each page erase for two pages and 2 ms each row write for two rows.

In the event that a previous DF write was interrupted by a power failure or reset during the DF write, an additional 44-ms max DF restore time is required to recover the data from a previously interrupted DF write. In this power failure recovery case, the total I²C clock stretching is 116-ms max.

Another case where I²C clock stretches is at the end of discharge. The update to the last discharge data will go through the DF block update twice because two pages are used for the data storage. The clock stretching in this case is 144-ms max. This occurs if there has been a Ra table update during the discharge.

9.5.2 Data Commands

9.5.2.1 Standard Data Commands

The bq27545-G1 uses a series of 2-byte standard commands to enable system reading and writing of battery information. Each standard command has an associated command-code pair, as indicated in [Table 11](#). Each protocol has specific means to access the data at each Command Code. DataRAM is updated and read by the gauge only once per second. Standard commands are accessible in NORMAL operation mode.

Table 11. Standard Commands

NAME		COMMAND CODE	UNIT	SEALED ACCESS
<i>Control()</i>	CNTL	0x00/0x01	N/A	R/W
<i>AtRate()</i>	AR	0x02/0x03	mA	R/W
<i>UnfilteredSOC()</i>	UFSOC	0x04/0x05	%	R
<i>Temperature()</i>	TEMP	0x06/0x07	0.1K	R
<i>Voltage()</i>	VOLT	0x08/0x09	mV	R
<i>Flags()</i>	FLAGS	0x0A/0x0B	N/A	R
<i>NomAvailableCapacity()</i>	NAC	0x0C/0x0D	mAh	R
<i>FullAvailableCapacity()</i>	FAC	0x0E/0x0F	mAh	R
<i>RemainingCapacity()</i>	RM	0x10/0x11	mAh	R
<i>FullChargeCapacity()</i>	FCC	0x12/0x13	mAh	R
<i>AverageCurrent()</i>	AI	0x14/0x15	mA	R
<i>TimeToEmpty()</i>	TTE	0x16/0x17	Minutes	R
<i>FilteredFCC()</i>	FFCC	0x18/0x19	mAh	R
<i>StandbyCurrent()</i>	SI	0x1A/0x1B	mA	R
<i>UnfilteredFCC()</i>	UFFCC	0x1C/0x1D	mAh	R
<i>MaxLoadCurrent()</i>	MLI	0x1E/0x1F	mA	R
<i>UnfilteredRM()</i>	UFRM	0x20/0x21	mAh	R
<i>FilteredRM()</i>	FRM	0x22/0x23	mAh	R
<i>AveragePower()</i>	AP	0x24/0x25	mW/cW	R
<i>InternalTemperature()</i>	INTTEMP	0x28/0x29	0.1°K	R
<i>CycleCount()</i>	CC	0x2A/0x2B	Counts	R
<i>StateOfCharge()</i>	SOC	0x2C/0x2D	%	R
<i>StateOfHealth()</i>	SOH	0x2E/0x2F	%/num	R
<i>PassedCharge()</i>	PCHG	0x34/0x35	mAh	R
<i>DOD0()</i>	DOD0	0x36/0x37	HEX#	R
<i>SelfDischargeCurrent()</i>	SDSG	0x38/0x39	mA	R

9.5.2.1.1 Control(): 0x00 and 0x01

Issuing a *Control()* command requires a subsequent 2-byte subcommand. These additional bytes specify the particular control function desired. The *Control()* command allows the system to control specific features of the bq27545-G1 during normal operation and additional features when the bq27545-G1 is in different access modes, as described in [Table 12](#).

Table 12. Control() Subcommands

CNTL FUNCTION	CNTL DATA	SEALED ACCESS	DESCRIPTION
CONTROL_STATUS	0x0000	Yes	Reports the status of DF Checksum, Hibernate, IT, and so on
DEVICE_TYPE	0x0001	Yes	Reports the device type of 0x0545 (indicating bq27545-G1)
FW_VERSION	0x0002	Yes	Reports the firmware version on the device type
HW_VERSION	0x0003	Yes	Reports the hardware version of the device type
Reserved	0x0004	No	Not to be used
RESET_DATA	0x0005	Yes	Returns reset data
Reserved	0x0006	No	Not to be used
PREV_MACWRITE	0x0007	Yes	Returns previous <i>Control()</i> subcommand code
CHEM_ID	0x0008	Yes	Reports the chemical identifier of the Impedance Track configuration
BOARD_OFFSET	0x0009	No	Forces the device to measure and store the board offset
CC_OFFSET	0x000A	No	Forces the device to measure internal CC offset
CC_OFFSET_SAVE	0x000B	No	Forces the device to store the internal CC offset
DF_VERSION	0x000C	Yes	Reports the data flash version on the device
SET_FULLSLEEP	0x0010	Yes	Sets the <i>[FullSleep]</i> bit in Control Status register to 1
SET_HIBERNATE	0x0011	Yes	Forces CONTROL_STATUS <i>[HIBERNATE]</i> to 1
CLEAR_HIBERNATE	0x0012	Yes	Forces CONTROL_STATUS <i>[HIBERNATE]</i> to 0
SET_SHUTDOWN	0x0013	Yes	Enables the SE pin to change state
CLEAR_SHUTDOWN	0x0014	Yes	Disables the SE pin from changing state
SET_HDQINTEN	0x0015	Yes	Forces CONTROL_STATUS <i>[HDQIntEn]</i> to 1
CLEAR_HDQINTEN	0x0016	Yes	Forces CONTROL_STATUS <i>[HDQIntEn]</i> to 0
STATIC_CHEM_CHKSUM	0x0017	Yes	Calculates chemistry checksum
SEALED	0x0020	No	Places the bq27545-G1 in SEALED access mode
IT_ENABLE	0x0021	No	Enables the Impedance Track algorithm
CAL_ENABLE	0x002d	No	Toggle bq27545-G1 CALIBRATION mode
RESET	0x0041	No	Forces a full reset of the bq27545-G1
EXIT_CAL	0x0080	No	Exit bq27545-G1 CALIBRATION mode
ENTER_CAL	0x0081	No	Enter bq27545-G1 CALIBRATION mode
OFFSET_CAL	0x0082	No	Reports internal CC offset in CALIBRATION mode

9.5.2.1.1.1 CONTROL_STATUS: 0x0000

Instructs the fuel gauge to return status information to Control addresses 0x00 and 0x01. The status word includes the following information.

Table 13. CONTROL_STATUS Flags

	bit7	bit6	bit5	bit4	bit3	bit2	bit1	bit0
High Byte	SE	FAS	SS	CALMODE	CCA	BCA	RSVD	HDQHOSTIN
Low Byte	SHUTDWN	HIBERNATE	FULLSLEEP	SLEEP	LDMD	RUP_DIS	VOK	QEN

SE = Status bit indicating the SE pin is active. True when set. Default is 0.

FAS = Status bit indicating the bq27545-G1 is in FULL ACCESS SEALED state. Active when set.

SS = Status bit indicating the bq27545-G1 is in the SEALED State. Active when set.

CALMODE = Status bit indicating the calibration function is active. True when set. Default is 0.

CCA = Status bit indicating the bq27545-G1 Coulomb Counter Calibration routine is active. The CCA routine will take place approximately 1 minute after the initialization and periodically as gauging conditions change. Active when set.

BCA = Status bit indicating the bq27545-G1 Board Calibration routine is active. Active when set.

RSVD = Reserved

HDQHOSTIN = Status bit indicating the HDQ interrupt function is active. True when set. Default is 0.

SHUTDWN = Control bit indicating that the SET_SHUTDOWN command has been sent and the state of the SE pin can change to signal an external shutdown of the fuel gauge when conditions permit. (See the [SHUTDOWN Mode](#) section.)

HIBERNATE = Status bit indicating a request for entry into HIBERNATE from SLEEP mode has been issued. True when set. Default is 0.

FULLSLEEP = Status bit indicating the bq27545-G1 is in FULLSLEEP mode. True when set. The state can be detected by monitoring the power used by the bq27545-G1 because any communication will automatically clear it.

SLEEP = Status bit indicating the bq27545-G1 is in SLEEP mode. True when set.

LDMD = Status bit indicating the bq27545-G1 Impedance Track algorithm is using *CONSTANT-POWER* mode. True when set. Default is 0 (*CONSTANT-CURRENT* mode).

RUP_DIS = Status bit indicating the bq27545-G1 Ra table updates are disabled. True when set.

VOK = Status bit indicating cell voltages are OK for Qmax updates. True when set.

QEN = Status bit indicating the bq27545-G1 Qmax updates are enabled. True when set.

9.5.2.1.1.2 DEVICE_TYPE: 0x0001

Instructs the fuel gauge to return the device type to addresses 0x00 and 0x01. The bq27545-G1 device type returns 0x0545.

9.5.2.1.1.3 FW_VERSION: 0x0002

Instructs the fuel gauge to return the firmware version to addresses 0x00 and 0x01. The bq27545-G1 firmware version returns 0x0224.

9.5.2.1.1.4 HW_VERSION: 0x0003

Instructs the fuel gauge to return the hardware version to addresses 0x00 and 0x01. For bq27545-G1 0x0020 is returned.

9.5.2.1.1.5 RESET_DATA: 0x0005

Instructs the fuel gauge to return the number of resets performed to addresses 0x00 and 0x01.

9.5.2.1.1.6 PREV_MACWRITE: 0x0007

Instructs the fuel gauge to return the previous *Control()* subcommand written to addresses 0x00 and 0x01. The value returned is limited to less than 0x0020.

9.5.2.1.1.7 CHEM_ID: 0x0008

Instructs the fuel gauge to return the chemical identifier for the Impedance Track configuration to addresses 0x00 and 0x01.

9.5.2.1.1.8 BOARD_OFFSET: 0x0009

Instructs the fuel gauge to perform board offset calibration. During board offset calibration the *[BCA]* bit is set

9.5.2.1.1.9 CC_OFFSET: 0x000a

Instructs the fuel gauge to perform coulomb counter offset calibration. During calibration the *[CCA]* bit is set

9.5.2.1.1.10 CC_OFFSET_SAVE: 0x000b

Instructs the fuel gauge to save calibration coulomb counter offset after calibration.

9.5.2.1.1.11 DF_VERSION: 0x000c

Instructs the gas gauge to return the data flash version stored in **DF Config Version** to addresses 0x00 and 0x01.

9.5.2.1.1.12 SET_FULLSLEEP: 0x0010

Instructs the gas gauge to set the *FullSleep* bit in Control Status register to 1. This will allow the gauge to enter the FULLSLEEP power mode after the transition to SLEEP power state is detected. In FULLSLEEP mode, less power is consumed by disabling an oscillator circuit used by the communication engines. For HDQ communication one host message will be dropped. For I²C communications the first I²C message will incur a 6–8 ms clock stretch while the oscillator is started and stabilized. A communication to the device in FULLSLEEP will force the part back to the SLEEP mode.

9.5.2.1.1.13 SET_HIBERNATE: 0x0011

Instructs the fuel gauge to force the CONTROL_STATUS *[HIBERNATE]* bit to 1. This will allow the gauge to enter the HIBERNATE power mode after the transition to SLEEP power state is detected and the required conditions are met. The *[HIBERNATE]* bit is automatically cleared upon exiting from HIBERNATE mode.

9.5.2.1.1.14 CLEAR_HIBERNATE: 0x0012

Instructs the fuel gauge to force the CONTROL_STATUS *[HIBERNATE]* bit to 0. This will prevent the gauge from entering the HIBERNATE power mode after the transition to SLEEP power state is detected unless *Voltage()* is less than **Hibernate V**. It can also be used to force the gauge out of HIBERNATE mode.

9.5.2.1.1.15 SET_SHUTDOWN: 0x0013

Sets the CONTROL_STATUS *[SHUTDWN]* bit to 1, thereby enabling the SE pin to change state. The Impedance Track algorithm controls the setting of the SE pin, depending on whether the conditions are met for fuel gauge shutdown or not.

9.5.2.1.1.16 CLEAR_SHUTDOWN: 0x0014

Disables the SE pin from changing state. The SE pin is left in a high-impedance state.

9.5.2.1.1.17 SET_HDQINTEN: 0x0015

Instructs the fuel gauge to set the CONTROL_STATUS *[HDQIntEn]* bit to 1. This will enable the HDQ Interrupt function. When this subcommand is received, the device will detect any of the interrupt conditions and assert the interrupt at one second intervals until the CLEAR_HDQINTEN command is received or the count of HDQHostIntrTries has lapsed (default 3).

9.5.2.1.1.18 CLEAR_HDQINTEN: 0x0016

Instructs the fuel gauge to set the CONTROL_STATUS *[HDQIntEn]* bit to 0. This will disable the HDQ Interrupt function.

9.5.2.1.1.19 STATIC_CHEM_DF_CHKSUM: 0x0017

Instructs the fuel gauge to calculate chemistry checksum as a 16-bit unsigned integer sum of all static chemistry data. The most significant bit (MSB) of the checksum is masked yielding a 15-bit checksum. This checksum is compared with value stored in the data flash **Static Chem DF Checksum**. If the value matches, the MSB will be cleared to indicate pass. If it does not match, the MSB will be set to indicate failure. The checksum can be used to verify the integrity of the chemistry data stored internally.

9.5.2.1.1.20 SEALED: 0x0020

Instructs the gas gauge to transition from UNSEALED state to SEALED state. The gas gauge should always be set to SEALED state for use in customer's end equipment as it prevents spurious writes to most Standard Commands and blocks access to most data flash.

9.5.2.1.1.21 IT ENABLE: 0x0021

This command forces the fuel gauge to begin the Impedance Track algorithm, sets bit 2 of **UpdateStatus** and causes the *[VOK]* and *[QEN]* flags to be set in the CONTROL_STATUS register. *[VOK]* is cleared if the voltages are not suitable for a Qmax update. Once set, *[QEN]* cannot be cleared. This command is only available when the fuel gauge is UNSEALED and is typically enabled at the last step of production after system test is completed.

9.5.2.1.1.22 RESET: 0x0041

This command instructs the gas gauge to perform a full reset. This command is only available when the gas gauge is UNSEALED.

9.5.2.1.1.23 EXIT_CAL: 0x0080

This command instructs the gas gauge to exit CALIBRATION mode.

9.5.2.1.1.24 Enter_cal: 0x0081

This command instructs the gas gauge to enter CALIBRATION mode.

9.5.2.1.1.25 OFFSET_CAL: 0x0082

This command instructs the gas gauge to perform offset calibration.

9.5.2.1.2 AtRate(): 0x02 and 0x03

The *AtRate()* read/write-word function is the first half of a two-function command call-set used to set the *AtRate* value used in calculations made by the *AtRateTimeToEmpty()* function. The *AtRate()* units are in mA.

The *AtRate()* value is a signed integer, with negative values interpreted as a discharge current value. The *AtRateTimeToEmpty()* function returns the predicted operating time at the *AtRate* value of discharge. The default value for *AtRate()* is zero and will force *AtRateTimeToEmpty()* to return 65,535. Both the *AtRate()* and *AtRateTimeToEmpty()* commands should only be used in NORMAL mode.

9.5.2.1.3 UnfilteredSOC(): 0x04 And 0x05

This read-only function returns an unsigned integer value of the predicted remaining battery capacity expressed as a percentage of *UnfilteredFCC()*, with a range of 0 to 100%.

9.5.2.1.4 Temperature(): 0x06 And 0x07

This read-only function returns an unsigned integer value of the battery temperature in units of 0.1K measured by the fuel gauge and is used for fuel gauging algorithm. It reports either the *InternalTemperature()* or the external thermistor temperature depending on the setting of *[TEMPS]* bit in **Pack Configuration**.

9.5.2.1.5 Voltage(): 0x08 And 0x09

This read-only function returns an unsigned integer value of the measured cell-pack voltage in mV with a range of 0 to 6000 mV.

9.5.2.1.6 Flags(): 0x0a And 0x0b

This read-only function returns the contents of the gas-gauge status register, depicting the current operating status.

Table 14. Flags Bit Definitions

	bit7	bit6	bit5	bit4	bit3	bit2	bit1	bit0
High Byte	OTC	OTD	BATHI	BATLOW	CHG_INH	RSVD	FC	CHG
Low Byte	OCVTAKEN	ISD	TDD	HW1	HW0	SOC1	SOCF	DSG

OTC = Over-Temperature in Charge condition is detected. True when set. Refer to the Data Flash Safety Subclass parameters for threshold settings.

OTD = Over-Temperature in Discharge condition is detected. True when set. Refer to the Data Flash Safety Subclass parameters for threshold settings.

BATHI = Battery High bit indicating a high battery voltage condition. Refer to the Data Flash **BATTERY HIGH** parameters for threshold settings.

BATLOW = Battery Low bit indicating a low battery voltage condition. Refer to the Data Flash **BATTERY LOW** parameters for threshold settings.

CHG_INH = Charge Inhibit indicates the temperature is outside the range [*Charge Inhibit Temp Low, Charge Inhibit Temp High*]. True when set.

RSVD = Reserved.

FC = Full-charged is detected. FC is set when charge termination is reached and *FC Set%* = -1 (see [Charging and Charge Termination Indication](#)) or State of Charge is larger than **FC Set%** and *FC Set%* is not -1. True when set.

CHG = (Fast) charging allowed. True when set.

OCVTAKEN = Cleared on entry to RELAX mode and set to 1 when OCV measurement is performed in RELAX.

ISD = Internal Short is detected. True when set.

TDD = Tab Disconnect is detected. True when set.

HW[1:0] Device Identification. Default is 1/0

SOC1 = State-of-Charge-Threshold 1 (**SOC1 Set**) reached. True when set.

SOCF = State-of-Charge-Threshold Final (**SOCF Set %**) reached. True when set.

DSG = Discharging detected. True when set.

9.5.2.1.7 NominalAvailableCapacity(): 0x0c and 0x0d

This read-only command pair returns the uncompensated (less than C/20 load) battery capacity remaining. Units are mAh.

9.5.2.1.8 FullAvailableCapacity(): 0x0e and 0x0f

This read-only command pair returns the uncompensated (less than C/20 load) capacity of the battery when fully charged. Units are mAh. *FullAvailableCapacity()* is updated at regular intervals, as specified by the IT algorithm.

9.5.2.1.9 RemainingCapacity(): 0x10 and 0x11

This read-only command pair returns the compensated battery capacity remaining (*UnfilteredRM()*) when the [**SmoothEn**] bit in **Operating Configuration C** is cleared or filtered compensated battery capacity remaining (*FilteredRM()*) when [**SmoothEn**] is set. Units are mAh.

9.5.2.1.10 FullChargeCapacity(): 0x12 and 0x13

This read-only command pair returns the compensated capacity of fully charged battery (*UnfilteredFCC()*) when the [**SmoothEn**] bit in **Operating Configuration C** is cleared or filtered compensated capacity of fully charged battery (*FilteredFCC()*) when [**SmoothEn**] is set. Units are mAh. *FullChargeCapacity()* is updated at regular intervals, as specified by the IT algorithm.

9.5.2.1.11 AverageCurrent(): 0x14 and 0x15

This read-only command pair returns a signed integer value that is the average current flow through the sense resistor. It is updated every 1 second. Units are mA.

9.5.2.1.12 TimeToEmpty(): 0x16 And 0x17

This read-only function returns an unsigned integer value of the predicted remaining battery life at the present rate of discharge, in minutes. A value of 65,535 indicates battery is not being discharged.

9.5.2.1.13 FilteredFCC(): 0x18 And 0x19

This read-only command pair returns the filtered compensated capacity of the battery when fully charged when the **[SmoothEn]** bit in **Operating Configuration C** is set. Units are mAh. *FilteredFCC()* is updated at regular intervals, as specified by the IT algorithm.

9.5.2.1.14 StandbyCurrent(): 0x1a And 0x1b

This read-only function returns a signed integer value of the measured system standby current through the sense resistor. The *StandbyCurrent()* is an adaptive measurement. Initially it reports the standby current programmed in **Initial Standby**, and after spending some time in standby, reports the measured standby current.

The register value is updated every 1 second when the measured current is above the **Deadband** and is less than or equal to $2 \times$ **Initial Standby**. The first and last values that meet this criteria are not averaged in, because they may not be stable values. To approximate a 1 minute time constant, each new *StandbyCurrent()* value is computed by taking approximate 93% weight of the last standby current and approximate 7% of the current measured average current.

9.5.2.1.15 UnfilteredFCC(): 0x1c And 0x1d

This read-only command pair returns the compensated capacity of the battery when fully charged. Units are mAh. *UnFilteredFCC()* is updated at regular intervals, as specified by the IT algorithm.

9.5.2.1.16 MaxLoadCurrent(): 0x1e And 0x1f

This read-only function returns a signed integer value, in units of mA, of the maximum load conditions of the system. The *MaxLoadCurrent()* is an adaptive measurement which is initially reported as the maximum load current programmed in **Initial Max Load Current**. If the measured current is ever greater than **Initial Max Load Current**, then *MaxLoadCurrent()* updates to the new current. *MaxLoadCurrent()* is reduced to the average of the previous value and **Initial Max Load Current** whenever the battery is charged to full after a previous discharge to an SOC less than 50%. This prevents the reported value from maintaining an unusually high value.

9.5.2.1.17 UnfilteredRM(): 0x20 And 0x21

This read-only command pair returns the compensated battery capacity remaining. Units are mAh.

9.5.2.1.18 FilteredRM(): 0x22 And 0x23

This read-only command pair returns the filtered compensated battery capacity remaining when **[SmoothEn]** bit in **Operating Configuration C** is set. Units are mAh.

9.5.2.1.19 AveragePower(): 0x24 And 0x25

This read-word function returns an unsigned integer value of the average power of the current discharge. It is negative during discharge and positive during charge. A value of 0 indicates that the battery is not being discharged. The value is reported in units of mW (**Design Energy Scale = 1**) or cW (**Design Energy Scale = 10**).

9.5.2.1.20 InternalTemperature(): 0x28 And 0x29

This read-only function returns an unsigned integer value of the measured internal temperature of the device in units of 0.1K measured by the fuel gauge.

9.5.2.1.21 CycleCount(): 0x2a And 0x2b

This read-only function returns an unsigned integer value of the number of cycles the battery has experienced with a range of 0 to 65,535. One cycle occurs when accumulated discharge \geq **CC Threshold**.

9.5.2.1.22 StateOfCharge(): 0x2c And 0x2d

This read-only function returns an unsigned integer value of the predicted *RemainingCapacity()* expressed as a percentage of *FullChargeCapacity()*, with a range of 0 to 100%. The *StateOfCharge()* can be filtered or unfiltered because *RemainingCapacity()* and *FullChargeCapacity()* can be filtered or unfiltered based on *[SmoothEn]* bit selection.

9.5.2.1.23 StateOfHealth(): 0x2e And 0x2f

0x2e SOH percentage: this read-only function returns an unsigned integer value, expressed as a percentage of the ratio of predicted *FCC(25°C, SOH Load I)* over the *DesignCapacity()*. The *FCC(25°C, SOH Load I)* is the calculated full charge capacity at 25°C and the SOH current rate which is specified by *SOH Load I*. The range of the returned SOH percentage is 0x00 to 0x64, indicating 0 to 100% correspondingly.

9.5.2.1.24 PassedCharge(): 0x34 And 0x35

This signed integer indicates the amount of charge passed through the sense resistor because the last IT simulation in mAh.

9.5.2.1.25 Dod0(): 0x36 And 0x37

This unsigned integer indicates the depth of discharge during the most recent OCV reading.

9.5.2.1.26 SelfDischargeCurrent(): 0x38 And 0x39

This read-only command pair returns the signed integer value that estimates the battery self-discharge current.

9.5.3 Extended Data Commands

Extended commands offer additional functionality beyond the standard set of commands. They are used in the same manner; however unlike standard commands, extended commands are not limited to 2-byte words. The number of command bytes for a given extended command ranges in size from single to multiple bytes, as specified in [Table 15](#). For details on the SEALED and UNSEALED states, see [Access Modes](#).

Table 15. Extended Commands

NAME		COMMAND CODE	UNIT	SEALED ACCESS ^{(1) (2)}	UNSEALED ACCESS ^{(1) (2)}
Reserved	RSVD	0x38...0x39	N/A	R	R
PackConfig()	PCR	0x3a/0x3b	Hex	R	R
<i>DesignCapacity()</i>	DCAP	0x3c/0x3d	mAh	R	R
<i>DataFlashClass()</i> ⁽²⁾	DFCLS	0x3e	N/A	N/A	R/W
<i>DataFlashBlock()</i> ⁽²⁾	DFBLK	0x3f	N/A	R/W	R/W
<i>BlockData()/Authenticate()</i> ⁽³⁾	A/DF	0x40...0x53	N/A	R/W	R/W
<i>BlockData()/AuthenticateChecksum()</i> ⁽³⁾	ACKS/DFD	0x54	N/A	R/W	R/W
<i>BlockData()</i>	DFD	0x55...0x5f	N/A	R	R/W
<i>BlockDataChecksum()</i>	DFDCKS	0x60	N/A	R/W	R/W
<i>BlockDataControl()</i>	DFDCNTL	0x61	N/A	N/A	R/W
<i>DeviceNameLength()</i>	DNAMELEN	0x62	N/A	R	R
<i>DeviceName()</i>	DNAME	0x63...0x6c	N/A	R	R
Reserved	RSVD	0x6d...0x7f	N/A	R	R

(1) SEALED and UNSEALED states are entered through commands to *Control()* 0x00 and 0x01.

(2) In SEALED mode, data flash CANNOT be accessed through commands 0x3E and 0x3F.

(3) The *BlockData()* command area shares functionality for accessing general data flash and for using Authentication. See [Authentication](#) for more details.

9.5.3.1 *PackConfig(): 0x3a and 0x3b*

SEALED and UNSEALED Access: This command returns the value stored in **Pack Configuration** and is expressed in hex value.

9.5.3.2 *DesignCapacity(): 0x3c And 0x3d*

SEALED and UNSEALED Access: This command returns the value stored in **Design Capacity** and is expressed in mAh. This is intended to be the theoretical or nominal capacity of a new pack, but has no bearing on the operation of the fuel gauge functionality.

9.5.3.3 *DataFlashClass(): 0x3e*

This command sets the data flash class to be accessed. The Subclass ID to be accessed should be entered in hexadecimal.

SEALED Access: This command is not available in SEALED mode.

9.5.3.4 *DataFlashBlock(): 0x3f*

UNSEALED Access: This command sets the data flash block to be accessed. When 0x00 is written to *BlockDataControl()*, *DataFlashBlock()* holds the block number of the data flash to be read or written. Example: writing a 0x00 to *DataFlashBlock()* specifies access to the first 32 byte block and a 0x01 specifies access to the second 32 byte block, and so on.

SEALED Access: This command directs which data flash block is accessed by the *BlockData()* command. Writing a 0x00 to *DataFlashBlock()* specifies the *BlockData()* command transfers authentication data. Issuing a 0x01 or 0x02 instructs the *BlockData()* command to transfer **Manufacturer Info Block A or B** respectively.

9.5.3.5 *BlockData(): 0x40 Through 0x5f*

This command range is used to transfer data for data flash class access. This command range is the 32-byte data block used to access **Manufacturer Info Block A or B**. **Manufacturer Info Block A** is read only for the sealed access. UNSEALED access is read/write.

9.5.3.6 *BlockDataChecksum(): 0x60*

The host system should write this value to inform the device that new data is ready for programming into the specified data flash class and block.

UNSEALED Access: This byte contains the checksum on the 32 bytes of block data read or written to data flash. The least-significant byte of the sum of the data bytes written must be complemented ($[255 - x]$, for x the 8-bit summation of the *BlockData()* (0x40 to 0x5F) on a byte-by-byte basis.) before being written to 0x60.

SEALED Access: This byte contains the checksum for the 32 bytes of block data written to **Manufacturer Info Block A**. The least-significant byte of the sum of the data bytes written must be complemented ($[255 - x]$, for x the 8-bit summation of the *BlockData()* (0x40 to 0x5F) on a byte-by-byte basis.) before being written to 0x60.

9.5.3.7 *BlockDataControl(): 0x61*

UNSEALED Access: This command is used to control data flash access mode. The value determines the data flash to be accessed. Writing 0x00 to this command enables *BlockData()* to access general data flash.

SEALED Access: This command is not available in SEALED mode.

9.5.3.8 *DeviceNameLength(): 0x62*

UNSEALED and SEALED Access: This byte contains the length of the **Device Name**.

9.5.3.9 *DeviceName(): 0x63 Through 0x6c*

UNSEALED and SEALED Access: This block contains the device name that is programmed in **Device Name**.

9.5.3.10 *Reserved: 0x6a Through 0x7f*

Reserved Area. Not available for customer access.

9.5.4 Data Flash Interface

9.5.4.1 Accessing the Data Flash

The bq27545-G1 data flash is a non-volatile memory that contains initialization, default, cell status, calibration, configuration, and user information. The data flash can be accessed in several different ways, depending on what mode the bq27545-G1 is operating in and what data is being accessed.

Commonly accessed data flash memory locations, frequently read by a system, are conveniently accessed through specific instructions, already described in [Data Commands](#). These commands are available when the bq27545-G1 is either in UNSEALED or SEALED modes.

Most data flash locations, however, are only accessible in UNSEALED mode by use of the bq27545-G1 evaluation software or by data flash block transfers. These locations should be optimized and/or fixed during the development and manufacture processes. They become part of a golden image file and can then be written to multiple battery packs. Once established, the values generally remain unchanged during end-equipment operation.

To access data flash locations individually, the block containing the desired data flash location(s) must be transferred to the command register locations, where they can be read to the system or changed directly. This is accomplished by sending the set-up command *BlockDataControl()* (0x61) with data 0x00. Up to 32 bytes of data can be read directly from the *BlockData()* (0x40...0x5f), externally altered, then rewritten to the *BlockData()* command space. Alternatively, specific locations can be read, altered, and rewritten if their corresponding offsets are used to index into the *BlockData()* command space. Finally, the data residing in the command space is transferred to data flash, once the correct checksum for the whole block is written to *BlockDataChecksum()* (0x60).

Occasionally, a data flash CLASS will be larger than the 32-byte block size. In this case, the *DataFlashBlock()* command is used to designate which 32-byte block the desired locations reside in. The correct command address is then given by $0x40 + \text{offset modulo } 32$. For example, to access **Terminate Voltage** in the *Gas Gauging* class, *DataFlashClass()* is issued 80 (0x50) to set the class. Because the offset is 67, it must reside in the third 32-byte block. Hence, *DataFlashBlock()* is issued 0x02 to set the block offset, and the offset used to index into the *BlockData()* memory area is $0x40 + 67 \text{ modulo } 32 = 0x40 + 16 = 0x40 + 0x03 = 0x43$.

Reading and writing subclass data are block operations up to 32 bytes in length. If during a write the data length exceeds the maximum block size, then the data is ignored.

None of the data written to memory are bounded by the bq27545-G1—the values are not rejected by the fuel gauge. Writing an incorrect value may result in hardware failure due to firmware program interpretation of the invalid data. The written data is persistent, so a power-on reset does not resolve the fault.

9.5.4.2 Manufacturer Information Blocks

The bq27545-G1 contains 64 bytes of user programmable data flash storage: **Manufacturer Info Block A** and **Manufacturer Info Block B**. The method for accessing these memory locations is slightly different, depending on whether the device is in UNSEALED or SEALED modes.

When in UNSEALED mode and when 0x00 has been written to *BlockDataControl()*, accessing the Manufacturer Info Blocks is identical to accessing general data flash locations. First, a *DataFlashClass()* command is used to set the subclass, then a *DataFlashBlock()* command sets the offset for the first data flash address within the subclass. The *BlockData()* command codes contain the referenced data flash data. When writing the data flash, a checksum is expected to be received by *BlockDataChecksum()*. Only when the checksum is received and verified is the data actually written to data flash.

As an example, the data flash location for **Manufacturer Info Block B** is defined as having a subclass = 58 and an Offset = 32 through 63 (32 byte block). The specification of Class = System Data is not needed to address **Manufacturer Info Block B**, but is used instead for grouping purposes when viewing data flash info in the bq27545-G1 evaluation software.

When in SEALED mode or when 0x01 *BlockDataControl()* does not contain 0x00, data flash is no longer available in the manner used in UNSEALED mode. Rather than issuing subclass information, a designated Manufacturer Information Block is selected with the *DataFlashBlock()* command. Issuing a 0x01 or 0x02 with this command causes the corresponding information block (A or B respectively) to be transferred to the command space 0x40...0x5f for editing or reading by the system. Upon successful writing of checksum information to *BlockDataChecksum()*, the modified block is returned to data flash. **Note: Manufacturer Info Block A** is read-only when in SEALED mode.

9.5.5 Access Modes

The bq27545-G1 provides three security modes (FULL ACCESS, UNSEALED, and SEALED) that control data flash access permissions. *Data Flash* refers to those data flash locations, [Table 16](#), that are accessible to the user. *Manufacture Information* refers to the two 32-byte blocks.

Table 16. Data Flash Access

SECURITY MODE	DATA FLASH	MANUFACTURER INFORMATION
FULL ACCESS	R/W	R/W
UNSEALED	R/W	R/W
SEALED	None	R (A); R/W (B)

Although FULL ACCESS and UNSEALED modes appear identical, only FULL ACCESS mode allows the bq27545-G1 to write access-mode transition keys stored in the Security class.

9.5.6 Sealing and Unsealing Data Flash

The bq27545-G1 implements a key-access scheme to transition between SEALED, UNSEALED, and FULL-ACCESS modes. Each transition requires that a unique set of two keys be sent to the bq27545-G1 through the *Control()* control command. The keys must be sent consecutively, with no other data being written to the *Control()* register in between. To avoid conflict, the keys must be different from the codes presented in the *CNTL DATA* column of [Table 12](#) subcommands.

When in SEALED mode the [SS] bit of CONTROL_STATUS is set, but when the UNSEAL keys are correctly received by the bq27545-G1, the [SS] bit is cleared. When the full-access keys are correctly received the CONTROL_STATUS [FAS] bit is cleared.

Both **Unseal Key** and **Full-Access Key** have two words and are stored in data flash. The first word is Key 0 and the second word is Key 1. The order of the keys sent to bq27545-G1 are Key 1 followed by Key 0. The order of the bytes for each key entered through the *Control()* command is the reverse of what is read from the part. For an example, if the Unseal Key is 0x56781234, key 1 is 0x1234 and key 0 is 0x5678. Then *Control()* should supply 0x3412 and 0x7856 to unseal the part. The **Unseal Key** and the **Full-Access Key** can only be updated when in FULL-ACCESS mode.

9.5.7 Data Flash Summary

[Table 18](#) summarizes the data flash locations available to the user, including their default, minimum, and maximum values.

Table 17. Data Flash Summary

Class	Subclass ID	Subclass	Offset	Name	Data Type	Min Value	Max Value	Default Value	Units (EVSU Units)*
Configuration	2	Safety	0	OT Chg	I2	0	1200	550	0.1°C
Configuration	2	Safety	2	OT Chg Time	U1	0	60	2	s
Configuration	2	Safety	3	OT Chg Recovery	I2	0	1200	500	0.1°C
Configuration	2	Safety	5	OT Dsg	I2	0	1200	600	0.1°C
Configuration	2	Safety	7	OT Dsg Time	U1	0	60	2	s
Configuration	2	Safety	8	OT Dsg Recovery	I2	0	1200	550	0.1°C
Configuration	32	Charge Inhibit Cfg	0	Chg Inhibit Temp Low	I2	-400	1200	0	0.1°C
Configuration	32	Charge Inhibit Cfg	2	Chg Inhibit Temp High	I2	-400	1200	450	0.1°C
Configuration	32	Charge Inhibit Cfg	4	Temp Hys	I2	0	100	50	0.1°C
Configuration	34	Charge	0	Charging Voltage	I2	0	4600	4200	mV

Table 17. Data Flash Summary (continued)

Class	Subclass ID	Subclass	Offset	Name	Data Type	Min Value	Max Value	Default Value	Units (EVSU Units)*
Configuration	36	Charge Termination	0	Taper Current	I2	0	1000	100	mA
Configuration	36	Charge Termination	2	Min Taper Capacity	I2	0	1000	25	mAh
Configuration	36	Charge Termination	4	Taper Voltage	I2	0	1000	100	mV
Configuration	36	Charge Termination	6	Current Taper Window	U1	0	60	40	s
Configuration	36	Charge Termination	7	TCA Set %	I1	-1	100	99	%
Configuration	36	Charge Termination	8	TCA Clear %	I1	-1	100	95	%
Configuration	36	Charge Termination	9	FC Set %	I1	-1	100	-1	%
Configuration	36	Charge Termination	10	FC Clear %	I1	-1	100	98	%
Configuration	36	Charge Termination	11	DODatEOC Delta T	I2	0	1000	50	0.1°C
Configuration	48	Data	0	Rem Cap Alarm	I2	0	700	100	mA
Configuration	48	Data	8	Initial Standby	I1	-256	0	-10	mA
Configuration	48	Data	9	Initial MaxLoad	I2	-32767	0	-500	mA
Configuration	48	Data	17	Cycle Count	U2	0	65535	0	
Configuration	48	Data	19	CC Threshold	I2	100	32767	900	mAh
Configuration	48	Data	23	Design Capacity	I2	0	32767	1000	mAh
Configuration	48	Data	25	Design Energy	I2	0	32767	5400	mWh
Configuration	48	Data	27	SOH Load I	I2	-32767	0	-400	mA
Configuration	48	Data	29	TDD SOH Percent	I1	0	100	80	%
Configuration	48	Data	40	ISD Current	I2	0	32767	10	HourRate
Configuration	48	Data	42	ISD I Filter	U1	0	255	127	
Configuration	48	Data	43	Min ISD Time	U1	0	255	7	Hour
Configuration	48	Data	44	Design Energy Scale	U1	0	255	1	
Configuration	48	Data	45	Device Name	S11	x	x	bq27545-G1	—
Configuration	49	Discharge	0	SOC1 Set Threshold	U2	0	65535	150	mAh
Configuration	49	Discharge	2	SOC1 Clear Threshold	U2	0	65535	175	mAh
Configuration	49	Discharge	4	SOCF Set Threshold	U2	0	65535	75	mAh
Configuration	49	Discharge	6	SOCF Clear Threshold	U2	0	65535	100	mAh
Configuration	49	Discharge	9	BL Set Volt Threshold	I2	0	16800	2500	mV
Configuration	49	Discharge	11	BL Set Volt Time	U1	0	60	2	s
Configuration	49	Discharge	12	BL Clear Volt Threshold	I2	0000	16800	2600	mV
Configuration	49	Discharge	14	BH Set Volt Threshold	I2	0	16800	4500	mV
Configuration	49	Discharge	16	BH Volt Time	U1	0	60	2	s
Configuration	49	Discharge	17	BH Clear Volt Threshold	I2	0000	16800	4400	mV
Configuration	56	Manufacturer Data	0	Pack Lot Code	H2	0x0	0xffff	0x0	—
Configuration	56	Manufacturer Data	2	PCB Lot Code	H2	0x0	0xffff	0x0	—
Configuration	56	Manufacturer Data	4	Firmware Version	H2	0x0	0xffff	0x0	—
Configuration	56	Manufacturer Data	6	Hardware Revision	H2	0x0	0xffff	0x0	—
Configuration	56	Manufacturer Data	8	Cell Revision	H2	0x0	0xffff	0x0	—
Configuration	56	Manufacturer Data	10	DF Config Version	H2	0x0	0xffff	0x0	—
Configuration	57	Integrity Data	6	Static Chem DF Checksum	H2	0x0	0x7fff	0x0	
Configuration	59	Lifetime Data	0	Lifetime Max Temp	I2	0	1400	0	0.1°C
Configuration	59	Lifetime Data	2	Lifetime Min Temp	I2	-600	1400	500	0.1°C
Configuration	59	Lifetime Data	4	Lifetime Max Pack Voltage	I2	0	32767	2800	mV
Configuration	59	Lifetime Data	6	Lifetime Min Pack Voltage	I2	0	32767	4200	mV
Configuration	59	Lifetime Data	8	Lifetime Max Chg Current	I2	-32767	32767	0	mA
Configuration	59	Lifetime Data	10	Lifetime Max Dsg Current	I2	-32767	32767	0	mA
Configuration	60	Lifetime Temp Samples	0	LT Flash Cnt	U2	0	65535	0	
Configuration	64	Registers	0	Pack Configuration	H2	0x0	0xffff	0x1177	
Configuration	64	Registers	2	Pack Configuration B	H1	0x0	0xff	0xa7	
Configuration	64	Registers	3	Pack Configuration C	H1	0x0	0xff	0x18	
Configuration	66	Lifetime Resolution	0	LT Temp Res	U1	0	255	10	Num
Configuration	66	Lifetime Resolution	1	LT V Res	U1	0	255	25	Num
Configuration	66	Lifetime Resolution	2	LT Cur Res	U1	0	255	100	Num
Configuration	66	Lifetime Resolution	3	LT Update Time	U2	0	65535	60	Num
Configuration	68	Power	0	Flash Update OK Voltage	I2	0	4200	2800	mV

Table 17. Data Flash Summary (continued)

Class	Subclass ID	Subclass	Offset	Name	Data Type	Min Value	Max Value	Default Value	Units (EVSW Units)*
Configuration	68	Power	2	Sleep Current	I2	0	100	10	mA
Configuration	68	Power	11	Hibernate I	U2	0	700	8	mA
Configuration	68	Power	13	Hibernate V	U2	2400	3000	2550	mV
Configuration	68	Power	15	FS Wait	U1	0	255	0	s
System Data	58	Manufacturer Info	0–31	Block A 0–31	H1	0x0	0xff	0x0	—
System Data	58	Manufacturer Info	32–63	Block B 0–31	H1	0x0	0xff	0x0	—
Gas Gauging	80	IT Cfg	0	Load Select	U1	0	255	1	
Gas Gauging	80	IT Cfg	1	Load Mode	U1	0	255	0	
Gas Gauging	80	IT Cfg	21	Max Res Factor	U1	0	255	15	
Gas Gauging	80	IT Cfg	22	Min Res Factor	U1	0	255	5	
Gas Gauging	80	IT Cfg	25	Ra Filter	U2	0	1000	800	
Gas Gauging	80	IT Cfg	67	Terminate Voltage	I2	2800	3700	3000	mV
Gas Gauging	80	IT Cfg	69	Term V Delta	I2	0	4200	200	mV
Gas Gauging	80	IT Cfg	72	ResRelax Time	U2	0	65534	500	s
Gas Gauging	80	IT Cfg	76	User Rate-mA	I2	2000	9000	0	mA
Gas Gauging	80	IT Cfg	78	User Rate-Pwr	I2	3000	14000	0	mW/cW
Gas Gauging	80	IT Cfg	80	Reserve Cap-mAh	I2	0	9000	0	mA
Gas Gauging	80	IT Cfg	82	Reserve Energy	I2	0	14000	0	mWh/cWh
Gas Gauging	80	IT Cfg	86	Max Scale Back Grid	U1	0	15	4	
Gas Gauging	80	IT Cfg	87	Max DeltaV	U2	0	65535	200	mV
Gas Gauging	80	IT Cfg	89	Min DeltaV	U2	0	65535	0	mV
Gas Gauging	80	IT Cfg	91	Max Sim Rate	U1	0	255	1	C/rate
Gas Gauging	80	IT Cfg	92	Min Sim Rate	U1	0	255	20	C/rate
Gas Gauging	80	IT Cfg	93	Ra Max Delta	U2	0	65535	43	mΩ
Gas Gauging	80	IT Cfg	95	Qmax Max Delta %	U1	0	100	5	mAmpHour
Gas Gauging	80	IT Cfg	96	DeltaV Max Delta	U2	0	65535	10	mV
Gas Gauging	80	IT Cfg	102	Fast Scale Start SOC	U1	0	100	10	%
Gas Gauging	80	IT Cfg	103	Charge Hys V Shift	I2	0	2000	40	mV
Gas Gauging	81	Current Thresholds	0	Dsg Current Threshold	I2	0	2000	60	mA
Gas Gauging	81	Current Thresholds	2	Chg Current Threshold	I2	0	2000	75	mA
Gas Gauging	81	Current Thresholds	4	Quit Current	I2	0	1000	40	mA
Gas Gauging	81	Current Thresholds	6	Dsg Relax Time	U2	0	8191	60	s
Gas Gauging	81	Current Thresholds	8	Chg Relax Time	U1	0	255	60	s
Gas Gauging	81	Current Thresholds	9	Quit Relax Time	U1	0	63	1	s
Gas Gauging	81	Current Thresholds	10	Max IR Correct	U2	0	1000	400	mV
Gas Gauging	82	State	0	Qmax Cell 0	I2	0	32767	1000	mAh
Gas Gauging	82	State	2	Cycle Count	U2	0	65535	0	
Gas Gauging	82	State	4	Update Status	H1	0x0	0x6	0x0	
Gas Gauging	82	State	5	V at Chg Term	I2	0	5000	4200	mV
Gas Gauging	82	State	7	Avg I Last Run	I2	-32768	32767	-299	mA
Gas Gauging	82	State	9	Avg P Last Run	I2	-32768	32767	-1131	mA
Gas Gauging	82	State	11	Delta Voltage	I2	-32768	32767	2	mV
Gas Gauging	82	State	15	T Rise	I2	0	32767	20	Num
Gas Gauging	82	State	17	T Time Constant	I2	0	32767	1000	Num
OCV Table	83	OCV Table	0	Chem ID	H2	0	FFFF	0128	num
Ra Table	88	R_a0	0	Cell0 R_a flag	H2	0x0	0x0	0xff55	—
Ra Table	88	R_a0	2–31	Cell0 R_a 0–14	I2	183	183	407	2 ⁻¹⁰ Ω
Ra Table	89	R_a0x	0	xCell0 R_a flag	H2	0xffff	0xffff	0xffff	—
Ra Table	89	R_a0x	2–31	xCell0 R_a 0–14	I2	183	183	407	2 ⁻¹⁰ Ω
Calibration	104	Data	0	CC Gain	F4	1.0e-1	4.0e+1	0.4768	
Calibration	104	Data	4	CC Delta	F4	2.9826e+4	1.193046e+6	567744.56	
Calibration	104	Data	8	CC Offset	I2	-32768	32767	-1200	mA
Calibration	104	Data	10	Board Offset	I1	-128	127	0	μAmp
Calibration	104	Data	11	Int Temp Offset	I1	-128	127	0	

Table 17. Data Flash Summary (continued)

Class	Subclass ID	Subclass	Offset	Name	Data Type	Min Value	Max Value	Default Value	Units (EVSW Units)*
Calibration	104	Data	12	Ext Temp Offset	I1	-128	127	0	
Calibration	104	Data	13	Pack V Offset	I1	-128	127	0	
Calibration	107	Current	1	Deadband	U1	0	255	5	mA
Security	112	Codes	0	Sealed to Unsealed	H4	0x0	0xffffffff	0x36720414	—
Security	112	Codes	4	Unsealed to Full	H4	0x0	0xffffffff	0xffffffff	—
Security	112	Codes	8	Authen Key3	H4	0x0	0xffffffff	0x01234567	—
Security	112	Codes	12	Authen Key2	H4	0x0	0xffffffff	0x89abcdef	—
Security	112	Codes	16	Authen Key1	H4	0x0	0xffffffff	0xfedcba98	—
Security	112	Codes	20	Authen Key0	H4	0x0	0xffffffff	0x76543210	—

Table 18. Data Flash to EVSW Conversion

Class	Subclass ID	Subclass	Offset	Name	Data Type	Data Flash Default	Data Flash Unit	EVSW Default	EVSW Unit	Data Flash (DF) to EVSW Conversion
Gas Gauging	80	IT Cfg	78	User Rate-Pwr	I2	0	cW/10W	0	mW/cW	DF x 10
Gas Gauging	80	IT Cfg	82	Reserve Energy	I2	0	cWh/10cWh	0	mWh/cW	DF x 10
Calibration	104	Data	0	CC Gain	F4	0.47095	Num	10.124	mΩ	4.768/DF
Calibration	104	Data	4	CC Delta	F4	5.595e5	Num	10.147	mΩ	5677445/DF
Calibration	104	Data	8	CC Offset	I2	-1200	Num	-0.576	mV	DF x 0.0048
Calibration	104	Data	10	Board Offset	I1	0	Num	0	μV	DF x 0.0075

9.6 Register Maps

9.6.1 Pack Configuration Register

Some bq27545-G1 pins are configured through the **Pack Configuration** data flash register, as indicated in [Table 19](#). This register is programmed/read through the methods described in [Accessing the Data Flash](#). The register is located at Subclass = 64, offset = 0.

Table 19. Pack Configuration Bit Definition

	bit7	bit6	bit5	bit4	bit3	bit2	bit1	bit0
High Byte	RESCAP	CALEN	INTPOL	INTSEL	RSVD	IWAKE	RSNS1	RSNS0
Default =	0	0	0	1	0	0	0	1
	0x11							
Low Byte	GNDSEL	RFACTSTEP	SLEEP	RMFCC	SE_PU	SE_POL	SE_EN	TEMPS
Default =	0	1	1	1	0	1	1	1
	0x77							

RESCAP = No-load rate of compensation is applied to the reserve capacity calculation. True when set.

CALEN = Calibration mode is enabled.

INTPOL = Polarity for Interrupt pin. (See [INTERRUPT Mode](#).)

INTSEL = Interrupt Pin select: 0 = SE pin, 1 = HDQ pin. (See [INTERRUPT Mode](#).)

RSVD = Reserved. Must be 0.

IWAKE/RSNS1/RSNS0 = These bits configure the current wake function (See [Wake-Up Comparator](#)).

GNDSEL = The ADC ground select control. The V_{SS} (pins C1, C2) is selected as ground reference when the bit is clear. Pin A1 is selected when the bit is set.

RFACTSTEP = Enables Ra step up/down to Max/Min Res Factor before disabling Ra updates.

SLEEP = The fuel gauge can enter sleep, if operating conditions allow. True when set. (See [SLEEP Mode](#).)

RMFCC = RM is updated with the value from FCC, on valid charge termination. True when set. (See [Detection Charge Termination](#).)

SE_PU = pullup enable for SE pin. True when set (push-pull). (See [SHUTDOWN Mode](#).)

- SE_POL = Polarity bit for SE pin. SE is active high when set (makes SE high when gauge is ready for shutdown). (See [SHUTDOWN Mode](#).)
- SE_EN = Indicates if set the shutdown feature is enabled. True when set. (See [SHUTDOWN Mode](#).)
- TEMPS = Selects external thermistor for Temperature() measurements. True when set. (See [Temperature Measurement and the TS Input](#).)

9.6.2 Pack Configuration B Register

Some bq27545-G1 pins are configured through the **Pack Configuration B** data flash register, as indicated in [Table 20](#). This register is programmed/read through the methods described in [Accessing the Data Flash](#). The register is located at Subclass = 64, offset = 2.

Table 20. Pack Configuration B Bit Definition

	bit7	bit6	bit5	bit4	bit3	bit2	bit1	bit0
	ChgDoD EoC	SE_TDD	VconsEN	SE_ISD	RSVD	LFPRelax	DoDWT	FConvEn
Default =	1	0	1	0	0	1	1	1
0x67								

- ChgDoDEoC = Enable DoD at EoC recalculation during charging only. True when set. Default setting is recommended.
- SE_TDD = Enable Tab Disconnection Detection. True when set. (See [Tab Disconnection Detection](#).)
- VconsEN = Enable voltage consistency check. True when set. Default setting is recommended.
- SE_ISD = Enable Internal Short Detection. True when set. (See [Internal Short Detection](#).)
- RSVD = Reserved. Must be 0
- LFPRelax = Enable LiFePO4 long RELAX mode. True when set.
- DoDWT = Enable DoD weighting feature of gauging algorithm. This feature can improve accuracy during RELAX in a flat portion of the voltage profile, especially when using LiFePO4 chemistry. True when set.
- FConvEn = Enable fast convergence algorithm. Default setting is recommended. (See [Fast Resistance Scaling](#).)

9.6.3 Pack Configuration C Register

Some bq27545-G1 algorithm settings are configured through the **Pack Configuration C** data flash register, as indicated in [Table 21](#). This register is programmed/read through the methods described in [Accessing the Data Flash](#). The register is located at Subclass = 64, offset = 3.

Table 21. Pack Configuration C Bit Definition

	bit7	bit6	bit5	bit4	bit3	bit2	bit1	bit0
	RSVD	RSVD	RelaxRC JumpOK	SmoothEn	SleepWk Chg	RSVD	RSVD	RSVD
Default =	0	0	0	1	1	0	0	0
0x18								

- RSVD = Reserved. Must be 0.
- RelaxRCJumpOK = Allow SOC to change due to temperature change during relaxation when SOC smoothing algorithm is enabled. True when set.
- SmoothEn = Enable SOC smoothing algorithm. True when set. (See [StateOfCharge\(\) Smoothing](#).)
- SleepWkChg = Enables compensation for the passed charge missed when waking from SLEEP mode.

10 Application and Implementation

NOTE

Information in the following applications sections is not part of the TI component specification, and TI does not warrant its accuracy or completeness. TI's customers are responsible for determining suitability of components for their purposes. Customers should validate and test their design implementation to confirm system functionality.

10.1 Application Information

The bq27545-G1 measures the cell voltage, temperature, and current to determine battery SOC based on Impedance Track algorithm (see the *Theory and Implementation of Impedance Track Battery Fuel-Gauging Algorithm Application Note [SLUA450]* for more information). The bq27545-G1 monitors charge and discharge activity by sensing the voltage across a small-value resistor (5 mΩ to 20 mΩ typical.) between the SRP and SRN pins and in series with the cell. By integrating charge passing through the battery, the battery's SOC is adjusted during battery charge or discharge.

10.2 Typical Application

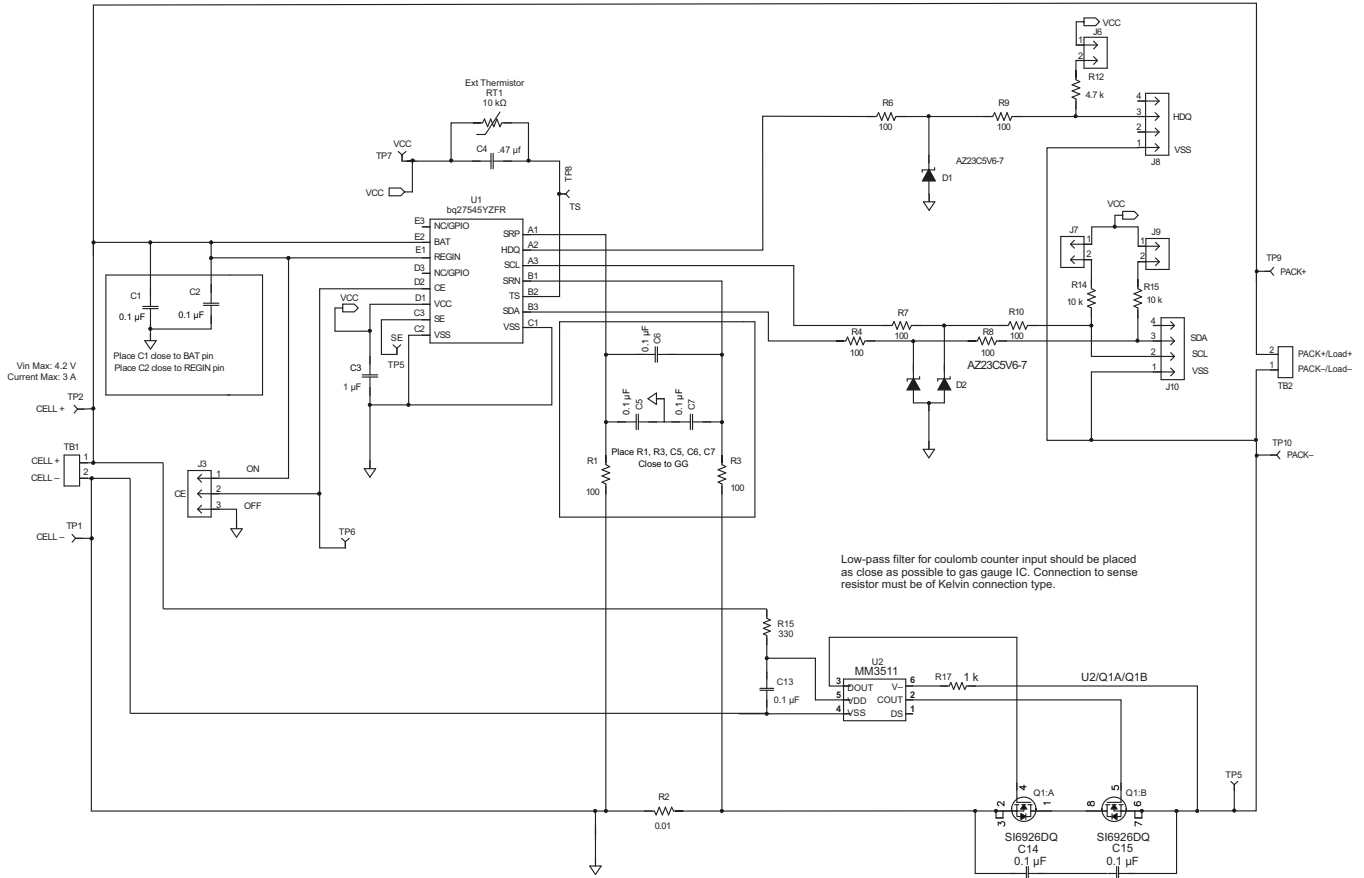

R7, R8, and R9 are optional pulldown resistors if pullup resistors are applied.

Figure 9. Reference Schematic

Typical Application (continued)

10.2.1 Design Requirements

Several key parameters must be updated to align with a given application's battery characteristics. For highest accuracy gauging, it is important to follow-up this initial configuration with a learning cycle to optimize resistance and maximum chemical capacity (Qmax) values before sealing and shipping systems to the field. Successful and accurate configuration of the fuel gauge for a target application can be used as the basis for creating a *golden file* that can be written to all gauges, assuming identical pack design and Li-Ion cell origin (chemistry, lot, and so on). Calibration data is included as part of this golden file to cut down on system production time. If using this method, TI recommends averaging the voltage and current measurement calibration data from a large sample size and use these in the golden file. [Table 22](#) shows the items that should be configured to achieve reliable protection and accurate gauging with minimal initial configuration.

Table 22. Key Data Flash Parameters for Configuration

NAME	DEFAULT	UNIT	RECOMMENDED SETTING
Design Capacity	1000	mAh	Set based on the nominal pack capacity as interpreted from the cell manufacturer's data sheet. If multiple parallel cells are used, should be set to N x Cell Capacity.
Design Energy Scale	1	—	Set to 10 to convert all power values to cWh or to 1 for mWh. Design Energy is divided by this value.
CC Threshold	900	mAh	Set to 90% of configured Design Capacity .
Chem ID	0100	hex	Should be configured using TI-supplied Battery Management Studio (bqStudio) software. Default open-circuit voltage and resistance tables are also updated in conjunction with this step. Do not attempt to manually update reported Device Chemistry as this does not change all chemistry information. Always update chemistry using the bqStudio software tool.
Load Mode	1	—	Set to applicable load model, 0 for constant current or 1 for constant power.
Load Select	1	—	Set to load profile which most closely matches typical system load.
Qmax Cell 0	1000	mAh	Set to initial configured value for Design Capacity. The gauge will update this parameter automatically after the optimization cycle and for every regular Qmax update thereafter.
Terminate Voltage	3200	mV	Set to empty point reference of battery based on system needs. Typical is from 3000 mV to 3200 mV.
Ra Max Delta	44	mΩ	Set to 15% of Cell0 R_a 4 resistance after an optimization cycle is completed.
Charging Voltage	4200	mV	Set based on nominal charge voltage for the battery in normal conditions (25°C, and so on). Used as the reference point for offsetting by Taper Voltage for full charge termination detection.
Taper Current	100	mA	Set to the nominal taper current of the charger + taper current tolerance to ensure that the gauge will reliably detect charge termination.
Taper Voltage	100	mV	Sets the voltage window for qualifying full charge termination. Can be set tighter to avoid or wider to ensure possibility of reporting 100% SOC in outer JEITA temperature ranges that use derated charging voltage.
Dsg Current Threshold	60	mA	Sets threshold for gauge detecting battery discharge. Should be set lower than minimal system load expected in the application and higher than Quit Current .
Chg Current Threshold	75	mA	Sets the threshold for detecting battery charge. Can be set higher or lower depending on typical trickle charge current used. Also should be set higher than Quit Current .
Quit Current	40	mA	Sets threshold for gauge detecting battery relaxation. Can be set higher or lower depending on typical standby current and exhibited in the end system.
Avg I Last Run	-299	mA	Current profile used in capacity simulations at onset of discharge or at all times if Load Select = 0. Should be set to nominal system load. Is automatically updated by the gauge every cycle.
Avg P Last Run	-1131	mW	Power profile used in capacity simulations at onset of discharge or at all times if Load Select = 0. Should be set to nominal system power. Is automatically updated by the gauge every cycle.
Sleep Current	15	mA	Sets the threshold at which the fuel gauge enters SLEEP mode. Take care in setting above typical standby currents else entry to SLEEP may be unintentionally blocked.

Typical Application (continued)

Table 22. Key Data Flash Parameters for Configuration (continued)

NAME	DEFAULT	UNIT	RECOMMENDED SETTING
CC Gain	10	mΩ	Calibrate this parameter using TI-supplied bqStudio software and calibration procedure in the TRM. Determines conversion of coulomb counter measured sense resistor voltage to current.
CC Delta	10	mΩ	Calibrate this parameter using TI-supplied bqStudio software and calibration procedure in the TRM. Determines conversion of coulomb counter measured sense resistor voltage to passed charge.
CC Offset	-1418	Counts	Calibrate this parameter using TI-supplied bqStudio software and calibration procedure in the TRM. Determines native offset of coulomb counter hardware that should be removed from conversions.
Board Offset	0	Counts	Calibrate this parameter using TI-supplied bqStudio software and calibration procedure in the TRM. Determines native offset of the printed-circuit-board parasitics that should be removed from conversions.

10.2.2 Detailed Design Procedure

10.2.2.1 BAT Voltage Sense Input

A ceramic capacitor at the input to the BAT pin is used to bypass AC voltage ripple to ground, greatly reducing its influence on battery voltage measurements. It proves most effective in applications with load profiles that exhibit high-frequency current pulses (that is, cell phones), but is recommended for use in all applications to reduce noise on this sensitive high-impedance measurement node.

10.2.2.2 SRP and SRN Current Sense Inputs

The filter network at the input to the coulomb counter is intended to improve differential mode rejection of voltage measured across the sense resistor. These components should be placed as close as possible to the coulomb counter inputs and the routing of the differential traces length-matched to best minimize impedance mismatch-induced measurement errors.

10.2.2.3 Sense Resistor Selection

Any variation encountered in the resistance present between the SRP and SRN pins of the fuel gauge will affect the resulting differential voltage and derived current it senses. As such, TI recommends selecting a sense resistor with minimal tolerance and temperature coefficient of resistance (TCR) characteristics. The standard recommendation based on best compromise between performance and price is a 1% tolerance, 100-ppm drift sense resistor with a 1-W power rating.

10.2.2.4 TS Temperature Sense Input

Similar to the BAT pin, a ceramic decoupling capacitor for the TS pin is used to bypass AC voltage ripple away from the high-impedance ADC input, minimizing measurement error. Another helpful advantage is that the capacitor provides additional ESD protection because the TS input to system may be accessible in systems that use removable battery packs. It should be placed as close as possible to the respective input pin for optimal filtering performance.

10.2.2.5 Thermistor Selection

The fuel gauge temperature sensing circuitry is designed to work with a negative temperature coefficient-type (NTC) thermistor with a characteristic 10-kΩ resistance at room temperature (25°C). The default curve-fitting coefficients configured in the fuel gauge specifically assume a 103AT-2 type thermistor profile and so that is the default recommendation for thermistor selection purposes. Moving to a separate thermistor resistance profile (for example, JT-2 or others) requires an update to the default thermistor coefficients in data flash to ensure highest accuracy temperature measurement performance.

10.2.2.6 REGIN Power Supply Input Filtering

A ceramic capacitor is placed at the input to the fuel gauge internal LDO to increase power supply rejection (PSR) and improve effective line regulation. It ensures that voltage ripple is rejected to ground instead of coupling into the internal supply rails of the fuel gauge.

10.2.2.7 V_{CC} LDO Output Filtering

A ceramic capacitor is also needed at the output of the internal LDO to provide a current reservoir for fuel gauge load peaks during high peripheral utilization. It acts to stabilize the regulator output and reduce core voltage ripple inside of the fuel gauge.

10.2.3 Application Curves

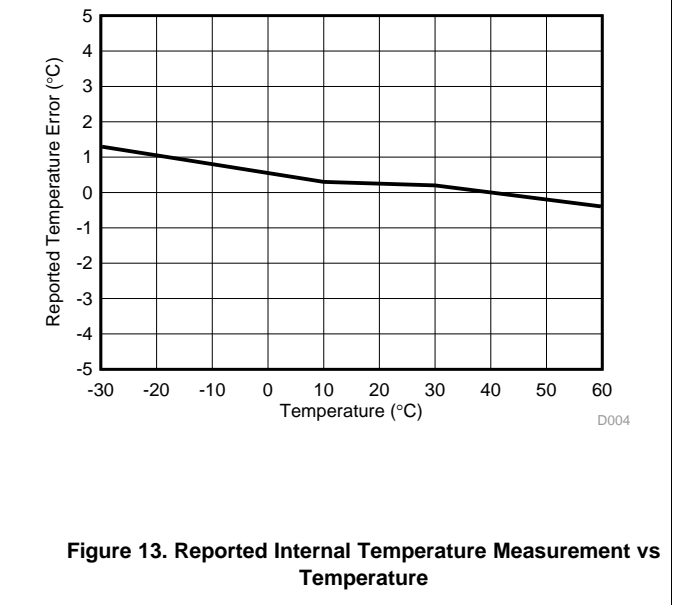
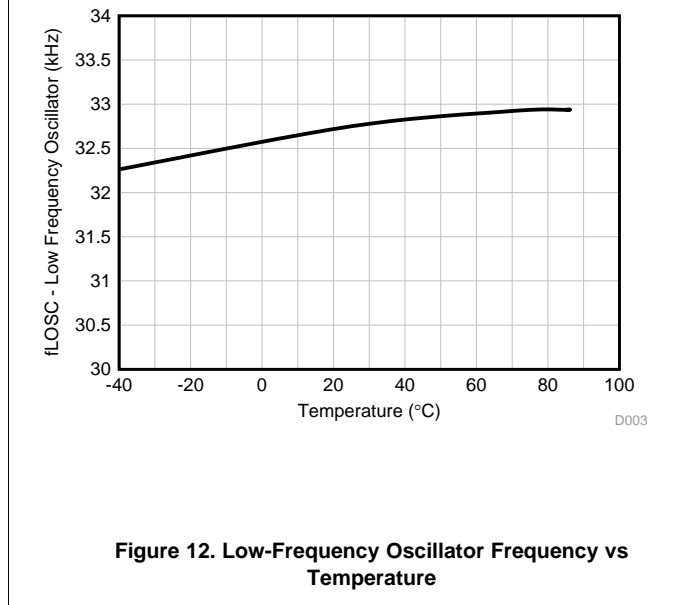
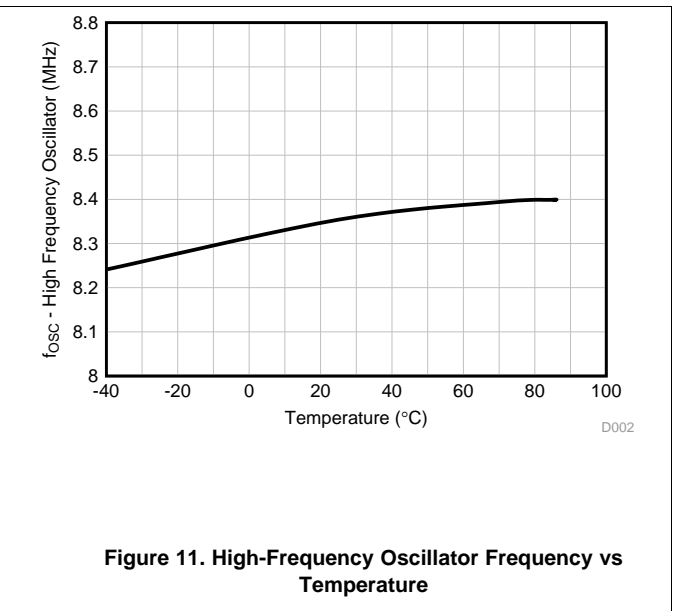
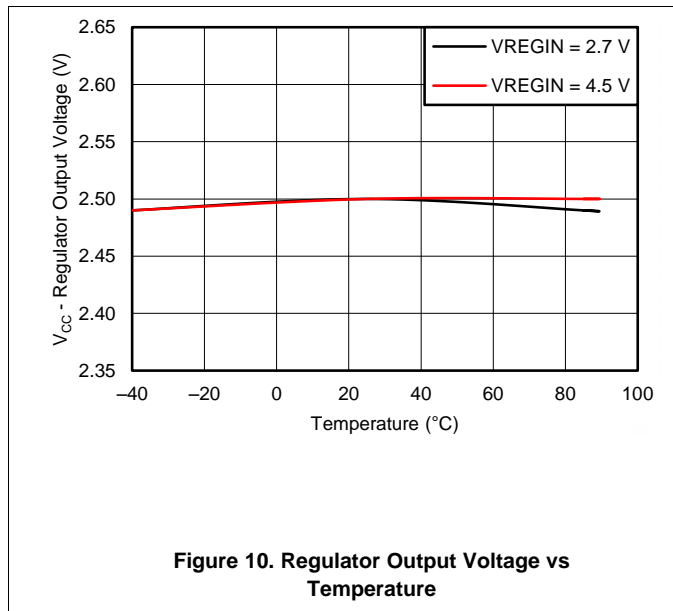

11 Power Supply Recommendations

11.1 Power Supply Decoupling

Both the REGIN input pin and the V_{CC} output pin require low equivalent series resistance (ESR) ceramic capacitors placed as close as possible to the respective pins to optimize ripple rejection and provide a stable and dependable power rail that is resilient to line transients. A 0.1- μ F capacitor at the REGIN and a 1- μ F capacitor at V_{CC} will suffice for satisfactory device performance.

12 Layout

12.1 Layout Guidelines

12.1.1 Sense Resistor Connections

Kelvin connections at the sense resistor are as critical as those for the battery terminals. The differential traces should be connected at the inside of the sense resistor pads and not along the high-current trace path to prevent false increases to measured current that could result when measuring between the sum of the sense resistor and trace resistance between the tap points. In addition, the routing of these leads from the sense resistor to the input filter network and finally into the SRP and SRN pins must be as closely matched in length as possible or else additional measurement offset could occur. It is further recommended to add copper trace or pour-based "guard rings" around the perimeter of the filter network and coulomb counter inputs to shield these sensitive pins from radiated EMI into the sense nodes. This prevents differential voltage shifts that could be interpreted as real current change to the fuel gauge. All of the filter components must be placed as close as possible to the coulomb counter input pins.

12.1.2 Thermistor Connections

The thermistor sense input should include a ceramic bypass capacitor placed as close to the TS input pin as possible. The capacitor helps to filter measurements of any stray transients as the voltage bias circuit pulses periodically during temperature sensing windows.

12.1.3 High-Current and Low-Current Path Separation

NOTE

For best possible noise performance, it is important to separate the low-current and high-current loops to different areas of the board layout.

The fuel gauge and all support components should be situated on one side of the boards and tap off of the high-current loop (for measurement purposes) at the sense resistor. Routing the low-current ground around instead of under high-current traces will further help to improve noise rejection.

12.2 Layout Example

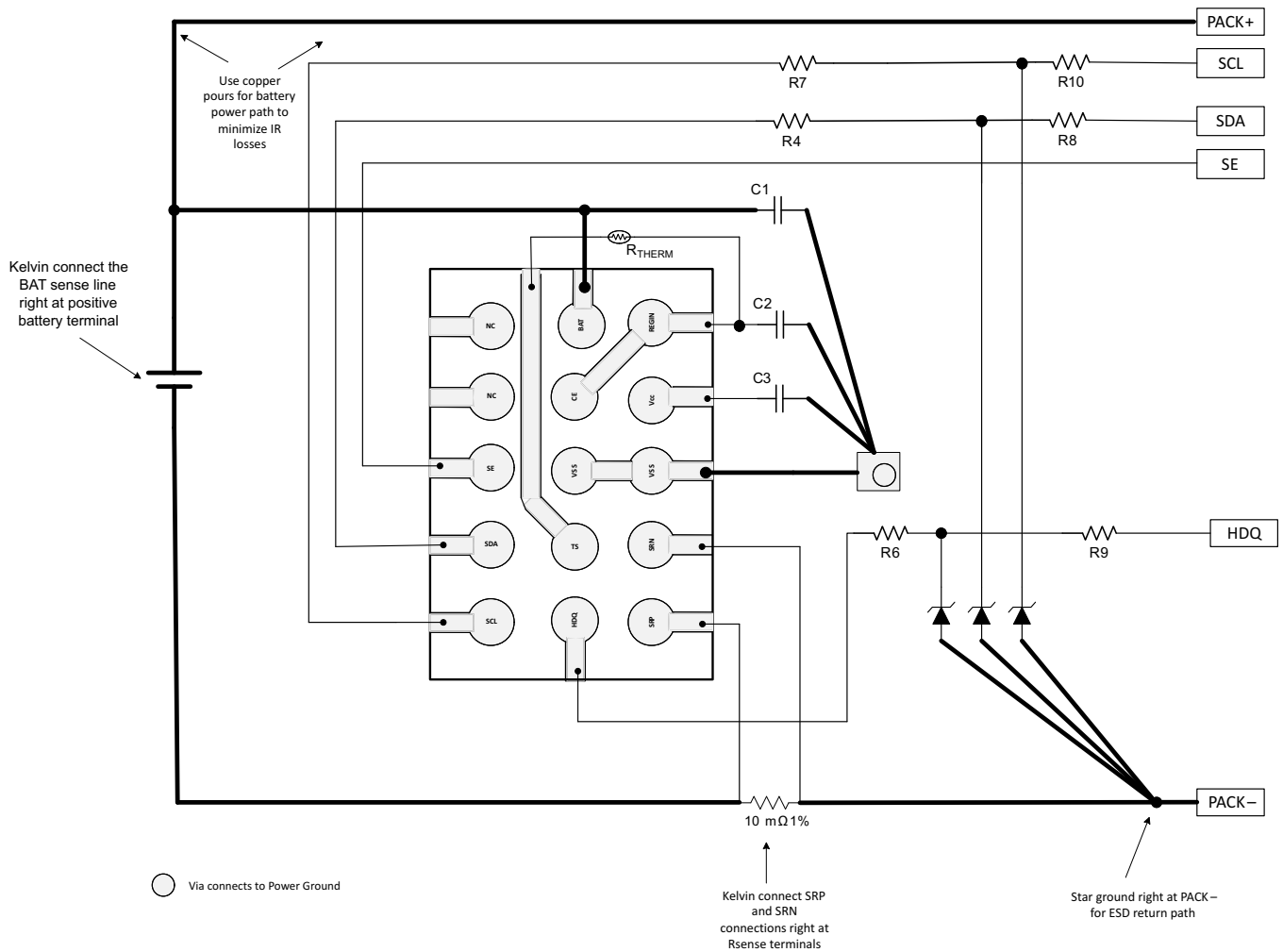

Figure 14. Layout Example

13 Device and Documentation Support

13.1 Documentation Support

13.1.1 Related Documentation

For related documentation see the following:

- *bq27545EVM Single-Cell Impedance Track™ Technology Evaluation Module* ([SLUU984](#))
- *Theory and Implementation of Impedance Track Battery Fuel-Gauging Algorithm* ([SLUA450](#))

13.2 Community Resources

The following links connect to TI community resources. Linked contents are provided "AS IS" by the respective contributors. They do not constitute TI specifications and do not necessarily reflect TI's views; see TI's [Terms of Use](#).

TI E2E™ Online Community *TI's Engineer-to-Engineer (E2E) Community*. Created to foster collaboration among engineers. At [e2e.ti.com](#), you can ask questions, share knowledge, explore ideas and help solve problems with fellow engineers.

Design Support *TI's Design Support* Quickly find helpful E2E forums along with design support tools and contact information for technical support.

13.3 Trademarks

Impedance Track, Nano-Free, E2E are trademarks of Texas Instruments.

I²C is a trademark of NXP Semiconductors, N.V.

All other trademarks are the property of their respective owners.

13.4 Electrostatic Discharge Caution



These devices have limited built-in ESD protection. The leads should be shorted together or the device placed in conductive foam during storage or handling to prevent electrostatic damage to the MOS gates.

13.5 Glossary

[SLYZ022](#) — *TI Glossary*.

This glossary lists and explains terms, acronyms, and definitions.

14 Mechanical, Packaging, and Orderable Information

The following pages include mechanical, packaging, and orderable information. This information is the most current data available for the designated devices. This data is subject to change without notice and revision of this document. For browser-based versions of this data sheet, refer to the left-hand navigation.

PACKAGING INFORMATION

Orderable Device	Status (1)	Package Type	Package Drawing	Pins	Package Qty	Eco Plan (2)	Lead/Ball Finish (6)	MSL Peak Temp (3)	Op Temp (°C)	Device Marking (4/5)	Samples
BQ27545YZFR-G1	NRND	DSBGA	YZF	15	3000	Green (RoHS & no Sb/Br)	SNAGCU	Level-1-260C-UNLIM	-40 to 85	BQ27545	
BQ27545YZFT-G1	NRND	DSBGA	YZF	15	250	Green (RoHS & no Sb/Br)	SNAGCU	Level-1-260C-UNLIM	-40 to 85	BQ27545	

(1) The marketing status values are defined as follows:

ACTIVE: Product device recommended for new designs.

LIFEBUY: TI has announced that the device will be discontinued, and a lifetime-buy period is in effect.

NRND: Not recommended for new designs. Device is in production to support existing customers, but TI does not recommend using this part in a new design.

PREVIEW: Device has been announced but is not in production. Samples may or may not be available.

OBSELETE: TI has discontinued the production of the device.

(2) Eco Plan - The planned eco-friendly classification: Pb-Free (RoHS), Pb-Free (RoHS Exempt), or Green (RoHS & no Sb/Br) - please check <http://www.ti.com/productcontent> for the latest availability information and additional product content details.

TBD: The Pb-Free/Green conversion plan has not been defined.

Pb-Free (RoHS): TI's terms "Lead-Free" or "Pb-Free" mean semiconductor products that are compatible with the current RoHS requirements for all 6 substances, including the requirement that lead not exceed 0.1% by weight in homogeneous materials. Where designed to be soldered at high temperatures, TI Pb-Free products are suitable for use in specified lead-free processes.

Pb-Free (RoHS Exempt): This component has a RoHS exemption for either 1) lead-based flip-chip solder bumps used between the die and package, or 2) lead-based die adhesive used between the die and leadframe. The component is otherwise considered Pb-Free (RoHS compatible) as defined above.

Green (RoHS & no Sb/Br): TI defines "Green" to mean Pb-Free (RoHS compatible), and free of Bromine (Br) and Antimony (Sb) based flame retardants (Br or Sb do not exceed 0.1% by weight in homogeneous material)

(3) MSL, Peak Temp. - The Moisture Sensitivity Level rating according to the JEDEC industry standard classifications, and peak solder temperature.

(4) There may be additional marking, which relates to the logo, the lot trace code information, or the environmental category on the device.

(5) Multiple Device Markings will be inside parentheses. Only one Device Marking contained in parentheses and separated by a "~" will appear on a device. If a line is indented then it is a continuation of the previous line and the two combined represent the entire Device Marking for that device.

(6) Lead/Ball Finish - Orderable Devices may have multiple material finish options. Finish options are separated by a vertical ruled line. Lead/Ball Finish values may wrap to two lines if the finish value exceeds the maximum column width.

Important Information and Disclaimer:The information provided on this page represents TI's knowledge and belief as of the date that it is provided. TI bases its knowledge and belief on information provided by third parties, and makes no representation or warranty as to the accuracy of such information. Efforts are underway to better integrate information from third parties. TI has taken and continues to take reasonable steps to provide representative and accurate information but may not have conducted destructive testing or chemical analysis on incoming materials and chemicals. TI and TI suppliers consider certain information to be proprietary, and thus CAS numbers and other limited information may not be available for release.

In no event shall TI's liability arising out of such information exceed the total purchase price of the TI part(s) at issue in this document sold by TI to Customer on an annual basis.

TAPE AND REEL INFORMATION

QUADRANT ASSIGNMENTS FOR PIN 1 ORIENTATION IN TAPE

*All dimensions are nominal

Device	Package Type	Package Drawing	Pins	SPQ	Reel Diameter (mm)	Reel Width W1 (mm)	A0 (mm)	B0 (mm)	K0 (mm)	P1 (mm)	W (mm)	Pin1 Quadrant
BQ27545YZFR-G1	DSBGA	YZF	15	3000	180.0	8.4	2.1	2.76	0.81	4.0	8.0	Q1
BQ27545YZFT-G1	DSBGA	YZF	15	250	180.0	8.4	2.1	2.76	0.81	4.0	8.0	Q1

TAPE AND REEL BOX DIMENSIONS

*All dimensions are nominal

Device	Package Type	Package Drawing	Pins	SPQ	Length (mm)	Width (mm)	Height (mm)
BQ27545YZFR-G1	DSBGA	YZF	15	3000	182.0	182.0	20.0
BQ27545YZFT-G1	DSBGA	YZF	15	250	182.0	182.0	20.0

YZF (R-XBGA-N15)

DIE-SIZE BALL GRID ARRAY

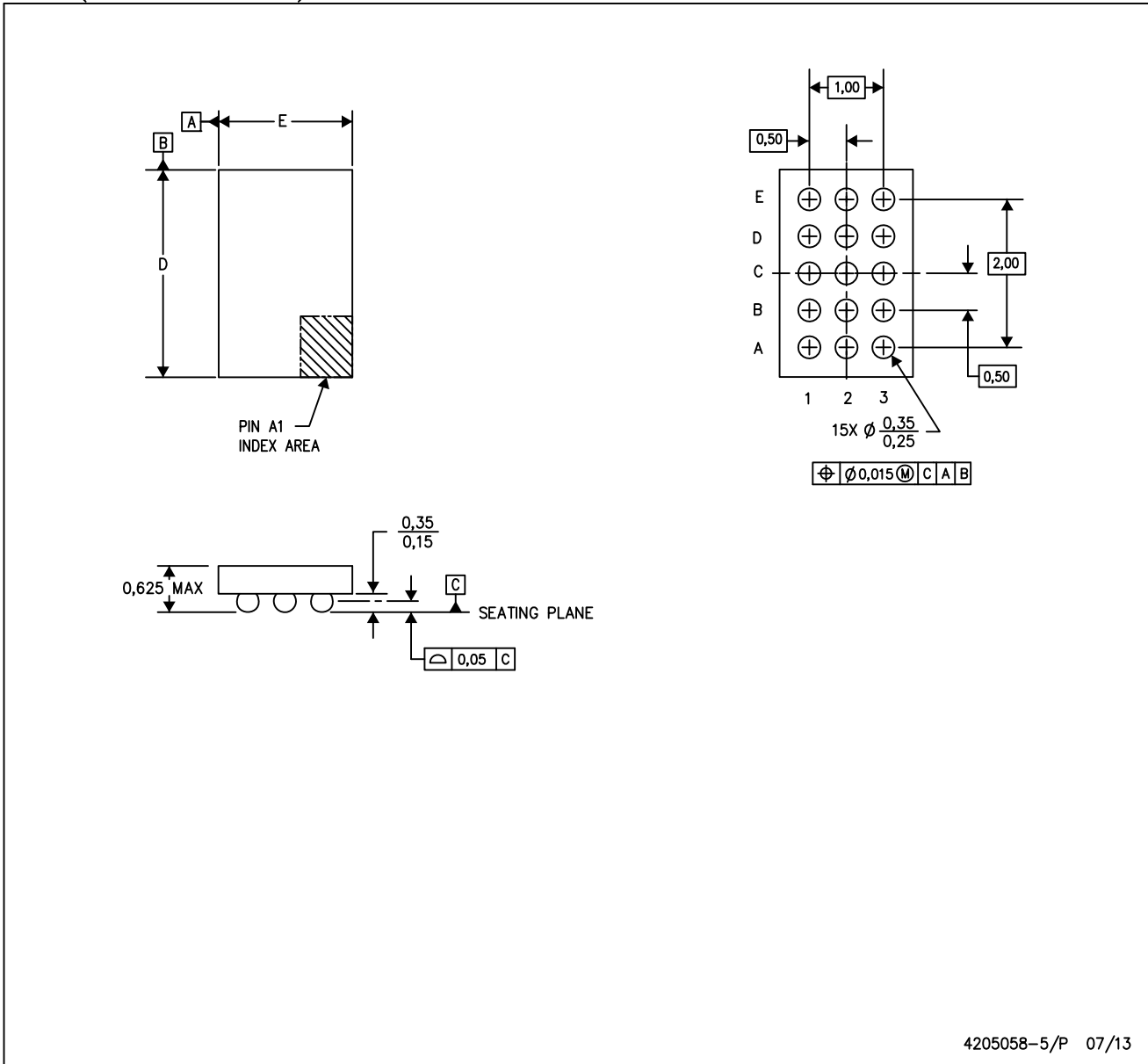

- NOTES: A. All linear dimensions are in millimeters. Dimensioning and tolerancing per ASME Y14.5M-1994.
 B. This drawing is subject to change without notice.
 C. NanoFree™ package configuration.

NanoFree is a trademark of Texas Instruments.

IMPORTANT NOTICE

Texas Instruments Incorporated and its subsidiaries (TI) reserve the right to make corrections, enhancements, improvements and other changes to its semiconductor products and services per JESD46, latest issue, and to discontinue any product or service per JESD48, latest issue. Buyers should obtain the latest relevant information before placing orders and should verify that such information is current and complete. All semiconductor products (also referred to herein as "components") are sold subject to TI's terms and conditions of sale supplied at the time of order acknowledgment.

TI warrants performance of its components to the specifications applicable at the time of sale, in accordance with the warranty in TI's terms and conditions of sale of semiconductor products. Testing and other quality control techniques are used to the extent TI deems necessary to support this warranty. Except where mandated by applicable law, testing of all parameters of each component is not necessarily performed.

TI assumes no liability for applications assistance or the design of Buyers' products. Buyers are responsible for their products and applications using TI components. To minimize the risks associated with Buyers' products and applications, Buyers should provide adequate design and operating safeguards.

TI does not warrant or represent that any license, either express or implied, is granted under any patent right, copyright, mask work right, or other intellectual property right relating to any combination, machine, or process in which TI components or services are used. Information published by TI regarding third-party products or services does not constitute a license to use such products or services or a warranty or endorsement thereof. Use of such information may require a license from a third party under the patents or other intellectual property of the third party, or a license from TI under the patents or other intellectual property of TI.

Reproduction of significant portions of TI information in TI data books or data sheets is permissible only if reproduction is without alteration and is accompanied by all associated warranties, conditions, limitations, and notices. TI is not responsible or liable for such altered documentation. Information of third parties may be subject to additional restrictions.

Resale of TI components or services with statements different from or beyond the parameters stated by TI for that component or service voids all express and any implied warranties for the associated TI component or service and is an unfair and deceptive business practice. TI is not responsible or liable for any such statements.

Buyer acknowledges and agrees that it is solely responsible for compliance with all legal, regulatory and safety-related requirements concerning its products, and any use of TI components in its applications, notwithstanding any applications-related information or support that may be provided by TI. Buyer represents and agrees that it has all the necessary expertise to create and implement safeguards which anticipate dangerous consequences of failures, monitor failures and their consequences, lessen the likelihood of failures that might cause harm and take appropriate remedial actions. Buyer will fully indemnify TI and its representatives against any damages arising out of the use of any TI components in safety-critical applications.

In some cases, TI components may be promoted specifically to facilitate safety-related applications. With such components, TI's goal is to help enable customers to design and create their own end-product solutions that meet applicable functional safety standards and requirements. Nonetheless, such components are subject to these terms.

No TI components are authorized for use in FDA Class III (or similar life-critical medical equipment) unless authorized officers of the parties have executed a special agreement specifically governing such use.

Only those TI components which TI has specifically designated as military grade or "enhanced plastic" are designed and intended for use in military/aerospace applications or environments. Buyer acknowledges and agrees that any military or aerospace use of TI components which have **not** been so designated is solely at the Buyer's risk, and that Buyer is solely responsible for compliance with all legal and regulatory requirements in connection with such use.

TI has specifically designated certain components as meeting ISO/TS16949 requirements, mainly for automotive use. In any case of use of non-designated products, TI will not be responsible for any failure to meet ISO/TS16949.

Products

Audio	www.ti.com/audio
Amplifiers	amplifier.ti.com
Data Converters	dataconverter.ti.com
DLP® Products	www.dlp.com
DSP	dsp.ti.com
Clocks and Timers	www.ti.com/clocks
Interface	interface.ti.com
Logic	logic.ti.com
Power Mgmt	power.ti.com
Microcontrollers	microcontroller.ti.com
RFID	www.ti-rfid.com
OMAP Applications Processors	www.ti.com/omap
Wireless Connectivity	www.ti.com/wirelessconnectivity

Applications

Automotive and Transportation	www.ti.com/automotive
Communications and Telecom	www.ti.com/communications
Computers and Peripherals	www.ti.com/computers
Consumer Electronics	www.ti.com/consumer-apps
Energy and Lighting	www.ti.com/energy
Industrial	www.ti.com/industrial
Medical	www.ti.com/medical
Security	www.ti.com/security
Space, Avionics and Defense	www.ti.com/space-avionics-defense
Video and Imaging	www.ti.com/video

TI E2E Community

e2e.ti.com