

# TPS62097 2-A High Efficiency Step-Down Converter with iDCS-Control, Forced PWM Mode and Selective Switching Frequency

## 1 Features

- iDCS-Control Topology
- Forced PWM or Power Save Mode
- Up to 97% Efficiency
- 2.5-V to 6.0-V Input Voltage
- 0.8-V to  $V_{IN}$  Adjustable Output Voltage
- 1.8-V and 3.3-V Fixed Output Voltage
- $\pm 1\%$  Output Voltage Accuracy
- Hiccup Short Circuit Protection
- Programmable Soft Startup
- Output Voltage Tracking
- Selectable Switching Frequency
- 100% Duty Cycle for Lowest Dropout
- Output Discharge
- Power Good Output
- Thermal Shutdown Protection
- $-40^{\circ}\text{C}$  to  $125^{\circ}\text{C}$  Operating Junction Temperature
- Available in 2-mm x 2-mm VQFN Package

## 2 Applications

- Industrial Applications
- Programmable Logic Controllers (PLCs)
- Point of Load (POL) Regulators
- Solid State Drives (SSDs)

## 3 Description

The TPS62097 device is a synchronous step-down converter optimized for high efficiency and noise critical applications. The devices focus on high efficiency conversion over a wide output current range. At medium to heavy loads, the converter operates in PWM mode and automatically enters Power Save Mode operation at light load. The switching frequency is selectable in the range of 1.5 MHz to 2.5 MHz by an external resistor. iDCS-Control is able to be operated in forced PWM mode for low noise operation with a fixed switching frequency.

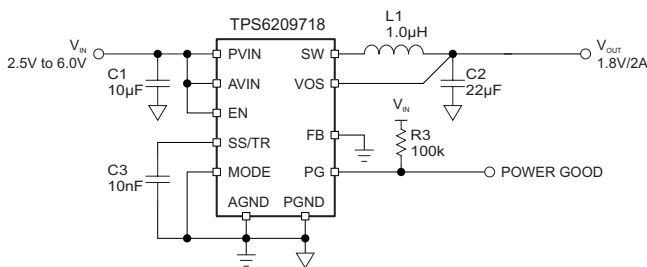
To address the requirements of system power rails, the internal compensation circuit allows a large selection of external output capacitor values in excess of 150  $\mu\text{F}$ . To control the inrush current during the startup, the device provides a programmable soft startup by an external capacitor connected to the SS/TR pin. The SS/TR pin is also used in voltage tracking configurations. The device integrates short circuit protection, power good and thermal shutdown features. The device is available in a 2-mm x 2-mm VQFN package.

### Device Information<sup>(1)</sup>

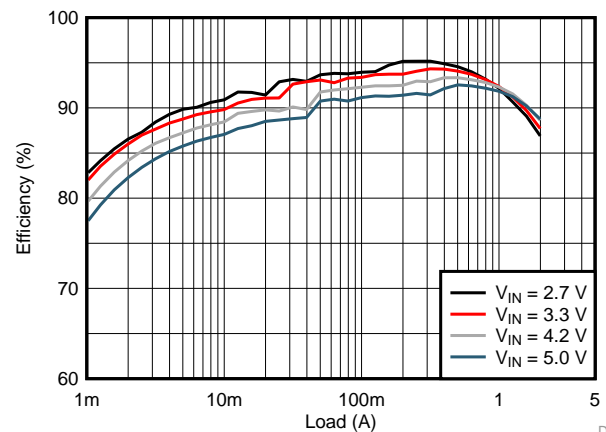
PART NUMBER	PACKAGE	BODY SIZE (NOM)
TPS62097	VQFN (11)	2.0 mm x 2.0 mm
TPS6209718		
TPS6209733		

(1) For all available packages, see the orderable addendum at the end of the data sheet.

### 1.8-V Output, PWM/PSM Mode Application



### 1.8-V Output, PWM/PSM Mode Efficiency



D003



## Table of Contents

<b>1 Features</b> ..... 1 <b>2 Applications</b> ..... 1 <b>3 Description</b> ..... 1 <b>4 Revision History</b> ..... 2 <b>5 Device Options</b> ..... 3 <b>6 Terminal Configuration and Functions</b> ..... 3 <b>7 Specifications</b> ..... 4 7.1 Absolute Maximum Ratings ..... 4 7.2 ESD Ratings..... 4 7.3 Recommend Operating Conditions..... 4 7.4 Thermal Information ..... 4 7.5 Electrical Characteristics..... 5 7.6 Typical Characteristics..... 6 <b>8 Detailed Description</b> ..... 7 8.1 Overview ..... 7 8.2 Functional Block Diagram ..... 7 8.3 Feature Description..... 8 8.4 Device Function Modes ..... 8	<b>9 Application Information</b> ..... 12 9.1 Application Information..... 12 9.2 1.2-V Output Application ..... 12 9.3 Coincidental Voltage Tracking ..... 18 9.4 Switching Frequency Selection ..... 19 <b>10 Power Supply Recommendations</b> ..... 20 <b>11 PCB Layout</b> ..... 21 11.1 Layout Guidelines ..... 21 11.2 Layout Example ..... 21 11.3 Thermal Information ..... 21 <b>12 Device and Documentation Support</b> ..... 22 12.1 Device Support ..... 22 12.2 Community Resources..... 22 12.3 Trademarks ..... 22 12.4 Electrostatic Discharge Caution..... 22 12.5 Glossary ..... 22 <b>13 Mechanical, Packaging, and Orderable Information</b> ..... 22
---	---

## 4 Revision History

NOTE: Page numbers for previous revisions may differ from page numbers in the current version.

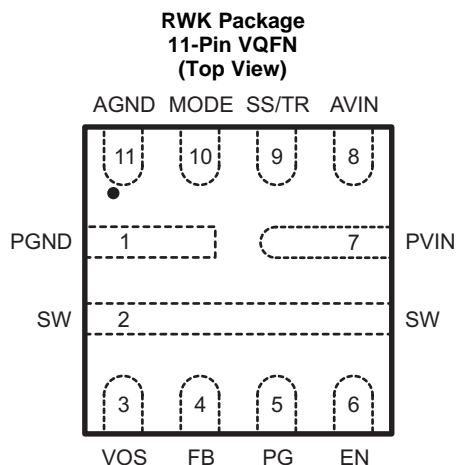
DATE	REVISION	NOTES
December 2015	*	Initial release.

## 5 Device Options

PART NUMBER <sup>(1)</sup>	OUTPUT VOLTAGE	PACKAGE MARKING
TPS62097	Adjustable	ZFZ5
TPS6209718	1.8V	ZGB5
TPS6209733	3.3V	ZGC5

(1) For detailed ordering information, please check the Mechanical, Packaging, and Orderable Information section at the end of this datasheet.

## 6 Terminal Configuration and Functions



**Pin Functions**

PIN		I/O	DESCRIPTION
NAME	NO.		
PGND	1		Power ground pin.
SW	2	PWR	Switch pin. It is connected to the internal MOSFET switches. Connect the external inductor between this terminal and the output capacitor.
VOS	3	I	Output voltage sense pin. This pin must be directly connected to the output capacitor.
FB	4	I	Feedback pin. For the fixed output voltage versions, this pin is recommended to be connected to AGND for improved thermal performance. The pin also can be left floating as an internal 400kΩ resistor is connected between this pin and AGND for fixed output voltage versions. For the adjustable output voltage version, a resistor divider sets the output voltage.
PG	5	O	Power good open drain output pin. The pull-up resistor should not be connected to any voltage higher than 6 V. If it's not used, leave the pin floating.
EN	6	I	Enable pin. To enable the device this pin needs to be pulled high. Pulling this pin low disables the device. This pin has an internal pull-down resistor of typically 375kΩ when the device is disabled.
PVIN	7	PWR	Power input supply pin.
AVIN	8	I	Analog input supply pin. Connect it to the PVIN pin together.
SS/TR	9	I	Soft startup and voltage tracking pin. A capacitor is connected to this pin to set the soft startup time. Leaving this pin floating sets the minimum startup time.
MODE	10	I	Mode selection pin. Connect this pin to AGND to enable Power Save Mode with automatic transition between PWM and Power Save Mode. Connect this pin to an external resistor or leave floating to enable forced PWM mode only. See <a href="#">Table 1</a> .
AGND	11		Analog ground pin.

## 7 Specifications

### 7.1 Absolute Maximum Ratings<sup>(1)</sup>

over operating free-air temperature range (unless otherwise noted)

		MIN	MAX	UNIT
Voltage at Pins <sup>(2)</sup>	AVIN, PVIN, EN, VOS, PG	-0.3	6.0	V
	MODE, SS/TR, SW	-0.3	V <sub>IN</sub> +0.3V	
	FB	-0.3	3.0	
Sink current	PG	0	1.0	mA
Temperature	Operating Junction, T <sub>J</sub>	-40	150	°C
	Storage, T <sub>stg</sub>	-65	150	

- (1) Stresses beyond those listed under absolute maximum ratings may cause permanent damage to the device. These are stress ratings only, and functional operation of the device at these or any other conditions beyond those indicated under recommended operating conditions is not implied. Exposure to absolute-maximum-rated conditions for extended periods may affect device reliability.
- (2) All voltage values are with respect to network ground terminal.

### 7.2 ESD Ratings

		VALUE	UNIT
V <sub>ESD</sub>	Electrostatic discharge	Human Body Model (HBM) ESD stress voltage <sup>(1)</sup>	±2000
		Charged Device Model (CDM) ESD stress voltage <sup>(2)</sup>	±500

- (1) JEDEC document JEP155 states that 500V HBM allows safe manufacturing with a standard ESD control process.
- (2) JEDEC document JEP157 states that 250V CDM allows safe manufacturing with a standard ESD control process.

### 7.3 Recommend Operating Conditions

Over operating free-air temperature range, unless otherwise noted.

		MIN	MAX	UNIT
V <sub>IN</sub>	Input voltage range	2.5	6.0	V
V <sub>PG</sub>	Pull-up resistor voltage	0	6.0	V
V <sub>OUT</sub>	Output voltage range	0.8	V <sub>IN</sub>	V
I <sub>OUT</sub>	Output current range	0	2.0	A
T <sub>J</sub>	Operating junction temperature	-40	125	°C

### 7.4 Thermal Information

THERMAL METRIC <sup>(1)</sup>		TPS62097xx RWK (11 TERMINALS)	UNITS
R <sub>θJA</sub>	Junction-to-ambient thermal resistance	83.4	°C/W
R <sub>θJC(top)</sub>	Junction-to-case (top) thermal resistance	61.0	°C/W
R <sub>θJB</sub>	Junction-to-board thermal resistance	19.9	°C/W
Ψ <sub>JT</sub>	Junction-to-top characterization parameter	4.4	°C/W
Ψ <sub>JB</sub>	Junction-to-board characterization parameter	19.9	°C/W
R <sub>θJC(bot)</sub>	Junction-to-case (bottom) thermal resistance	2.0	°C/W

- (1) For more information about traditional and new thermal metrics, see the IC Package Thermal Metrics application report, [SPRA953](#)

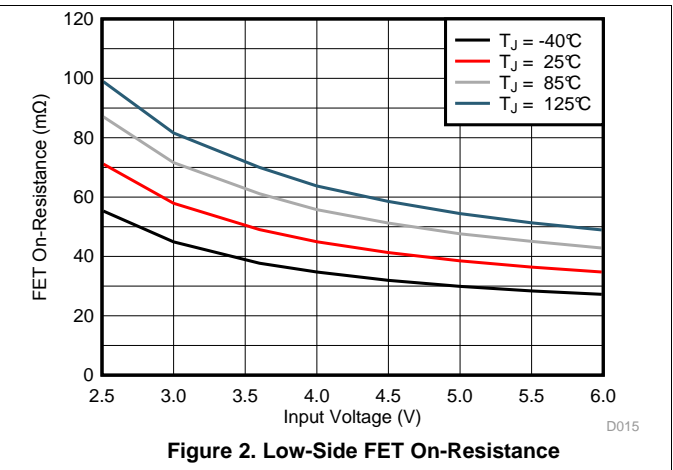
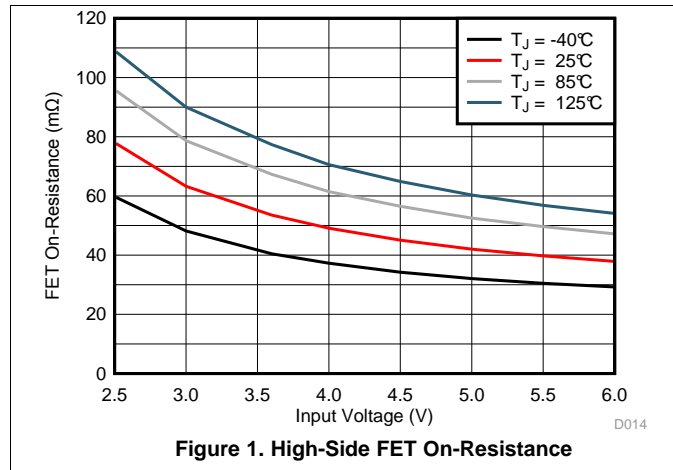
## 7.5 Electrical Characteristics

$T_J = -40^{\circ}\text{C}$  to  $125^{\circ}\text{C}$ , and  $V_{IN} = 2.5\text{V}$  to  $6.0\text{V}$ . Typical values are at  $T_J = 25^{\circ}\text{C}$  and  $V_{IN} = 3.6\text{V}$ , unless otherwise noted.

PARAMETER		TEST CONDITIONS	MIN	TYP	MAX	UNIT
<b>SUPPLY</b>						
$I_Q$	Quiescent current into AVIN, PVIN	EN = High, Device not switching, $T_J = -40^{\circ}\text{C}$ to $85^{\circ}\text{C}$	40	57		$\mu\text{A}$
		EN = High, Device not switching	40	65		
$I_{SD}$	Shutdown current into AVIN, PVIN	EN = Low, $T_J = -40^{\circ}\text{C}$ to $85^{\circ}\text{C}$	0.7	3		$\mu\text{A}$
		EN = Low	0.7	10		
$V_{UVLO}$	Under voltage lock out threshold	$V_{IN}$ falling	2.2	2.3	2.4	V
		$V_{IN}$ rising	2.3	2.4	2.5	
$T_{JSD}$	Thermal shutdown threshold	$T_J$ rising	160			$^{\circ}\text{C}$
	Thermal shutdown hysteresis	$T_J$ falling	20			$^{\circ}\text{C}$
<b>LOGIC INTERFACE (EN, MODE)</b>						
$V_{H\_EN}$	High-level input voltage, EN pin		2.0	1.6		V
$V_{L\_EN}$	Low-level input voltage, EN pin			1.3	1.0	V
$I_{EN,LKG}$	Input leakage current into EN pin	EN = High		0.01	0.9	$\mu\text{A}$
$R_{PD}$	Pull-down resistance at EN pin	EN = Low		375		k $\Omega$
$V_{H\_MO}$	High-level input voltage, MODE pin		1.2			V
$V_{L\_MO}$	Low-level input voltage, MODE pin				0.4	V
$I_{MO,LKG}$	Input leakage current into MODE pin	MODE = High		0.01	0.16	$\mu\text{A}$
<b>SOFT STARTUP, POWER GOOD (SS/TR, PG)</b>						
$I_{SS}$	Soft startup current		5.5	7.5	9.5	$\mu\text{A}$
	Voltage tracking gain factor	$V_{FB} / V_{SS/TR}$		1		
$V_{PG}$	Power good threshold	$V_{OUT}$ rising, referenced to $V_{OUT}$ nominal	92	95	98	%
		$V_{OUT}$ falling, referenced to $V_{OUT}$ nominal	87	90	92	
$V_{PG,OL}$	Low-level output voltage, PG pin	$I_{sink} = 1\text{mA}$			0.4	V
$I_{PG,LKG}$	Input leakage current into PG pin	$V_{PG} = 5.0\text{V}$		0.01	1.6	$\mu\text{A}$
<b>OUTPUT</b>						
$V_{OUT}$	Output voltage accuracy TPS6209718, TPS6209733	PWM mode, No load	-1.0		1.0	%
		PSM mode <sup>(1)</sup>	-1.0		2.1	
$V_{FB}$	Feedback reference voltage	PWM mode	792	800	808	mV
		PSM mode <sup>(1)</sup>	792	800	817	
$I_{FB,LKG}$	Input leakage current into FB pin	$V_{FB} = 0.8\text{V}$		0.01	0.1	$\mu\text{A}$
$R_{DIS}$	Output discharge resistor	EN = Low, $V_{OUT} = 1.8\text{V}$		165		$\Omega$
	Line regulation	$I_{OUT} = 0.5\text{A}$ , $V_{OUT} = 1.8\text{V}$ <sup>(1)</sup>		0.02		%/V
	Load regulation	PWM mode, $V_{OUT} = 1.8\text{V}$ <sup>(1)</sup>		0.2		%/A
<b>POWER SWITCH</b>						
$R_{DS(on)}$	High-side FET on-resistance	$I_{SW} = 500\text{mA}$ , $V_{IN} = 5.0\text{V}$		40	73	m $\Omega$
		$I_{SW} = 500\text{mA}$ , $V_{IN} = 3.6\text{V}$		50	96	
	Low-side FET on-resistance	$I_{SW} = 500\text{mA}$ , $V_{IN} = 5.0\text{V}$		40	68	m $\Omega$
		$I_{SW} = 500\text{mA}$ , $V_{IN} = 3.6\text{V}$		50	85	
$I_{LIMF}$	High-side FET forward current limit		3.1	3.6	4.2	A
		$V_{IN} = 5.0\text{V}$	3.3	3.6	3.9	
$I_{LIMN}$	Low-side FET negative current limit	Forced PWM mode	-1.25	-1.1	-0.7	A

(1) Conditions: L = 1 $\mu\text{H}$ ,  $C_{OUT} = 22\mu\text{F}$ , Switching Frequency = 2.0MHz

## 7.6 Typical Characteristics





## 8.3 Feature Description

### 8.3.1 100% Duty Cycle Mode

The device offers a low input to output voltage dropout by entering 100% duty cycle mode, when the input voltage reaches the level of the output voltage. In this mode the high-side MOSFET switch is constantly turned on and the low-side MOSFET is switched off. The minimum input voltage to maintain output regulation, depending on the load current and output voltage, is calculated as:

$$V_{IN(min)} = V_{OUT(min)} + I_{OUT} \times (R_{DS(on)} + R_L)$$

where

- $V_{IN(min)}$  = Minimum input voltage to maintain a minimum output voltage
- $I_{OUT}$  = Output current
- $R_{DS(on)}$  = High side FET on-resistance
- $R_L$  = Inductor ohmic resistance (DCR) (1)

When the device operates close to 100% duty cycle mode, the TPS62097 can't enter Power Save Mode regardless of the load current if the input voltage decreases to typically 15% above the output voltage. The device maintains output regulation in PWM mode.

### 8.3.2 Switch Current Limit and Hiccup Short Circuit Protection

The switch current limit prevents the devices from high inductor current and from drawing excessive current from the battery or input voltage rail. Excessive current might occur with a shorted/saturated inductor or a heavy load/shorted output circuit condition. If the inductor current reaches the threshold  $I_{LIMF}$ , the high-side MOSFET is turned off and the low-side MOSFET is turned on to ramp down the inductor current. Once this switch current limit is triggered 32 times, the devices stop switching and enable the output discharge. The devices then automatically start a new startup after a typical delay time of 100 $\mu$ s has passed. This is HICCUP short circuit protection and is implemented to reduce the current drawn during a short circuit condition. The devices repeat this mode until the high load condition disappears.

When the device is in forced PWM mode, the negative current limit of the low-side MOSFET is active. The negative current limit prevents excessive current from flowing back through the inductor to the input.

### 8.3.3 Under Voltage Lockout (UVLO)

To avoid mis-operation of the device at low input voltages, an under voltage lockout is implemented, which shuts down the devices at voltages lower than  $V_{UVLO}$  with a hysteresis of 100mV.

### 8.3.4 Thermal Shutdown

The device goes into thermal shutdown and stops switching once the junction temperature exceeds  $T_{JSD}$ . Once the device temperature falls below the threshold by 20°C, the device returns to normal operation automatically.

## 8.4 Device Function Modes

### 8.4.1 Enable and Disable (EN)

The device is enabled by setting the EN pin to a logic High. Accordingly, shutdown mode is forced if the EN pin is pulled Low with a shutdown current of typically 0.7  $\mu$ A.

In shutdown mode, the internal power switches as well as the entire control circuitry are turned off. An internal resistor of 165  $\Omega$  discharges the output via the VOS pin smoothly. The output discharge function also works when thermal shutdown, undervoltage lockout or HICCUP short circuit protection are triggered.

An internal pull-down resistor of 375 k $\Omega$  is connected to the EN pin when the EN pin is Low. The pull-down resistor is disconnected when the EN pin is High.

### 8.4.2 Power Save Mode and Forced PWM Mode (MODE)

The MODE pin is a multi-functional pin that allows the device operation in forced PWM mode or PWM/PSM mode, and to select the PWM switching frequency.

### Device Function Modes (continued)

Once the EN pin is pulled high, the IC enables internal circuit blocks and prepares to ramp the output up. The period between the rising edge of the EN pin and the beginning of the power stage switching is called the MODE detection time, typically 50µs. During the MODE detection time period, shown in Figure 3, the PWM switching frequency and operating mode are set by the MODE pin status, as shown in Table 1.

The PWM switching frequency can't be changed after the detection time period. Only when the device is set in PWM/PSM mode during the MODE detection time period (MODE = AGND), it is possible to switch between PWM/PSM and forced PWM operation modes by toggling the MODE pin with a GPIO pin of a micro-controller, for example. The other four MODE pin selections force the device in PWM mode only.

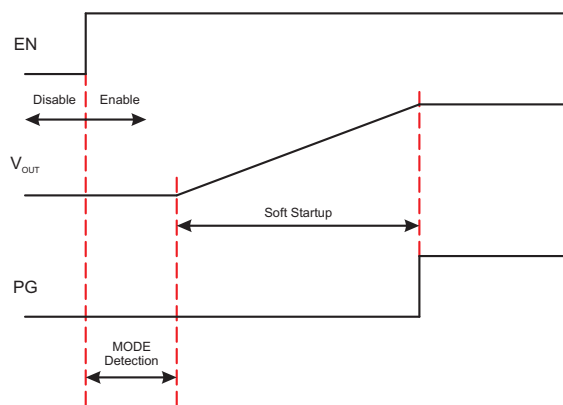


Figure 3. Power Up Sequence

Table 1. Switching Frequency and Mode Selection

Typical PWM Switching Frequency (MHz)	Resistance at MODE pin (E24 EIA Value)	Toggle MODE pin after MODE detection	ON-Time Equation	Operating Mode
1.50	8.2kΩ ±5%	No	$t_{ON} = 667ns \times V_{OUT} / V_{IN}$	Forced PWM
1.75	18kΩ ±5%	No	$t_{ON} = 571ns \times V_{OUT} / V_{IN}$	Forced PWM
2.00	AGND	Yes	$t_{ON} = 500ns \times V_{OUT} / V_{IN}$	PWM/PSM and Forced PWM
2.25	39kΩ ±5%	No	$t_{ON} = 444ns \times V_{OUT} / V_{IN}$	Forced PWM
2.50	75kΩ ±5% or Open	No	$t_{ON} = 400ns \times V_{OUT} / V_{IN}$	Forced PWM

Connecting the MODE pin to AGND with a resistor or leaving the MODE pin open forces the device into PWM mode for the whole load range. The device operates with a fixed switching frequency that allows simple filtering of the switching frequency for noise sensitive applications. In forced PWM mode, the efficiency is lower than that of PSM at light load.

Connecting the MODE pin to the AGND pin enables Power Save Mode with an automatic transition between PWM and Power Save Mode. As the load current decreases and the inductor current becomes discontinuous, the device enters Power Save Mode operation automatically. In Power Save Mode, the switching frequency is reduced and estimated by Equation 2. In Power Save Mode, the output voltage rises slightly above the nominal output voltage, as shown in Figure 13. This effect is minimized by increasing the output capacitor.

$$f_{PSM} = \frac{2 \times I_{OUT}}{t_{ON}^2 \times \frac{V_{IN}}{V_{OUT}} \times \frac{V_{IN} - V_{OUT}}{L}} \quad (2)$$

When the device operates close to 100% duty cycle mode, the TPS62097 can't enter Power Save Mode regardless of the load current if the input voltage decreases to typically 15% above the output voltage. The device maintains output regulation in PWM mode.

### 8.4.3 Soft Startup (SS/TR)

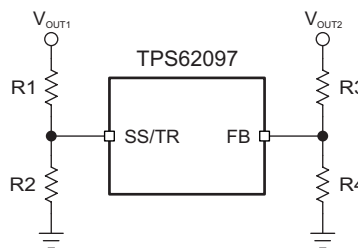
The TPS62097 programs its output voltage ramp rate with the SS/TR pin. Connecting an external capacitor to SS/TR enables output soft startup to reduce inrush current from the input supply. The device charges the capacitor voltage to the input supply voltage with a constant current of typically 7.5µA. The FB pin voltage follows the SS/TR pin voltage until the internal reference voltage of 0.8V is reached. The soft startup time is calculated using Equation 3. Keep the SS/TR pin floating to set the minimum startup time.

$$t_{SS} = C_{SS/TR} \times \frac{0.8V}{7.5\mu A} \quad (3)$$

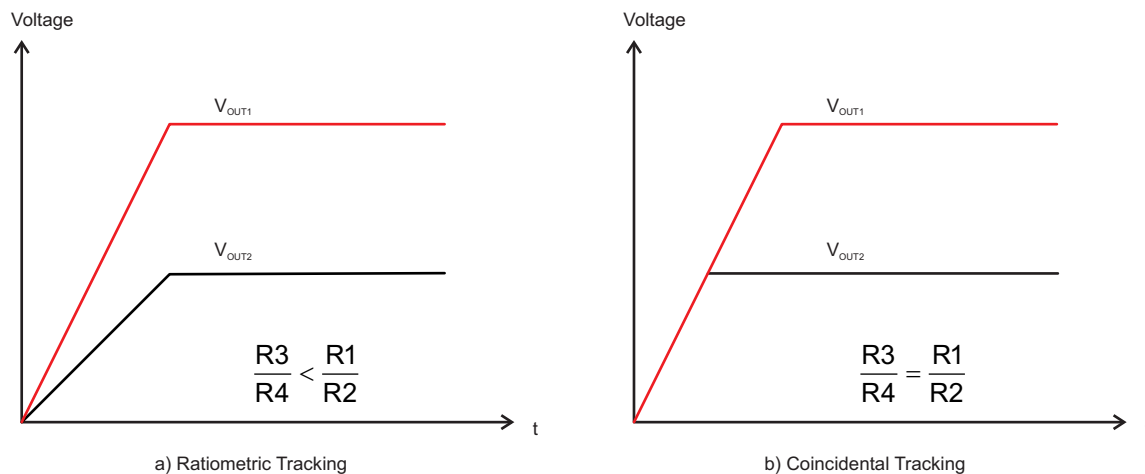
An active pull-down circuit is connected to the SS/TR pin. It discharges the external soft startup capacitor in case of disable, UVLO, thermal shutdown and HICCUP short circuit protection.

### 8.4.4 Voltage Tracking (SS/TR)

The SS/TR pin is externally driven by another voltage source to achieve output voltage tracking. The application circuit is shown in Figure 4. From 0 V to 0.8 V, the internal reference voltage to the internal error amplifier follows the SS/TR pin voltage. When the SS/TR pin voltage is above 0.8 V, the voltage tracking is disabled and the FB pin voltage is regulated at 0.8 V. The device achieves ratiometric or coincidental (simultaneous) output tracking, as shown in Figure 5.



**Figure 4. Output Voltage Tracking**



**Figure 5. Voltage Tracking Options**

The R2 value should be set properly to achieve accurate voltage tracking by taking 7.5 µA soft startup current into account. 1 kΩ or smaller is a sufficient value for R2.

For decreasing SS/TR pin voltage, the device doesn't sink current from the output when the device is in PSM. So the resulting decreases of the output voltage may be slower than the SS/TR pin voltage if the load is light. When driving the SS/TR pin with an external voltage, do not exceed the voltage rating of the SS/TR pin which is  $V_{IN}+0.3V$ .

#### **8.4.5 Power Good (PG)**

The TPS62097 has a power good output. The PG pin goes high impedance once the output voltage is above 95% of the nominal voltage, and is driven low once the output voltage falls below typically 90% of the nominal voltage. The PG pin is an open drain output and is specified to sink up to 1mA. The power good output requires a pull-up resistor connected to any voltage rail less than 6V. The PG pin goes low when the device is disabled or in thermal shutdown. When the devices are in UVLO, the PG pin is high impedance.

The PG signal can be used for sequencing of multiple rails by connecting it to the EN pin of other converters. Leave the PG pin floating when not used.

## 9 Application Information

### NOTE

Information in the following applications sections is not part of the TI component specification, and TI does not warrant its accuracy or completeness. TI's customers are responsible for determining suitability of components for their purposes. Customers should validate and test their design implementation to confirm system functionality.

### 9.1 Application Information

The following section discusses the design of the external components to complete the power supply design of the TPS62097.

### 9.2 1.2-V Output Application

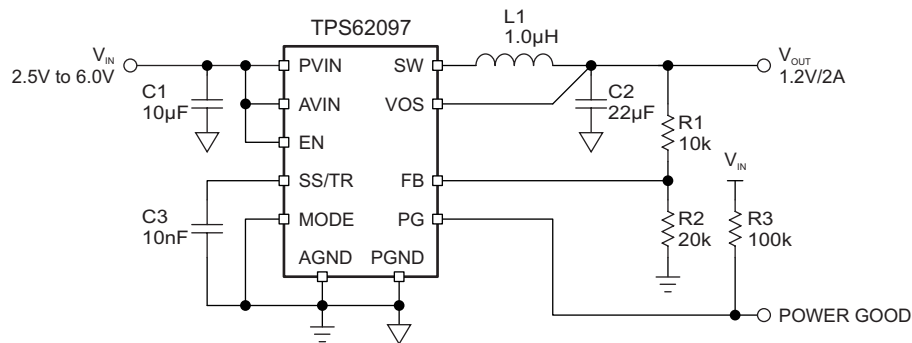


Figure 6. 1.2-V Output Application Schematic

#### 9.2.1 Design Requirements

For this design example, use the following as the input parameters.

Table 2. Design Parameters

DESIGN PARAMETER	EXAMPLE VALUE
Input voltage range	2.5 V to 6 V
Output voltage	1.2 V
Output current	2.0 A
Output voltage ripple	< 30 mV

Table 3 lists the components used for the example.

Table 3. List of Components

REFERENCE	DESCRIPTION	MANUFACTURER
C1	10 µF, Ceramic Capacitor, 6.3V, X7R, size 0805, C2012X7R0J106M125AB	TDK
C2	22 µF, Ceramic Capacitor, 6.3V, X7S, size 0805, C2012X7S1A226M125AC	TDK
C3	10 nF, Ceramic Capacitor, 6.3V, X7R, size 0603, GRM188R70J103KA01	Murata
L1	1 µH, Shielded, 5.4A, XFL4020-102MEB	Coilcraft
R1	Depending on the output voltage, 1% accuracy	Std
R2	20 kΩ, 1% accuracy	Std
R3	100 Ωk, 1% accuracy	Std

## 9.2.2 Detailed Design Procedure

### 9.2.2.1 Setting the Output Voltage

The output voltage is set by an external resistor divider according to the following equation:

$$V_{OUT} = V_{FB} \times \left(1 + \frac{R1}{R2}\right) = 0.8 \text{ V} \times \left(1 + \frac{R1}{R2}\right) \quad (4)$$

R2 should not be higher than 20 kΩ to reduce noise coupling into the FB pin and improve the output voltage regulation. [Figure 6](#) shows the external resistor divider value for 1.2-V output. Choose additional resistor values for other outputs. A feed forward capacitor is not required.

The fixed output voltage versions, TPS6209718 and TPS6209733, do not need the external resistor divider. TI recommends to connect the FB pin to AGND for improved thermal performance.

### 9.2.2.2 Output Filter Design

The inductor and the output capacitor together provide a low-pass filter. To simplify the selection process, [Table 4](#) outlines possible inductor and capacitor value combinations for most applications.

**Table 4. Output Capacitor / Inductor Combinations**

NOMINAL L [μH] <sup>(1)</sup>	NOMINAL C <sub>OUT</sub> [μF] <sup>(2)</sup>				
	10	22	47	100	150
0.47					
1		+(3)	+	+	+
2.2					

- (1) Inductor tolerance and current de-rating is anticipated. The effective inductance can vary by +20% and -30%. The required effective inductance is 500nH minimum.
- (2) Capacitance tolerance and bias voltage de-rating is anticipated. The effective capacitance can vary by 20% and -50%.
- (3) Typical application configuration. Other '+' mark indicates recommended filter combinations. Other values may be acceptable in applications but should be fully tested by the user. Refer to the application note [SLVA710](#).

### 9.2.2.3 Inductor Selection

The main parameters for the inductor selection are the inductor value and the saturation current. To calculate the maximum inductor current under static load conditions, [Equation 5](#) is given.

$$I_{L,MAX} = I_{OUT,MAX} + \frac{\Delta I_L}{2}$$

$$\Delta I_L = V_{OUT} \times \frac{1 - \frac{V_{OUT}}{V_{IN}}}{L \times f_{SW}} \quad (5)$$

Where:

- I<sub>OUT,MAX</sub> = Maximum output current
- ΔI<sub>L</sub> = Inductor current ripple
- f<sub>SW</sub> = Switching frequency
- L = Inductor value

TI recommends to choose the saturation current for the inductor 20% to 30% higher than the I<sub>L,MAX</sub>, out of [Equation 5](#). A higher inductor value is also useful to lower ripple current but increases the transient response time as well. The following inductors are recommended to be used in designs.

**Table 5. List of Recommended Inductors<sup>(1)</sup>**

INDUCTANCE [μH]	CURRENT RATING [A]	DIMENSIONS L x W x H [mm <sup>3</sup> ]	DC RESISTANCE [mΩ typ]	PART NUMBER
1	5.4	4.0x4.0x2.0	11	COILCRAFT XFL4020-102ME
1	5.3	2.5x2.0x1.2	33	TOKO DFE252012F-1R0M
1	3.4	2.0x1.2x1.0	62	TOKO DFE201210S-1R0M
1	5.1	3.0x3.0x1.2	43	TAIYO YUDEN MDMK3030T1R0MM
1	4.2	2.5x2.0x1.2	43	CYNTEC SDEM25201B-1R0MS-79
1	2.6	2.5x2.0x1.2	48	Murata LQH2HPN1R0NJR
1	6.6	3.0x3.0x1.2	42	Würth Electronics 74438334010

(1) See [Third-Party Products Disclaimer](#)

### 9.2.2.4 Capacitor Selection

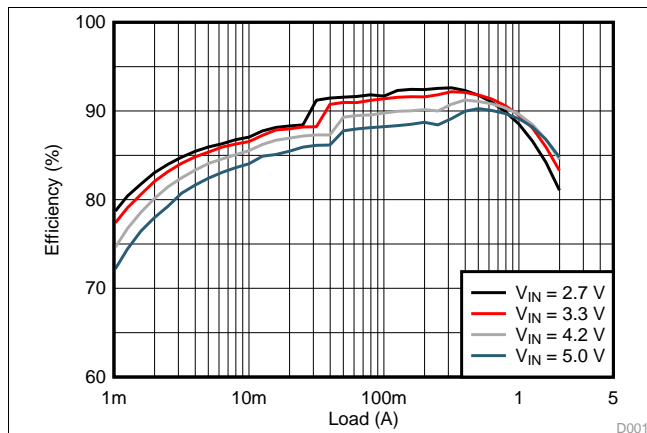
The input capacitor is the low impedance energy source for the converters which helps to provide stable operation. A low ESR multilayer ceramic capacitor is required for best filtering and should be placed between PVIN and PGND as close as possible to those pins. For most applications a 10-μF capacitor is sufficient, though a larger value reduces input current ripple.

The architecture of the TPS62097 allows the use of tiny ceramic output capacitors with low equivalent series resistance (ESR). These capacitors provide low output voltage ripple and are recommended. To keep its low resistance up to high frequencies and to get narrow capacitance variation with temperature, TI recommends to use X7R or X5R dielectrics. The recommended typical output capacitor value is 22 μF and can vary over a wide range as outlined in [Table 5](#).

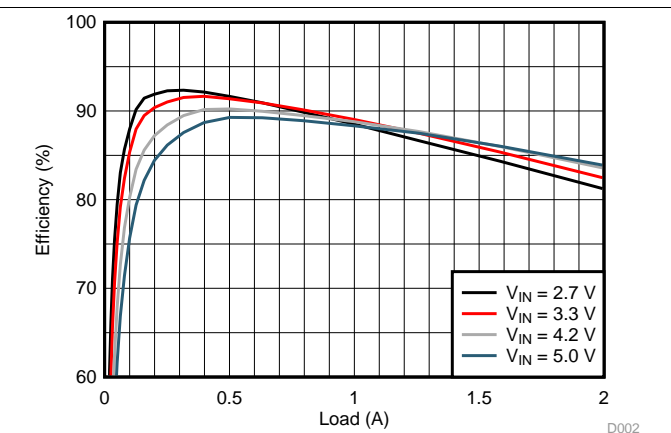
Ceramic capacitors have a DC-Bias effect, which has a strong influence on the final effective capacitance. Choose the right capacitor carefully in combination with considering its package size and voltage rating. Ensure that the input effective capacitance is at least 5 μF and the output effective capacitance is at least 10 μF.

### 9.2.3 Application Performance Curves

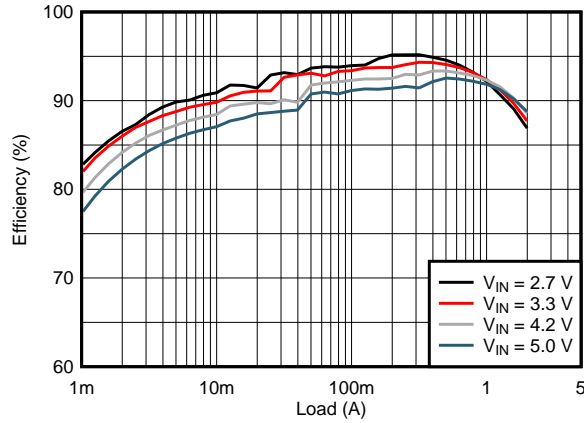
T<sub>A</sub> = 25°C, V<sub>IN</sub> = 3.6V, unless otherwise noted.



**Figure 7. Efficiency, PWM/PSM Mode (2.0 MHz)**

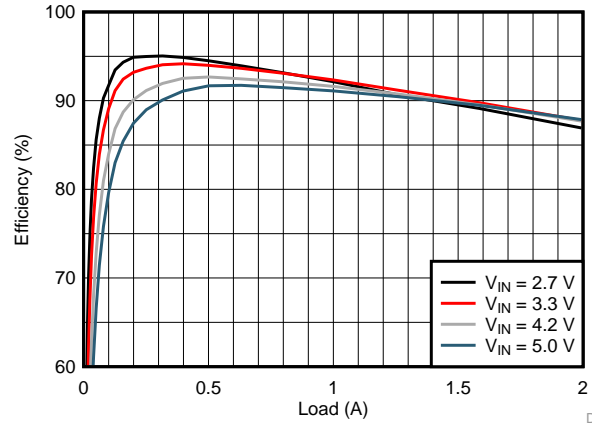


**Figure 8. Efficiency, Forced PWM Mode (2.0MHz)**



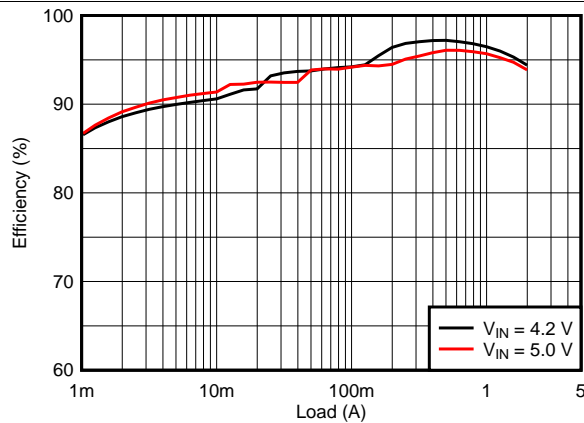
V<sub>OUT</sub> = 1.8 V

Figure 9. Efficiency, PWM/PSM Mode (2.0MHz)



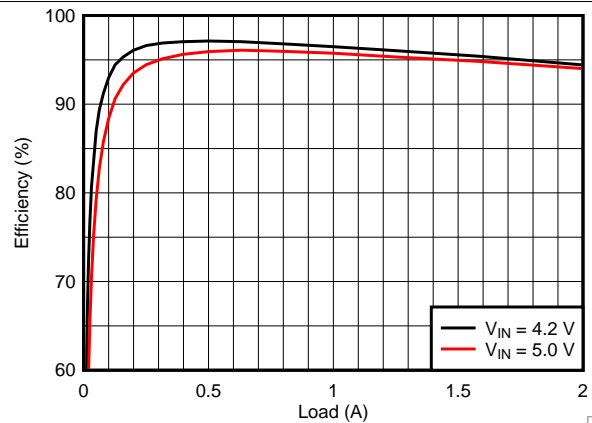
V<sub>OUT</sub> = 1.8 V

Figure 10. Efficiency, Forced PWM Mode (2.0MHz)



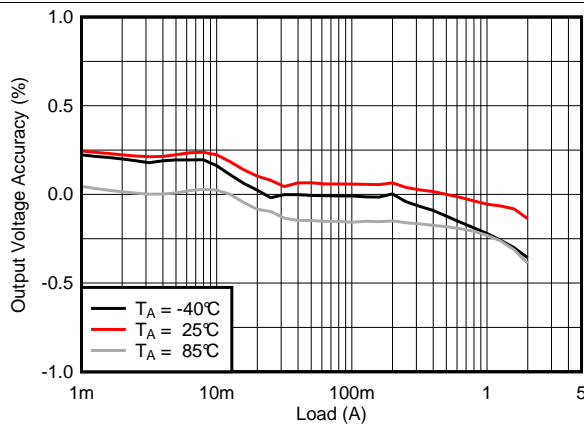
V<sub>OUT</sub> = 3.3 V

Figure 11. Efficiency, PWM/PSM Mode (2.0MHz)



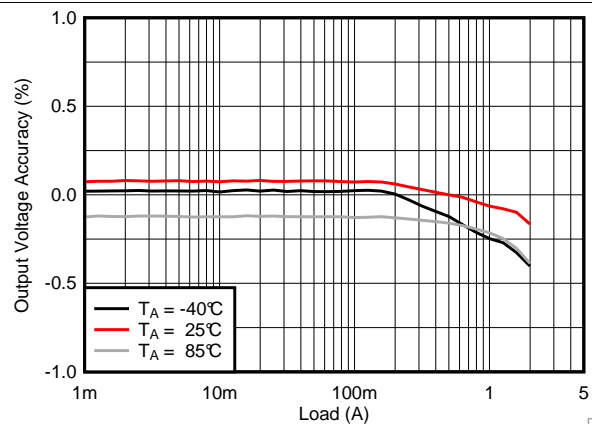
V<sub>OUT</sub> = 3.3 V

Figure 12. Efficiency, Forced PWM Mode (2.0MHz)



V<sub>OUT</sub> = 1.2 V

Figure 13. Load Regulation, PWM/PSM Mode (2.0MHz)



V<sub>OUT</sub> = 1.2 V

Figure 14. Load Regulation, Forced PWM Mode (2.0MHz)

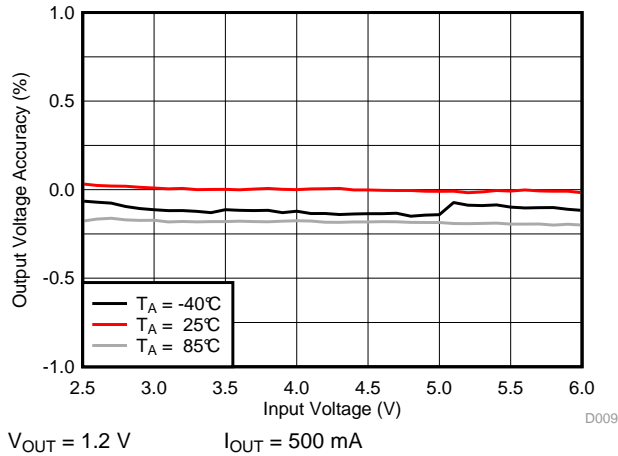


Figure 15. Line Regulation, Forced PWM Mode (2.0MHz)

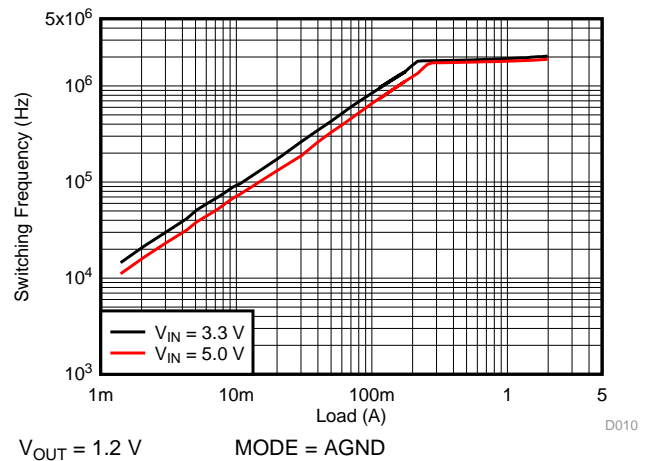


Figure 16. Switching Frequency, PWM/PSM Mode (2.0MHz)

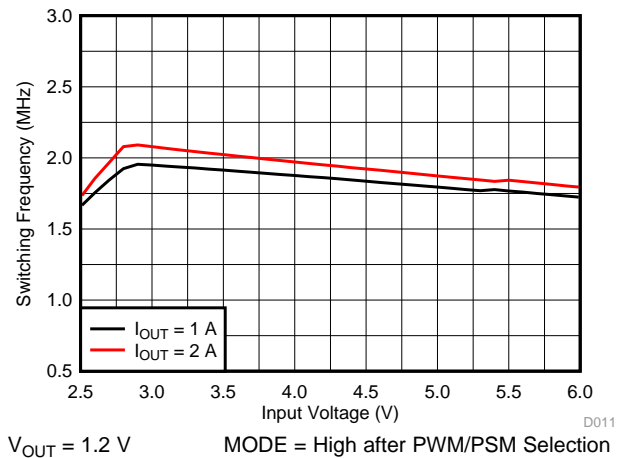


Figure 17. Switching Frequency, Forced PWM Mode (2.0MHz)

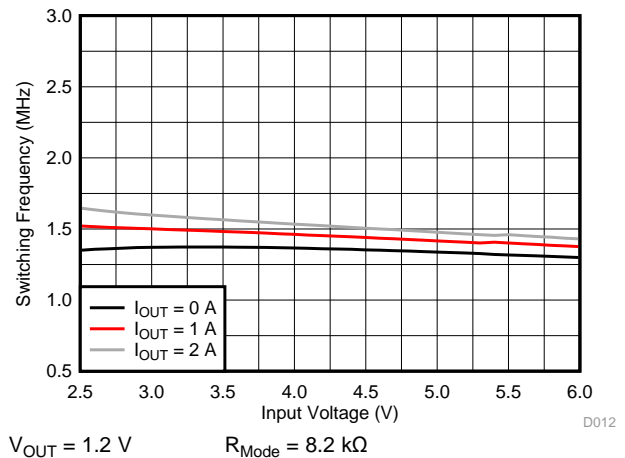


Figure 18. Switching Frequency, Forced PWM Mode (1.5MHz)

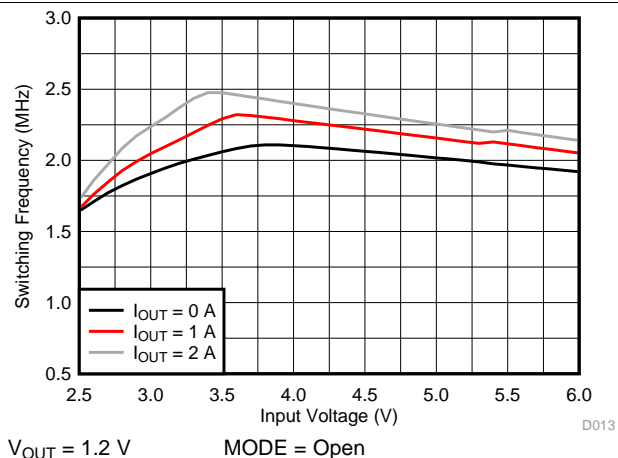


Figure 19. Switching Frequency, Forced PWM Mode (2.5MHz)

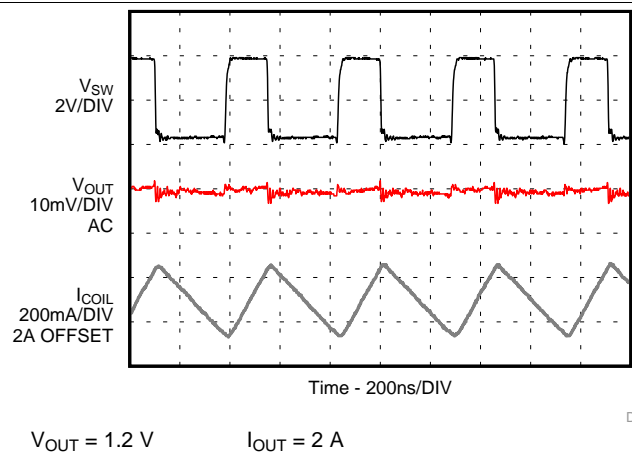
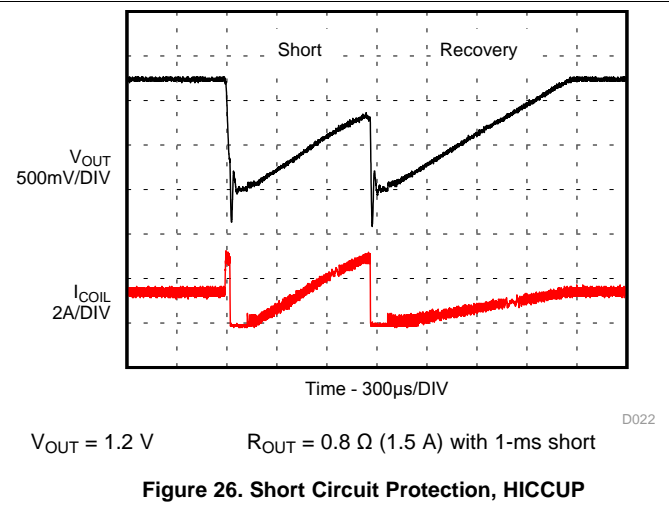
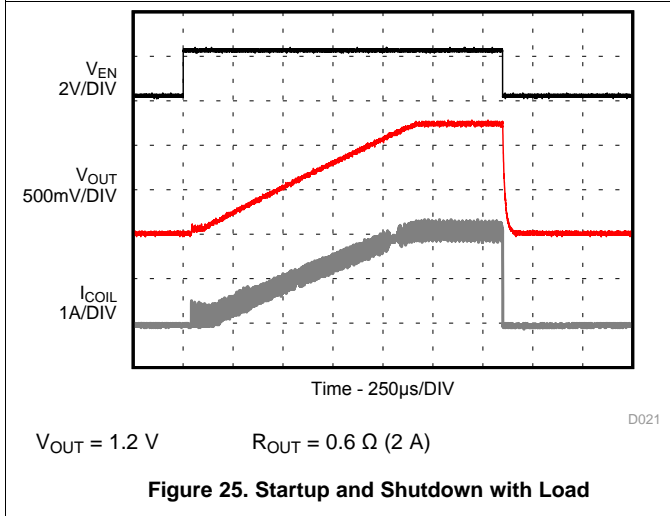
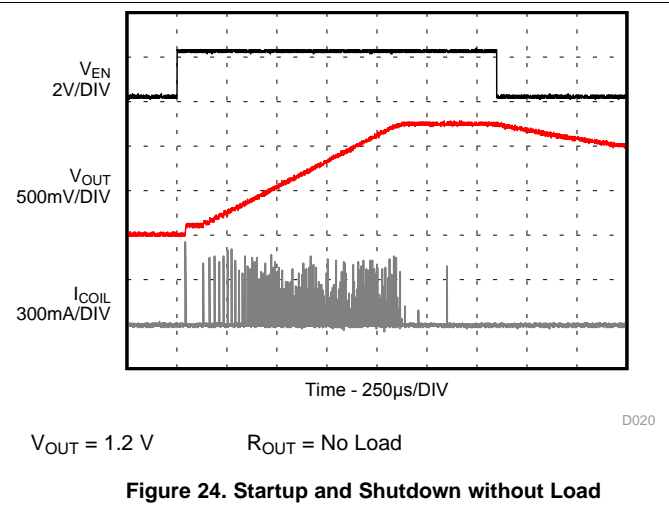
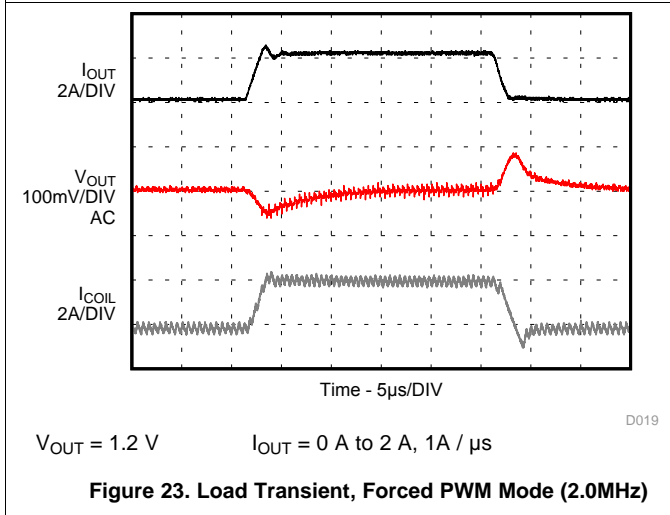
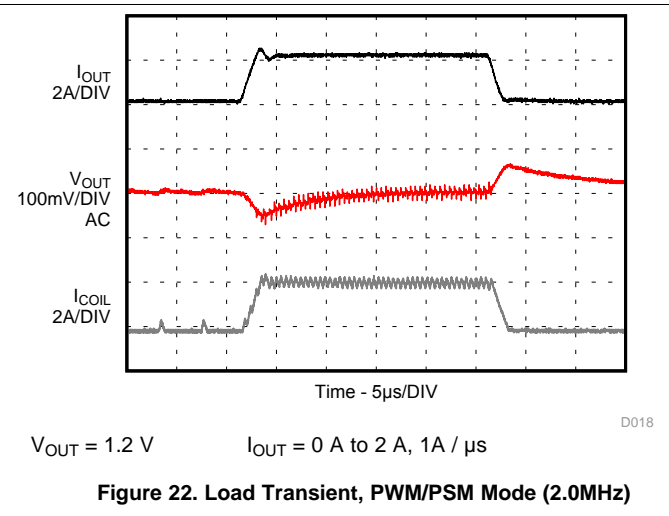
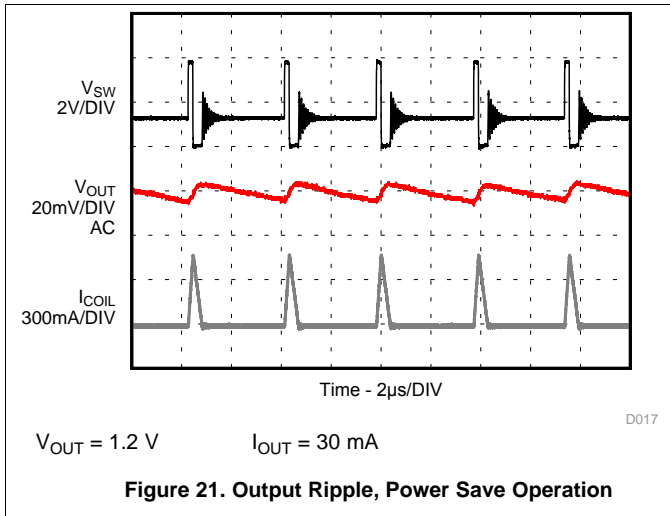
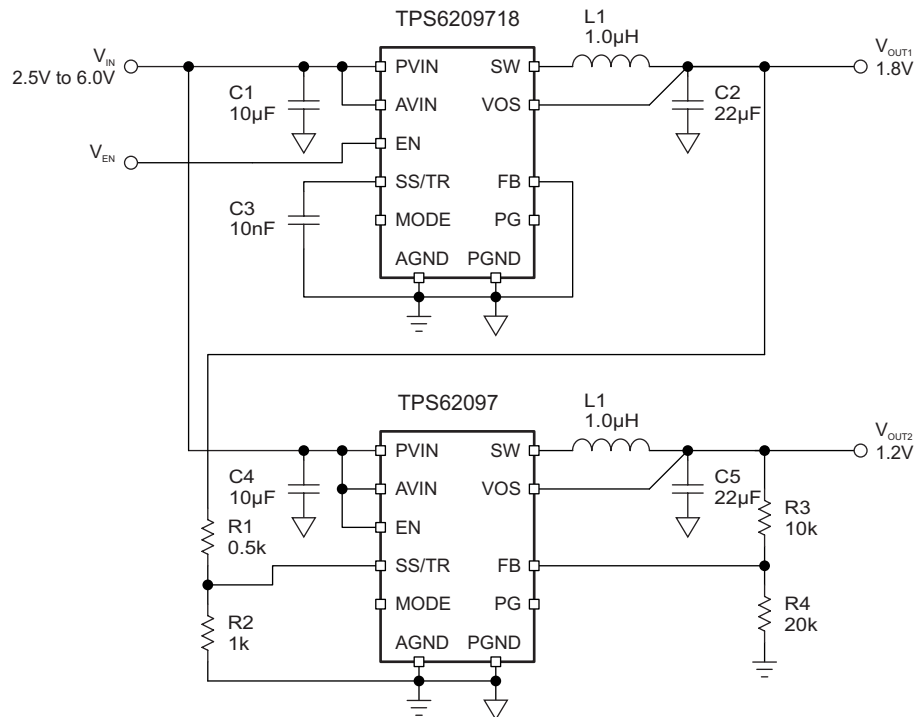


Figure 20. Output Ripple, PWM Operation (2.0MHz)



### 9.3 Coincidental Voltage Tracking



**Figure 27. 1.8-V and 1.2-V Coincidental Voltage Tracking Schematic**

#### 9.3.1 Design Requirements

For this design example, use the following as the input parameters.

**Table 6. Design Parameters**

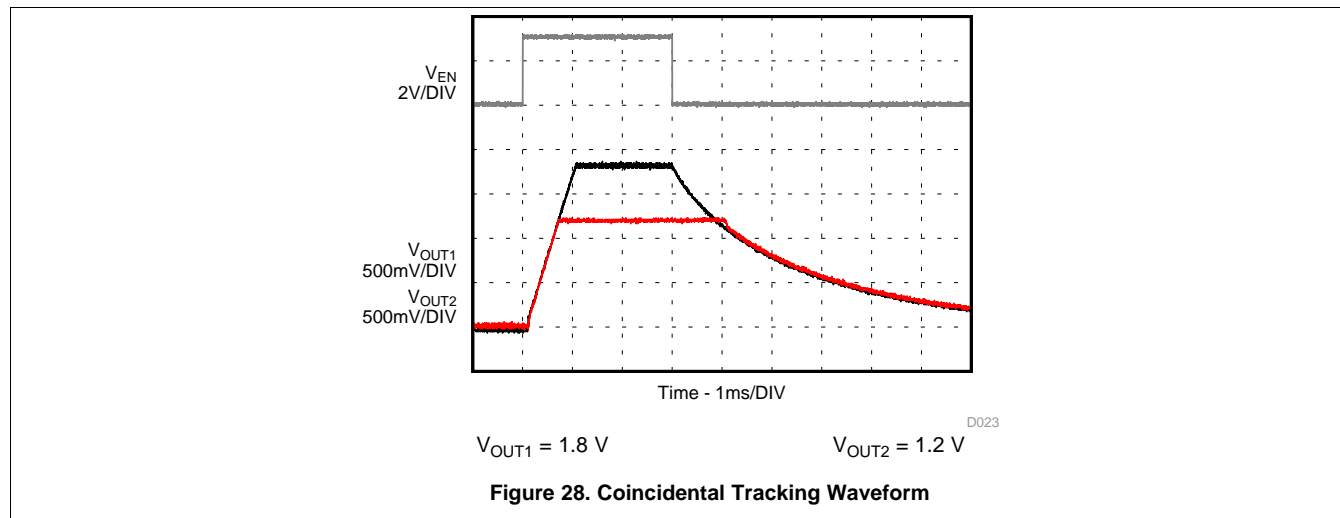
DESIGN PARAMETER	EXAMPLE VALUE
Input voltage range	2.5 V to 6 V
Output voltage 1	1.8 V
Output voltage 2	1.2 V
Output voltage 2 follows output voltage 1 coincidentally.	

#### 9.3.2 Detailed Design Procedure

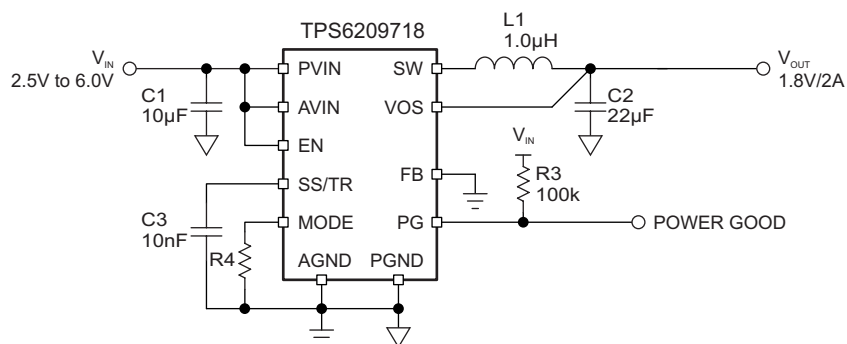
Set 1kΩ for R2 and 0.5kΩ for R1. Connect the two converters as shown in [Figure 27](#). Set up two converters in forced PWM mode.

### 9.3.3 Application Performance Curves

$T_A = 25^\circ\text{C}$ ,  $V_{IN} = 5.0\text{V}$ , unless otherwise noted.



### 9.4 Switching Frequency Selection



**Figure 29. Switching Frequency Selection by An External Resistor**

#### 9.4.1 Design Requirements

For this design example, use the following as the input parameters.

**Table 7. Design Parameters**

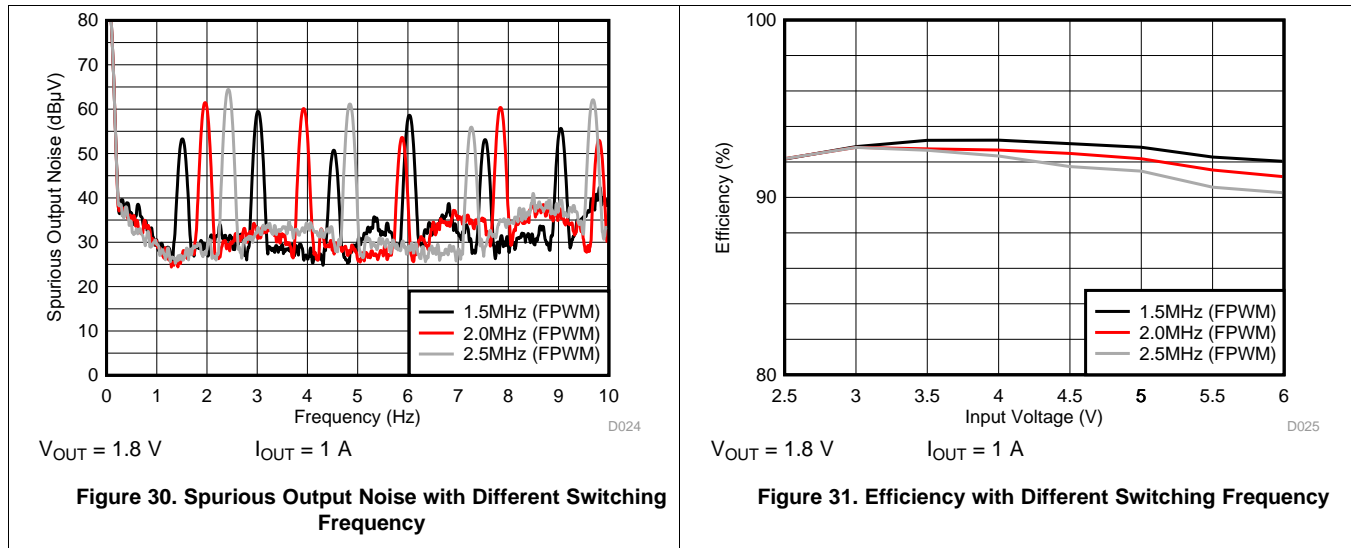
DESIGN PARAMETER	EXAMPLE VALUE
Input voltage range	2.5 V to 6 V
Output voltage 1	1.8 V
Switching Frequency Selection	1.5 MHz, 2.0 MHz or 2.5 MHz

#### 9.4.2 Detailed Design Procedure

Set 8.2 k $\Omega$  and 75 k $\Omega$  for 1.5 MHz, 2.0 MHz and 2.5 MHz switching frequency. R4 uses the standard E24 series resistor values.

### 9.4.3 Application Performance Curves

T<sub>A</sub> = 25°C, V<sub>IN</sub> = 5.0 , unless otherwise noted.



## 10 Power Supply Recommendations

The devices are designed to operate from an input voltage supply range between 2.5V and 6V. The average input current of the TPS62097 is calculated as:

$$I_{IN} = \frac{1}{\eta} \times \frac{V_{OUT} \times I_{OUT}}{V_{IN}} \tag{6}$$

Ensure that a power supply has a sufficient current rating for the application.

## 11 PCB Layout

### 11.1 Layout Guidelines

- TI recommends to place all components as close as possible to the IC. Specially, the input capacitor placement must be closest to the PVIN and PGND pins of the device.
- The low side of the input and output capacitors must be connected directly to the PGND pin to avoid a ground potential shift.
- Use the input capacitor's terminals as the common node for AVIN and PVIN, AGND and PGND. It helps to reduce the noise coupling into the internal analog circuit blocks. Don't use a solid plane pour to connect these nodes.
- Use wide and short traces for the main current paths to reduce the parasitic inductance and resistance.
- The sense trace connected to VOS pin is a signal trace. Special care should be taken to avoid noise being induced. By a direct routing, parasitic inductance can be kept small. Keep the trace away from SW nodes.
- Refer to [Figure 32](#) for an example of component placement, routing and thermal design.

### 11.2 Layout Example

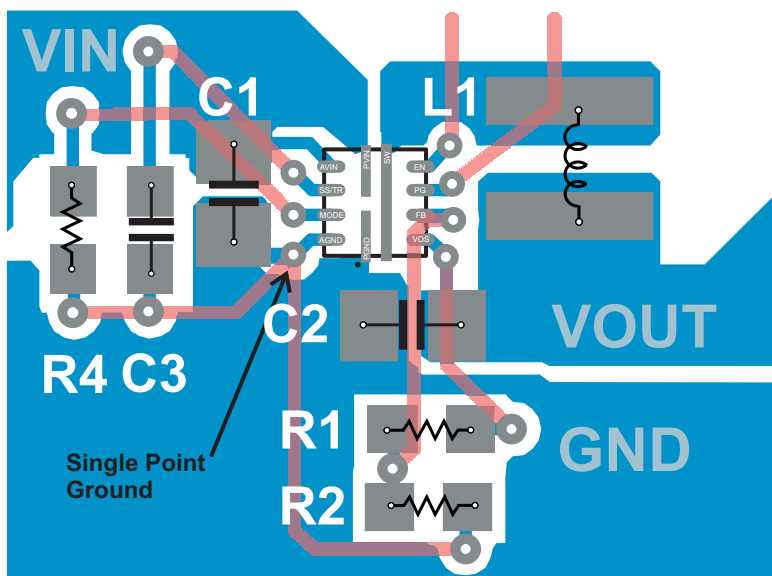


Figure 32. TPS62097 PCB Layout

### 11.3 Thermal Information

Implementation of integrated circuits in low-profile and fine pitch surface mount packages typically requires special attention to power dissipation. Many system dependent issues such as thermal coupling, airflow, added heat sinks and convection surfaces, and the presence of other heat-generating components affect the power-dissipation limits of a given component.

*Thermal Information* provides the thermal metric of the device on the TPS62097 EVM after considering the PCB design of real applications. The big copper planes connecting to the pads of the IC on the PCB board improve the thermal performance of the device. For more details on how to use the thermal parameters, see the application notes: Thermal Characteristics Application Notes [SZZA017](#) and [SPRA953](#).

## 12 Device and Documentation Support

### 12.1 Device Support

#### 12.1.1 Third-Party Products Disclaimer

TI'S PUBLICATION OF INFORMATION REGARDING THIRD-PARTY PRODUCTS OR SERVICES DOES NOT CONSTITUTE AN ENDORSEMENT REGARDING THE SUITABILITY OF SUCH PRODUCTS OR SERVICES OR A WARRANTY, REPRESENTATION OR ENDORSEMENT OF SUCH PRODUCTS OR SERVICES, EITHER ALONE OR IN COMBINATION WITH ANY TI PRODUCT OR SERVICE.

### 12.2 Community Resources

The following links connect to TI community resources. Linked contents are provided "AS IS" by the respective contributors. They do not constitute TI specifications and do not necessarily reflect TI's views; see TI's [Terms of Use](#).

**TI E2E™ Online Community** *TI's Engineer-to-Engineer (E2E) Community*. Created to foster collaboration among engineers. At [e2e.ti.com](http://e2e.ti.com), you can ask questions, share knowledge, explore ideas and help solve problems with fellow engineers.

**Design Support** *TI's Design Support* Quickly find helpful E2E forums along with design support tools and contact information for technical support.

### 12.3 Trademarks

E2E is a trademark of Texas Instruments.

### 12.4 Electrostatic Discharge Caution



These devices have limited built-in ESD protection. The leads should be shorted together or the device placed in conductive foam during storage or handling to prevent electrostatic damage to the MOS gates.

### 12.5 Glossary

[SLYZ022](#) — *TI Glossary*.

This glossary lists and explains terms, acronyms, and definitions.

## 13 Mechanical, Packaging, and Orderable Information

The following pages include mechanical, packaging, and orderable information. This information is the most current data available for the designated devices. This data is subject to change without notice and revision of this document. For browser-based versions of this data sheet, refer to the left-hand navigation.

## PACKAGING INFORMATION

Orderable Device	Status (1)	Package Type	Package Drawing	Pins	Package Qty	Eco Plan (2)	Lead/Ball Finish (6)	MSL Peak Temp (3)	Op Temp (°C)	Device Marking (4/5)	Samples
TPS6209718RWKR	ACTIVE	VQFN-HR	RWK	11	3000	Green (RoHS & no Sb/Br)	CU NIPDAU	Level-1-260C-UNLIM	-40 to 125	ZGB5	<a href="#">Samples</a>
TPS6209718RWKT	ACTIVE	VQFN-HR	RWK	11	250	Green (RoHS & no Sb/Br)	CU NIPDAU	Level-1-260C-UNLIM	-40 to 125	ZGB5	<a href="#">Samples</a>
TPS6209733RWKR	ACTIVE	VQFN-HR	RWK	11	3000	Green (RoHS & no Sb/Br)	CU NIPDAU	Level-1-260C-UNLIM	-40 to 125	ZGC5	<a href="#">Samples</a>
TPS6209733RWKT	ACTIVE	VQFN-HR	RWK	11	250	Green (RoHS & no Sb/Br)	CU NIPDAU	Level-1-260C-UNLIM	-40 to 125	ZGC5	<a href="#">Samples</a>
TPS62097RWKR	ACTIVE	VQFN-HR	RWK	11	3000	Green (RoHS & no Sb/Br)	CU NIPDAU	Level-1-260C-UNLIM	-40 to 125	ZFZ5	<a href="#">Samples</a>
TPS62097RWKT	ACTIVE	VQFN-HR	RWK	11	250	Green (RoHS & no Sb/Br)	CU NIPDAU	Level-1-260C-UNLIM	-40 to 125	ZFZ5	<a href="#">Samples</a>

(1) The marketing status values are defined as follows:

**ACTIVE:** Product device recommended for new designs.

**LIFEBUY:** TI has announced that the device will be discontinued, and a lifetime-buy period is in effect.

**NRND:** Not recommended for new designs. Device is in production to support existing customers, but TI does not recommend using this part in a new design.

**PREVIEW:** Device has been announced but is not in production. Samples may or may not be available.

**OBSOLETE:** TI has discontinued the production of the device.

(2) Eco Plan - The planned eco-friendly classification: Pb-Free (RoHS), Pb-Free (RoHS Exempt), or Green (RoHS & no Sb/Br) - please check <http://www.ti.com/productcontent> for the latest availability information and additional product content details.

**TBD:** The Pb-Free/Green conversion plan has not been defined.

**Pb-Free (RoHS):** TI's terms "Lead-Free" or "Pb-Free" mean semiconductor products that are compatible with the current RoHS requirements for all 6 substances, including the requirement that lead not exceed 0.1% by weight in homogeneous materials. Where designed to be soldered at high temperatures, TI Pb-Free products are suitable for use in specified lead-free processes.

**Pb-Free (RoHS Exempt):** This component has a RoHS exemption for either 1) lead-based flip-chip solder bumps used between the die and package, or 2) lead-based die adhesive used between the die and leadframe. The component is otherwise considered Pb-Free (RoHS compatible) as defined above.

**Green (RoHS & no Sb/Br):** TI defines "Green" to mean Pb-Free (RoHS compatible), and free of Bromine (Br) and Antimony (Sb) based flame retardants (Br or Sb do not exceed 0.1% by weight in homogeneous material)

(3) MSL, Peak Temp. - The Moisture Sensitivity Level rating according to the JEDEC industry standard classifications, and peak solder temperature.

(4) There may be additional marking, which relates to the logo, the lot trace code information, or the environmental category on the device.

(5) Multiple Device Markings will be inside parentheses. Only one Device Marking contained in parentheses and separated by a "~" will appear on a device. If a line is indented then it is a continuation of the previous line and the two combined represent the entire Device Marking for that device.

<sup>(6)</sup> Lead/Ball Finish - Orderable Devices may have multiple material finish options. Finish options are separated by a vertical ruled line. Lead/Ball Finish values may wrap to two lines if the finish value exceeds the maximum column width.

**Important Information and Disclaimer:** The information provided on this page represents TI's knowledge and belief as of the date that it is provided. TI bases its knowledge and belief on information provided by third parties, and makes no representation or warranty as to the accuracy of such information. Efforts are underway to better integrate information from third parties. TI has taken and continues to take reasonable steps to provide representative and accurate information but may not have conducted destructive testing or chemical analysis on incoming materials and chemicals. TI and TI suppliers consider certain information to be proprietary, and thus CAS numbers and other limited information may not be available for release.

In no event shall TI's liability arising out of such information exceed the total purchase price of the TI part(s) at issue in this document sold by TI to Customer on an annual basis.

**TAPE AND REEL INFORMATION**

**QUADRANT ASSIGNMENTS FOR PIN 1 ORIENTATION IN TAPE**

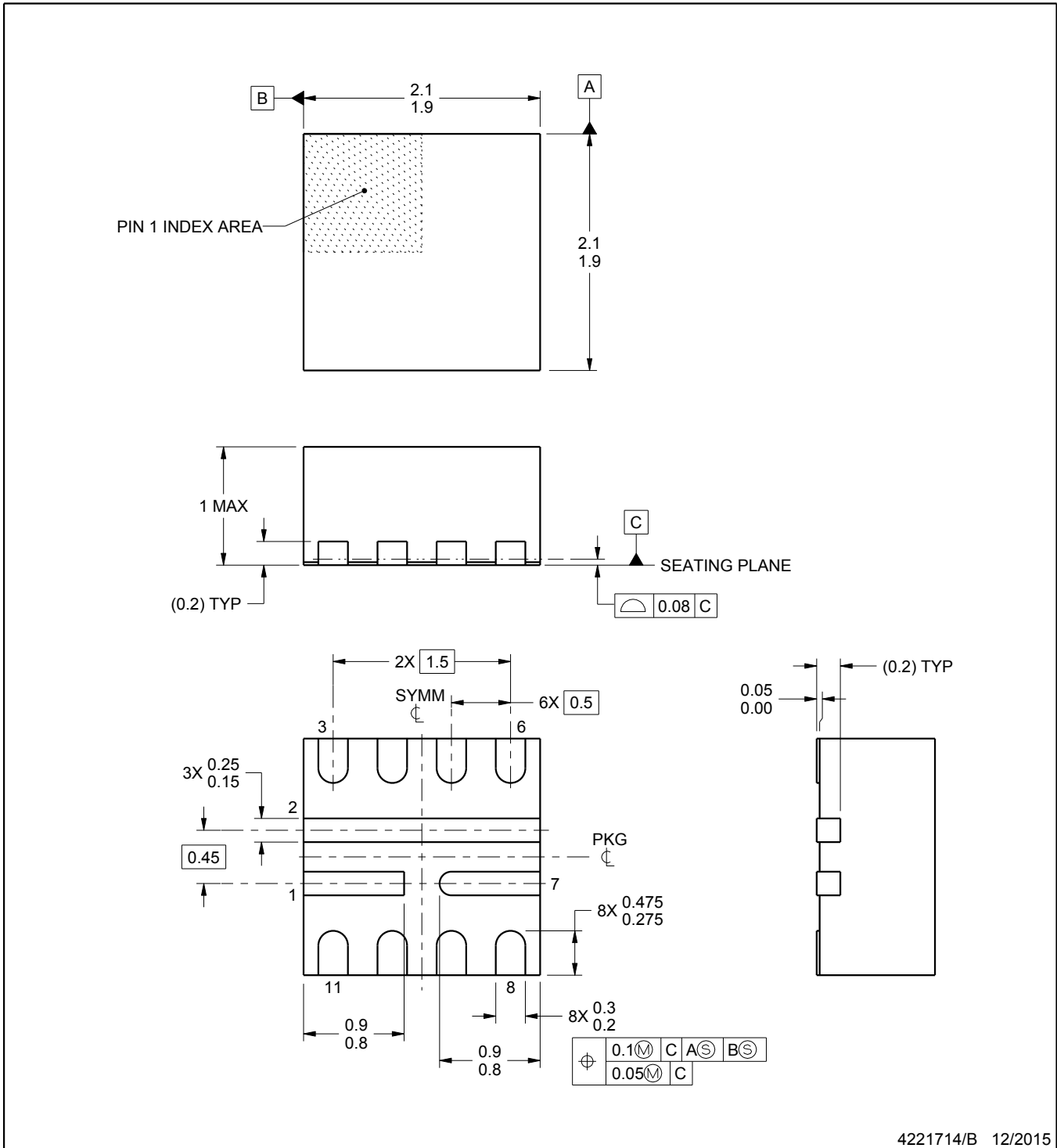

\*All dimensions are nominal

Device	Package Type	Package Drawing	Pins	SPQ	Reel Diameter (mm)	Reel Width W1 (mm)	A0 (mm)	B0 (mm)	K0 (mm)	P1 (mm)	W (mm)	Pin1 Quadrant
TPS6209718RWKR	VQFN-HR	RWK	11	3000	180.0	8.4	2.3	2.3	1.15	4.0	8.0	Q2
TPS6209733RWKR	VQFN-HR	RWK	11	3000	180.0	8.4	2.3	2.3	1.15	4.0	8.0	Q2

**TAPE AND REEL BOX DIMENSIONS**


\*All dimensions are nominal

Device	Package Type	Package Drawing	Pins	SPQ	Length (mm)	Width (mm)	Height (mm)
TPS6209718RWKR	VQFN-HR	RWK	11	3000	210.0	185.0	35.0
TPS6209733RWKR	VQFN-HR	RWK	11	3000	210.0	185.0	35.0



4221714/B 12/2015

NOTES:

1. All linear dimensions are in millimeters. Any dimensions in parenthesis are for reference only. Dimensioning and tolerancing per ASME Y14.5M.
2. This drawing is subject to change without notice.
3. Package pin numbers 1, 2, and 7 must be soldered to the printed circuit board for thermal and mechanical performance. Refer to product data sheet for specific thermal pad and via recommendations.

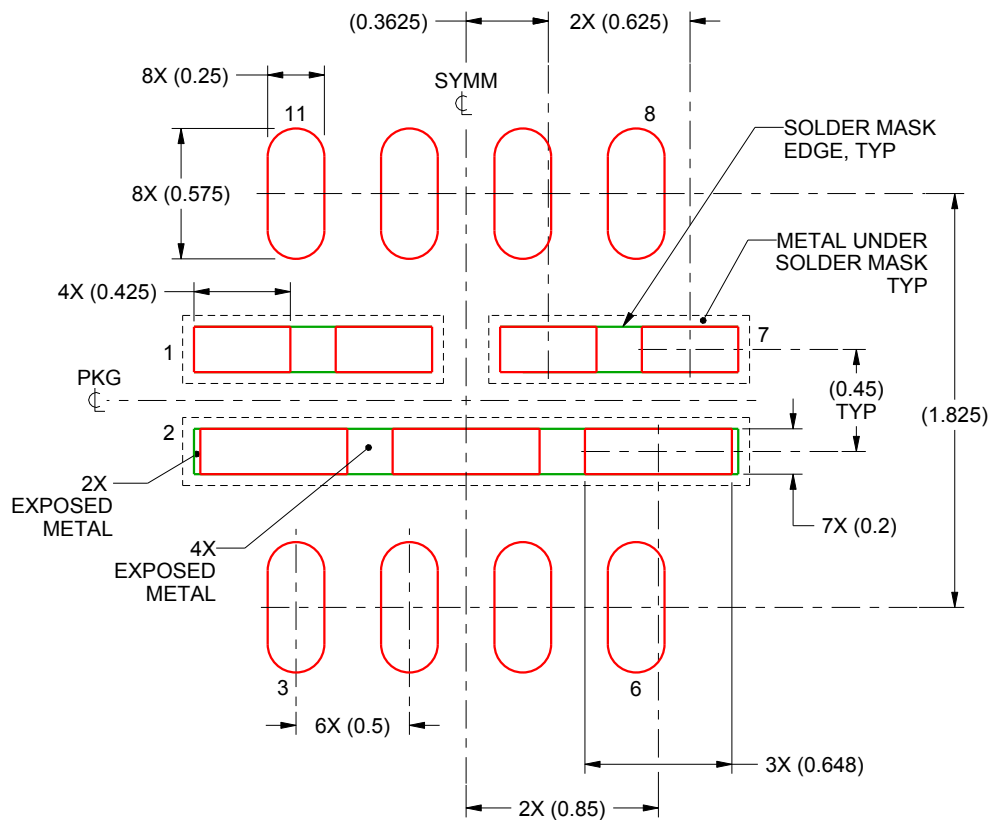


# EXAMPLE STENCIL DESIGN

RWK0011B

VQFN - 1 mm max height

PLASTIC QUAD FLATPACK - NO LEAD



SOLDER PASTE EXAMPLE  
BASED ON 0.1 mm THICK STENCIL

PADS 1,2 & 7  
81% PRINTED SOLDER COVERAGE BY AREA UNDER PACKAGE  
SCALE:30X

4221714/B 12/2015

NOTES: (continued)

6. Laser cutting apertures with trapezoidal walls and rounded corners may offer better paste release. IPC-7525 may have alternate design recommendations.

## IMPORTANT NOTICE

Texas Instruments Incorporated and its subsidiaries (TI) reserve the right to make corrections, enhancements, improvements and other changes to its semiconductor products and services per JESD46, latest issue, and to discontinue any product or service per JESD48, latest issue. Buyers should obtain the latest relevant information before placing orders and should verify that such information is current and complete. All semiconductor products (also referred to herein as "components") are sold subject to TI's terms and conditions of sale supplied at the time of order acknowledgment.

TI warrants performance of its components to the specifications applicable at the time of sale, in accordance with the warranty in TI's terms and conditions of sale of semiconductor products. Testing and other quality control techniques are used to the extent TI deems necessary to support this warranty. Except where mandated by applicable law, testing of all parameters of each component is not necessarily performed.

TI assumes no liability for applications assistance or the design of Buyers' products. Buyers are responsible for their products and applications using TI components. To minimize the risks associated with Buyers' products and applications, Buyers should provide adequate design and operating safeguards.

TI does not warrant or represent that any license, either express or implied, is granted under any patent right, copyright, mask work right, or other intellectual property right relating to any combination, machine, or process in which TI components or services are used. Information published by TI regarding third-party products or services does not constitute a license to use such products or services or a warranty or endorsement thereof. Use of such information may require a license from a third party under the patents or other intellectual property of the third party, or a license from TI under the patents or other intellectual property of TI.

Reproduction of significant portions of TI information in TI data books or data sheets is permissible only if reproduction is without alteration and is accompanied by all associated warranties, conditions, limitations, and notices. TI is not responsible or liable for such altered documentation. Information of third parties may be subject to additional restrictions.

Resale of TI components or services with statements different from or beyond the parameters stated by TI for that component or service voids all express and any implied warranties for the associated TI component or service and is an unfair and deceptive business practice. TI is not responsible or liable for any such statements.

Buyer acknowledges and agrees that it is solely responsible for compliance with all legal, regulatory and safety-related requirements concerning its products, and any use of TI components in its applications, notwithstanding any applications-related information or support that may be provided by TI. Buyer represents and agrees that it has all the necessary expertise to create and implement safeguards which anticipate dangerous consequences of failures, monitor failures and their consequences, lessen the likelihood of failures that might cause harm and take appropriate remedial actions. Buyer will fully indemnify TI and its representatives against any damages arising out of the use of any TI components in safety-critical applications.

In some cases, TI components may be promoted specifically to facilitate safety-related applications. With such components, TI's goal is to help enable customers to design and create their own end-product solutions that meet applicable functional safety standards and requirements. Nonetheless, such components are subject to these terms.

No TI components are authorized for use in FDA Class III (or similar life-critical medical equipment) unless authorized officers of the parties have executed a special agreement specifically governing such use.

Only those TI components which TI has specifically designated as military grade or "enhanced plastic" are designed and intended for use in military/aerospace applications or environments. Buyer acknowledges and agrees that any military or aerospace use of TI components which have **not** been so designated is solely at the Buyer's risk, and that Buyer is solely responsible for compliance with all legal and regulatory requirements in connection with such use.

TI has specifically designated certain components as meeting ISO/TS16949 requirements, mainly for automotive use. In any case of use of non-designated products, TI will not be responsible for any failure to meet ISO/TS16949.

### Products

Audio	<a href="http://www.ti.com/audio">www.ti.com/audio</a>
Amplifiers	<a href="http://amplifier.ti.com">amplifier.ti.com</a>
Data Converters	<a href="http://dataconverter.ti.com">dataconverter.ti.com</a>
DLP® Products	<a href="http://www.dlp.com">www.dlp.com</a>
DSP	<a href="http://dsp.ti.com">dsp.ti.com</a>
Clocks and Timers	<a href="http://www.ti.com/clocks">www.ti.com/clocks</a>
Interface	<a href="http://interface.ti.com">interface.ti.com</a>
Logic	<a href="http://logic.ti.com">logic.ti.com</a>
Power Mgmt	<a href="http://power.ti.com">power.ti.com</a>
Microcontrollers	<a href="http://microcontroller.ti.com">microcontroller.ti.com</a>
RFID	<a href="http://www.ti-rfid.com">www.ti-rfid.com</a>
OMAP Applications Processors	<a href="http://www.ti.com/omap">www.ti.com/omap</a>
Wireless Connectivity	<a href="http://www.ti.com/wirelessconnectivity">www.ti.com/wirelessconnectivity</a>

### Applications

Automotive and Transportation	<a href="http://www.ti.com/automotive">www.ti.com/automotive</a>
Communications and Telecom	<a href="http://www.ti.com/communications">www.ti.com/communications</a>
Computers and Peripherals	<a href="http://www.ti.com/computers">www.ti.com/computers</a>
Consumer Electronics	<a href="http://www.ti.com/consumer-apps">www.ti.com/consumer-apps</a>
Energy and Lighting	<a href="http://www.ti.com/energy">www.ti.com/energy</a>
Industrial	<a href="http://www.ti.com/industrial">www.ti.com/industrial</a>
Medical	<a href="http://www.ti.com/medical">www.ti.com/medical</a>
Security	<a href="http://www.ti.com/security">www.ti.com/security</a>
Space, Avionics and Defense	<a href="http://www.ti.com/space-avionics-defense">www.ti.com/space-avionics-defense</a>
Video and Imaging	<a href="http://www.ti.com/video">www.ti.com/video</a>

### TI E2E Community

[e2e.ti.com](http://e2e.ti.com)