

NOTES
 1. SEE SHEETS 2 TO 7 FOR ALL UNSPECIFIED NOTES, DIMENSIONS AND PART NUMBERS

THIS DRAWING CONTAINS INFORMATION THAT IS PROPRIETARY TO MOLEX ELECTRONIC TECHNOLOGIES, LLC AND SHOULD NOT BE USED WITHOUT WRITTEN PERMISSION												
QUALITY SYMBOLS ▽A = 0 ▽E = 0 ▽F = 0 ▼ = 0 ▽C = 0 ⊗ = 0 ■ = 0 ▽ = 0	PROPOSED EC NO: 102420 DRWN: JFLETCHER CHK'D: NDOWDS APPR: JDWALLACE	GENERAL TOLERANCES (UNLESS SPECIFIED)		DIMENSION UNITS	SCALE							
		ANGULAR TOL ± 2.0 °		MM	1.5:1							
		4 PLACES ±	DRWN BY		DATE		4CCT ML-XT CV CONNECTOR					
		3 PLACES ±	JFLETCHER		2015/11/02							
		2 PLACES ± 0.1	CHK'D BY		DATE		PRODUCT CUSTOMER DRAWING					
		1 PLACE ± 0.2	NDOWDS		2015/11/10							
		0 PLACES ±	APPR BY		DATE		SERIES MATERIAL NUMBER CUSTOMER 93443 SEE CHART GENERAL MARKET					
		DRAFT WHERE APPLICABLE MUST REMAIN WITHIN DIMENSIONS	JDWALLACE		2015/11/16							
				DRAWING SIZE	THIRD ANGLE PROJECTION		DOCUMENT NUMBER		DOC TYPE	DOC PART	SHEET NUMBER	
				A3			934430030		PSD	000	1 OF 9	

4CCT RECEPTACLE CONNECTOR

4CCT RECEPTACLE CONNECTOR WITH HEATSHRINK HOUSING ULTRASONICALLY WELDED IN PLACE

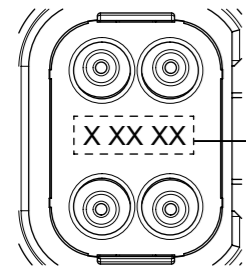
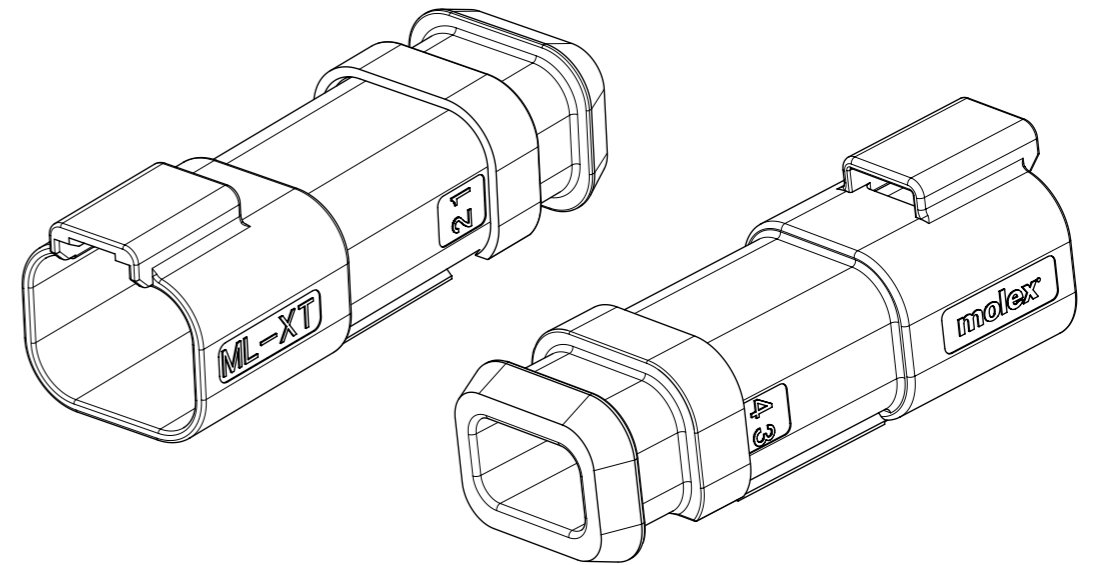
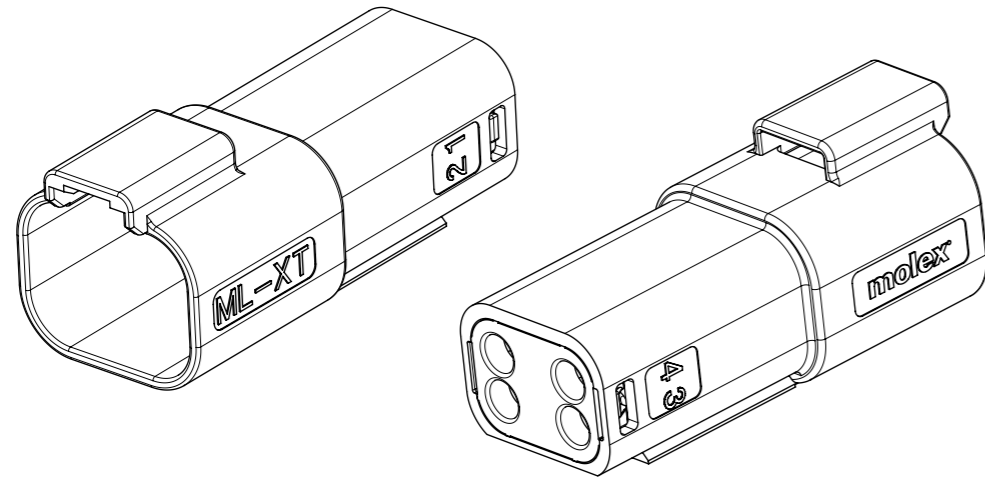

DATE CODE: X XX XX
 X — DAY: 1-7
 X — WEEK: 01 - 52
 X — YEAR: 00 - 99
 X —
 EXAMPLE: 11315 = DAY 1, WEEK 13, YEAR 15
 i.e. 23rd OF MARCH 2015

DETAIL A
 SCALE 2:1

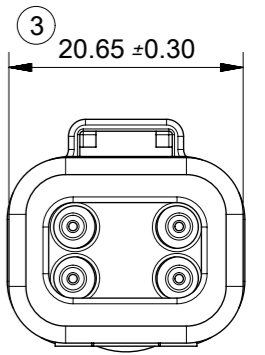
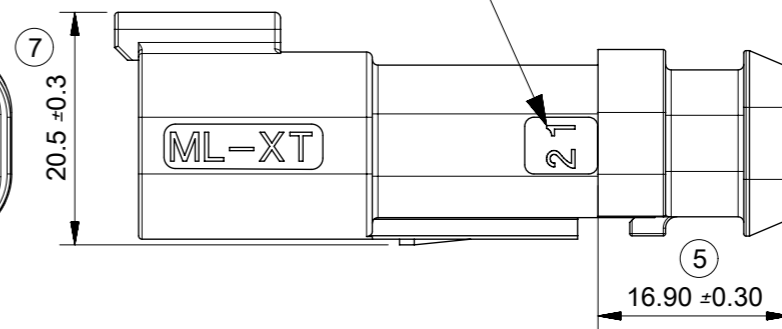
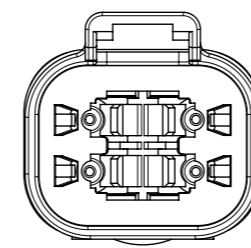
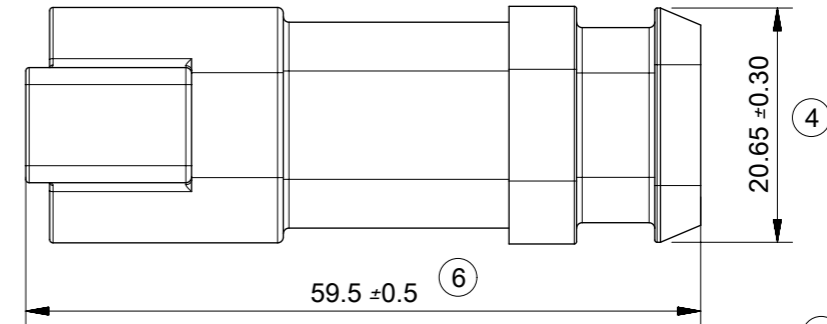
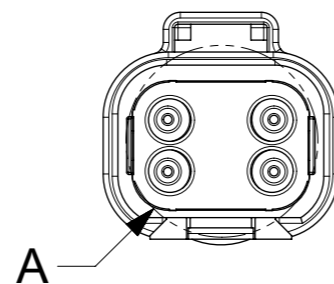
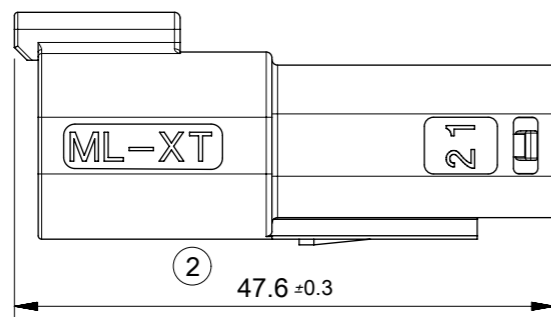
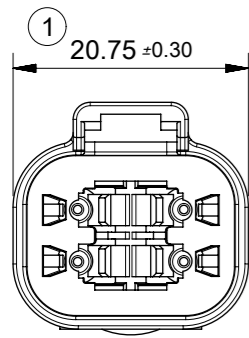

NOTE 2

1. MATERIAL
 HOUSING: NYLON 30%GF
 BACK SEAL: HIGH CONSISTENCY RUBBER
2. CIRCUIT IDENTIFICATION
3. JACKET RANGE LARGE = Ø2.7MM TO 3.6MM (SEAL COLOUR: LIGHT BLUE)
 JACKET RANGE SMALL = Ø1.4MM TO 2.7MM (SEAL COLOUR: BURNT ORANGE)
4. SEE SHEET 3 FOR FINAL PART NUMBER
5. SEE 934430010 PS P FOR PRODUCT SPECIFICATION
6. SEE 934430002 PS K OR 934430010 PS K FOR PACKAGING SPECIFICATION
- INSPECTION NUMBERS 1 - 50 RESERVED FOR SHEET 2
- LAST INSPECTION NO. 7

THIS DRAWING CONTAINS INFORMATION THAT IS PROPRIETARY TO MOLEX ELECTRONIC TECHNOLOGIES, LLC AND SHOULD NOT BE USED WITHOUT WRITTEN PERMISSION											
QUALITY SYMBOLS		GENERAL TOLERANCES (UNLESS SPECIFIED)				DIMENSION UNITS		SCALE			
▽A = 0	▽E = 0	ANGULAR TOL ± 2.0 °				MM		1.5:1			
▽F = 0	▽G = 0	4 PLACES ±		DRWN BY		DATE		4CCT ML-XT CV CONNECTOR			
▽H = 0	▽I = 0	3 PLACES ±		JFLETCHER		2015/11/02					
▽J = 0	▽K = 0	2 PLACES ± 0.1		CHK'D BY		DATE		PRODUCT CUSTOMER DRAWING			
▽L = 0	▽M = 0	1 PLACE ± 0.2		NDOWDS		2015/11/10					
▽N = 0	▽O = 0	0 PLACES ±		APPR BY		DATE		SERIES: 93443 MATERIAL NUMBER: SEE CHART CUSTOMER: GENERAL MARKET			
▽P = 0	▽Q = 0	DRAFT WHERE APPLICABLE MUST REMAIN WITHIN DIMENSIONS		JDWALLACE		2015/11/16					
▽R = 0	▽S = 0	A3		DRAWING SIZE		THIRD ANGLE PROJECTION		DOCUMENT NUMBER: 934430030 DOC TYPE: PSD DOC PART: 000 SHEET NUMBER: 2 OF 9			
▽T = 0	▽U = 0	A1		A3							

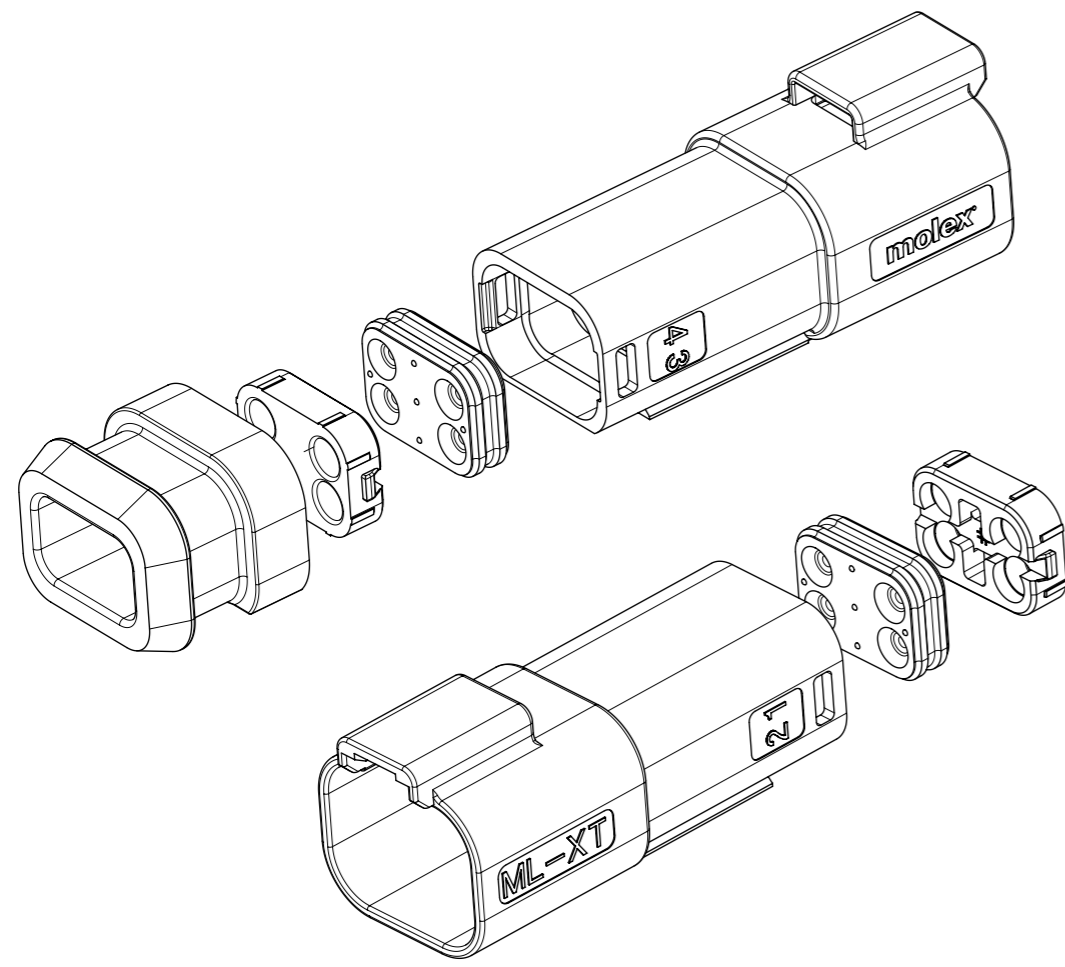

4CCT RECEPTACLE CONNECTOR

SERIES No. 93444

CIRCUIT SIZE
3 = 4CCT

ASSEMBLY OPTIONS:
 1 = RECEP ASSEMBLY FOR WIRE JACKET RANGE: Ø1.4mm-2.7mm (NOTE 2)
 2 = RECEP ASSEMBLY FOR WIRE JACKET RANGE: Ø2.7mm-3.6mm (NOTE 2)
 5 = RECEP ASSEMBLY & HEATSHRINK FOR WIRE JACKET RANGE: Ø1.4mm-2.7mm
 6 = RECEP ASSEMBLY & HEATSHRINK FOR WIRE JACKET RANGE: Ø2.7mm-3.6mm

COLOUR
 01=BLACK 06=WHITE
 02=GREY 07=BROWN
 03=GREEN 08=ORANGE
 04=BLUE 09=RED

EXAMPLE:
 4cct RECEP BLACK WITH LARGE SEAL AND HEATSHRINK = 93444-3601

NOTES

1. SEE SHEET 2 FOR UNSPECIFIED NOTES AND DIMENSIONS
2. BACK COVER HOUSING COLOUR BLACK
3. HEATSHRINK HOUSING COLOUR BLACK

QUALITY SYMBOLS ▽A = 0 ▽E = 0 ▽F = 0 ▼ = 0 ▽C = 0 ⊗ = 0 ■ = 0 ▽ = 0	THIS DRAWING CONTAINS INFORMATION THAT IS PROPRIETARY TO MOLEX ELECTRONIC TECHNOLOGIES, LLC AND SHOULD NOT BE USED WITHOUT WRITTEN PERMISSION											
	PROPOSED EC NO: 102420 DRWN: JFLETCHER CHK'D: NDOWDS APPR: JDWALLACE	GENERAL TOLERANCES (UNLESS SPECIFIED)		DIMENSION UNITS	SCALE	 4CCT ML-XT CV CONNECTOR						
		ANGULAR TOL ± 2.0 °		MM	1:1							
		4 PLACES ±	DRWN BY		DATE		PRODUCT CUSTOMER DRAWING SERIES: 93443 MATERIAL NUMBER: SEE CHART CUSTOMER: GENERAL MARKET DOCUMENT NUMBER: 934430030 DOC TYPE: PSD DOC PART: 000 SHEET NUMBER: 3 OF 9					
		3 PLACES ±	JFLETCHER		2015/11/02							
		2 PLACES ± 0.1	CHK'D BY		DATE							
	1 PLACE ± 0.2	NDOWDS		2015/11/10		DRAFT WHERE APPLICABLE MUST REMAIN WITHIN DIMENSIONS						
	0 PLACES ±	APPR BY		DATE								
	DRAFT WHERE APPLICABLE MUST REMAIN WITHIN DIMENSIONS		JDWALLACE		2015/11/16		DRAWING SIZE		THIRD ANGLE PROJECTION			
			A3									

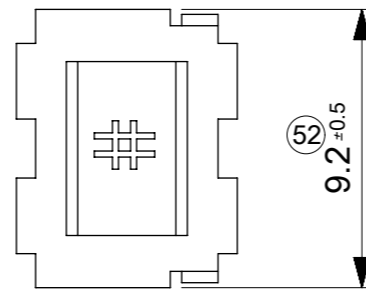
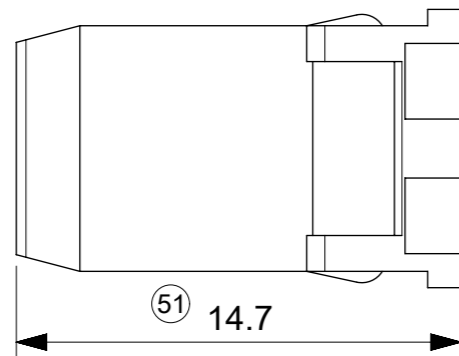
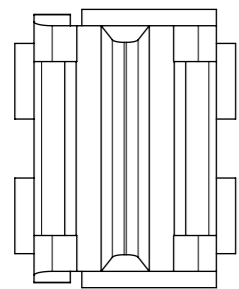
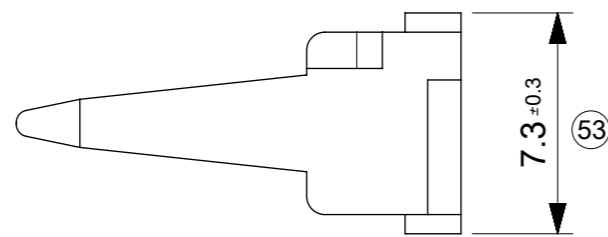
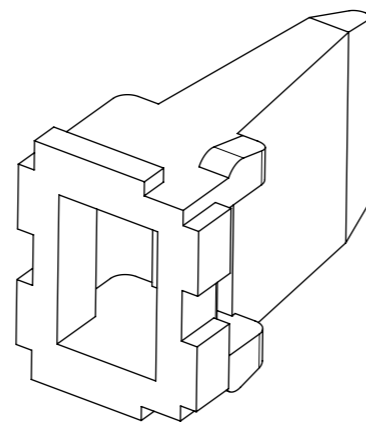
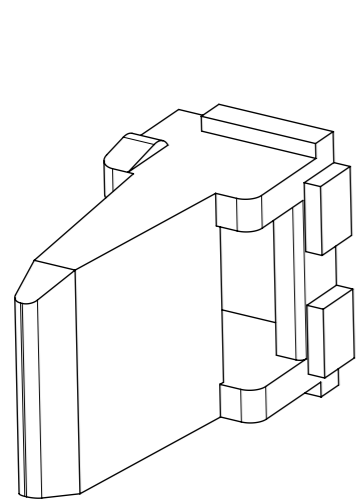

4CCT RECEP. WEDGELOCK

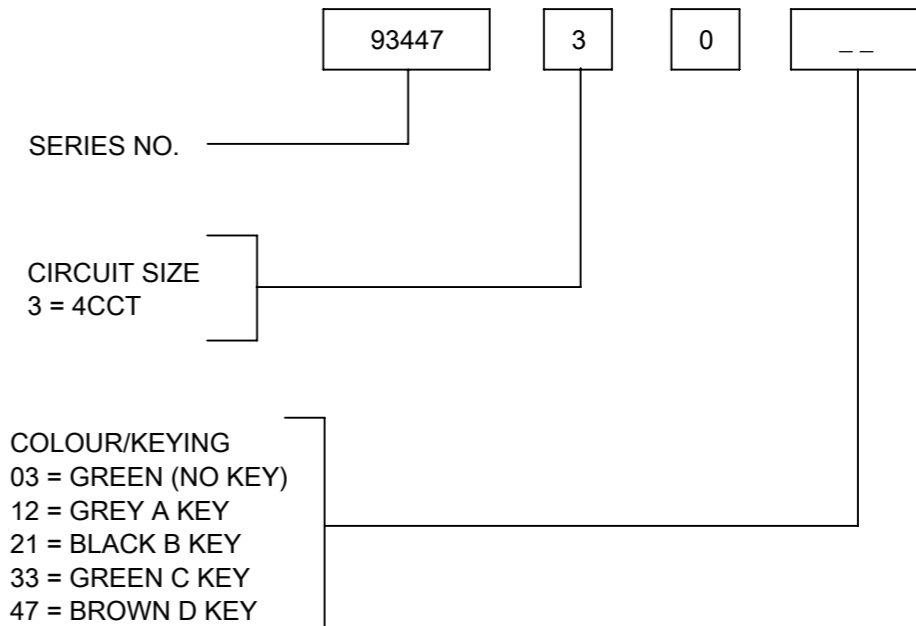

NOTES

1. MATERIAL
HOUSING: NYLON 30%GF
2. INSPECTION NUMBERS 51-100
RESERVED FOR SHEET 4
3. PART NUMBER 934473003 SHOWN
LAST INSPECTION NUMBER 53

THIS DRAWING CONTAINS INFORMATION THAT IS PROPRIETARY TO MOLEX ELECTRONIC TECHNOLOGIES, LLC AND SHOULD NOT BE USED WITHOUT WRITTEN PERMISSION											
QUALITY SYMBOLS ▽A = 0 ▽E = 0 ▽F = 0 ▼ = 0 ▽C = 0 ⊗ = 0 ■ = 0 ▽ = 0	PROPOSED EC NO: 102420 DRWN: JFLETCHER CHK'D: NDOWDS APPR: JDWALLACE	GENERAL TOLERANCES (UNLESS SPECIFIED)		DIMENSION UNITS	SCALE						
		ANGULAR TOL ± 2.0 °		MM	1.5:1						
		4 PLACES ±		DRWN BY	DATE						
		3 PLACES ±		JFLETCHER	2015/11/02	4CCT ML-XT CV CONNECTOR					
		2 PLACES ± 0.1		CHK'D BY	DATE						
		1 PLACE ± 0.2		NDOWDS	2015/11/10						
		0 PLACES ±		APPR BY	DATE	PRODUCT CUSTOMER DRAWING					
		DRAFT WHERE APPLICABLE MUST REMAIN WITHIN DIMENSIONS		JDWALLACE	2015/11/16						
				DRAWING SIZE	THIRD ANGLE PROJECTION						
				A3		SERIES	MATERIAL NUMBER	CUSTOMER			
		A1		93443	SEE CHART	GENERAL MARKET					
		REV		DOCUMENT NUMBER	DOC TYPE	DOC PART	SHEET NUMBER				
				934430030	PSD	000	4 OF 9				

934473012 (KEY A)
COLOUR GREY

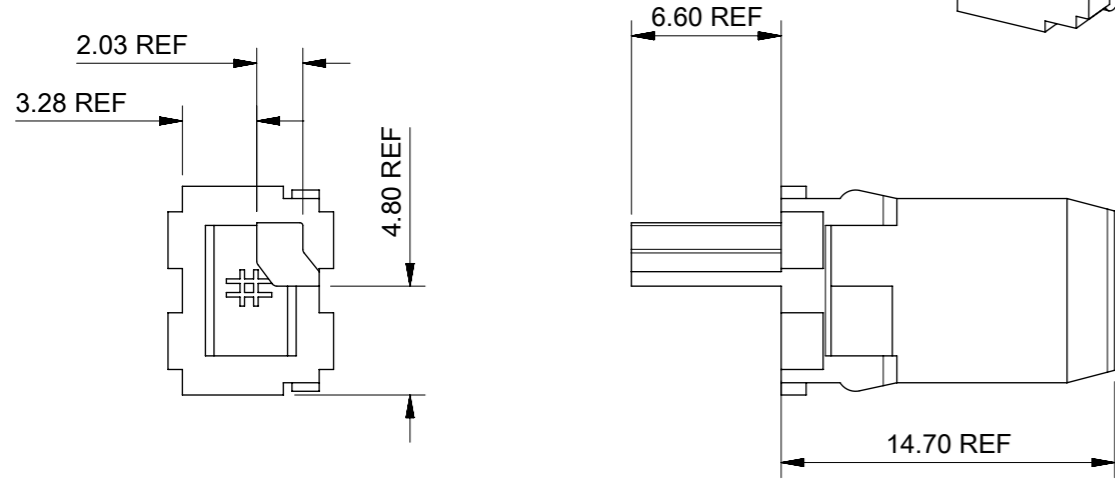

934473021 (KEY B)
COLOUR BLACK

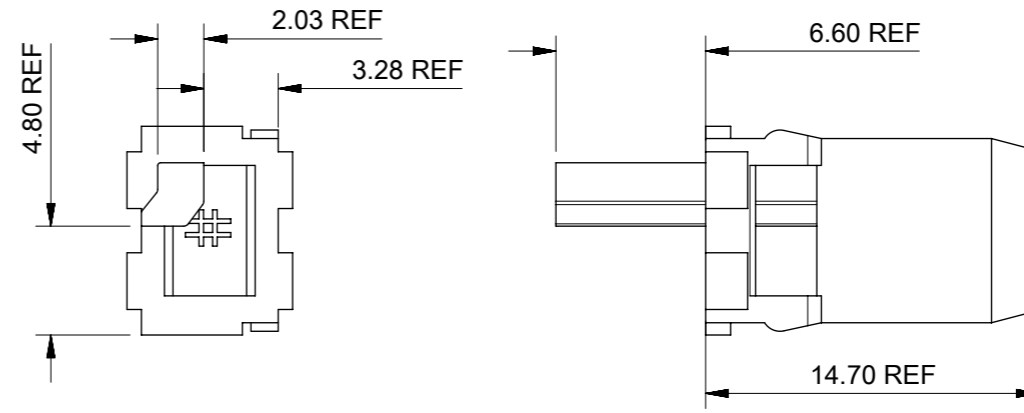

934473033 (KEY C)
COLOUR GREEN

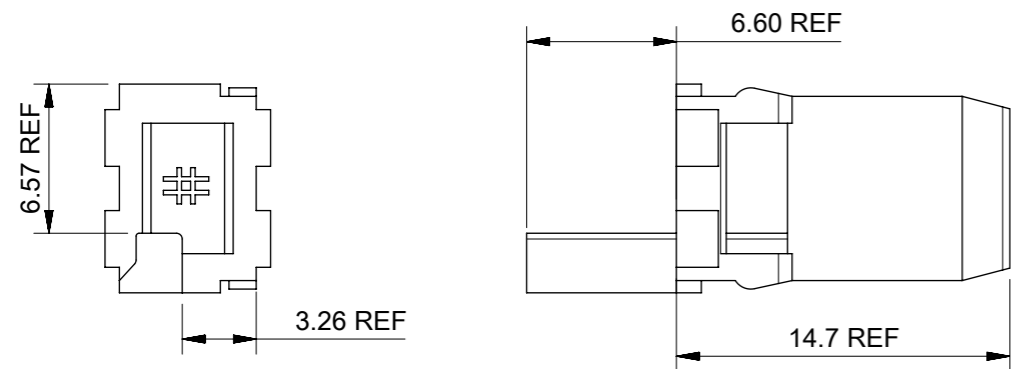

934473047 (KEY D)
COLOUR BROWN

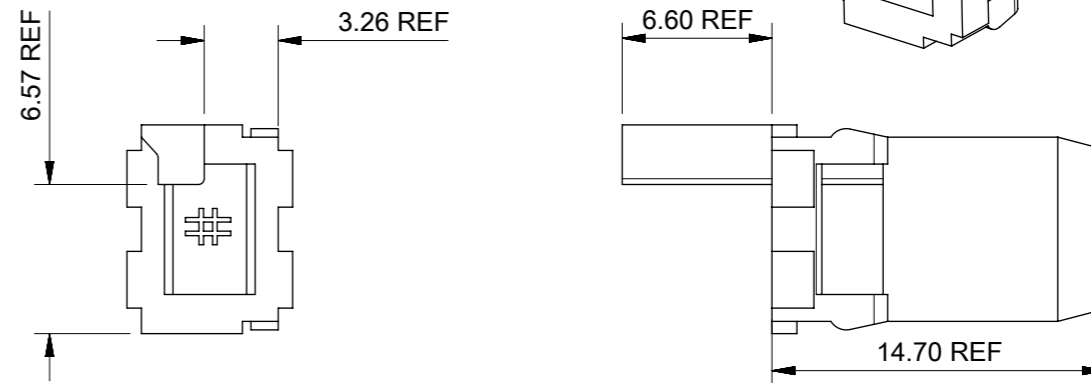

NOTES:
1. MATERIAL PA66 30%GF
2. SEE SHEET 4 FOR UNSPECIFIED NOTES & DIMENSIONS

THIS DRAWING CONTAINS INFORMATION THAT IS PROPRIETARY TO MOLEX ELECTRONIC TECHNOLOGIES, LLC AND SHOULD NOT BE USED WITHOUT WRITTEN PERMISSION												
QUALITY SYMBOLS		PROPOSED			GENERAL TOLERANCES (UNLESS SPECIFIED)		DIMENSION UNITS		SCALE			
▽A	= 0	2016/01/07	2016/01/11	2016/01/14	ANGULAR TOL ± 2.0 °		MM	3:1		<p>4CCT ML-XT CV CONNECTOR</p>		
▽E	= 0	EC NO: 102420 DRWN: JFLETCHER CHK'D: NDOWDS APPR: JDWALLACE	4 PLACES ±		DRWN BY		DATE		JFLETCHER 2015/11/02			
▽F	= 0		3 PLACES ±		CHK'D BY		DATE		NDOWDS 2015/11/10			
▽	= 0		2 PLACES ± 0.1		APPR BY		DATE		JDWALLACE 2015/11/16			
▽	= 0		1 PLACE ± 0.2		DRAFT WHERE APPLICABLE MUST REMAIN WITHIN DIMENSIONS		DRAWING SIZE		THIRD ANGLE PROJECTION		PRODUCT CUSTOMER DRAWING SERIES: 93443 MATERIAL NUMBER: CUSTOMER: GENERAL MARKET	
▽	= 0	0 PLACES ±		A3		A3				DOCUMENT NUMBER: 934430030 DOC TYPE: PSD DOC PART: 000 SHEET NUMBER: 5 OF 9		
▽	= 0	A1		REV		A3						

4CCT PLUG CONNECTOR

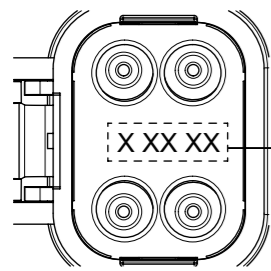
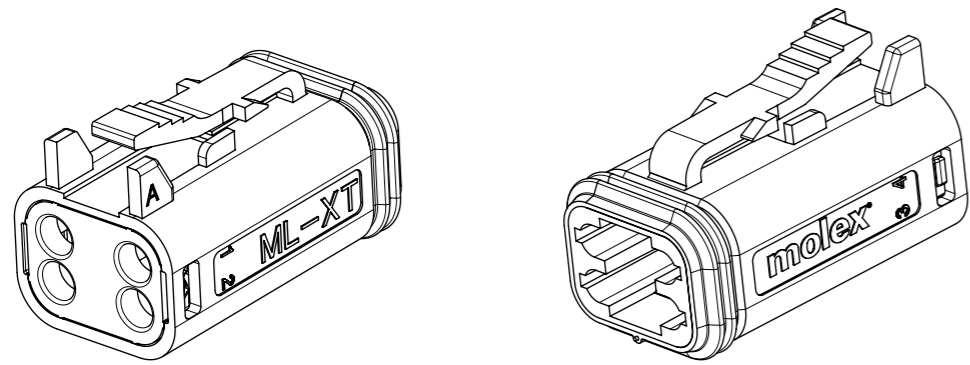

DETAIL B
SCALE 2:1

DATE CODE: X XX XX
X — DAY: 1-7

X — WEEK: 01 - 52

X — YEAR: 00 - 99

EXAMPLE: 11315 = DAY 1, WEEK 13, YEAR 15
i.e. 23rd OF MARCH 2015

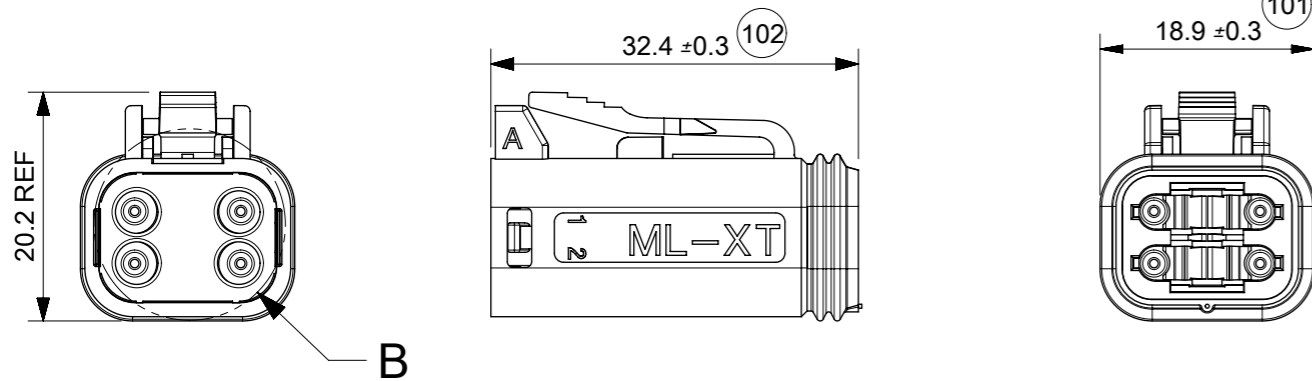

4CCT PLUG CONNECTOR WITH
HEATSHRINK HOUSING ULTRASONICALLY
WELDED IN PLACE

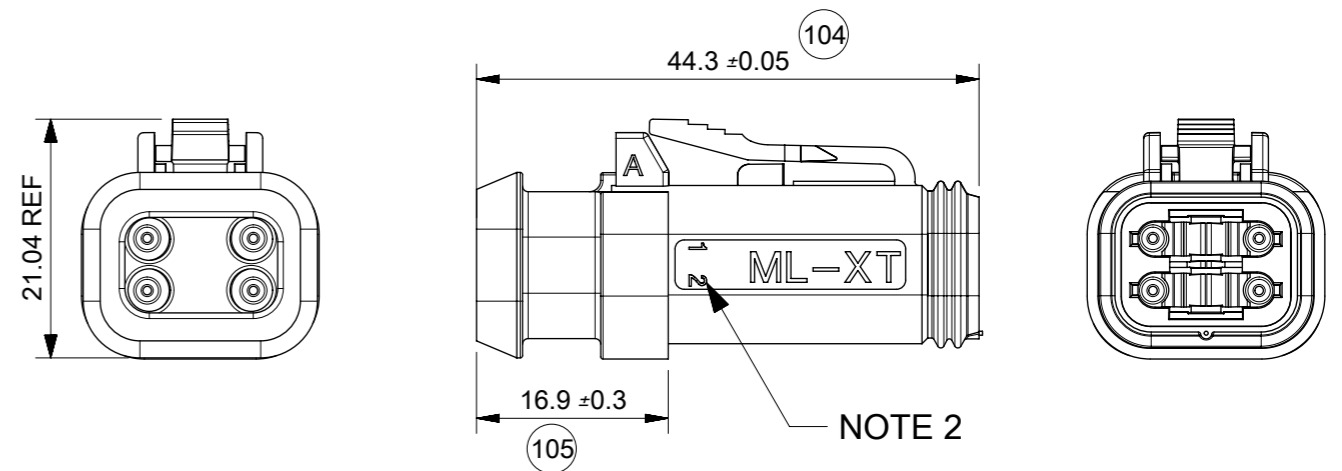
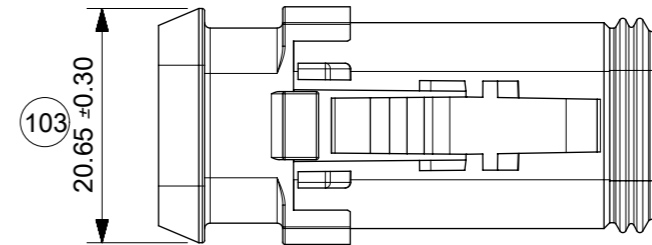
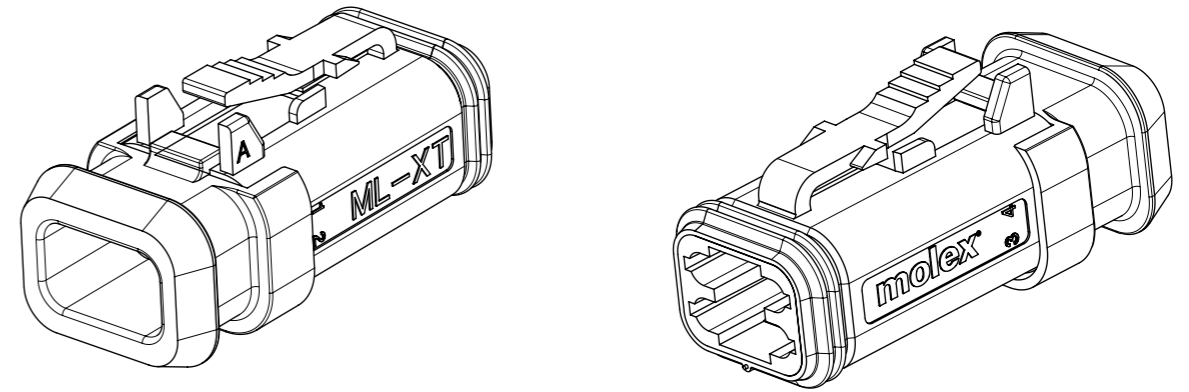

NOTES

- MATERIAL:
HOUSING: NYLON 30% GF
PLUG SEAL: SILICONE RUBBER
BACK SEAL: HIGH CONSISTENCY RUBBER
- CIRCUIT IDENTIFICATION
- JACKET RANGE LARGE = Ø2.7MM TO 3.6MM (SEAL COLOUR: LIGHT BLUE)
JACKET RANGE SMALL = Ø1.4MM TO 2.7MM (SEAL COLOUR: BURNT ORANGE)
- SEE SHEET 7 FOR FINAL PART NUMBER DESIGNATION
INSPECTION NUMBERS 101-150 RESERVED FOR SHEET 6
LAST INSPECTION NUMBER 105

<p>QUALITY SYMBOLS</p> <p>▽A = 0</p> <p>▽E = 0</p> <p>▽F = 0</p> <p>▽ = 0</p> <p>▽C = 0</p> <p>⊗ = 0</p> <p>■ = 0</p> <p>▽ = 0</p>	THIS DRAWING CONTAINS INFORMATION THAT IS PROPRIETARY TO MOLEX ELECTRONIC TECHNOLOGIES, LLC AND SHOULD NOT BE USED WITHOUT WRITTEN PERMISSION												
	<p>PROPOSED</p> <p>EC NO: 102420</p> <p>DRWN: JFLETCHER</p> <p>CHK'D: NDOWDS</p> <p>APPR: JDWALLACE</p>	2016/01/07		2016/01/11		2016/01/14		GENERAL TOLERANCES (UNLESS SPECIFIED)		DIMENSION UNITS	SCALE		
		ANGULAR TOL ± 2.0 °						MM	1:1	<p>4CCT ML-XT CV CONNECTOR</p> <p>PRODUCT CUSTOMER DRAWING</p>			
		4 PLACES	±	JFLETCHER		DATE		2015/11/02					
		3 PLACES	±	CHK'D BY		DATE		NDOWDS 2015/11/10					
		2 PLACES	± 0.1	APPR BY		DATE		JDWALLACE 2015/11/16					
	1 PLACE	± 0.2	DRAWING SIZE		THIRD ANGLE PROJECTION		A3						
	0 PLACES	±	DRAFT WHERE APPLICABLE MUST REMAIN WITHIN DIMENSIONS										
	SERIES			MATERIAL NUMBER			CUSTOMER						
	93443			SEE CHART			GENERAL MARKET						
DOCUMENT NUMBER						DOC TYPE		DOC PART		SHEET NUMBER			
934430030						PSD		000		6 OF 9			

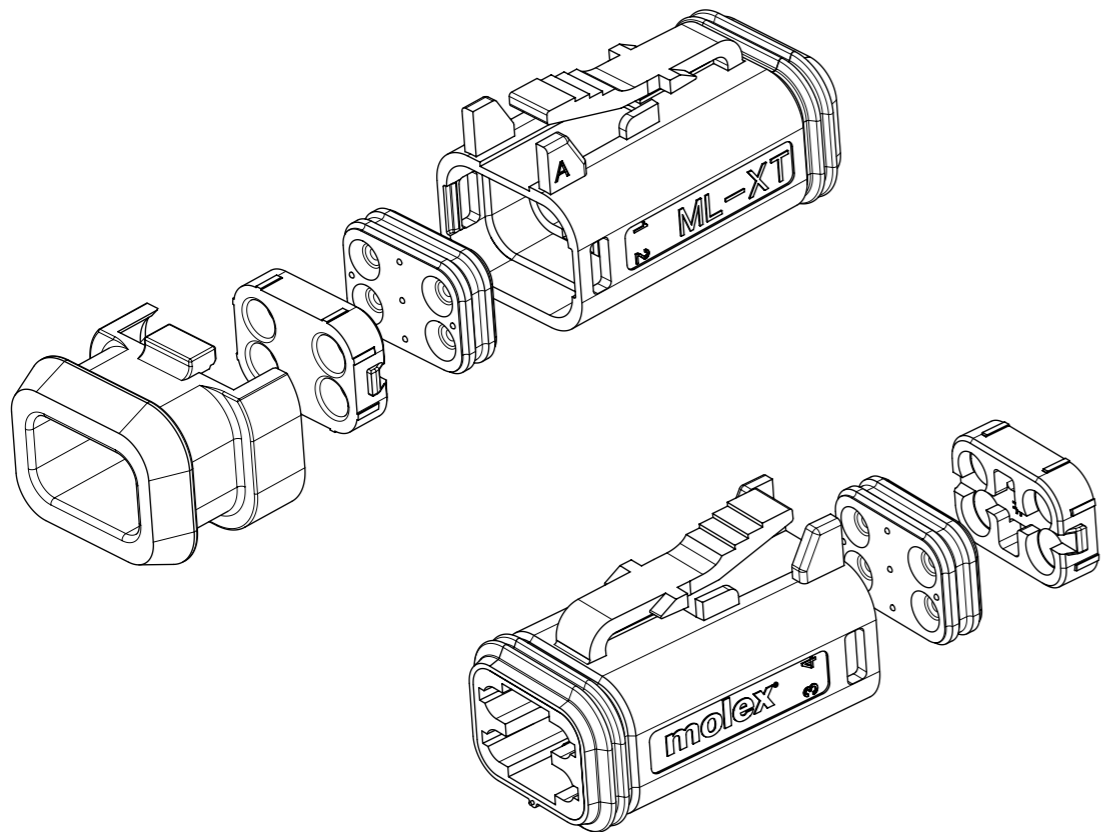

4CCT PLUG CONNECTOR

93445

3

-

--

SERIES No. _____

CIRCUIT SIZE
3 = 4CCT

ASSEMBLY OPTIONS:

- 1 = PLUG ASSEMBLY FOR WIRE JACKET RANGE: Ø1.4mm-2.7mm (NOTE 2)
- 2 = PLUG ASSEMBLY FOR WIRE JACKET RANGE: Ø2.7mm-3.6mm (NOTE 2)
- 5 = PLUG ASSEMBLY & HEATSHRINK FOR WIRE JACKET RANGE: Ø1.4mm-2.7mm
- 6 = PLUG ASSEMBLY & HEATSHRINK FOR WIRE JACKET RANGE: Ø2.7mm-3.6mm

COLOUR

- 01=BLACK
- 02=GREY 06=WHITE
- 03=GREEN 07=BROWN
- 04=BLUE 08=ORANGE
- 05=YELLOW 09=RED

EXAMPLE:

4cct PLUG BLACK WITH LARGE SEAL AND HEATSHRINK = 93444-3601

NOTES

- 1. SEE SHEET 6 FOR UNSPECIFIED NOTES AND DIMENSIONS
- 2. BACK COVER HOUSING COLOUR BLACK
- 3. HEATSHRINK HOUSING COLOUR BLACK

THIS DRAWING CONTAINS INFORMATION THAT IS PROPRIETARY TO MOLEX ELECTRONIC TECHNOLOGIES, LLC AND SHOULD NOT BE USED WITHOUT WRITTEN PERMISSION														
QUALITY SYMBOLS ▽A = 0 ▽E = 0 ▽F = 0 ▽B = 0 ▽C = 0 ▽D = 0 ▽G = 0 ▽H = 0 ▽I = 0	PROPOSED EC NO: 102420 DRWN: JFLETCHER CHK'D: NDOWDS APPR: JDWALLACE	GENERAL TOLERANCES (UNLESS SPECIFIED)		DIMENSION UNITS	SCALE									
		ANGULAR TOL ± 2.0 °		MM	1:1									
		4 PLACES ±		DRWN BY	DATE									
		3 PLACES ±		JFLETCHER	2015/11/02	CHK'D BY		DATE	4CCT ML-XT CV CONNECTOR					
		2 PLACES ± 0.1		NDOWDS	2015/11/10	APPR BY		DATE						
		1 PLACE ± 0.2		JDWALLACE	2015/11/16	DRAWING SIZE		THIRD ANGLE PROJECTION	PRODUCT CUSTOMER DRAWING					
		0 PLACES ±		DRAFT WHERE APPLICABLE MUST REMAIN WITHIN DIMENSIONS		A3								
										SERIES	MATERIAL NUMBER	CUSTOMER		
										93443	SEE CHART	GENERAL MARKET		
										DOCUMENT NUMBER		DOC TYPE	DOC PART	SHEET NUMBER
								934430030		PSD	000	7 OF 9		

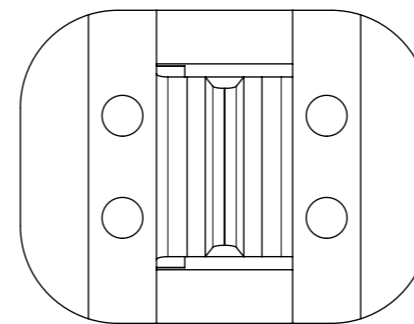
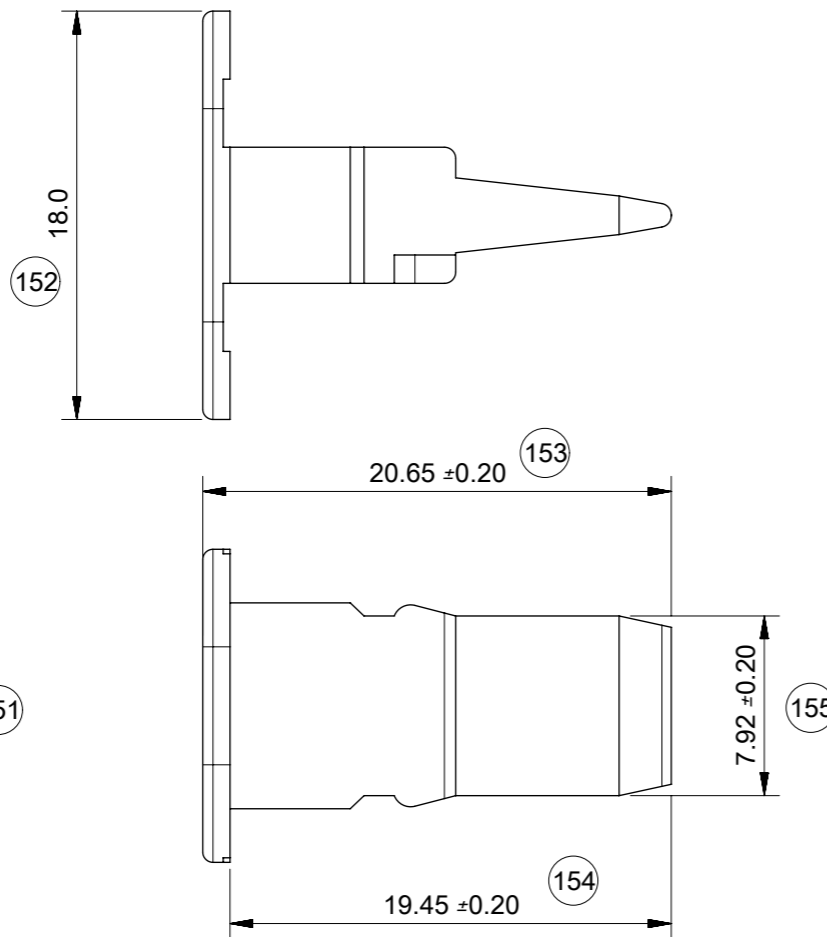
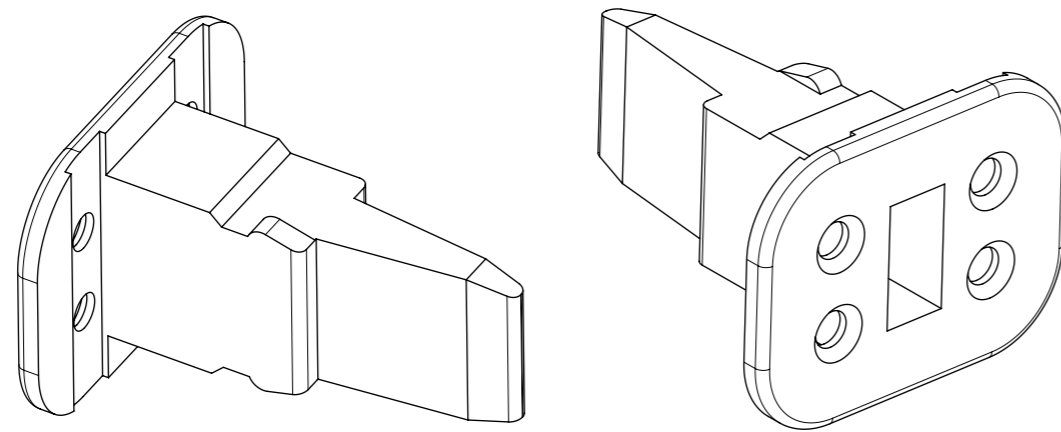

4CCT PLUG WEDGELOCK

SERIES NO. 93448 3 0 --

CIRCUIT SIZE 3 = 4CCT

COLOUR/KEYING
 03 = GREEN (NO KEY)
 12 = GREY A KEY
 21 = BLACK B KEY
 33 = GREEN C KEY
 47 = BROWN D KEY

NOTES
 1. MATERIAL
 HOUSING: NYLON 30%GF
 2. INSPECTION NUMBERS 151-200 RESERVED FOR SHEET 8
 3. PART NUMBER 934483003 SHOWN
 LAST INSPECTION NUMBER 155

QUALITY SYMBOLS ▽A = 0 ▽E = 0 ▽F = 0 ▼ = 0 ▽C = 0 ⊠ = 0 ■ = 0 ▽ = 0	THIS DRAWING CONTAINS INFORMATION THAT IS PROPRIETARY TO MOLEX ELECTRONIC TECHNOLOGIES, LLC AND SHOULD NOT BE USED WITHOUT WRITTEN PERMISSION										
	PROPOSED EC NO: 102420 DRWN: JFLETCHER CHK'D: NDOWDS APPR: JDWALLACE	GENERAL TOLERANCES (UNLESS SPECIFIED)		DIMENSION UNITS	SCALE						
		ANGULAR TOL ± 2.0 °		MM	3:1						
		4 PLACES ±	DRWN BY		DATE						
		3 PLACES ±	JFLETCHER		2015/11/02						
		2 PLACES ± 0.1	CHK'D BY		DATE						
	1 PLACE ± 0.2	NDOWDS		2015/11/10							
	0 PLACES ±	APPR BY		DATE							
	DRAFT WHERE APPLICABLE MUST REMAIN WITHIN DIMENSIONS	JDWALLACE		2015/11/16		PRODUCT CUSTOMER DRAWING					
		DRAWING SIZE	THIRD ANGLE PROJECTION		SERIES		MATERIAL NUMBER		CUSTOMER		
	A3			93443		SEE CHART		GENERAL MARKET			
				DOCUMENT NUMBER		DOC TYPE		DOC PART		SHEET NUMBER	
				934430030		PSD		000		8 OF 9	

934483012 (KEY A)
COLOUR GREY

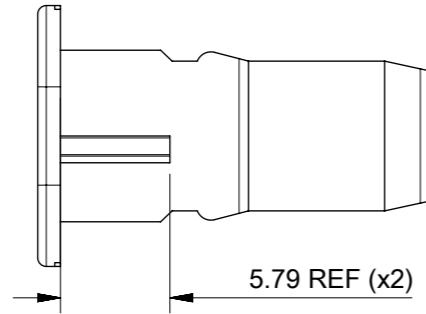
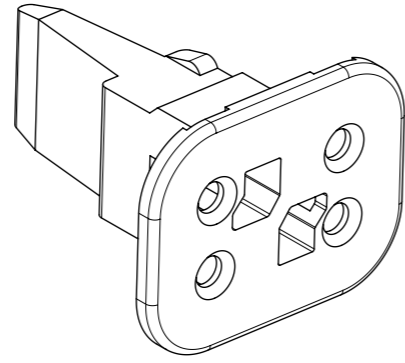
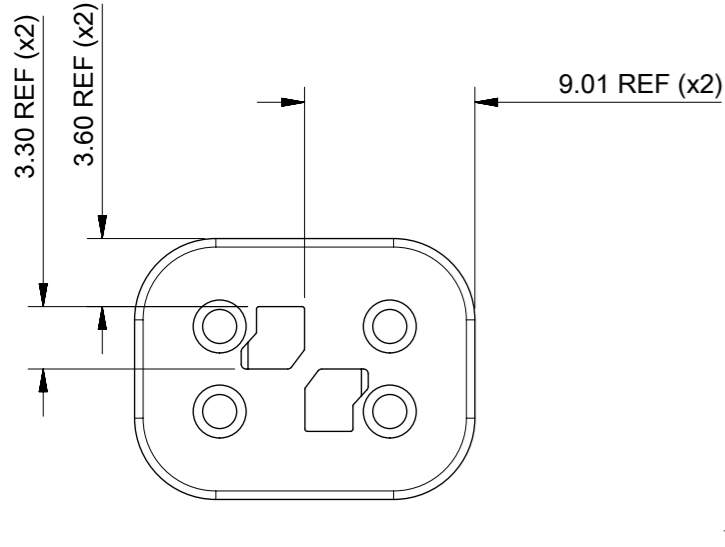

934483021 (KEY B)
COLOUR BLACK

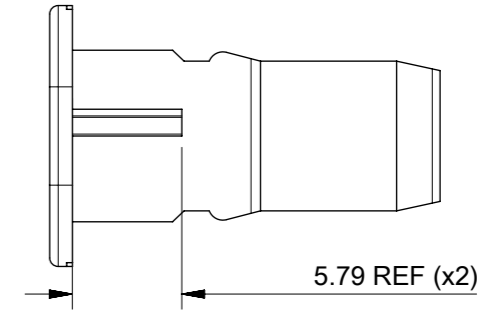
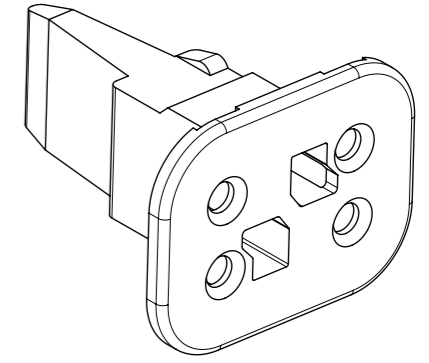
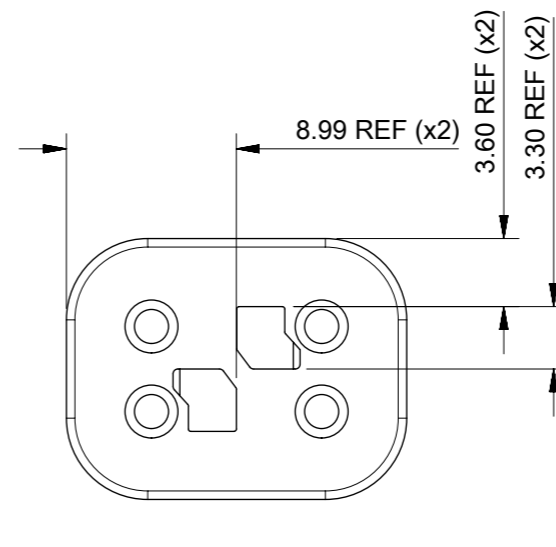

934483033 (KEY C)
COLOUR GREEN

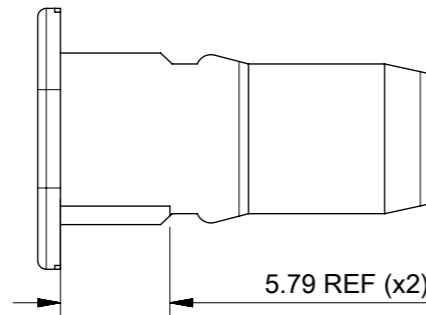
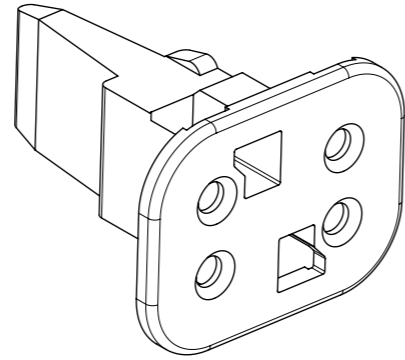
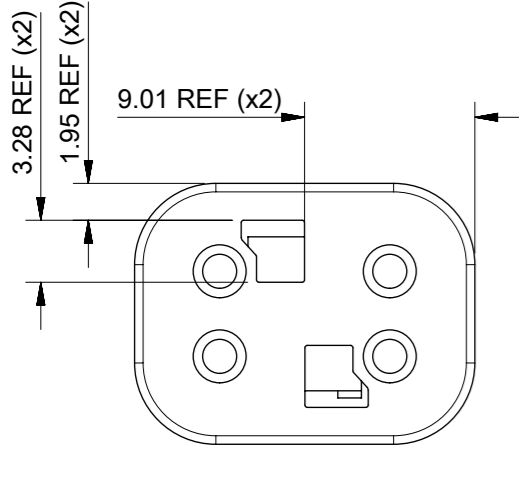

934483047 (KEY D)
COLOUR BROWN

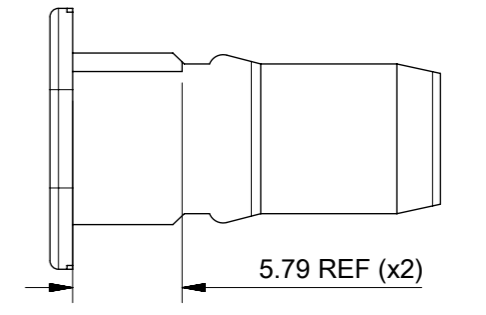
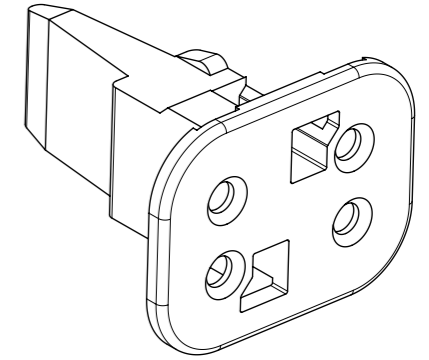
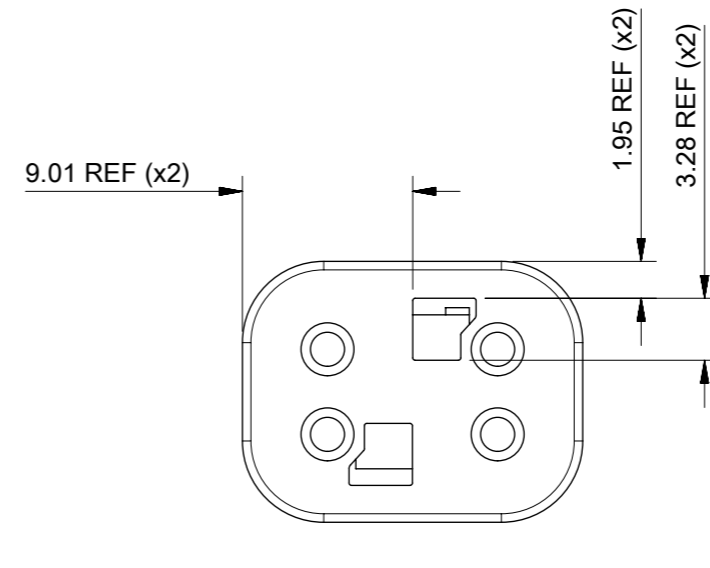

NOTES:
1. MATERIAL PA66 30%GF
2. SEE SHEET 4 FOR UNSPECIFIED NOTES & DIMENSIONS

THIS DRAWING CONTAINS INFORMATION THAT IS PROPRIETARY TO MOLEX ELECTRONIC TECHNOLOGIES, LLC AND SHOULD NOT BE USED WITHOUT WRITTEN PERMISSION																			
QUALITY SYMBOLS		PROPOSED		GENERAL TOLERANCES (UNLESS SPECIFIED)		DIMENSION UNITS		SCALE											
▽A	= 0	2016/01/07	2016/01/11	ANGULAR TOL ± 2.0 °		MM		2.5:1											
▽E	= 0	DRWN: JFLETCHER	CHK'D: NDOWDS	4 PLACES ±		DRWN BY		DATE		4CCT ML-XT CV CONNECTOR									
▽B	= 0	2016/01/11	2016/01/14	3 PLACES ±		JFLETCHER		2015/11/02											
▽	= 0	EC NO: 102420	APPR: JDWALLACE	2 PLACES ± 0.1		CHK'D BY		DATE		PRODUCT CUSTOMER DRAWING									
▽C	= 0			1 PLACE ± 0.2		NDOWDS		2015/11/10											
⊗	= 0			0 PLACES ±		APPR BY		DATE		<table border="1"> <tr> <td>SERIES</td><td>MATERIAL NUMBER</td><td>CUSTOMER</td> </tr> <tr> <td>93443</td><td>SEE CHART</td><td>GENERAL MARKET</td> </tr> </table>		SERIES	MATERIAL NUMBER	CUSTOMER	93443	SEE CHART	GENERAL MARKET		
SERIES	MATERIAL NUMBER	CUSTOMER																	
93443	SEE CHART	GENERAL MARKET																	
■	= 0			DRAFT WHERE APPLICABLE MUST REMAIN WITHIN DIMENSIONS		JDWALLACE		2015/11/16		<table border="1"> <tr> <td>DOCUMENT NUMBER</td><td>DOC TYPE</td><td>DOC PART</td><td>SHEET NUMBER</td> </tr> <tr> <td>934430030</td><td>PSD</td><td>000</td><td>9 OF 9</td> </tr> </table>		DOCUMENT NUMBER	DOC TYPE	DOC PART	SHEET NUMBER	934430030	PSD	000	9 OF 9
DOCUMENT NUMBER	DOC TYPE	DOC PART	SHEET NUMBER																
934430030	PSD	000	9 OF 9																
▽	= 0					DRAWING SIZE		THIRD ANGLE PROJECTION											
						A3													