

## 3A SIMPLE SWITCHER® Power Module with 4.5V-14.5V Input in QFN Package

Check for Samples: [LMZ31503](#)

### FEATURES

- Complete Integrated Power Solution Allows Small Footprint, Low-Profile Design
- 9mm x 15mm x 2.8mm package  
- Pin Compatible with LMZ31506
- Efficiencies Up To 95%
- Wide-Output Voltage Adjust  
0.8 V to 5.5 V, with 1% Reference Accuracy
- Optional Split Power Rail Allows Input Voltage Down to 1.6 V
- Adjustable Switching Frequency (330 kHz to 780 kHz)
- Synchronizes to an External Clock
- Adjustable Slow-Start
- Output Voltage Sequencing / Tracking
- Power Good Output
- Programmable Undervoltage Lockout (UVLO)
- Overcurrent Protection (Hiccup-Mode)
- Over Temperature Protection
- Pre-bias Output Start-up
- Operating Temperature Range:  $-40^{\circ}\text{C}$  to  $85^{\circ}\text{C}$
- Enhanced Thermal Performance:  $13^{\circ}\text{C/W}$
- Meets EN55022 Class B Emissions  
- Integrated Shielded Inductor

### APPLICATIONS

- Broadband & Communications Infrastructure
- Automated Test and Medical Equipment
- Compact PCI / PCI Express / PXI Express
- DSP and FPGA Point of Load Applications
- High Density Distributed Power Systems

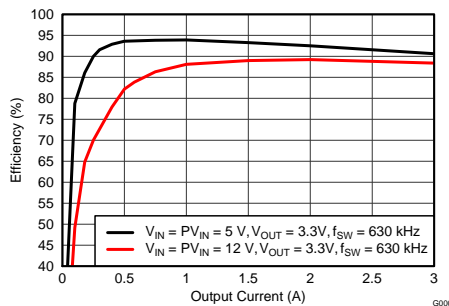

### DESCRIPTION

The LMZ31503 SIMPLE SWITCHER® power module is an easy-to-use integrated power solution that combines a 3-A DC/DC converter with power MOSFETs, a shielded inductor, and passives into a low profile, QFN package. This total power solution allows as few as 3 external components and eliminates the loop compensation and magnetics design process.

The 9x15x2.8 mm QFN package is easy to solder onto a printed circuit board and allows a compact point-of-load design with up to 95% efficiency and excellent power dissipation with a thermal impedance of  $13^{\circ}\text{C/W}$  junction to ambient. The device delivers the full 3-A rated output current at  $85^{\circ}\text{C}$  ambient temperature without airflow.

The LMZ31503 offers the flexibility and the feature-set of a discrete point-of-load design and is ideal for powering performance DSPs and FPGAs. Advanced packaging technology afford a robust and reliable power solution compatible with standard QFN mounting and testing techniques.

### SIMPLIFIED APPLICATION

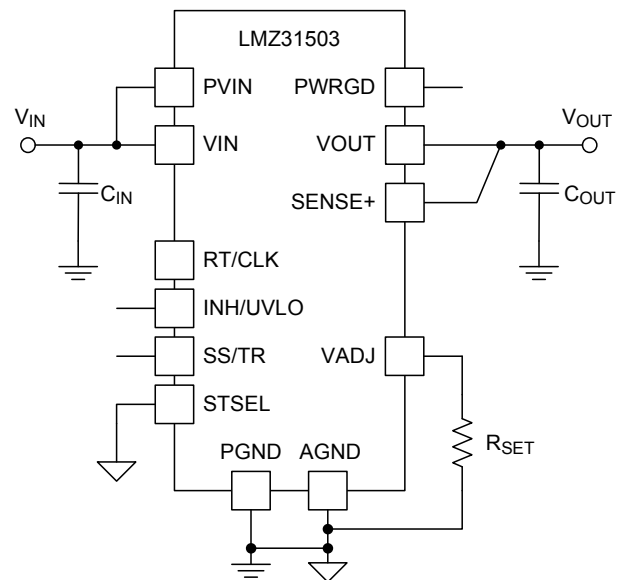

Please be aware that an important notice concerning availability, standard warranty, and use in critical applications of Texas Instruments semiconductor products and disclaimers thereto appears at the end of this data sheet.

SIMPLE SWITCHER is a registered trademark of Texas Instruments.



This integrated circuit can be damaged by ESD. Texas Instruments recommends that all integrated circuits be handled with appropriate precautions. Failure to observe proper handling and installation procedures can cause damage.

ESD damage can range from subtle performance degradation to complete device failure. Precision integrated circuits may be more susceptible to damage because very small parametric changes could cause the device not to meet its published specifications.

### ORDERING INFORMATION

For the most current package and ordering information, see the Package Option Addendum at the end of this datasheet, or see the TI website at [www.ti.com](http://www.ti.com).

### ABSOLUTE MAXIMUM RATINGS<sup>(1)</sup>

over operating temperature range (unless otherwise noted)		VALUE	UNIT
Input Voltage	VIN	–0.3 to 16	V
	PVIN	–0.3 to 16	V
	INH/UVLO	–0.3 to 6	V
	VADJ	–0.3 to 3	V
	PWRGD	–0.3 to 6	V
	SS/TR	–0.3 to 3	V
	STSEL	–0.3 to 3	V
	RT/CLK	–0.3 to 6	V
Output Voltage	PH	–1 to 20	V
	PH 10ns Transient	–3 to 20	V
V <sub>DIFF</sub> (GND to exposed thermal pad)		–0.2 to 0.2	V
Source Current	RT/CLK	±100	μA
	PH	Current Limit	A
Sink Current	PH	Current Limit	A
	PVIN	Current Limit	A
	PWRGD	–0.1 to 5	mA
Operating Junction Temperature		–40 to 125 <sup>(2)</sup>	°C
Storage Temperature		–65 to 150	°C
Mechanical Shock	Mil-STD-883D, Method 2002.3, 1 msec, 1/2 sine, mounted	1500	G
Mechanical Vibration	Mil-STD-883D, Method 2007.2, 20-2000Hz	20	

- (1) Stresses beyond those listed under absolute maximum ratings may cause permanent damage to the device. These are stress ratings only, and functional operation of the device at these or any other conditions beyond those indicated under recommended operating conditions is not implied. Exposure to absolute-maximum-rated conditions for extended periods may affect device reliability.
- (2) See the temperature derating curves in the Typical Characteristics section for thermal information.

**THERMAL INFORMATION**

THERMAL METRIC <sup>(1)</sup>		LMZ31503	UNIT
		RUQ47	
		47 PINS	
$\theta_{JA}$	Junction-to-ambient thermal resistance <sup>(2)</sup>	13	°C/W
$\psi_{JT}$	Junction-to-top characterization parameter <sup>(3)</sup>	2.5	
$\psi_{JB}$	Junction-to-board characterization parameter <sup>(4)</sup>	5	

- (1) For more information about traditional and new thermal metrics, see the IC Package Thermal Metrics application report, [SPRA953](#).
- (2) The junction-to-ambient thermal resistance,  $\theta_{JA}$ , applies to devices soldered directly to a 100 mm x 100 mm double-sided PCB with 1 oz. copper and natural convection cooling. Additional airflow reduces  $\theta_{JA}$ .
- (3) The junction-to-top characterization parameter,  $\psi_{JT}$ , estimates the junction temperature,  $T_J$ , of a device in a real system, using a procedure described in JESD51-2A (sections 6 and 7).  $T_J = \psi_{JT} * P_{dis} + T_T$ ; where  $P_{dis}$  is the power dissipated in the device and  $T_T$  is the temperature of the top of the device.
- (4) The junction-to-board characterization parameter,  $\psi_{JB}$ , estimates the junction temperature,  $T_J$ , of a device in a real system, using a procedure described in JESD51-2A (sections 6 and 7).  $T_J = \psi_{JB} * P_{dis} + T_B$ ; where  $P_{dis}$  is the power dissipated in the device and  $T_B$  is the temperature of the board 1mm from the device.

**PACKAGE SPECIFICATIONS**

LMZ31503		UNIT
Weight		1.26 grams
Flammability	Meets UL 94 V-O	
MTBF Calculated reliability	Per Bellcore TR-332, 50% stress, $T_A = 40^\circ\text{C}$ , ground benign	40.1 MHrs

## ELECTRICAL CHARACTERISTICS

Over -40°C to 85°C free-air temperature,  $P_{VIN} = V_{IN} = 12\text{ V}$ ,  $V_{OUT} = 1.8\text{ V}$ ,  $I_{OUT} = 3\text{ A}$ ,

$C_{IN1} = 2 \times 22\text{ }\mu\text{F}$  ceramic,  $C_{IN2} = 68\text{ }\mu\text{F}$  poly-tantalum,  $C_{OUT1} = 4 \times 47\text{ }\mu\text{F}$  ceramic (unless otherwise noted)

PARAMETER		TEST CONDITIONS	MIN	TYP	MAX	UNIT	
$I_{OUT}$	Output current	$T_A = 85^\circ\text{C}$ , natural convection	0		3	A	
$V_{IN}$	Input bias voltage range	Over $I_{OUT}$ range	4.5		14.5	V	
$P_{VIN}$	Input switching voltage range	Over $I_{OUT}$ range	1.6 <sup>(1)</sup>		14.5	V	
UVLO	VIN Undervoltage lockout	VIN = increasing		4.0	4.5	V	
		VIN = decreasing	3.5	3.85			
$V_{OUT(\text{adj})}$	Output voltage adjust range	Over $I_{OUT}$ range	0.8		5.5	V	
$V_{OUT}$	Set-point voltage tolerance	$T_A = 25^\circ\text{C}$ , $I_{OUT} = 0\text{ A}$			$\pm 1.0\%$ <sup>(2)</sup>		
	Temperature variation	$-40^\circ\text{C} \leq T_A \leq +85^\circ\text{C}$ , $I_{OUT} = 0\text{ A}$		$\pm 0.3\%$			
	Line regulation	Over $P_{VIN}$ range, $T_A = 25^\circ\text{C}$ , $I_{OUT} = 0\text{ A}$		$\pm 0.1\%$			
	Load regulation	Over $I_{OUT}$ range, $T_A = 25^\circ\text{C}$		$\pm 0.1\%$			
	Total output voltage variation	Includes set-point, line, load, and temperature variation				$\pm 1.5\%$ <sup>(2)</sup>	
$\eta$	Efficiency	$P_{VIN} = V_{IN} = 12\text{ V}$ $I_O = 1.5\text{ A}$	$V_{OUT} = 5\text{ V}$ , $f_{SW} = 780\text{ kHz}$		91.5 %		
			$V_{OUT} = 3.3\text{ V}$ , $f_{SW} = 630\text{ kHz}$		89.0 %		
			$V_{OUT} = 2.5\text{ V}$ , $f_{SW} = 480\text{ kHz}$		86.9 %		
			$V_{OUT} = 1.8\text{ V}$ , $f_{SW} = 480\text{ kHz}$		85.2 %		
			$V_{OUT} = 1.2\text{ V}$ , $f_{SW} = 480\text{ kHz}$		82.1 %		
			$V_{OUT} = 0.8\text{ V}$ , $f_{SW} = 330\text{ kHz}$		78.7 %		
		$P_{VIN} = V_{IN} = 5\text{ V}$ $I_O = 1.5\text{ A}$	$V_{OUT} = 3.3\text{ V}$ , $f_{SW} = 630\text{ kHz}$		93.3 %		
			$V_{OUT} = 2.5\text{ V}$ , $f_{SW} = 480\text{ kHz}$		91.4 %		
			$V_{OUT} = 1.8\text{ V}$ , $f_{SW} = 480\text{ kHz}$		88.8 %		
			$V_{OUT} = 1.2\text{ V}$ , $f_{SW} = 480\text{ kHz}$		85.2 %		
		$V_{OUT} = 0.8\text{ V}$ , $f_{SW} = 330\text{ kHz}$		81.8 %			
	Output voltage ripple	20 MHz bandwidth		35		mV <sub>PP</sub>	
$I_{LIM}$	Overcurrent threshold			5.8		A	
	Transient response	1.0 A/ $\mu\text{s}$ load step from 50 to 100% $I_{OUT(\text{max})}$	Recovery time		190	$\mu\text{s}$	
			$V_{OUT}$ over/undershoot		35	mV	
$V_{INH-H}$	Inhibit Control	Inhibit High Voltage	1.30		Open <sup>(3)</sup>	V	
$V_{INH-L}$		Inhibit Low Voltage	-0.3		1.05		
	INH Input current	$INH < 1.1\text{ V}$		-1.15		$\mu\text{A}$	
	INH Hysteresis current	$INH > 1.26\text{ V}$		-3.4		$\mu\text{A}$	
$I_{I(\text{stby})}$	Input standby current	INH pin to AGND		2	4	$\mu\text{A}$	
Power Good	PWRGD Thresholds	$V_{OUT}$ rising	Good		94%		
			Fault		109%		
		$V_{OUT}$ falling	Fault		91%		
			Good		106%		
	PWRGD Low Voltage	$I(\text{PWRGD}) = 2\text{ mA}$			0.3	V	
$f_{SW}$	Switching frequency	Over $V_{IN}$ and $I_{OUT}$ ranges, RT/CLK pin OPEN	270	330	390	kHz	
$f_{CLK}$	Synchronization frequency	CLK Control		330	780	kHz	
$V_{CLK-H}$	CLK High-Level Threshold			2.0	5.5	V	
$V_{CLK-L}$	CLK Low-Level Threshold				0.8	V	
$D_{CLK}$	CLK Duty cycle			20%	80%		
	Thermal Shutdown		Thermal shutdown	160	175		$^\circ\text{C}$
		Thermal shutdown hysteresis		10		$^\circ\text{C}$	

(1) The minimum  $P_{VIN}$  voltage is 1.6V or ( $V_{OUT} + 0.7\text{ V}$ ), whichever is greater.  $V_{IN}$  must be greater than 4.5V.

(2) The stated limit of the set-point voltage tolerance includes the tolerance of both the internal voltage reference and the internal adjustment resistor. The overall output voltage tolerance will be affected by the tolerance of the external  $R_{SET}$  resistor.

(3) This control pin has an internal pullup. If this pin is left open circuit, the device operates when input power is applied. A small low-leakage (<300 nA) MOSFET is recommended for control. See the application section for further guidance.

**ELECTRICAL CHARACTERISTICS (continued)**

Over -40°C to 85°C free-air temperature,  $P_{VIN} = V_{IN} = 12\text{ V}$ ,  $V_{OUT} = 1.8\text{ V}$ ,  $I_{OUT} = 3\text{ A}$ ,  
 $C_{IN1} = 2 \times 22\text{ }\mu\text{F}$  ceramic,  $C_{IN2} = 68\text{ }\mu\text{F}$  poly-tantalum,  $C_{OUT1} = 4 \times 47\text{ }\mu\text{F}$  ceramic (unless otherwise noted)

PARAMETER	TEST CONDITIONS	MIN	TYP	MAX	UNIT
$C_{IN}$ External input capacitance	Ceramic	22 <sup>(4)</sup>			$\mu\text{F}$
	Non-ceramic	68 <sup>(4)</sup>			
$C_{OUT}$ External output capacitance	Ceramic	200 <sup>(5)</sup>		1500	$\mu\text{F}$
	Non-ceramic			5000	
	Equivalent series resistance (ESR)				35

- (4) A minimum of 68 $\mu\text{F}$  of polymer tantalum and/or ceramic external capacitance is required across the input ( $V_{IN}$  and  $\text{PGND}$  connected) for proper operation. Locate the capacitor close to the device. See Table 5 for more details. When operating with split  $V_{IN}$  and  $P_{VIN}$  rails, place 4.7 $\mu\text{F}$  of ceramic capacitance directly at the  $V_{IN}$  pin to  $\text{PGND}$ .
- (5) The amount of required output capacitance varies depending on the output voltage (see Table 3). The amount of required capacitance must include ceramic capacitance. Locate the capacitance close to the device. Adding additional capacitance close to the load improves the response of the regulator to load transients. See Table 3 and Table 5 more details.

**DEVICE INFORMATION**

**FUNCTIONAL BLOCK DIAGRAM**

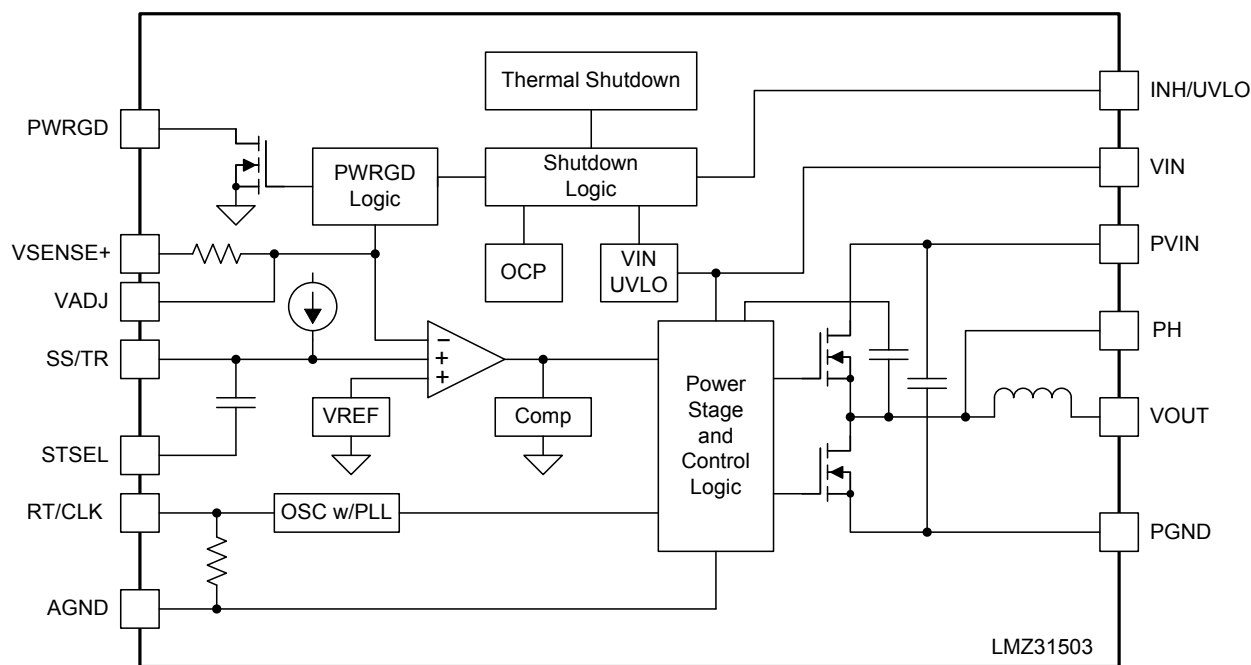

### PIN DESCRIPTIONS

TERMINAL		DESCRIPTION
NAME	NO.	
AGND	1	Zero VDC reference for the analog control circuitry. Connect AGND to PGND at a single point. Connect near the output capacitors. See for a recommended layout.
	2	
	34	
	45	
INH/UVLO	8	Inhibit and UVLO adjust pin. Use an open drain or open collector output logic to control the INH function. A resistor divider between this pin, AGND and VIN adjusts the UVLO voltage. Tie both pins together when using this control.
	9	
DNC	3	Do Not Connect. Do not connect these pins to AGND, to another DNC pin, or to any other voltage. These pins are connected to internal circuitry. Each pin must be soldered to an isolated pad.
	4	
	5	
	15	
	16	
	18	
	19	
	20	
	22	
	23	
	30	
	31	
32		
PGND	36	Common ground connection for the PVIN, VIN, and VOUT power connections. See for a recommended layout.
	37	
	38	
PH	10	Phase switch node. These pins should be connected to a small copper island under the device for thermal relief. Do not place any external component on this pin or tie it to a pin of another function.
	11	
	12	
	13	
	14	
	17	
46		
PWRGD	33	Power good fault pin. Asserts low if the output voltage is low. A pull-up resistor is required.
PVIN	39	Input switching voltage. This pin supplies voltage to the power switches of the converter. See for a recommended layout.
	40	
	41	
RT/CLK	35	This pin automatically selects between RT mode and CLK mode. An external timing resistor adjusts the switching frequency of the device. In CLK mode, the device synchronizes to an external clock.
SENSE+	44	Remote sense connection. Connect this pin to VOUT at the load for improved regulation. This pin must be connected to VOUT at the load, or at the module pins.
SS/TR	6	Slow-start and tracking pin. Connecting an external capacitor to this pin adjusts the output voltage rise time. A voltage applied to this pin allows for tracking and sequencing control.
STSEL	7	Slow-start or track feature select. Connect this pin to AGND to enable the internal SS capacitor with a SS interval of approximately 1.1 ms. Leave this pin open to enable the TR feature.
VADJ	43	Connecting a resistor between this pin and AGND sets the output voltage.
VIN	42	Input bias voltage pin. Supplies the control circuitry of the power converter. See for a recommended layout.

**PIN DESCRIPTIONS (continued)**

TERMINAL		DESCRIPTION
NAME	NO.	
VOUT	21	Output voltage. Connect output capacitors between these pins and PGND.
	24	
	25	
	26	
	27	
	28	
	29	
	47	

**RUQ PACKAGE  
47 PINS  
(TOP VIEW)**

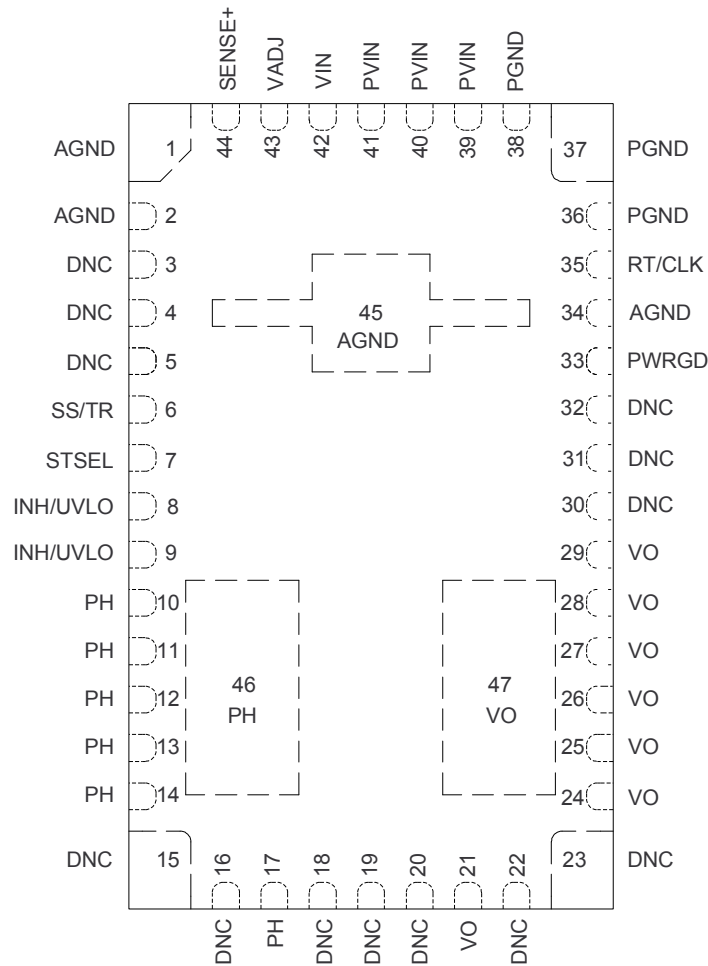

TYPICAL CHARACTERISTICS (P<sub>VIN</sub> = V<sub>IN</sub> = 12 V) (1) (2)

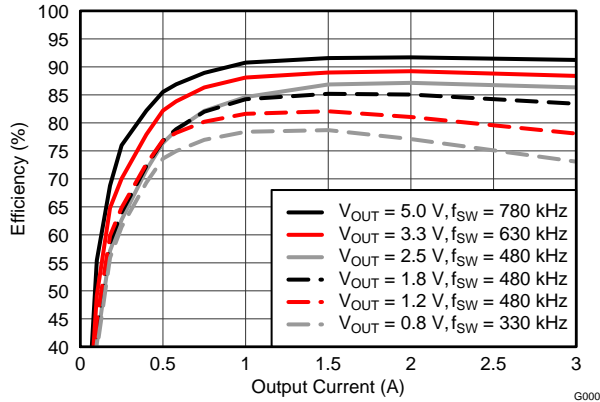

Figure 1. Efficiency vs. Output Current

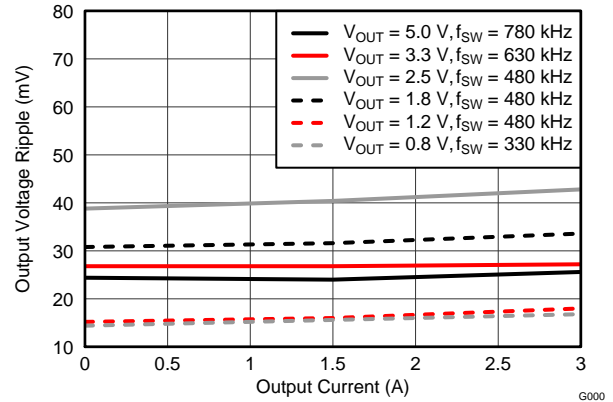

Figure 2. Voltage Ripple vs. Output Current

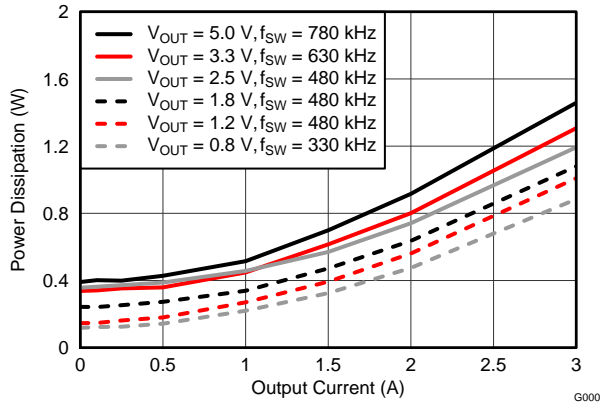

Figure 3. Power Dissipation vs. Output Current

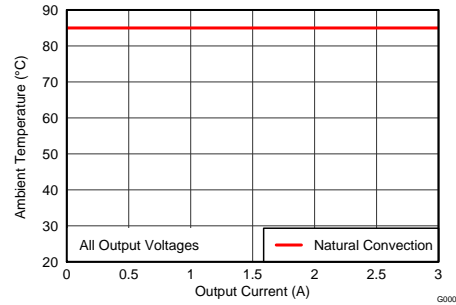

Figure 4. Safe Operating Area

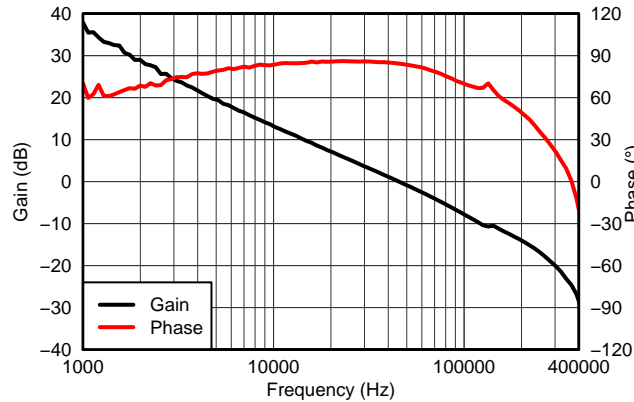

Figure 5. V<sub>OUT</sub>= 1.8 V, I<sub>OUT</sub>= 3 A, C<sub>OUT1</sub>= 100 μF ceramic, C<sub>OUT2</sub>= 100 μF ceramic, f<sub>SW</sub>= 480 kHz

- (1) The electrical characteristic data has been developed from actual products tested at 25°C. This data is considered typical for the converter. Applies to Figure 1, Figure 2, and Figure 3.
- (2) The temperature derating curves represent the conditions at which internal components are at or below the manufacturer's maximum operating temperatures. Derating limits apply to devices soldered directly to a 100 mm × 100 mm double-sided PCB with 1 oz. copper. Applies to Figure 4.

TYPICAL CHARACTERISTICS (P<sub>VIN</sub> = V<sub>IN</sub> = 5 V) (1) (2)

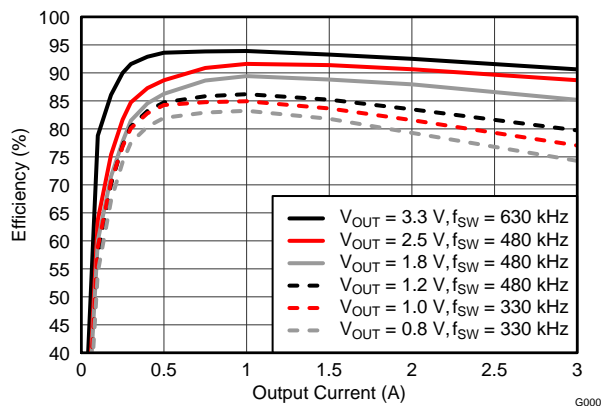

Figure 6. Efficiency vs. Output Current

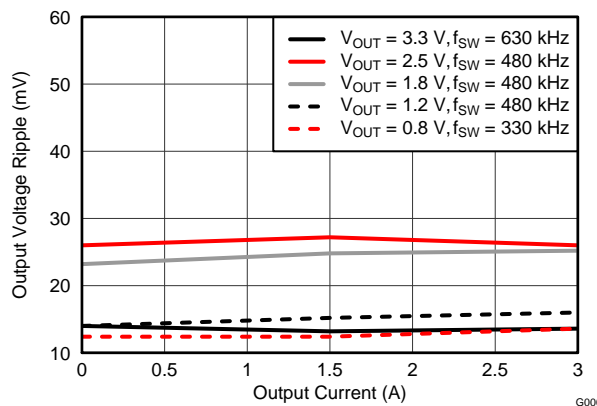

Figure 7. Voltage Ripple vs. Output Current

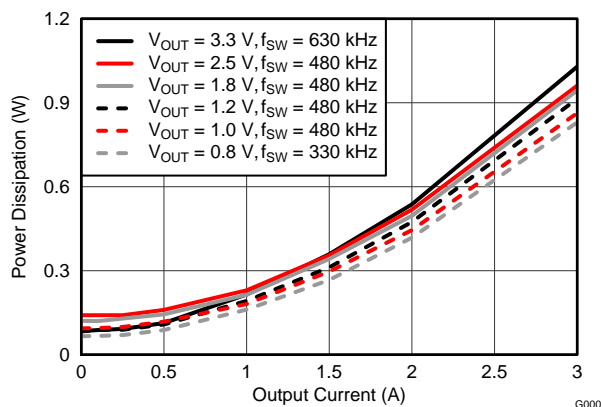

Figure 8. Power Dissipation vs. Output Current

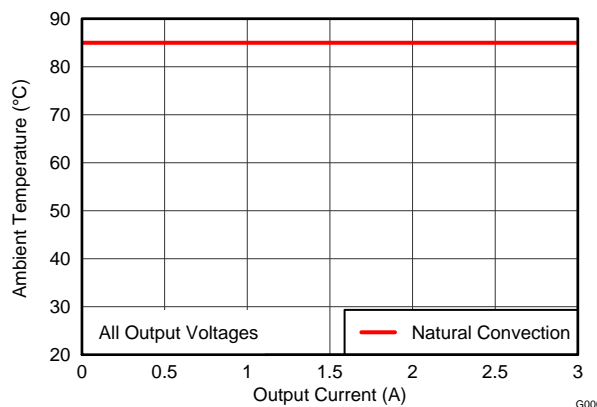

Figure 9. Safe Operating Area

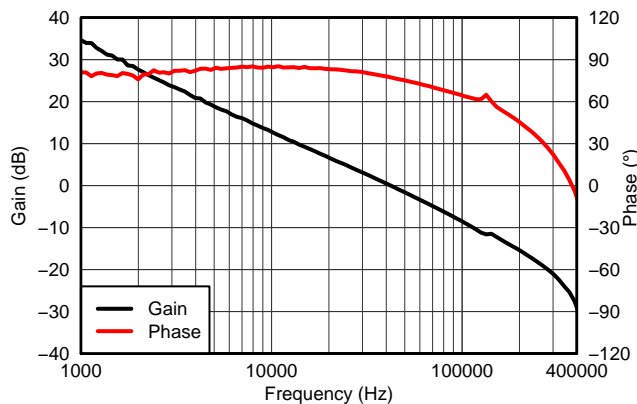

Figure 10. V<sub>OUT</sub>=1.8 V, I<sub>OUT</sub>=3 A, C<sub>OUT1</sub>= 100 μF ceramic, C<sub>OUT2</sub>= 100 μF ceramic, f<sub>SW</sub>= 480 kHz

- (1) The electrical characteristic data has been developed from actual products tested at 25°C. This data is considered typical for the converter. Applies to Figure 6, Figure 7, and Figure 8.
- (2) The temperature derating curves represent the conditions at which internal components are at or below the manufacturer's maximum operating temperatures. Derating limits apply to devices soldered directly to a 100 mm × 100 mm double-sided PCB with 1 oz. copper. Applies to Figure 9.

TYPICAL CHARACTERISTICS (P<sub>VIN</sub> = 12 V, V<sub>IN</sub> = 5 V) <sup>(1)</sup> <sup>(2)</sup>

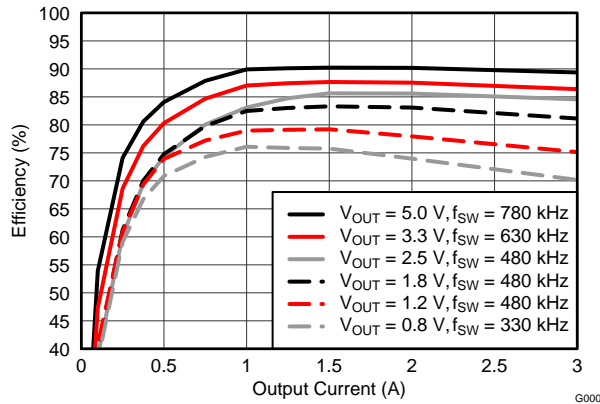

Figure 11. Efficiency vs. Output Current

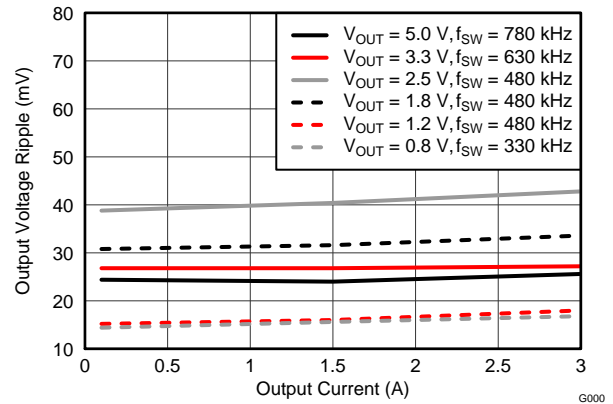

Figure 12. Voltage Ripple vs. Output Current

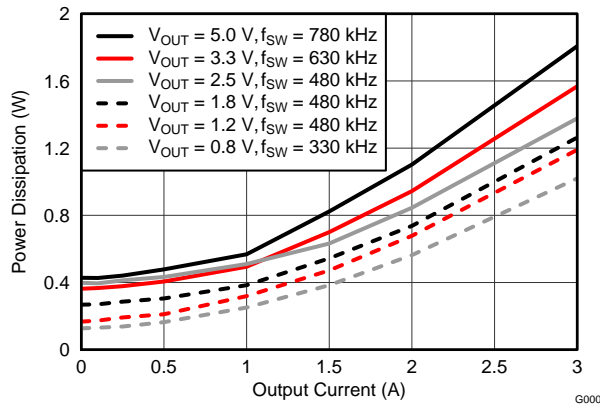

Figure 13. Power Dissipation vs. Output Current

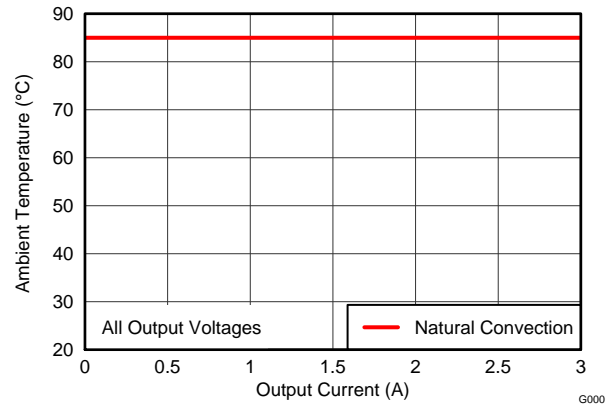

Figure 14. Safe Operating Area

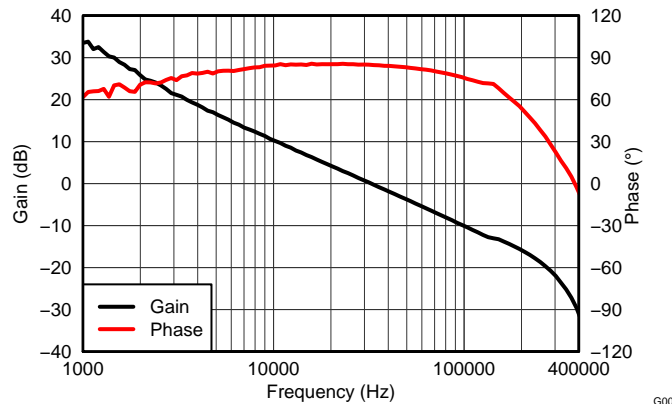

Figure 15. V<sub>OUT</sub>=2.5 V, I<sub>OUT</sub>=3 A, C<sub>OUT1</sub>= 100 μF ceramic, C<sub>OUT2</sub>= 100 μF ceramic, f<sub>SW</sub>= 480 kHz

- (1) The electrical characteristic data has been developed from actual products tested at 25°C. This data is considered typical for the converter. Applies to [Figure 11](#), [Figure 12](#), and [Figure 13](#).
- (2) The temperature derating curves represent the conditions at which internal components are at or below the manufacturer's maximum operating temperatures. Derating limits apply to devices soldered directly to a 100 mm × 100 mm double-sided PCB with 1 oz. copper. Applies to [Figure 14](#).

## APPLICATION INFORMATION

### ADJUSTING THE OUTPUT VOLTAGE

The VADJ control sets the output voltage of the LMZ31503. The output voltage adjustment range is from 0.8V to 5.5V. The adjustment method requires the addition of R<sub>SET</sub>, which sets the output voltage, the connection of SENSE+ to VOUT, and in some cases R<sub>RT</sub> which sets the switching frequency. The R<sub>SET</sub> resistor must be connected directly between the VADJ (pin 43) and AGND (pin 45). The SENSE+ pin (pin 44) must be connected to VOUT either at the load for improved regulation or at VOUT of the module. The R<sub>RT</sub> resistor must be connected directly between the RT/CLK (pin 35) and AGND (pin 34).

Table 1 gives the standard external R<sub>SET</sub> resistor for a number of common bus voltages, along with the required R<sub>RT</sub> resistor for that output voltage. For other output voltages, the value of the required resistor can either be calculated using Equation 1, or selected from the values given in Table 2.

**Table 1. Standard R<sub>SET</sub> Resistor Values for Common Output Voltages**

RESISTORS	OUTPUT VOLTAGE V <sub>OUT</sub> (V)							
	0.8	1.0	1.2	1.5	1.8	2.5	3.3	5.0
R <sub>SET</sub> (kΩ)	open	5.76	2.87	1.62	1.13	0.665	0.453	0.267
R <sub>RT</sub> (kΩ)	open	open	324	324	324	324	158	105

$$R_{SET} = \frac{1.43}{\left(\left(\frac{V_{OUT}}{0.8}\right) - 1\right)} \text{ (k}\Omega\text{)} \quad (1)$$

**Table 2. Standard R<sub>SET</sub> Resistor Values**

V <sub>OUT</sub> (V)	R <sub>SET</sub> (kΩ)	R <sub>RT</sub> (kΩ)	f <sub>sw</sub> (kHz)	V <sub>OUT</sub> (V)	R <sub>SET</sub> (kΩ)	R <sub>RT</sub> (kΩ)	f <sub>sw</sub> (kHz)
0.8	open	open	330	3.2	0.475	191	580
0.9	11.3	open	330	3.3	0.453	158	630
1.0	5.76	open	330	3.4	0.442	158	630
1.1	3.83	open	330	3.5	0.422	158	630
1.2	2.87	324	480	3.6	0.402	158	630
1.3	2.26	324	480	3.7	0.392	158	630
1.4	1.91	324	480	3.8	0.374	137	680
1.5	1.62	324	480	3.9	0.365	137	680
1.6	1.43	324	480	4.0	0.357	137	680
1.7	1.27	324	480	4.1	0.348	137	680
1.8	1.13	324	480	4.2	0.332	118	730
1.9	1.02	324	480	4.3	0.324	118	730
2.0	0.953	324	480	4.4	0.316	118	730
2.1	0.866	324	480	4.5	0.309	118	730
2.2	0.806	324	480	4.6	0.301	118	730
2.3	0.750	324	480	4.7	0.294	118	730
2.4	0.715	324	480	4.8	0.287	105	780
2.5	0.665	324	480	4.9	0.280	105	780
2.6	0.634	237	530	5.0	0.267	105	780
2.7	0.604	237	530	5.1	0.267	105	780
2.8	0.562	237	530	5.2	0.261	105	780
2.9	0.536	237	530	5.3	0.255	105	780
3.0	0.511	191	580	5.4	0.249	105	780
3.1	0.499	191	580	5.5	0.243	105	780

## CAPACITOR RECOMMENDATIONS FOR THE LMZ31503 POWER SUPPLY

### Capacitor Technologies

#### *Electrolytic, Polymer-Electrolytic Capacitors*

When using electrolytic capacitors, high-quality, computer-grade electrolytic capacitors are recommended. Polymer-electrolytic type capacitors are recommended for applications where the ambient operating temperature is less than 0°C. The Sanyo OS-CON capacitor series is suggested due to the lower ESR, higher rated surge, power dissipation, ripple current capability, and small package size. Aluminum electrolytic capacitors provide adequate decoupling over the frequency range of 2 kHz to 150 kHz, and are suitable when ambient temperatures are above 0°C.

#### *Ceramic Capacitors*

The performance of aluminum electrolytic capacitors is less effective than ceramic capacitors above 150 kHz. Multilayer ceramic capacitors have a low ESR and a resonant frequency higher than the bandwidth of the regulator. They can be used to reduce the reflected ripple current at the input as well as improve the transient response of the output.

#### *Tantalum, Polymer-Tantalum Capacitors*

Polymer-tantalum type capacitors are recommended for applications where the ambient operating temperature is less than 0°C. The Sanyo POSCAP series and Kemet T530 capacitor series are recommended rather than many other tantalum types due to their lower ESR, higher rated surge, power dissipation, ripple current capability, and small package size. Tantalum capacitors that have no stated ESR or surge current rating are not recommended for power applications.

### Input Capacitor

The LMZ31503 requires a minimum input capacitance of 68  $\mu\text{F}$  of ceramic and/or polymer-tantalum capacitors. The ripple current rating of the capacitor must be at least 450 mArms. [Table 5](#) includes a preferred list of capacitors by vendor.

### Output Capacitor

The required output capacitance is determined by the output voltage of the LMZ31503. See [Table 3](#) for the amount of required capacitance. The required output capacitance must be comprised of all ceramic capacitors. When adding additional non-ceramic bulk capacitors, low-ESR devices like the ones recommended in [Table 5](#) are required. The required capacitance above the minimum is determined by actual transient deviation requirements. See [Table 4](#) for typical transient response values for several output voltage, input voltage and capacitance combinations. [Table 5](#) includes a preferred list of capacitors by vendor.

**Table 3. Required Output Capacitance**

V <sub>OUT</sub> RANGE (V)		MINIMUM REQUIRED C <sub>OUT</sub> ( $\mu\text{F}$ )
MIN	MAX	
0.8	< 1.2	6x 47 $\mu\text{F}$ ceramic
1.2	< 3.0	4x 47 $\mu\text{F}$ ceramic
3.0	< 4.0	2x 47 $\mu\text{F}$ ceramic
4.0	5.5	47 $\mu\text{F}$ ceramic

**Table 4. Output Voltage Transient Response**

<b>C<sub>IN1</sub> = 22 μF CERAMIC, C<sub>IN2</sub> = 68 μF POSCAP, LOAD STEP = 1.5 A, 1 A/μs</b>						
<b>V<sub>OUT</sub> (V)</b>	<b>PV<sub>IN</sub> (V)</b>	<b>C<sub>OUT1</sub> Ceramic</b>	<b>C<sub>OUT2</sub> BULK</b>	<b>VOLTAGE DEVIATION (mV)</b>	<b>PEAK-PEAK (mV)</b>	<b>RECOVERY TIME (μs)</b>
0.8	5	6x 47 μF	None	25	55	170
		6x 47 μF	330 μF	15	30	160
	12	6x 47 μF	None	20	35	180
		6x 47 μF	330 μF	15	30	170
1.0	5	6x 47 μF	None	20	40	170
		6x 47 μF	330 μF	15	30	170
	12	6x 47 μF	None	20	45	180
		6x 47 μF	330 μF	15	30	170
1.2	5	4x 47 μF	None	30	55	170
		4x 47 μF	220 μF	25	45	170
	12	4x 47 μF	None	30	55	180
		4x 47 μF	220 μF	25	50	170
1.8	5	4x 47 μF	None	35	65	180
		4x 47 μF	220 μF	30	55	180
	12	4x 47 μF	None	35	65	190
		4x 47 μF	220 μF	30	55	180
3.3	5	2x 47 μF	None	65	130	190
		2x 47 μF	100 μF	55	110	190
	12	2x 47 μF	None	65	130	200
		2x 47 μF	100 μF	60	120	200
5.0	12	1x 47 μF	None	100	200	210
		1x 47 μF	100 μF	85	170	210

**Table 5. Recommended Input/Output Capacitors<sup>(1)</sup>**

<b>VENDOR</b>	<b>SERIES</b>	<b>PART NUMBER</b>	<b>CAPACITOR CHARACTERISTICS</b>		
			<b>WORKING VOLTAGE (V)</b>	<b>CAPACITANCE (μF)</b>	<b>ESR<sup>(2)</sup> (mΩ)</b>
Murata	X5R	GRM32ER61E226K	16	22	2
TDK	X5R	C3225X5R0J476K	6.3	47	2
Murata	X5R	GRM32ER60J476M	6.3	47	2
Sanyo	POSCAP	16TQC68M	16	68	50
Kemet	T520	T520V107M010ASE025	10	100	25
Sanyo	POSCAP	6TPE100MI	6.3	100	25
Sanyo	POSCAP	2R5TPE220M7	2.5	220	7
Kemet	T530	T530D227M006ATE006	6.3	220	6
Kemet	T530	T530D337M006ATE010	6.3	330	10
Sanyo	POSCAP	2TPF330M6	2.0	330	6
Sanyo	POSCAP	6TPE330MFL	6.3	330	15

**(1) Capacitor Supplier Verification**

Please verify availability of capacitors identified in this table.

**RoHS, Lead-free and Material Details**

Please consult capacitor suppliers regarding material composition, RoHS status, lead-free status, and manufacturing process requirements.

**(2) Maximum ESR @ 100kHz, 25°C.**

Transient Response

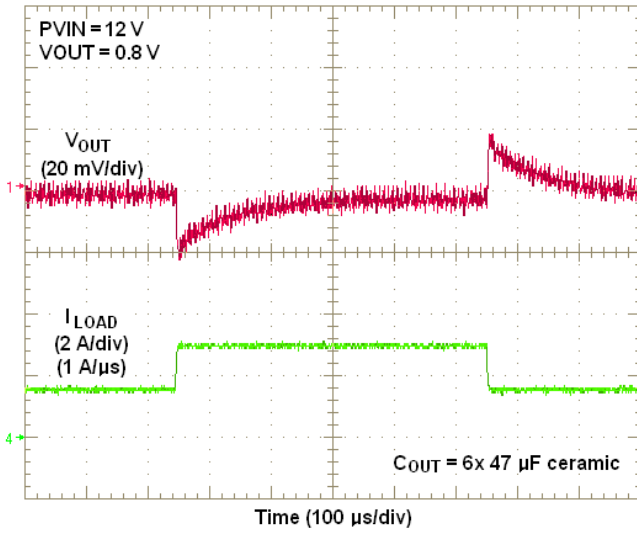

Figure 16.  $P_{VIN} = 12V$ ,  $V_{OUT} = 0.8V$ , 1.5A Load Step

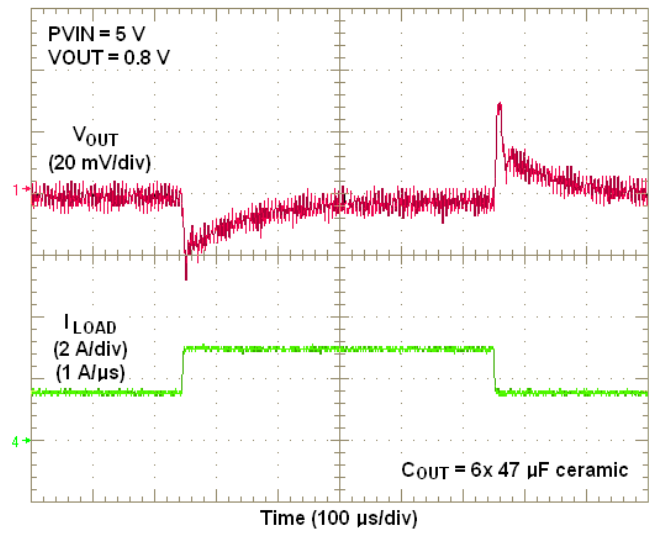

Figure 17.  $P_{VIN} = 5V$ ,  $V_{OUT} = 0.8V$ , 1.5A Load Step

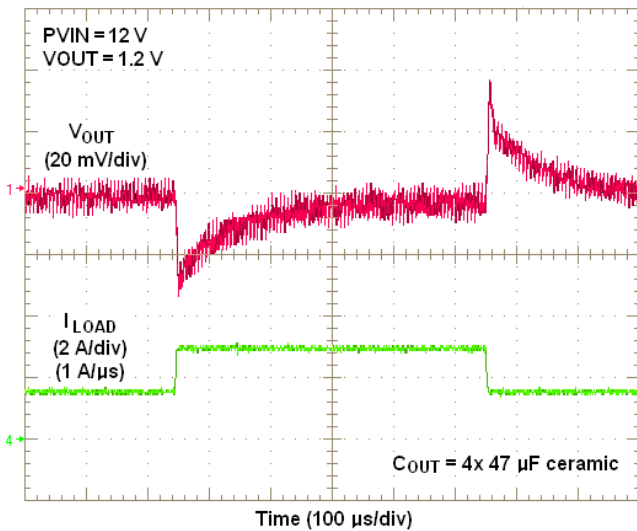

Figure 18.  $P_{VIN} = 12V$ ,  $V_{OUT} = 1.2V$ , 1.5A Load Step

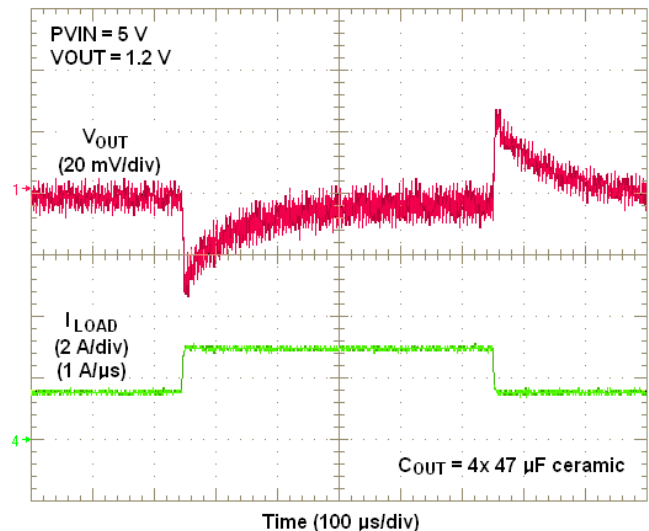

Figure 19.  $P_{VIN} = 5V$ ,  $V_{OUT} = 1.2V$ , 1.5A Load Step

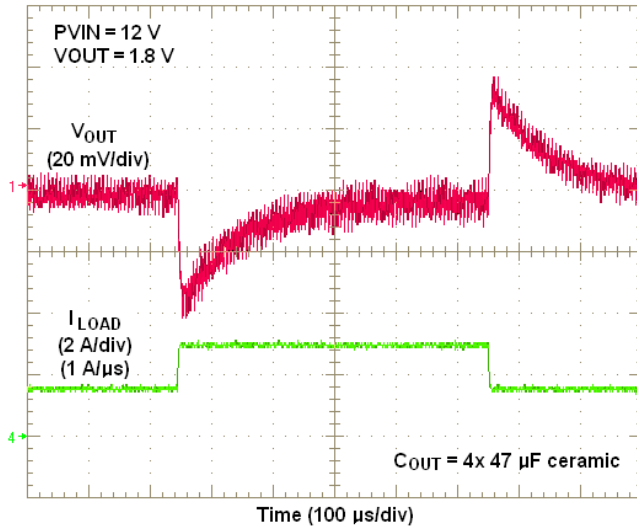

Figure 20. PVIN = 12V, VOUT = 1.8V, 1.5A Load Step

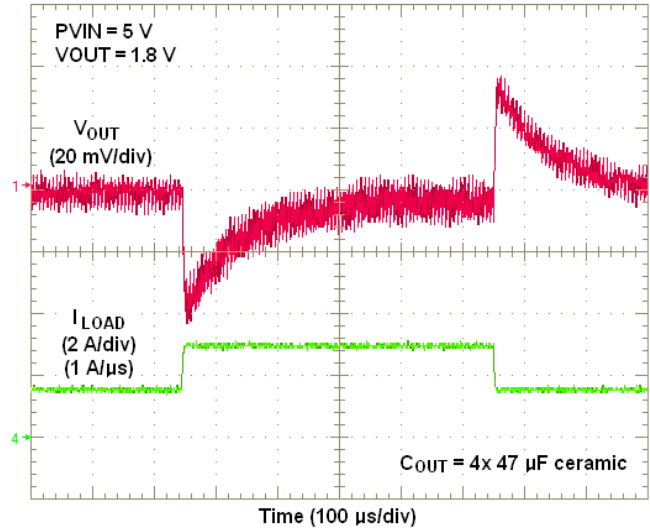

Figure 21. PVIN = 5V, VOUT = 1.8V, 1.5A Load Step

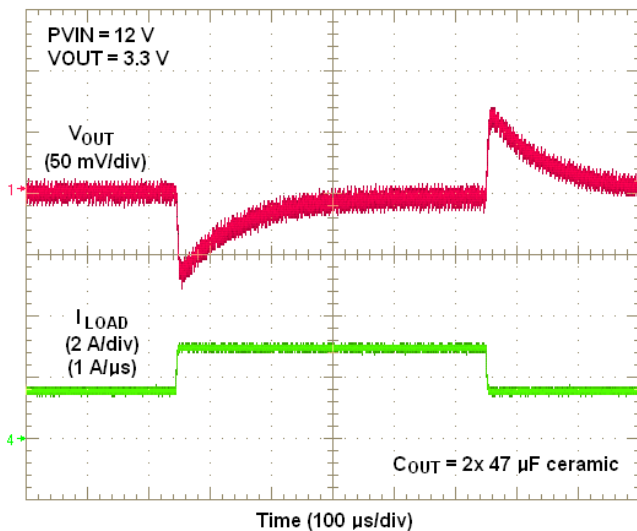

Figure 22. PVIN = 12V, VOUT = 3.3V, 1.5A Load Step

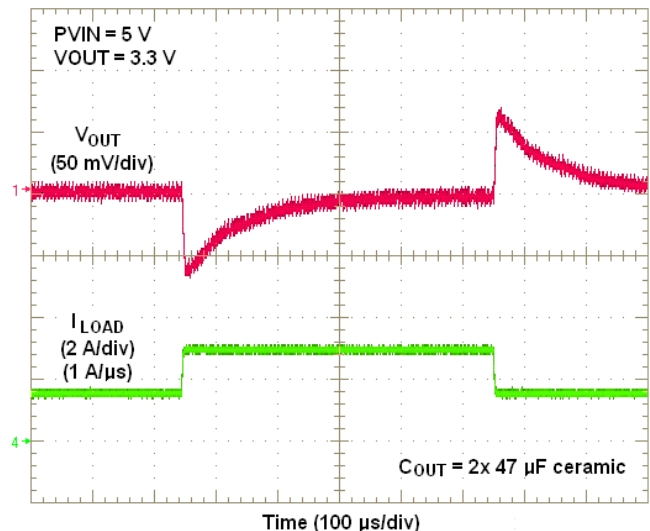
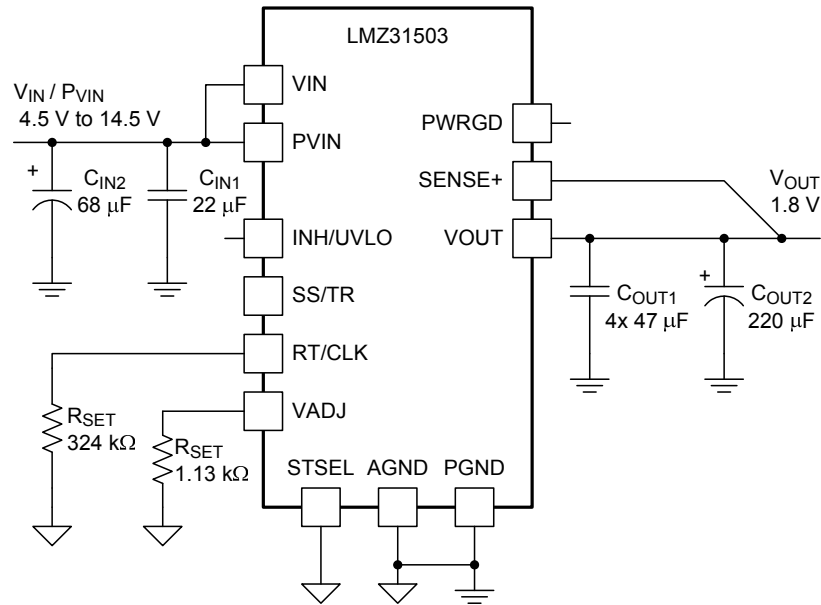
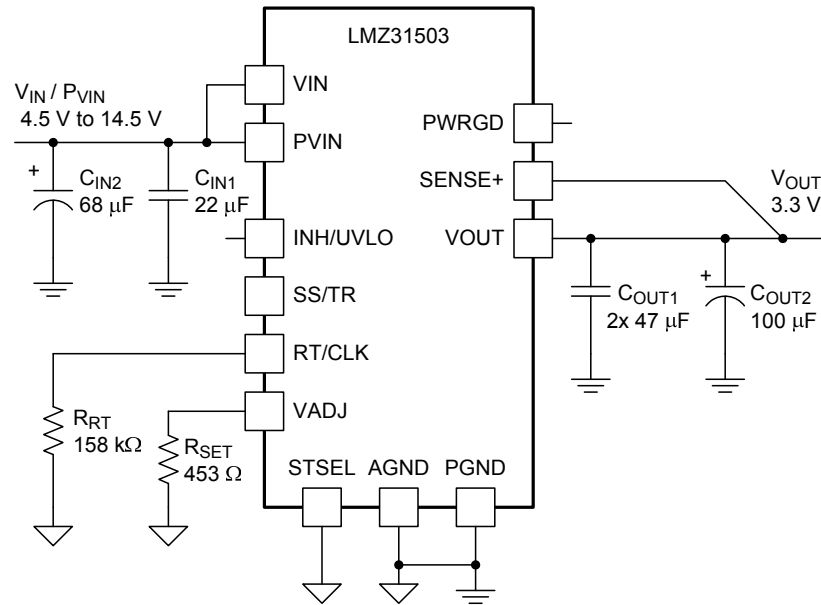

Figure 23. PVIN = 5V, VOUT = 3.3V, 1.5A Load Step

Application Schematics



**Figure 24. Typical Schematic**  
**PVIN = VIN = 4.5 V to 14.5 V, VOUT = 1.8 V**



**Figure 25. Typical Schematic**  
**PVIN = VIN = 4.5 V to 14.5 V, VOUT = 3.3 V**

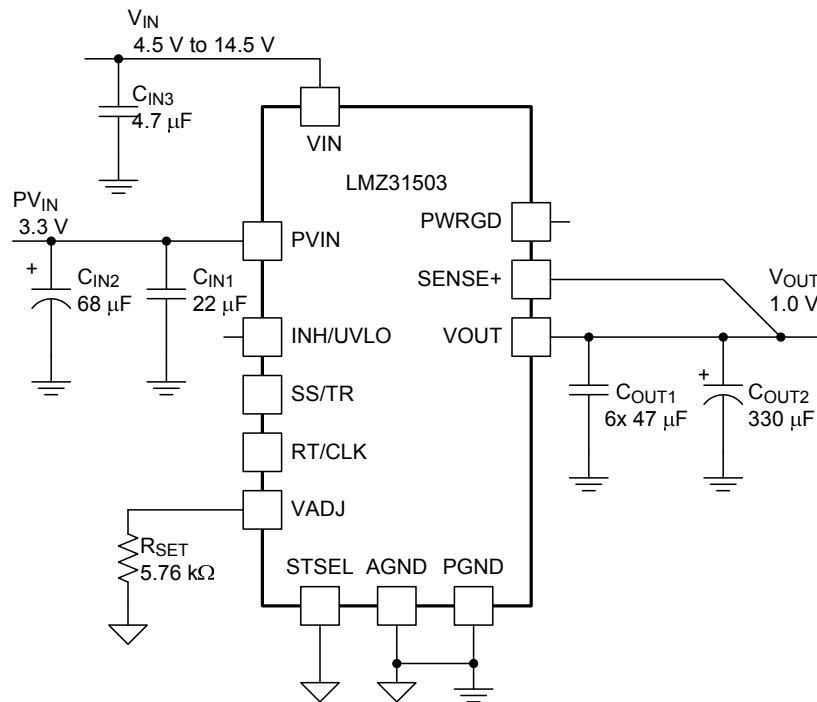

**Figure 26. Typical Schematic**  
**PVIN = 3.3 V, VIN = 4.5 V to 14.5 V, VOUT = 1.0 V**

## VIN and PVIN Input Voltage

The LMZ31503 allows for a variety of applications by using the VIN and PVIN pins together or separately. The VIN voltage supplies the internal control circuits of the device. The PVIN voltage provides the input voltage to the power converter system.

If tied together, the input voltage for the VIN pin and the PVIN pin can range from 4.5 V to 14.5 V. If using the VIN pin separately from the PVIN pin, the VIN pin must be between 4.5 V and 14.5 V, and the PVIN pin can range from as low as 1.6 V to 14.5 V. A voltage divider connected to the INH/UVLO pin can adjust the either input voltage UVLO appropriately. See the [Programmable Undervoltage Lockout \(UVLO\)](#) section of this datasheet for more information.

## Power Good (PWRGD)

The PWRGD pin is an open drain output. Once the voltage on the SENSE+ pin is between 94% and 106% of the set voltage, the PWRGD pin pull-down is released and the pin floats. The recommended pull-up resistor value is between 10 kΩ and 100 kΩ to a voltage source that is 5.5 V or less. The PWRGD pin is in a defined state once VIN is greater than 1.0 V, but with reduced current sinking capability. The PWRGD pin achieves full current sinking capability once the VIN pin is above 4.5V. The PWRGD pin is pulled low when the voltage on SENSE+ is lower than 91% or greater than 109% of the nominal set voltage. Also, the PWRGD pin is pulled low if the input UVLO or thermal shutdown is asserted, the INH pin is pulled low, or the SS/TR pin is below 1.4 V.

## Power-Up Characteristics

When configured as shown in the front page schematic, the LMZ31503 produces a regulated output voltage following the application of a valid input voltage. During the power-up, internal soft-start circuitry slows the rate that the output voltage rises, thereby limiting the amount of in-rush current that can be drawn from the input source. The soft-start circuitry introduces a short time delay from the point that a valid input voltage is recognized. Figure 27 shows the start-up waveforms for a LMZ31503, operating from a 5-V input ( $P_{VIN}=V_{IN}$ ) and with the output voltage adjusted to 1.8 V. Figure 28 shows the start-up waveforms for a LMZ31503 starting up into a pre-biased output voltage. The waveforms were measured with a 2-A constant current load.

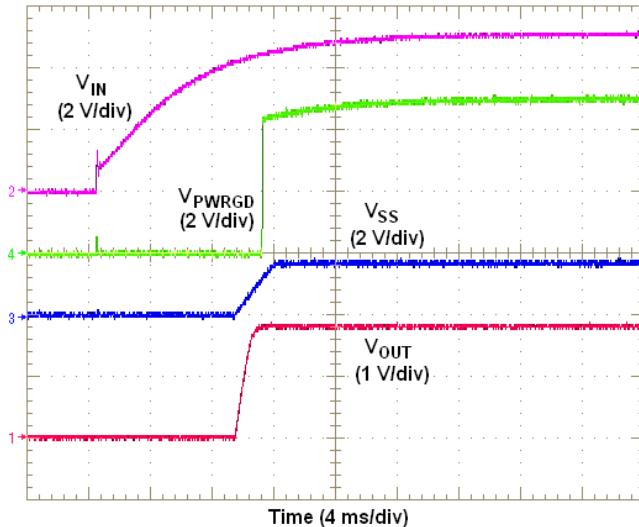

Figure 27. Start-Up Waveforms

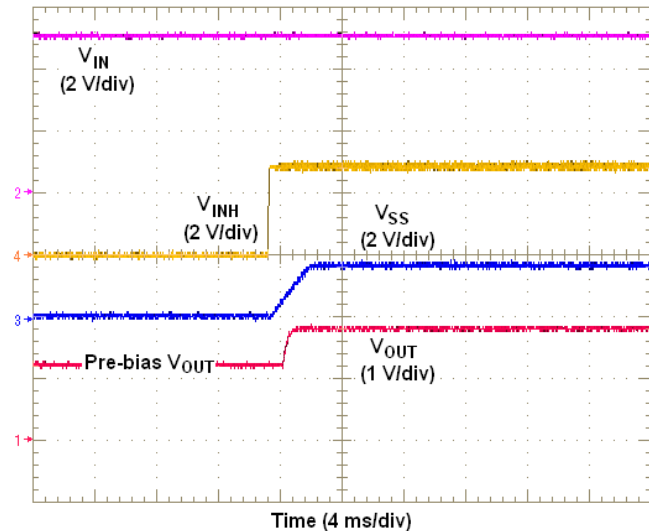

Figure 28. Start-up into Pre-bias

## Pre-Biased Start-Up

The LMZ31503 has been designed to prevent discharging a pre-biased output. During monotonic pre-biased startup, the LMZ31503 does not allow current to sink until the SS/TR pin voltage is higher than 1.4 V.

## Remote Sense

The SENSE+ pin must be connected to  $V_{OUT}$  at the load, or at the device pins.

Connecting the SENSE+ pin to  $V_{OUT}$  at the load improves the load regulation performance of the device by allowing it to compensate for any I-R voltage drop between its output pins and the load. An I-R drop is caused by the high output current flowing through the small amount of pin and trace resistance. This should be limited to a maximum of 300 mV.

### NOTE

The remote sense feature is not designed to compensate for the forward drop of nonlinear or frequency dependent components that may be placed in series with the converter output. Examples include OR-ing diodes, filter inductors, ferrite beads, and fuses. When these components are enclosed by the SENSE+ connection, they are effectively placed inside the regulation control loop, which can adversely affect the stability of the regulator.

### Output On/Off Inhibit (INH)

The INH pin provides electrical on/off control of the device. Once the INH pin voltage exceeds the threshold voltage, the device starts operation. If the INH pin voltage is pulled below the threshold voltage, the regulator stops switching and enters low quiescent current state.

The INH pin has an internal pull-up current source, allowing the user to float the INH pin for enabling the device. If an application requires controlling the INH pin, use an open drain/collector device, or a suitable logic gate to interface with the pin.

Figure 29 shows the typical application of the inhibit function. The Inhibit control has its own internal pull-up to VIN potential. An open-collector or open-drain device is recommended to control this input.

Turning Q1 on applies a low voltage to the inhibit control (INH) pin and disables the output of the supply, shown in Figure 30. If Q1 is turned off, the supply executes a soft-start power-up sequence, as shown in Figure 31. A regulated output voltage is produced within 10 ms. The waveforms were measured with a 2-A constant resistance load.

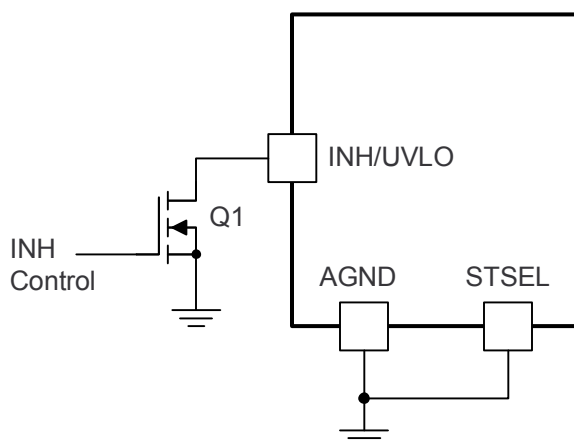

Figure 29. Typical Inhibit Control

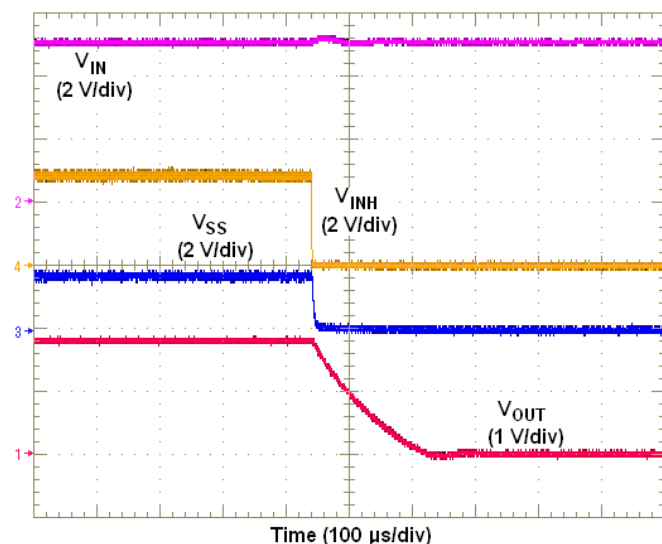

Figure 30. Inhibit Turn-Off

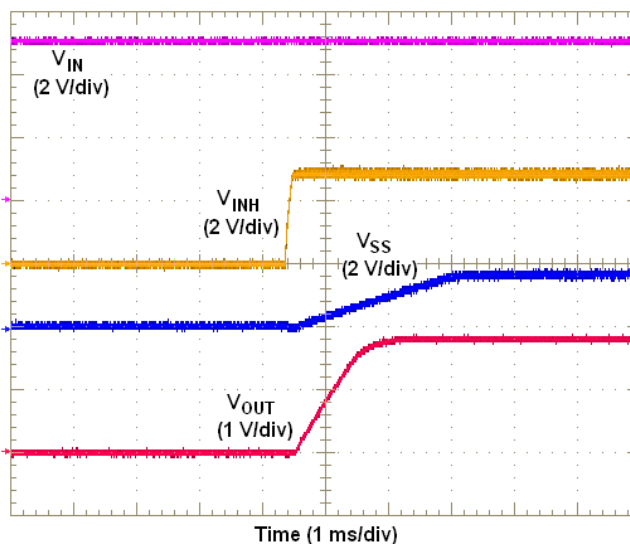

Figure 31. Inhibit Turn-On

## Slow Start (SS/TR)

Connecting the STSEL pin to AGND and leaving SS/TR pin open enables the internal SS capacitor with a slow start interval of approximately 1.1 ms. Adding additional capacitance between the SS pin and AGND increases the slow start time. Table 6 shows an additional SS capacitor connected to the SS/TR pin and the STSEL pin connected to AGND. See Table 6 below for SS capacitor values and timing interval.

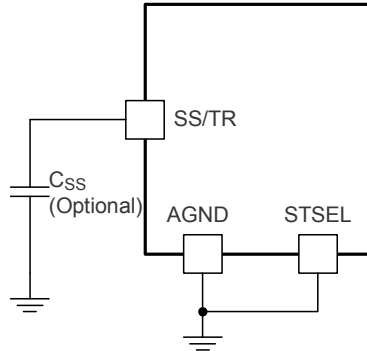

Figure 32. Slow-Start Capacitor ( $C_{SS}$ ) and STSEL Connection

Table 6. Slow-Start Capacitor Values and Slow-Start Time

$C_{SS}$ (pF)	open	2200	4700	10000	15000	22000	25000
SS Time (msec)	1.1	1.9	2.8	4.6	6.4	8.8	9.8

## Overcurrent Protection

For protection against load faults, the LMZ31503 incorporates output overcurrent protection. Applying a load that exceeds the regulator's overcurrent threshold causes the regulated output to shut down. Following shutdown, the output voltage periodically attempts to recover by initiating a soft-start power-up. This is described as a *hiccup* mode of operation, whereby the module continues in a cycle of successive shutdown and power up until the load fault is removed, as shown in Figure 33. During this period, the average current flowing into the fault is significantly reduced. Once the fault is removed, the module automatically recovers and returns to normal operation, as shown in Figure 34.

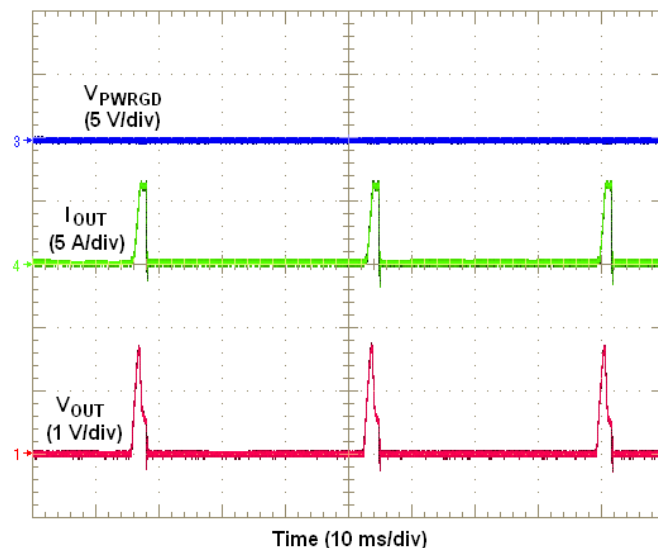

Figure 33. Overcurrent - Hiccup Mode

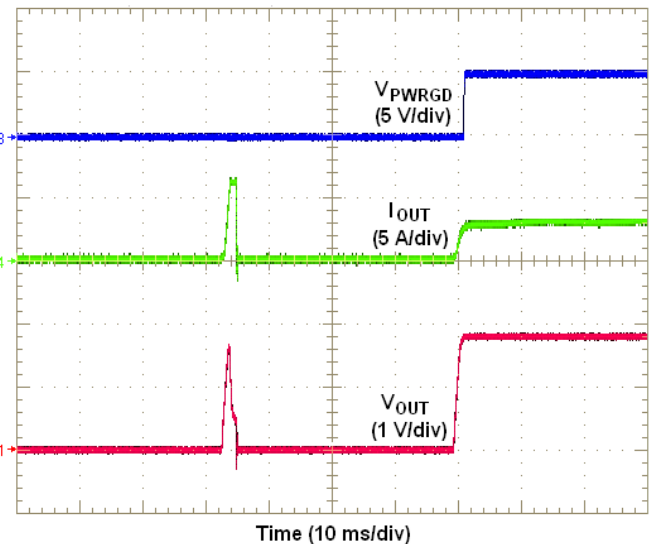

Figure 34. Removal of Overcurrent Condition

## Synchronization (CLK)

An internal phase locked loop (PLL) has been implemented to allow synchronization between 330 kHz and 780 kHz, and to easily switch from RT mode to CLK mode. To implement the synchronization feature, connect a square wave clock signal to the RT/CLK pin with a duty cycle between 20% to 80%. The clock signal amplitude must transition lower than 0.8 V and higher than 2.0 V. The start of the switching cycle is synchronized to the falling edge of RT/CLK pin. In applications where both RT mode and CLK mode are needed, the device can be configured as shown in .

Before the external clock is present, the device works in RT mode and the switching frequency is set by RT resistor ( $R_{RT}$ ). When the external clock is present, the CLK mode overrides the RT mode. The first time the CLK pin is pulled above the RT/CLK high threshold (2.0 V), the device switches from RT mode to th CLK mode and the RT/CLK pin becomes high impedance as the PLL starts to lock onto the frequency of the external clock. It is not recommended to switch from CLK mode back to RT mode because the internal switching frequency drops to 100 kHz and may shut-down due to internal protection circuits before returning to the switching frequency set by the RT resistor.

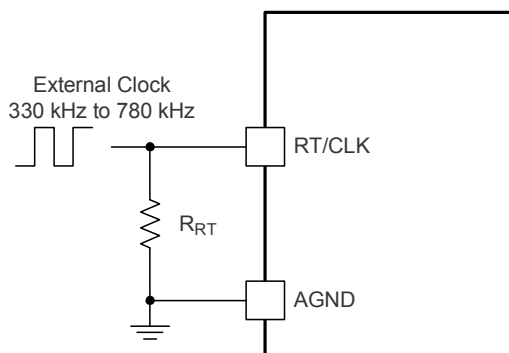

Figure 35. CLK/RT Configuration

The synchronization frequency must be selected based on the output voltages of the devices being synchronized. Table 7 shows the allowable frequencies for a given range of output voltages. For the most efficient solution, always synchronize to the lowest allowable frequency. For example, an application requires synchronizing three LMZ31503 devices with output voltages of 1.2 V, 1.8 V and 2.5 V, all powered from  $P_{VIN} = 12 V$ . Table 7 shows that all three output voltages can be synchronized to frquencies between 480 kHz to 630 kHz. For best efficiency, choose 480 kHz as the sychronization frequency.

Table 7. Synchronization Frequency vs Output Voltage

SYNCHRONIZATION FREQUENCY (kHz)	$R_{RT}$ (k $\Omega$ )	$P_{VIN} = 12 V$		$P_{VIN} = 5 V$	
		$V_{OUT}$ RANGE (V)		$V_{OUT}$ RANGE (V)	
		MIN	MAX	MIN	MAX
330	OPEN	0.8	1.5	0.8	4.3
380	1000	0.8	1.7		
430	499	0.8	2.1		
480	324	0.9	2.5		
530	237	1.0	2.9		
580	191	1.1	3.2		
630	158	1.2	3.7		
680	137	1.3	4.1		
730	118	1.4	4.7		
780	105	1.5	5.5		

### Sequencing (SS/TR)

Many of the common power supply sequencing methods can be implemented using the SS/TR, INH and PWRGD pins. The sequential method is illustrated in Figure 36 using two LMZ31503 devices. The PWRGD pin of the first device is coupled to the INH pin of the second device which enables the second power supply once the primary supply reaches regulation. Figure 37 shows sequential turn-on waveforms of two LMZ31503 devices.

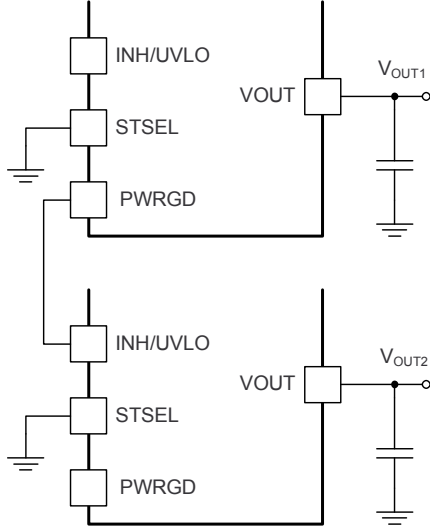

Figure 36. Sequencing Schematic

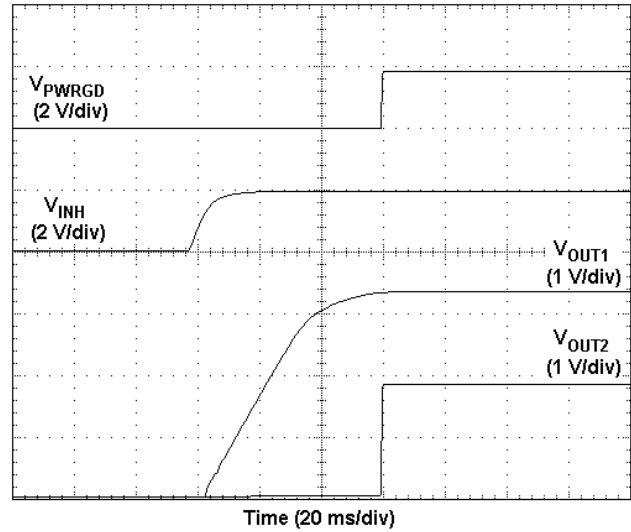

Figure 37. Sequencing Waveforms

Simultaneous power supply sequencing can be implemented by connecting the resistor network of R1 and R2 shown in Figure 38 to the output of the power supply that needs to be tracked or to another voltage reference source. Figure 39 shows simultaneous turn-on waveforms of two LMZ31503 devices. Use Equation 2 and Equation 3 to calculate the values of R1 and R2.

$$R1 = \frac{(V_{OUT2} \times 12.6)}{0.8} \text{ (k}\Omega\text{)}$$

(2)

$$R2 = \frac{0.8 \times R1}{(V_{OUT2} - 0.8)} \text{ (k}\Omega\text{)}$$

(3)

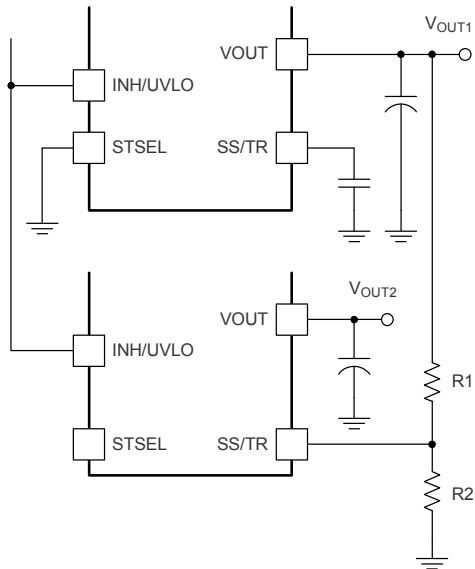

Figure 38. Simultaneous Tracking Schematic

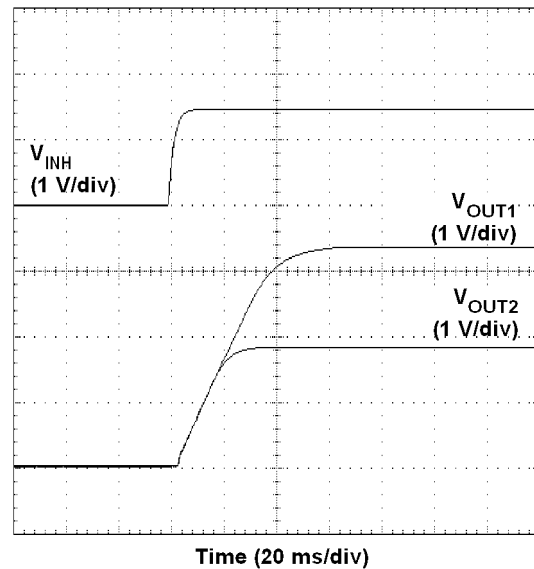

Figure 39. Simultaneous Tracking Waveforms

### Programmable Undervoltage Lockout (UVLO)

The LMZ31503 implements internal UVLO circuitry on the VIN pin. The device is disabled when the VIN pin voltage falls below the internal VIN UVLO threshold. The internal VIN UVLO rising threshold is 4.5 V(max) with a typical hysteresis of 150 mV.

If an application requires either a higher UVLO threshold on the VIN pin or a higher UVLO threshold for a combined VIN and PVIN, then the UVLO pin can be configured as shown in Figure 40 or Figure 41. Table 8 lists standard values for  $R_{UVLO1}$  and  $R_{UVLO2}$  to adjust the VIN UVLO voltage up.

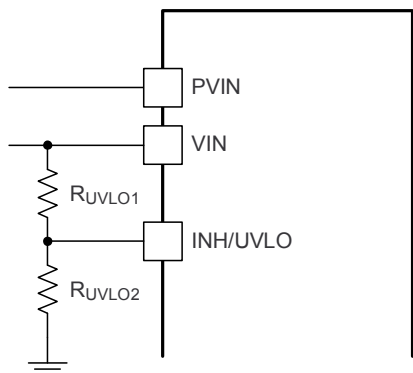

Figure 40. Adjustable VIN UVLO

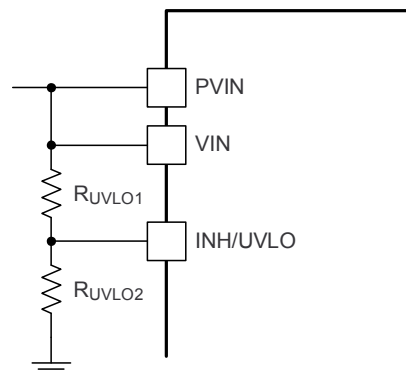

Figure 41. Adjustable VIN and PVIN Undervoltage Lockout

Table 8. Standard Resistor values for Adjusting VIN UVLO

VIN UVLO (V)	5.0	5.5	6.0	6.5	7.0	7.5	8.0	8.5	9.0	9.5	10.0
$R_{UVLO1}$ (k $\Omega$ )	68.1	68.1	68.1	68.1	68.1	68.1	68.1	68.1	68.1	68.1	68.1
$R_{UVLO2}$ (k $\Omega$ )	21.5	18.7	16.9	15.4	14.0	13.0	12.1	11.3	10.5	9.76	9.31
Hysteresis (mV)	400	415	430	450	465	480	500	515	530	550	565

For a split rail application, if a secondary UVLO on PVIN is required, VIN must be  $\geq 4.5V$ . Figure 42 shows the PVIN UVLO configuration. Use Table 9 to select  $R_{UVLO1}$  and  $R_{UVLO2}$  for PVIN. If PVIN UVLO is set for less than 3.0 V, a 5.1-V zener diode should be added to clamp the voltage on the UVLO pin below 6 V.

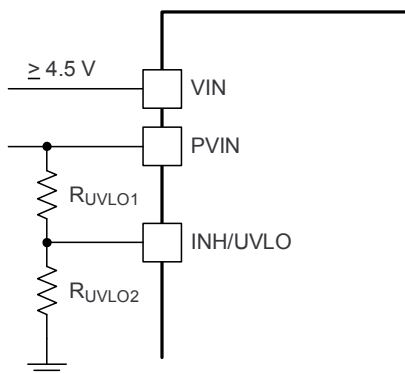

Figure 42. Adjustable PVIN Undervoltage Lockout, (VIN  $\geq 4.5$  V)

Table 9. Standard Resistor Values for Adjusting PVIN UVLO, (VIN  $\geq 4.5$  V)

PVIN UVLO (V)	2.0	2.5	3.0	3.5	4.0	4.5	
$R_{UVLO1}$ (k $\Omega$ )	68.1	68.1	68.1	68.1	68.1	68.1	For higher PVIN UVLO voltages see Table UV for resistor values
$R_{UVLO2}$ (k $\Omega$ )	95.3	60.4	44.2	34.8	28.7	24.3	
Hysteresis (mV)	300	315	335	350	365	385	

## Thermal Shutdown

The internal thermal shutdown circuitry forces the device to stop switching if the junction temperature exceeds 175°C typically. The device reinitiates the power up sequence when the junction temperature drops below 165°C typically.

## Layout Considerations

To achieve optimal electrical and thermal performance, an optimized PCB layout is required. Figure 43 and Figure 44 show two layers of a typical PCB layout. Some considerations for an optimized layout are:

- Use large copper areas for power planes (VIN, VOUT, and PGND) to minimize conduction loss and thermal stress.
- Place ceramic input and output capacitors close to the module pins to minimize high frequency noise.
- Locate additional output capacitors between the ceramic capacitor and the load.
- Place a dedicated AGND copper area beneath the LMZ31503.
- Isolate the PH copper area from the VOUT copper area using the AGND copper area.
- Connect the AGND and PGND copper area at one point; near the output capacitors.
- Place  $R_{SET}$ ,  $R_{RT}$ , and  $C_{SS}$  as close as possible to their respective pins.
- Use multiple vias to connect the power planes to internal layers.

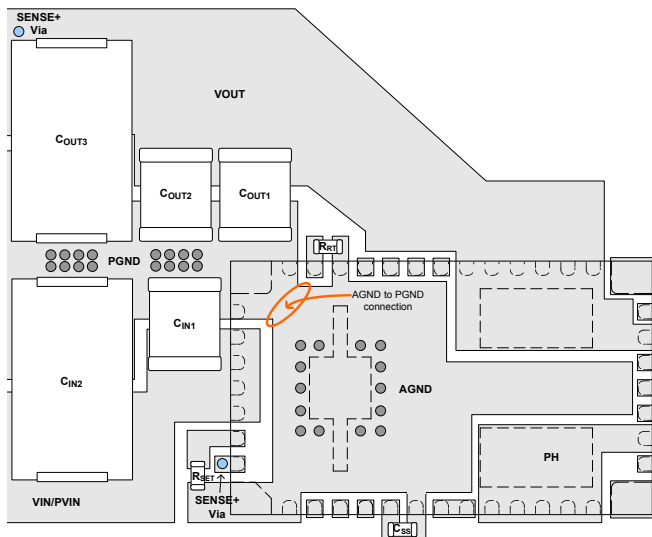

**Figure 43. Typical Top-Layer Recommended Layout**

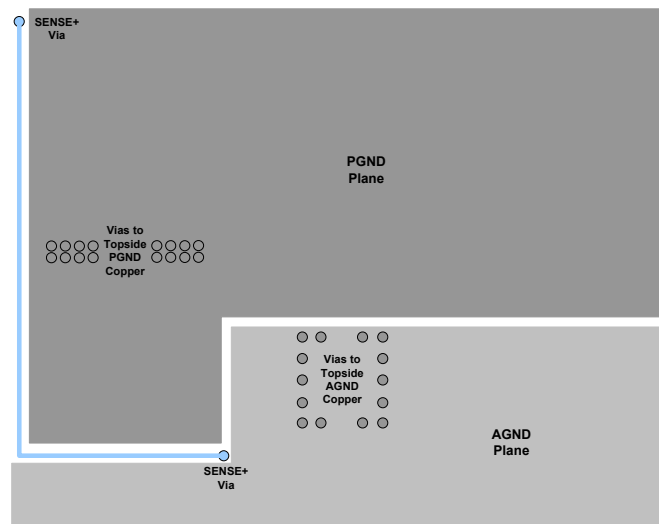

**Figure 44. Typical GND-Layer Recommended Layout**

**EMI**

The LMZ31503 is compliant with EN55022 Class B radiated emissions. [Figure 45](#) and [Figure 46](#) show typical examples of radiated emissions plots for the LMZ31503 operating from 5V and 12V respectively. Both graphs include the plots of the antenna in the horizontal and vertical positions.

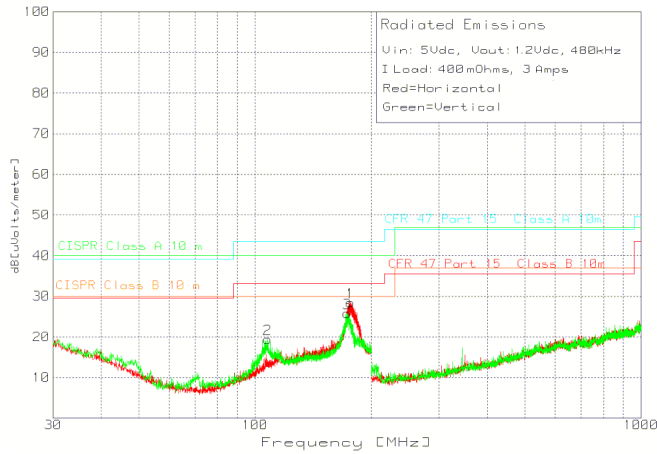

**Figure 45. Radiated Emissions 5-V Input, 1.2-V Output, 3-A Load (EN55022 Class B)**

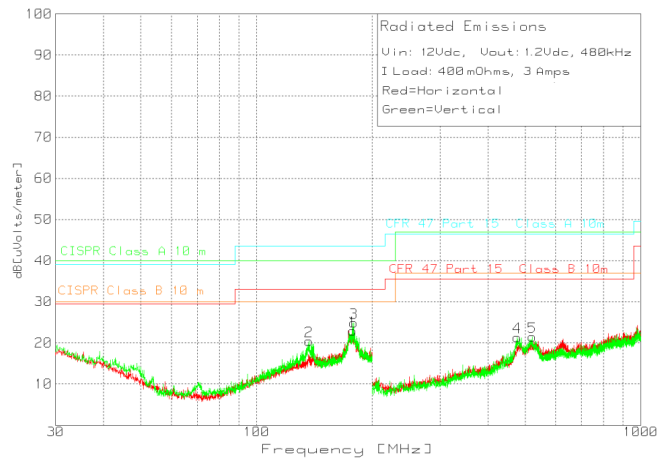

**Figure 46. Radiated Emissions 12-V Input, 1.2-V Output, 3-A Load (EN55022 Class B)**

**PACKAGING INFORMATION**

Orderable Device	Status (1)	Package Type	Package Drawing	Pins	Package Qty	Eco Plan (2)	Lead/Ball Finish (6)	MSL Peak Temp (3)	Op Temp (°C)	Device Marking (4/5)	Samples
LMZ31503RUQR	ACTIVE	B1QFN	RUQ	47	500	Green (RoHS & no Sb/Br)	CU NIPDAU	Level-3-260C-168 HR	-40 to 85	(54320 ~ LMZ31503)	<a href="#">Samples</a>
LMZ31503RUQT	ACTIVE	B1QFN	RUQ	47	250	Green (RoHS & no Sb/Br)	CU NIPDAU	Level-3-260C-168 HR	-40 to 85	(54320 ~ LMZ31503)	<a href="#">Samples</a>

(1) The marketing status values are defined as follows:

**ACTIVE:** Product device recommended for new designs.

**LIFEBUY:** TI has announced that the device will be discontinued, and a lifetime-buy period is in effect.

**NRND:** Not recommended for new designs. Device is in production to support existing customers, but TI does not recommend using this part in a new design.

**PREVIEW:** Device has been announced but is not in production. Samples may or may not be available.

**OBSELETE:** TI has discontinued the production of the device.

(2) Eco Plan - The planned eco-friendly classification: Pb-Free (RoHS), Pb-Free (RoHS Exempt), or Green (RoHS & no Sb/Br) - please check <http://www.ti.com/productcontent> for the latest availability information and additional product content details.

**TBD:** The Pb-Free/Green conversion plan has not been defined.

**Pb-Free (RoHS):** TI's terms "Lead-Free" or "Pb-Free" mean semiconductor products that are compatible with the current RoHS requirements for all 6 substances, including the requirement that lead not exceed 0.1% by weight in homogeneous materials. Where designed to be soldered at high temperatures, TI Pb-Free products are suitable for use in specified lead-free processes.

**Pb-Free (RoHS Exempt):** This component has a RoHS exemption for either 1) lead-based flip-chip solder bumps used between the die and package, or 2) lead-based die adhesive used between the die and leadframe. The component is otherwise considered Pb-Free (RoHS compatible) as defined above.

**Green (RoHS & no Sb/Br):** TI defines "Green" to mean Pb-Free (RoHS compatible), and free of Bromine (Br) and Antimony (Sb) based flame retardants (Br or Sb do not exceed 0.1% by weight in homogeneous material)

(3) MSL, Peak Temp. - The Moisture Sensitivity Level rating according to the JEDEC industry standard classifications, and peak solder temperature.

(4) There may be additional marking, which relates to the logo, the lot trace code information, or the environmental category on the device.

(5) Multiple Device Markings will be inside parentheses. Only one Device Marking contained in parentheses and separated by a "~" will appear on a device. If a line is indented then it is a continuation of the previous line and the two combined represent the entire Device Marking for that device.

(6) Lead/Ball Finish - Orderable Devices may have multiple material finish options. Finish options are separated by a vertical ruled line. Lead/Ball Finish values may wrap to two lines if the finish value exceeds the maximum column width.

**Important Information and Disclaimer:**The information provided on this page represents TI's knowledge and belief as of the date that it is provided. TI bases its knowledge and belief on information provided by third parties, and makes no representation or warranty as to the accuracy of such information. Efforts are underway to better integrate information from third parties. TI has taken and continues to take reasonable steps to provide representative and accurate information but may not have conducted destructive testing or chemical analysis on incoming materials and chemicals. TI and TI suppliers consider certain information to be proprietary, and thus CAS numbers and other limited information may not be available for release.

In no event shall TI's liability arising out of such information exceed the total purchase price of the TI part(s) at issue in this document sold by TI to Customer on an annual basis.

## TAPE AND REEL INFORMATION



### QUADRANT ASSIGNMENTS FOR PIN 1 ORIENTATION IN TAPE



\*All dimensions are nominal

Device	Package Type	Package Drawing	Pins	SPQ	Reel Diameter (mm)	Reel Width W1 (mm)	A0 (mm)	B0 (mm)	K0 (mm)	P1 (mm)	W (mm)	Pin1 Quadrant
LMZ31503RUQR	B1QFN	RUQ	47	500	330.0	24.4	9.35	15.35	3.1	16.0	24.0	Q1
LMZ31503RUQT	B1QFN	RUQ	47	250	330.0	24.4	9.35	15.35	3.1	16.0	24.0	Q1

TAPE AND REEL BOX DIMENSIONS



\*All dimensions are nominal

Device	Package Type	Package Drawing	Pins	SPQ	Length (mm)	Width (mm)	Height (mm)
LMZ31503RUQR	B1QFN	RUQ	47	500	383.0	353.0	58.0
LMZ31503RUQT	B1QFN	RUQ	47	250	383.0	353.0	58.0

# MECHANICAL DATA

RUQ (R-PB1QFN-N47)

PLASTIC QUAD FLATPACK NO-LEAD

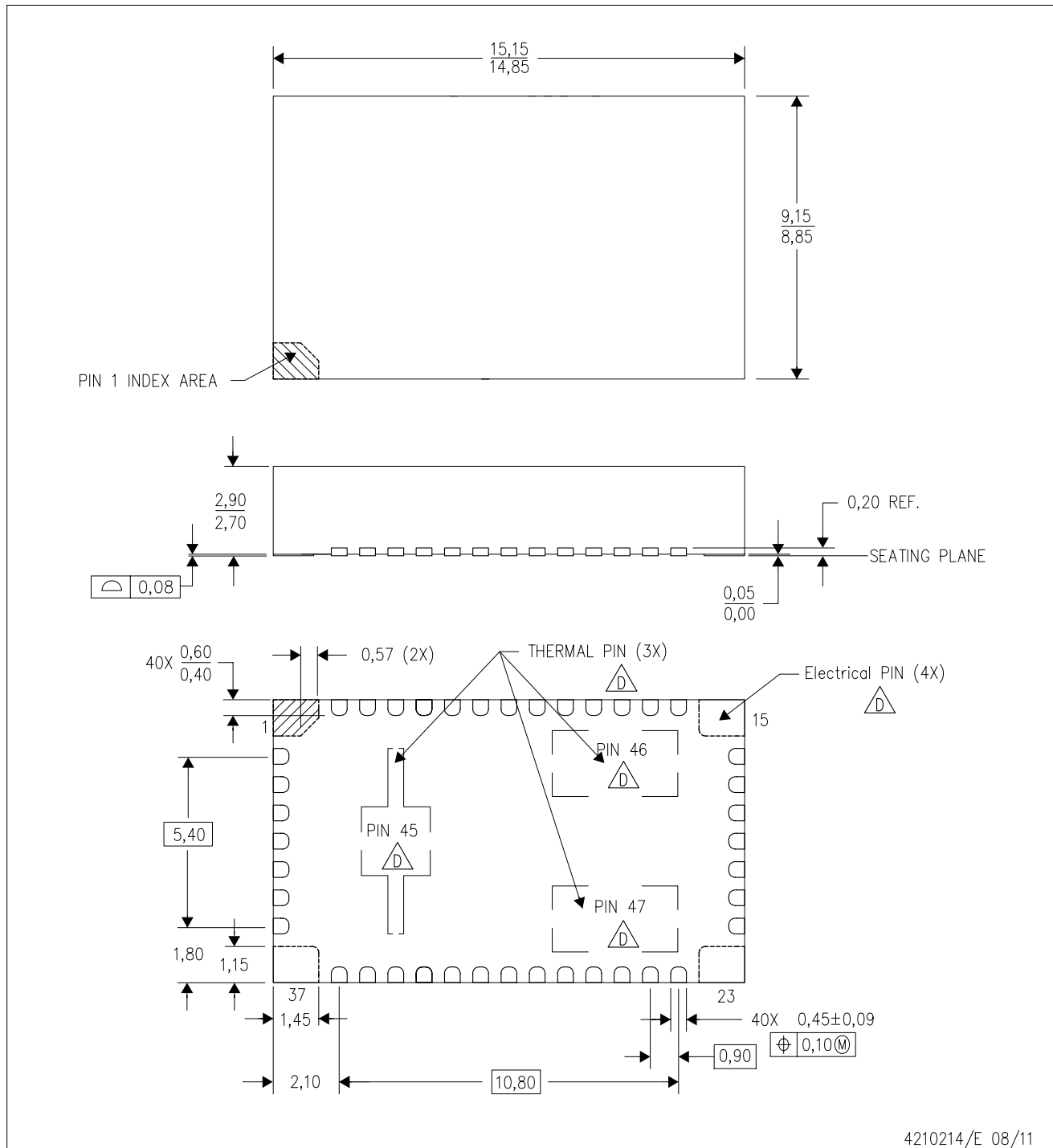

- NOTES:
- A. All linear dimensions are in millimeters. Dimensioning and tolerancing per ASME Y14.5M-1994.
  - B. This drawing is subject to change without notice.
  - C. Quad Flatpack, No-leads (QFN) package configuration.
  - D. The package thermal pad must be soldered to the board for thermal and mechanical performance.
  - E. See the additional figure in the Product Data Sheet for details regarding the exposed thermal pad features and dimensions.
  - F. The package thermal performance may be enhanced by bonding the thermal pad to an external thermal plane.





RUQ (R-PB1QFN-N47)

PLASTIC QUAD FLATPACK NO-LEAD

Example Stencil Design (Note E)  
Stencil Thickness = 0,125mm

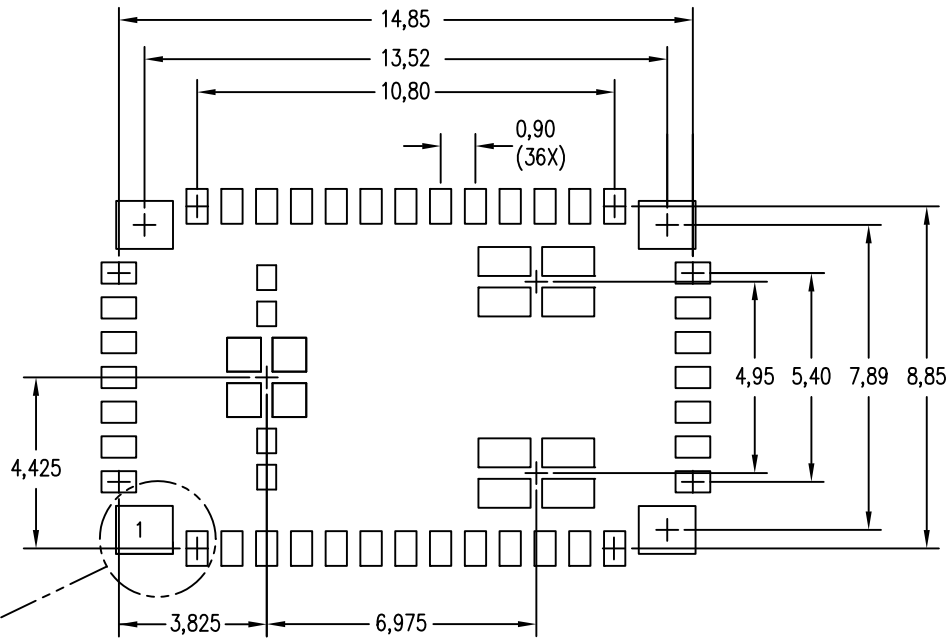

60% solder coverage on center pads

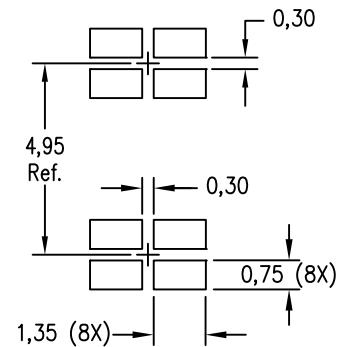
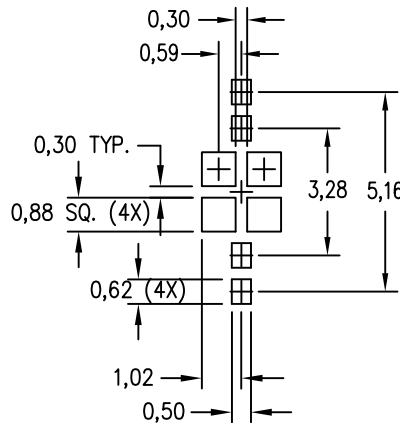
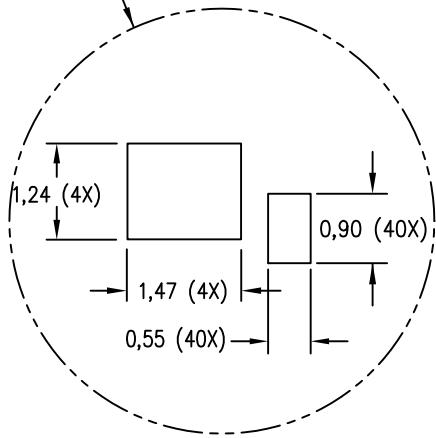

4210717-3/1 10/14

NOTES:

- E. Laser cutting apertures with trapezoidal walls and also rounding corners will offer better paste release. Customers should contact their board assembly site for stencil design recommendations. Refer to IPC 7525 for stencil design considerations.

## IMPORTANT NOTICE

Texas Instruments Incorporated and its subsidiaries (TI) reserve the right to make corrections, enhancements, improvements and other changes to its semiconductor products and services per JESD46, latest issue, and to discontinue any product or service per JESD48, latest issue. Buyers should obtain the latest relevant information before placing orders and should verify that such information is current and complete. All semiconductor products (also referred to herein as "components") are sold subject to TI's terms and conditions of sale supplied at the time of order acknowledgment.

TI warrants performance of its components to the specifications applicable at the time of sale, in accordance with the warranty in TI's terms and conditions of sale of semiconductor products. Testing and other quality control techniques are used to the extent TI deems necessary to support this warranty. Except where mandated by applicable law, testing of all parameters of each component is not necessarily performed.

TI assumes no liability for applications assistance or the design of Buyers' products. Buyers are responsible for their products and applications using TI components. To minimize the risks associated with Buyers' products and applications, Buyers should provide adequate design and operating safeguards.

TI does not warrant or represent that any license, either express or implied, is granted under any patent right, copyright, mask work right, or other intellectual property right relating to any combination, machine, or process in which TI components or services are used. Information published by TI regarding third-party products or services does not constitute a license to use such products or services or a warranty or endorsement thereof. Use of such information may require a license from a third party under the patents or other intellectual property of the third party, or a license from TI under the patents or other intellectual property of TI.

Reproduction of significant portions of TI information in TI data books or data sheets is permissible only if reproduction is without alteration and is accompanied by all associated warranties, conditions, limitations, and notices. TI is not responsible or liable for such altered documentation. Information of third parties may be subject to additional restrictions.

Resale of TI components or services with statements different from or beyond the parameters stated by TI for that component or service voids all express and any implied warranties for the associated TI component or service and is an unfair and deceptive business practice. TI is not responsible or liable for any such statements.

Buyer acknowledges and agrees that it is solely responsible for compliance with all legal, regulatory and safety-related requirements concerning its products, and any use of TI components in its applications, notwithstanding any applications-related information or support that may be provided by TI. Buyer represents and agrees that it has all the necessary expertise to create and implement safeguards which anticipate dangerous consequences of failures, monitor failures and their consequences, lessen the likelihood of failures that might cause harm and take appropriate remedial actions. Buyer will fully indemnify TI and its representatives against any damages arising out of the use of any TI components in safety-critical applications.

In some cases, TI components may be promoted specifically to facilitate safety-related applications. With such components, TI's goal is to help enable customers to design and create their own end-product solutions that meet applicable functional safety standards and requirements. Nonetheless, such components are subject to these terms.

No TI components are authorized for use in FDA Class III (or similar life-critical medical equipment) unless authorized officers of the parties have executed a special agreement specifically governing such use.

Only those TI components which TI has specifically designated as military grade or "enhanced plastic" are designed and intended for use in military/aerospace applications or environments. Buyer acknowledges and agrees that any military or aerospace use of TI components which have **not** been so designated is solely at the Buyer's risk, and that Buyer is solely responsible for compliance with all legal and regulatory requirements in connection with such use.

TI has specifically designated certain components as meeting ISO/TS16949 requirements, mainly for automotive use. In any case of use of non-designated products, TI will not be responsible for any failure to meet ISO/TS16949.

### Products

Audio	<a href="http://www.ti.com/audio">www.ti.com/audio</a>
Amplifiers	<a href="http://amplifier.ti.com">amplifier.ti.com</a>
Data Converters	<a href="http://dataconverter.ti.com">dataconverter.ti.com</a>
DLP® Products	<a href="http://www.dlp.com">www.dlp.com</a>
DSP	<a href="http://dsp.ti.com">dsp.ti.com</a>
Clocks and Timers	<a href="http://www.ti.com/clocks">www.ti.com/clocks</a>
Interface	<a href="http://interface.ti.com">interface.ti.com</a>
Logic	<a href="http://logic.ti.com">logic.ti.com</a>
Power Mgmt	<a href="http://power.ti.com">power.ti.com</a>
Microcontrollers	<a href="http://microcontroller.ti.com">microcontroller.ti.com</a>
RFID	<a href="http://www.ti-rfid.com">www.ti-rfid.com</a>
OMAP Applications Processors	<a href="http://www.ti.com/omap">www.ti.com/omap</a>
Wireless Connectivity	<a href="http://www.ti.com/wirelessconnectivity">www.ti.com/wirelessconnectivity</a>

### Applications

Automotive and Transportation	<a href="http://www.ti.com/automotive">www.ti.com/automotive</a>
Communications and Telecom	<a href="http://www.ti.com/communications">www.ti.com/communications</a>
Computers and Peripherals	<a href="http://www.ti.com/computers">www.ti.com/computers</a>
Consumer Electronics	<a href="http://www.ti.com/consumer-apps">www.ti.com/consumer-apps</a>
Energy and Lighting	<a href="http://www.ti.com/energy">www.ti.com/energy</a>
Industrial	<a href="http://www.ti.com/industrial">www.ti.com/industrial</a>
Medical	<a href="http://www.ti.com/medical">www.ti.com/medical</a>
Security	<a href="http://www.ti.com/security">www.ti.com/security</a>
Space, Avionics and Defense	<a href="http://www.ti.com/space-avionics-defense">www.ti.com/space-avionics-defense</a>
Video and Imaging	<a href="http://www.ti.com/video">www.ti.com/video</a>

### TI E2E Community

[e2e.ti.com](http://e2e.ti.com)