

# International Rectifier

## 301U(R) SERIES

### STANDARD RECOVERY DIODES

### Stud Version

#### Features

- Wide current range
- High voltage ratings up to 2500V
- High surge current capabilities
- Stud cathode and stud anode version

300A

#### Typical Applications

- Converters
- Power supplies
- Machine tool controls
- High power drives
- Medium traction applications

#### Major Ratings and Characteristics

Parameters	301U(R)		Units
	80 to 200	250	
$I_{F(AV)}$	330	300	A
@ $T_C$	120	120	°C
$I_{F(RMS)}$	520	470	A
$I_{FSM}$	@ 50Hz	8250	A
	@ 60Hz	8640	A
$I^2t$	@ 50Hz	340	KA <sup>2</sup> s
	@ 60Hz	311	KA <sup>2</sup> s
$V_{RRM}$ range	800 to 2000	2500	V
$T_J$	- 40 to 180	- 40 to 180	°C

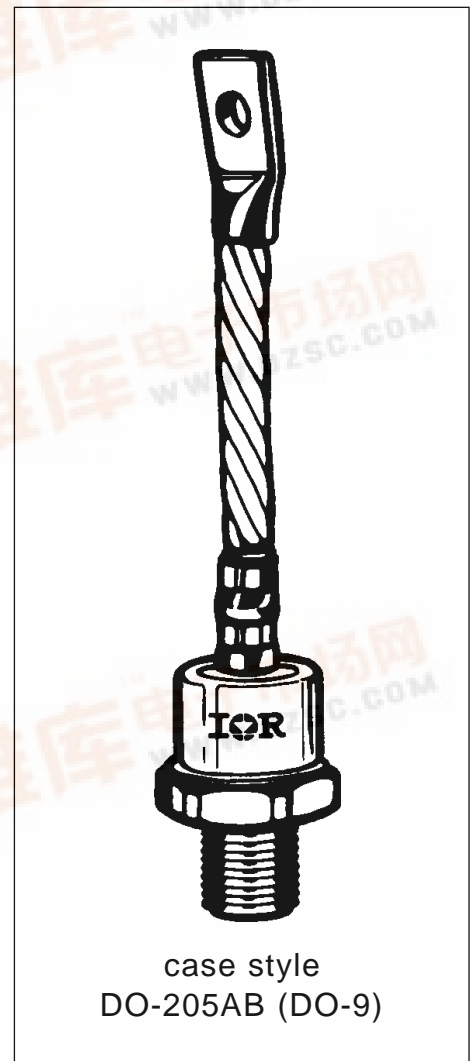

## 301U(R) Series

### ELECTRICAL SPECIFICATIONS

#### Voltage Ratings

Type number	Voltage Code	$V_{RRM}$ , maximum repetitive peak reverse voltage V	$V_{RSM}$ , maximum non-repetitive peak rev. voltage V	$I_{RRM}$ max. @ $T_J = T_J$ max. mA
301U(R)	80	800	900	15
	120	1200	1300	
	160	1600	1700	
	200	2000	2100	
	250	2500	2600	

#### Forward Conduction

Parameter	301U(R)		Units	Conditions
	80 to 200	250		
$I_{F(AV)}$ Max. average forward current @ Case temperature	330	300	A	180° conduction, half sine wave
	120	120	°C	
$I_{F(RMS)}$ Max. RMS forward current	520	470	A	DC @ $T_C = 115^\circ\text{C}$ (08 to 20), $T_C = 102^\circ\text{C}$ (25)
$I_{FSM}$ Max. peak, one-cycle forward, non-repetitive surge current	8250	6050	A	t = 10ms No voltage
	8640	6335		t = 8.3ms reapplied
	6940	5090		t = 10ms 100% $V_{RRM}$
	7270	5330		t = 8.3ms reapplied
$I^2t$ Maximum $I^2t$ for fusing	340	183	KA <sup>2</sup> s	t = 10ms No voltage
	311	167		t = 8.3ms reapplied
	241	129		t = 10ms 100% $V_{RRM}$
	220	118		t = 8.3ms reapplied
$I^2\sqrt{t}$ Maximum $I^2\sqrt{t}$ for fusing	3400	1830	KA <sup>2</sup> /s	t = 0.1 to 10ms, no voltage reapplied
$V_{F(TO)1}$ Low level value of threshold voltage	0.77	0.90	V	( $16.7\% \times \pi \times I_{F(AV)} < I < \pi \times I_{F(AV)}$ ), $T_J = T_J$ max.
$V_{F(TO)2}$ High level value of threshold voltage	0.84	0.97		( $I > \pi \times I_{F(AV)}$ ), $T_J = T_J$ max.
$r_{f1}$ Low level value of forward slope resistance	0.49	0.59	mΩ	( $16.7\% \times \pi \times I_{F(AV)} < I < \pi \times I_{F(AV)}$ ), $T_J = T_J$ max.
$r_{f2}$ High level value of forward slope resistance	0.49	0.55		( $I > \pi \times I_{F(AV)}$ ), $T_J = T_J$ max.
$V_{FM}$ Max. forward voltage drop	1.22	1.46	V	$I_{pk} = 942\text{A}$ , $T_J = T_J$ max, $t_p = 10\text{ms}$ sinusoidal wave

Thermal and Mechanical Specifications

Parameter	301U(R)	Units	Conditions
T <sub>J</sub> Max. junction operating temperature range	-40 to 180	°C	
T <sub>stg</sub> Max. storage temperature range	-40 to 200		
R <sub>thJC</sub> Max. thermal resistance, junction to case	0.14	K/W	DC operation
R <sub>thCS</sub> Max. thermal resistance, case to heatsink	0.08		Mounting surface, smooth, flat and greased
T Max. allowed mounting torque +0 -20%	37	Nm	Not lubricated threads
	28		Lubricated threads
wt Weight	301U	g	
	303U		
	305U		
	307U		
	309U		
Case style	DO-205AB (DO-9)		See Outline Table

$\Delta R_{thJC}$  Conduction

(The following table shows the increment of thermal resistance R<sub>thJC</sub> when devices operate at different conduction angles than DC)

Conduction angle	Sinusoidal conduction		Rectangular conduction		Units	Conditions
	80 to 200	250	00 to 200	250		
180°	0.015	0.015	0.011	0.011	K/W	T <sub>J</sub> = T <sub>J</sub> max.
120°	0.018	0.018	0.019	0.019		
90°	0.023	0.023	0.025	0.025		
60°	0.034	0.034	0.035	0.035		
30°	0.056	0.056	0.057	0.057		

Ordering Information Table

Device Code

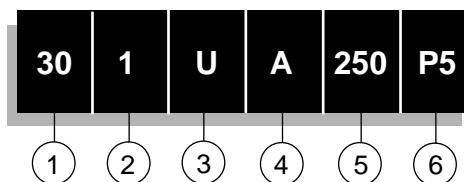

- 1** - 30 = Essential Part Number
- 2** - 1 = Standard Device
  - 3 = Top Threaded version
  - 5 = Type for rotating application with Top Threaded version 3/8 16UNC-2A
  - 7 = Type for rotating application with flexible lead
  - 9 = Type for rotating application with Top Threaded version 3/8 24UNF
- 3** - U = Stud Normal Polarity (Cathode to Stud)  
UR = Stud Reverse Polarity (Anode to Stud)
- 4** - A = Max. Leakage selection I<sub>RRM</sub> = 2mA T<sub>J</sub> = 25°C  
None = Std. Leakage selection I<sub>RRM</sub> = 10mA T<sub>J</sub> = 25°C
- 5** - Voltage code: Code x 10 = V<sub>RRM</sub> (See Voltage Ratings table)
- 6** - P. = Forward selection  
None = Standard Forward selection

RANGE	I <sub>FM</sub> T <sub>J</sub> = 25°C (A)	V <sub>FM</sub> min. (V)	V <sub>FM</sub> max. (V)
P2 *	1000	1.16	1.25
P3 *		1.26	1.30
P4		1.31	1.40
P5		1.41	1.45

\* 2500V not available

# 301U(R) Series

## Outline Table

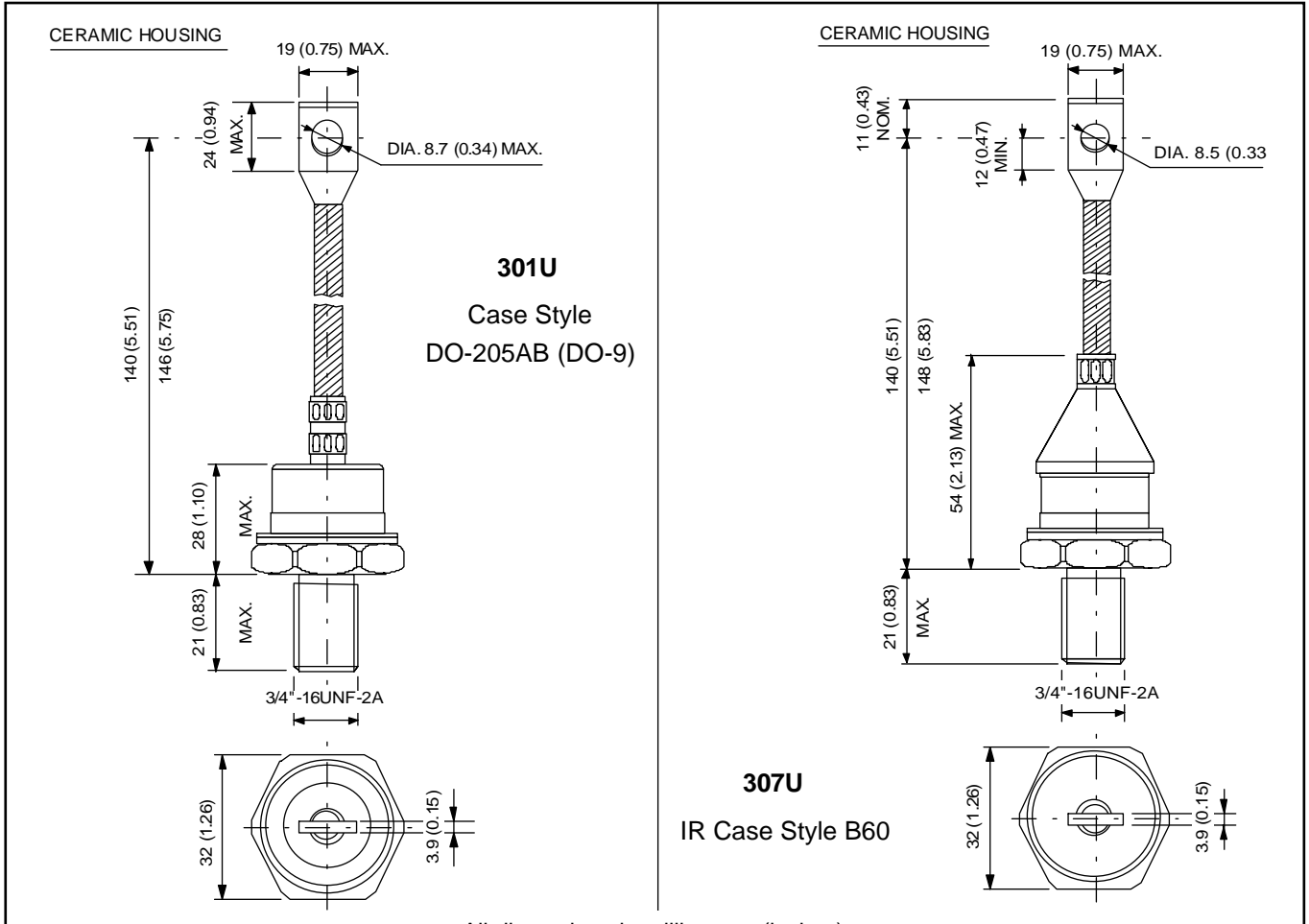

All dimensions in millimeters (inches)

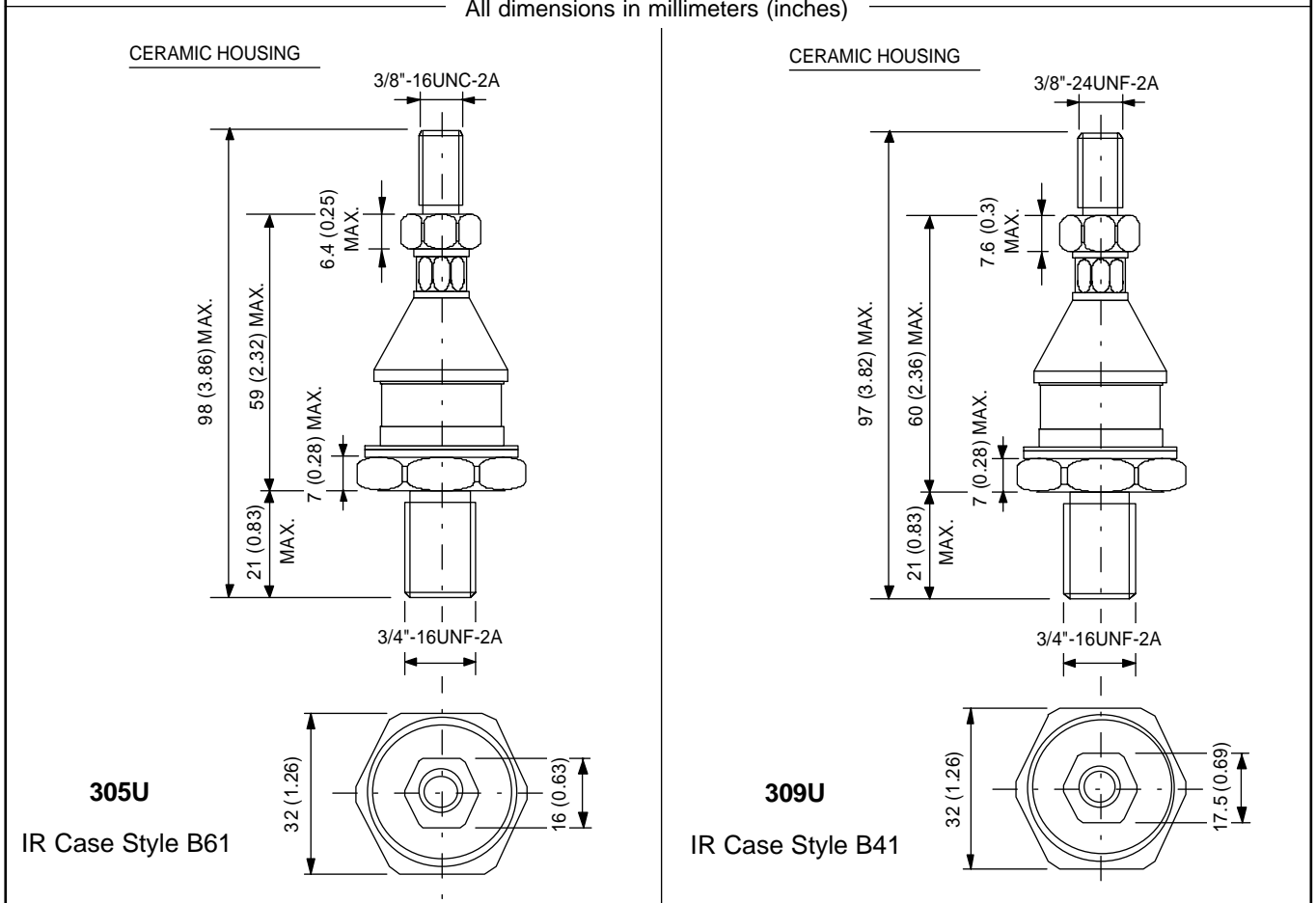

Outline Table

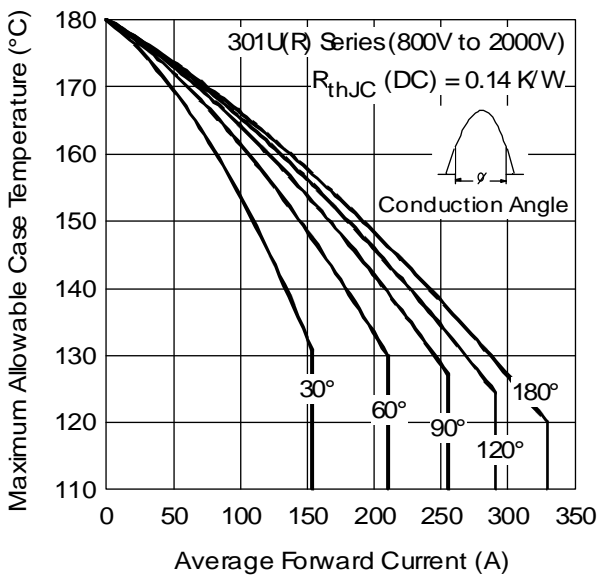
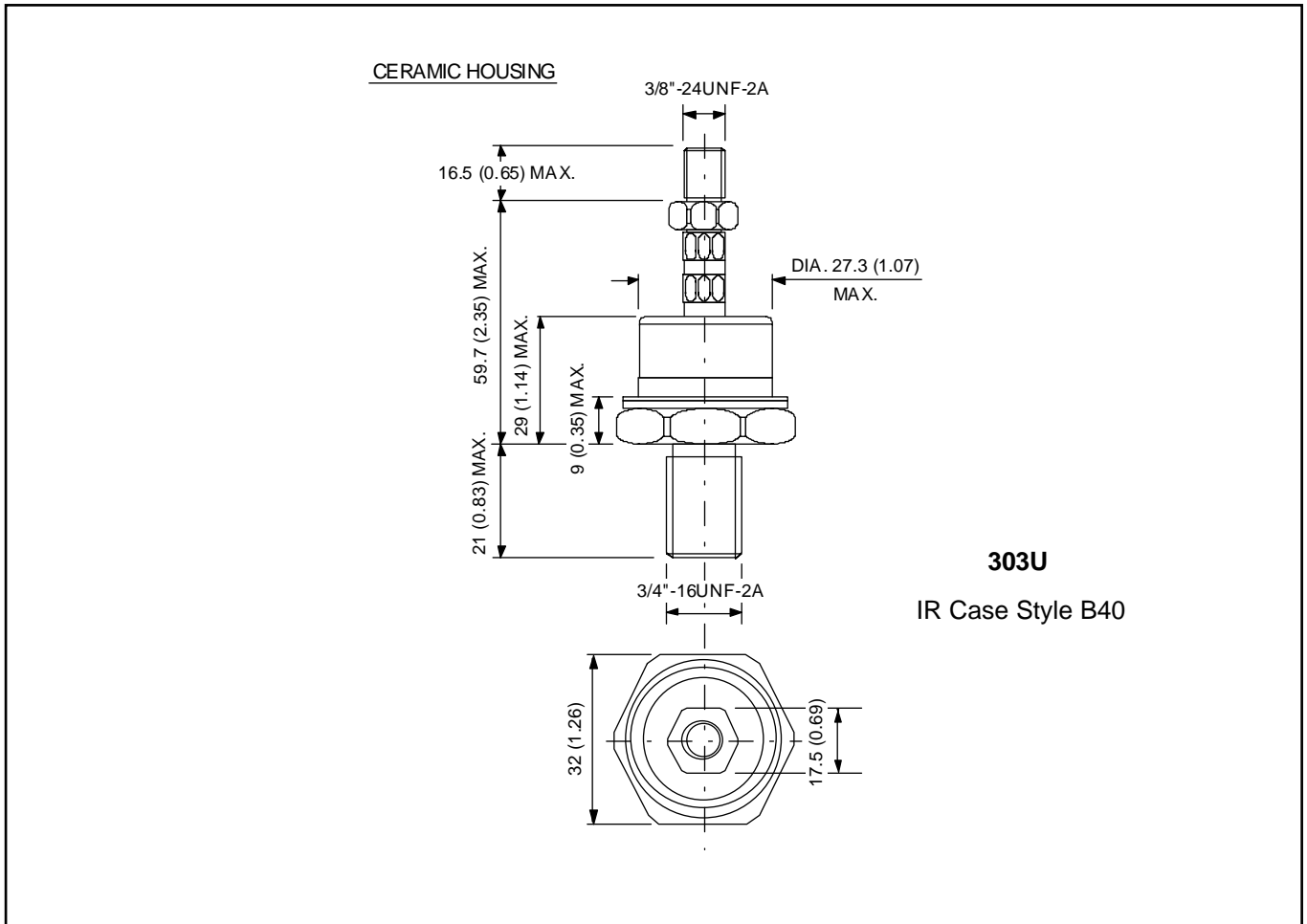

Fig. 1 - Current Ratings Characteristics

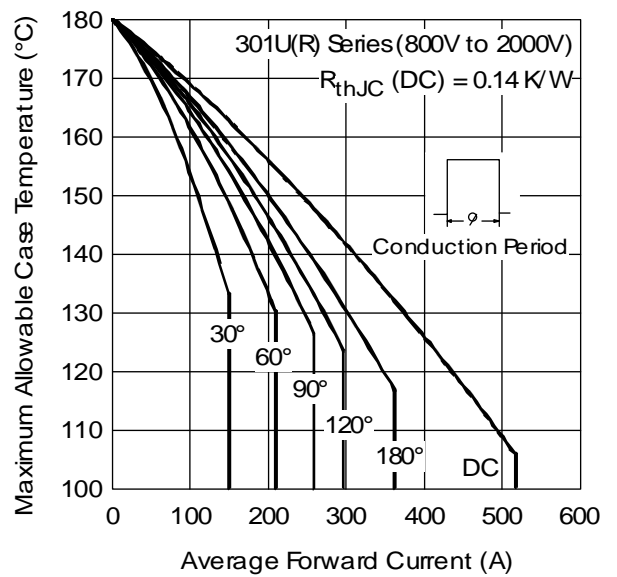

Fig.2 - Current Ratings Characteristics

# 301U(R) Series

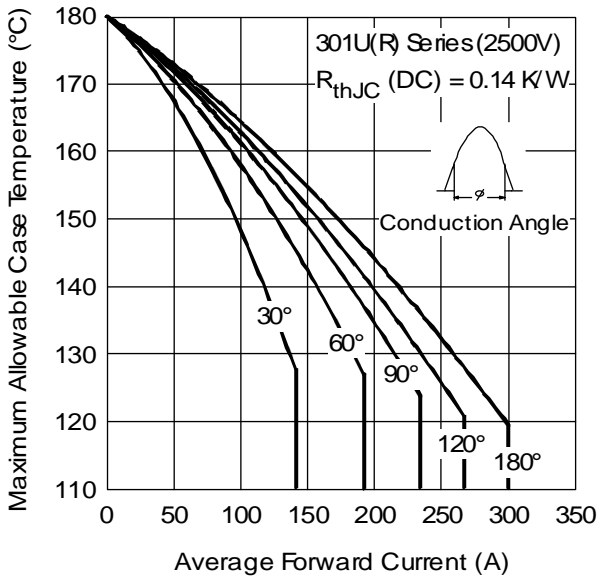

Fig. 3 - Current Ratings Characteristics

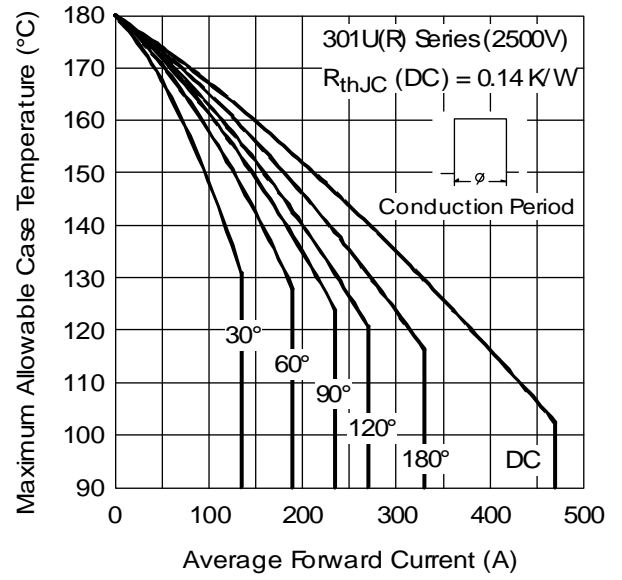

Fig. 4 - Current Ratings Characteristics

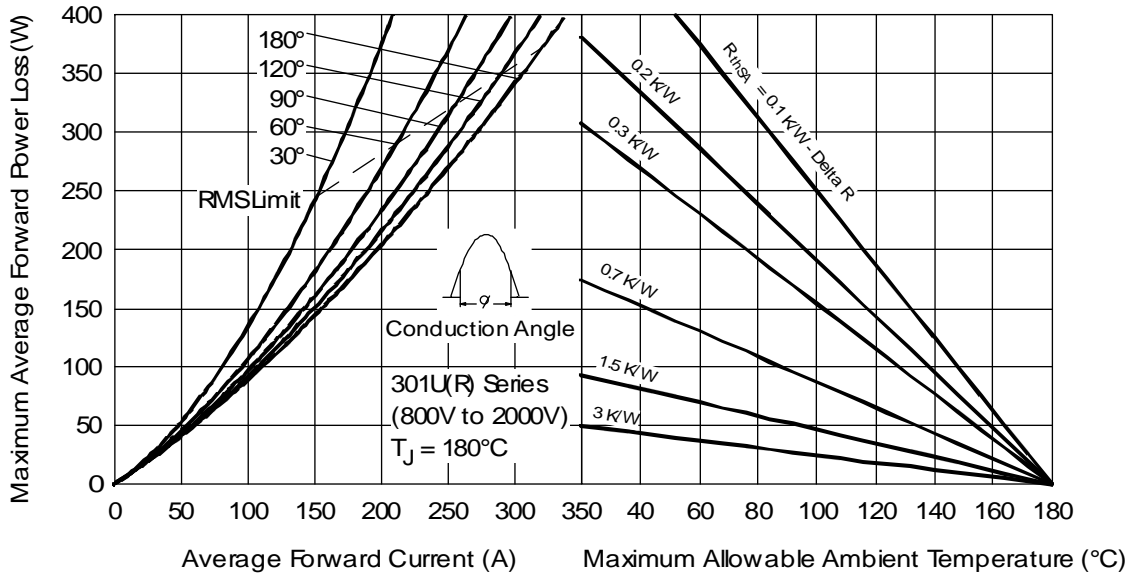

Fig. 5 - Forward Power Loss Characteristics

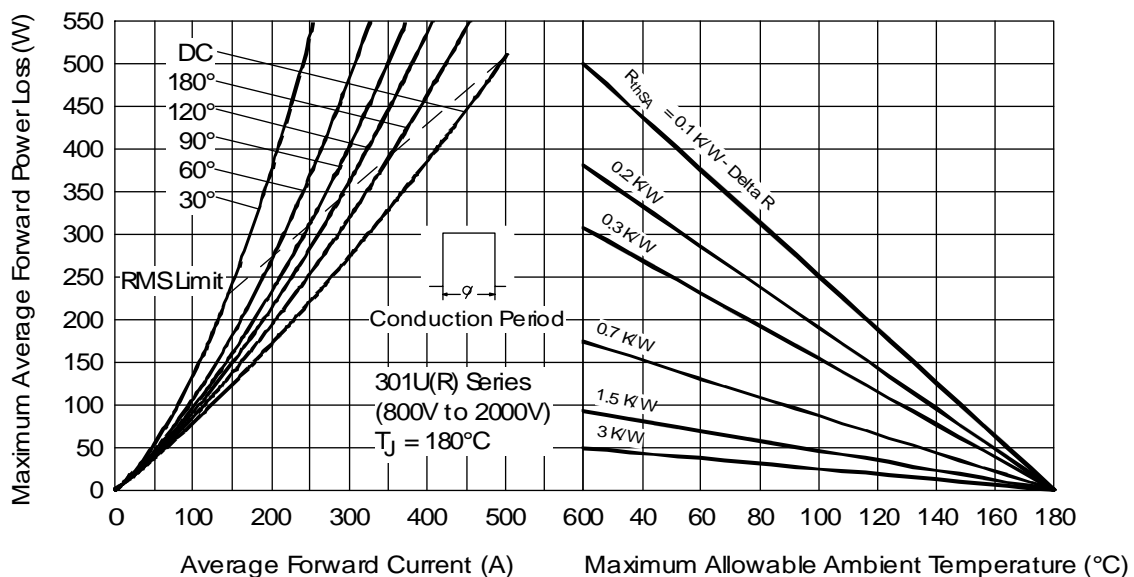

Fig. 6 - Forward Power Loss Characteristics

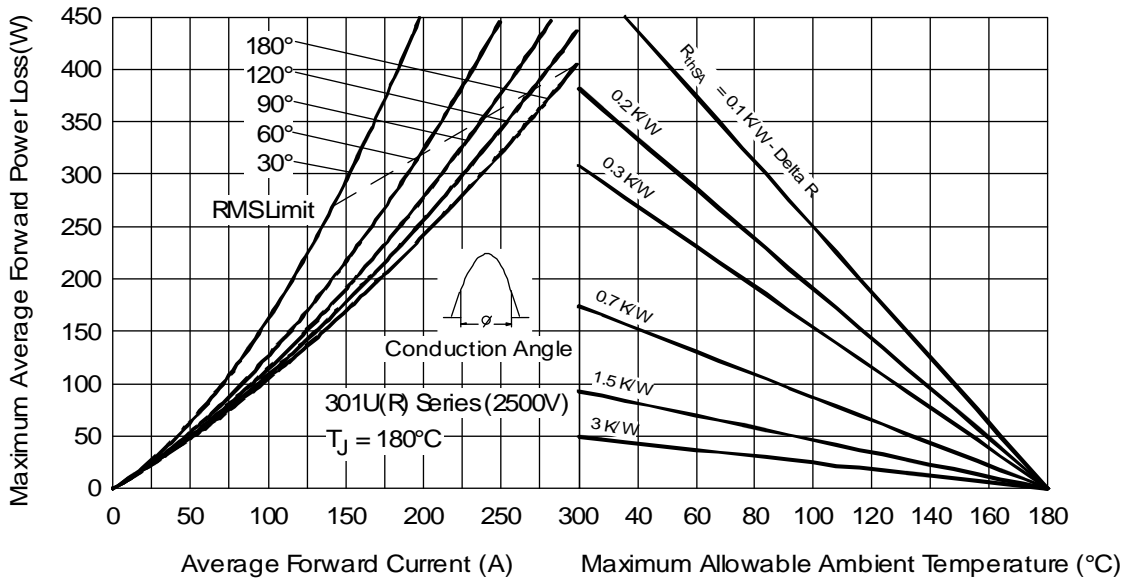

Fig. 7 - Forward Power Loss Characteristics

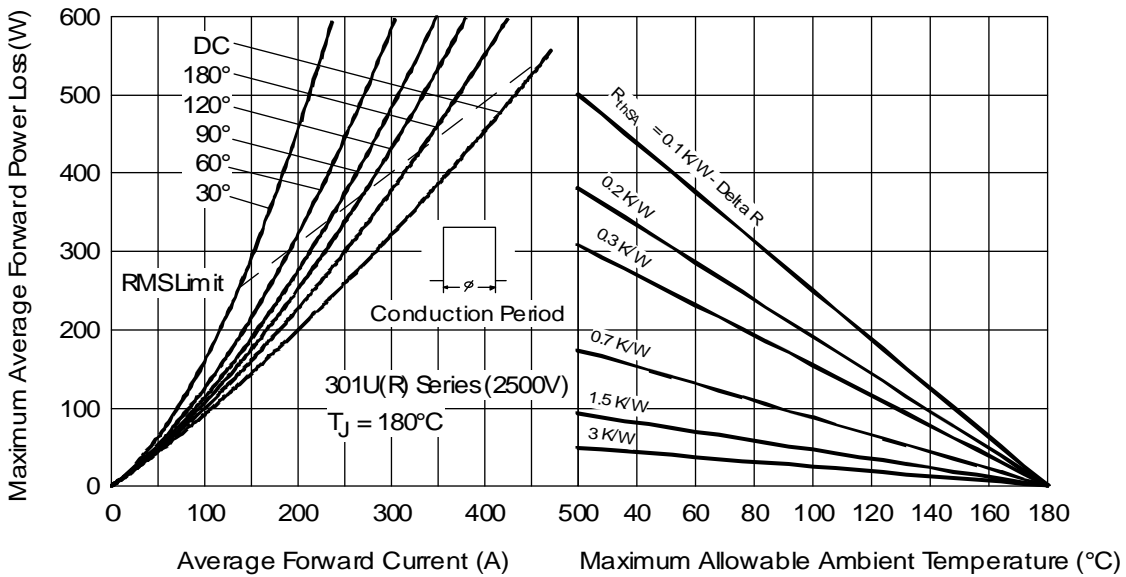
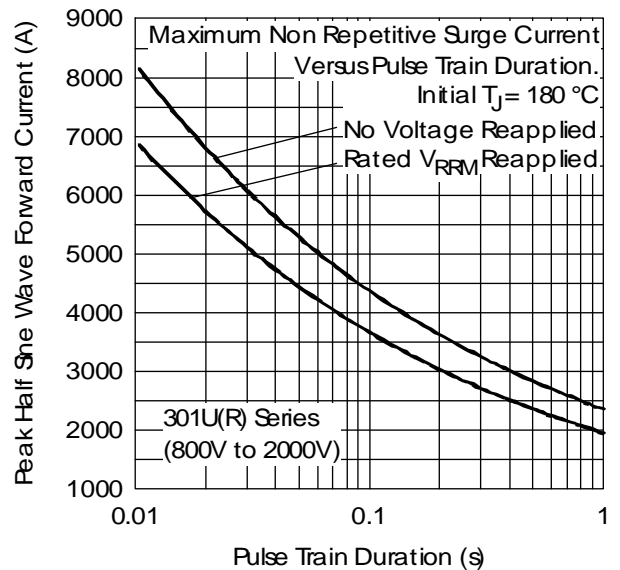
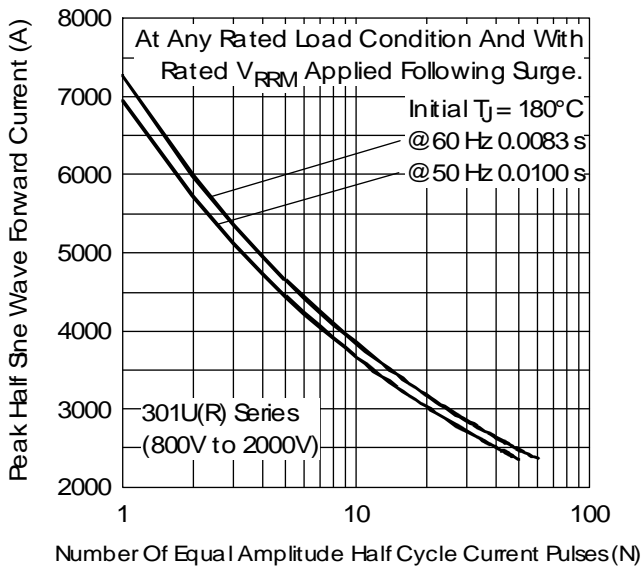

Fig. 8 - Forward Power Loss Characteristics



# 301U(R) Series

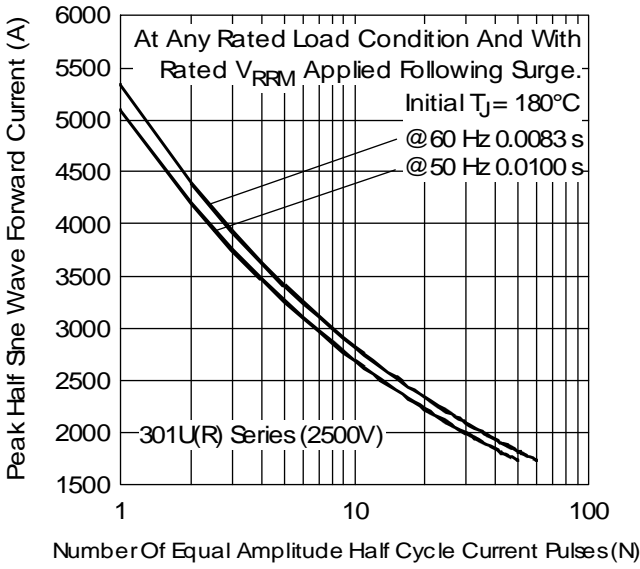

Fig. 11 - Maximum Non-Repetitive Surge Current

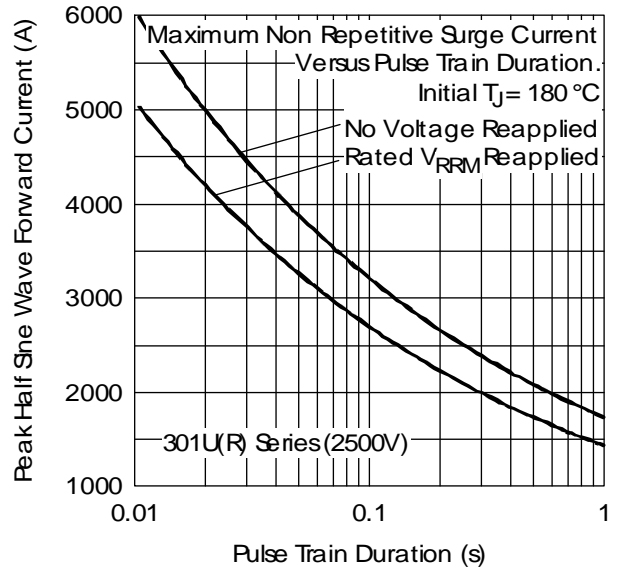

Fig. 12 - Maximum Non-Repetitive Surge Current

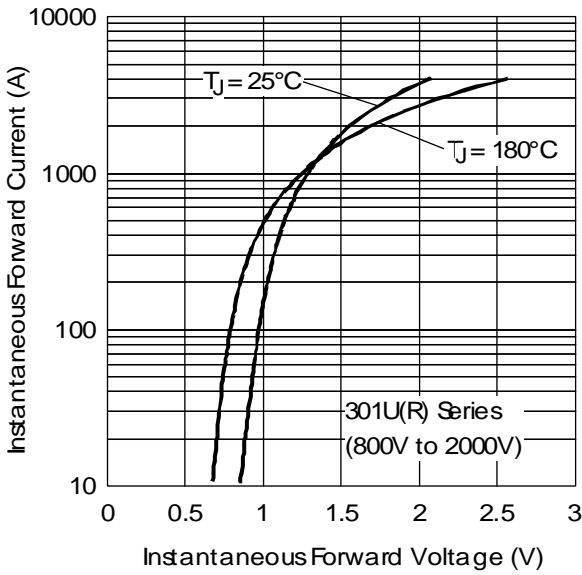

Fig. 13 - Forward Voltage Drop Characteristics

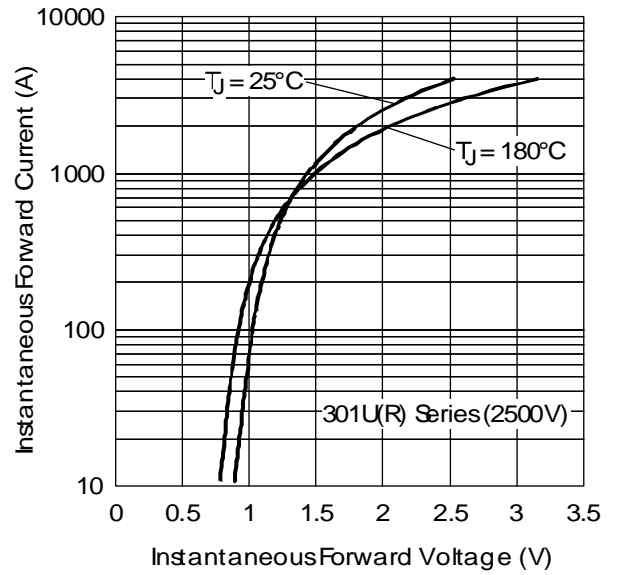

Fig. 14 - Forward Voltage Drop Characteristics

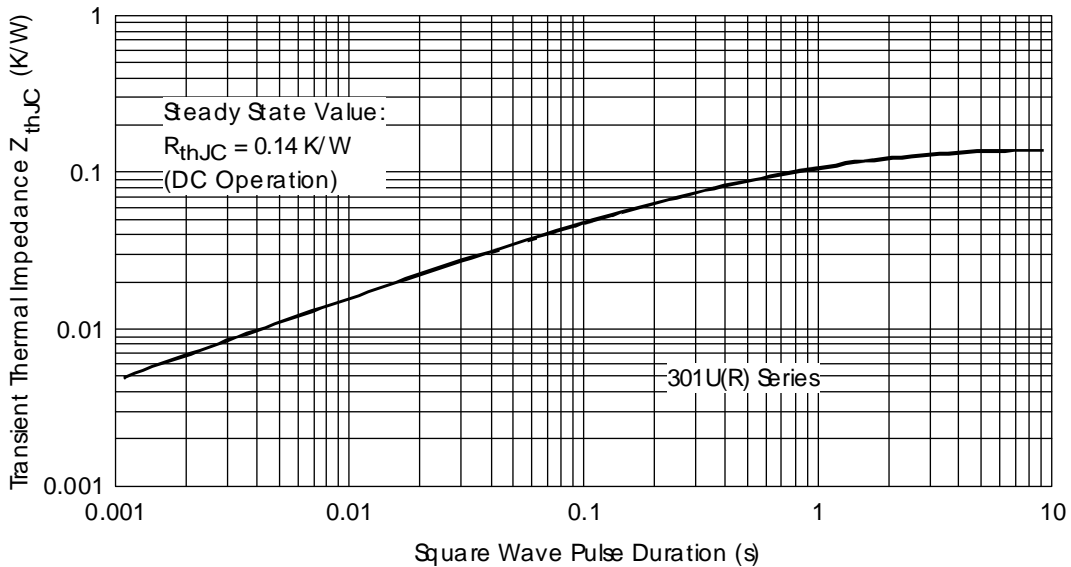

Fig. 15 - Thermal Impedance  $Z_{thJC}$  Characteristic