

INTEGRATED CIRCUITS

DATA SHEET

For a complete data sheet, please also download:

- The IC04 LOCMOS HE4000B Logic Family Specifications HEF, HEC
- The IC04 LOCMOS HE4000B Logic Package Outlines/Information HEF, HEC

HEF4051B

MSI

8-channel analogue multiplexer/demultiplexer

Product specification
File under Integrated Circuits, IC04

January 1995

8-channel analogue multiplexer/demultiplexer

HEF4051B MSI

DESCRIPTION

The HEF4051B is an 8-channel analogue multiplexer/demultiplexer with three address inputs (A_0 to A_2), an active LOW enable input (\bar{E}), eight independent inputs/outputs (Y_0 to Y_7) and a common input/output (Z).

The device contains eight bidirectional analogue switches, each with one side connected to an independent input/output (Y_0 to Y_7)

and the other side connected to a common input/output (Z).

With \bar{E} LOW, one of the eight switches is selected (low impedance ON-state) by A_0 to A_2 . With \bar{E} HIGH, all switches are in the high impedance OFF-state, independent of A_0 to A_2 .

V_{DD} and V_{SS} are the supply voltage connections for the digital control inputs (A_0 to A_2 , and \bar{E}). The V_{DD} to V_{SS} range is 3 to 15 V.

The analogue inputs/outputs (Y_0 to Y_7 , and Z) can swing between V_{DD} as a positive limit and V_{EE} as a negative limit. $V_{DD}-V_{EE}$ may not exceed 15 V.

For operation as a digital multiplexer/demultiplexer, V_{EE} is connected to V_{SS} (typically ground).

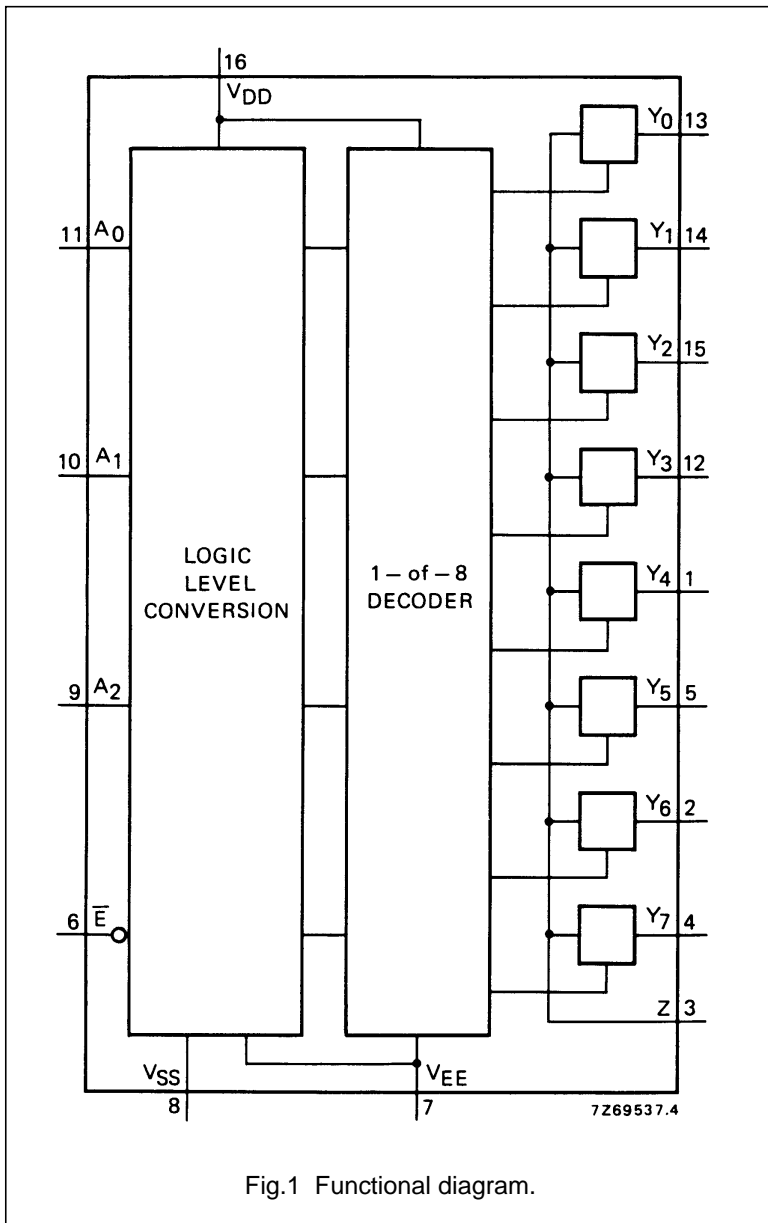

Fig.1 Functional diagram.

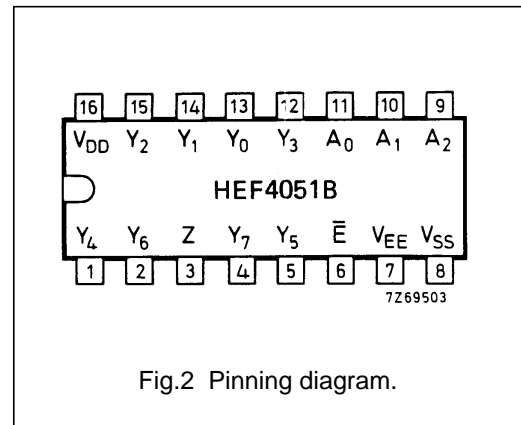

Fig.2 Pinning diagram.

HEF4051BP(N): 16-lead DIL; plastic (SOT38-1)

HEF4051BD(F): 16-lead DIL; ceramic (cerdip) (SOT74)

HEF4051BT(D): 16-lead SO; plastic (SOT109-1)

(): Package Designator North America

PINNING

- Y_0 to Y_7 independent inputs/outputs
- A_0 to A_2 address inputs
- \bar{E} enable input (active LOW)
- Z common input/output

FAMILY DATA, I_{DD} LIMITS category MSI

See Family Specifications.

8-channel analogue multiplexer/demultiplexer

HEF4051B
MSI

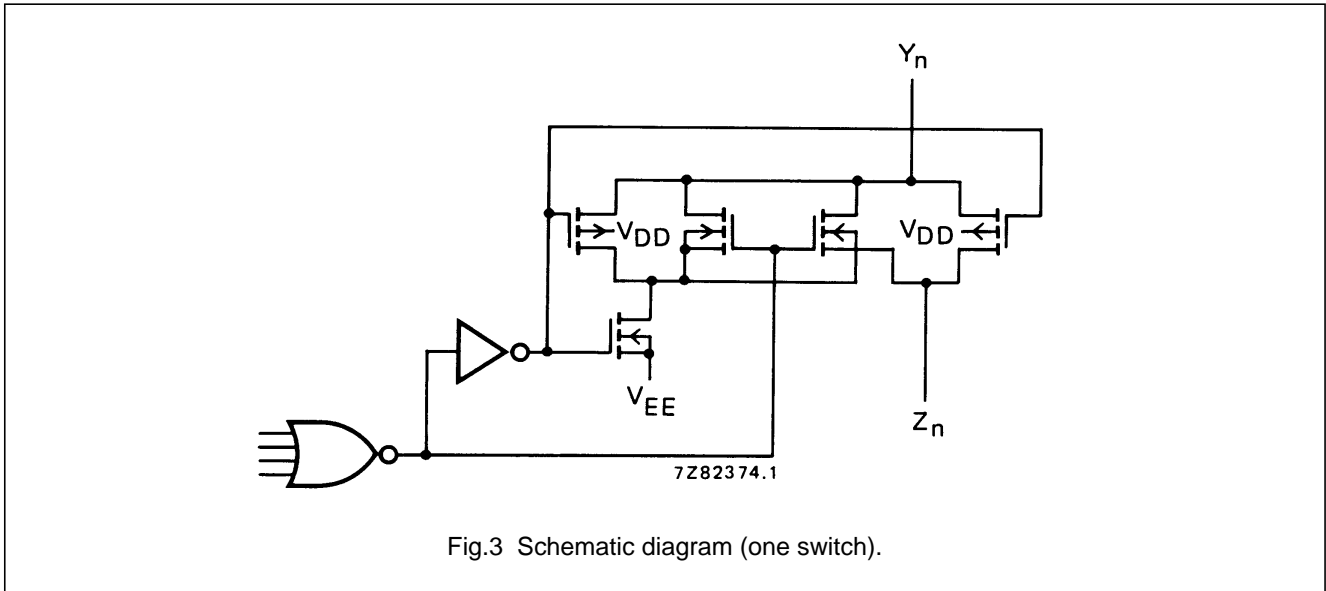

FUNCTION TABLE

INPUTS				CHANNEL ON
\bar{E}	A_2	A_1	A_0	
L	L	L	L	Y_0-Z
L	L	L	H	Y_1-Z
L	L	H	L	Y_2-Z
L	L	H	H	Y_3-Z
L	H	L	L	Y_4-Z
L	H	L	H	Y_5-Z
L	H	H	L	Y_6-Z
L	H	H	H	Y_7-Z
H	X	X	X	none

Notes

- H = HIGH state (the more positive voltage)
L = LOW state (the less positive voltage)
X = state is immaterial

RATINGS

Limiting values in accordance with the Absolute Maximum System (IEC 134)

Supply voltage (with reference to V_{DD}) V_{EE} -18 to +0,5 V

Note

- To avoid drawing V_{DD} current out of terminal Z, when switch current flows into terminals Y, the voltage drop across the bidirectional switch must not exceed 0,4 V. If the switch current flows into terminal Z, no V_{DD} current will flow out of terminals Y, in this case there is no limit for the voltage drop across the switch, but the voltages at Y and Z may not exceed V_{DD} or V_{EE} .

8-channel analogue multiplexer/demultiplexer

HEF4051B
MSI

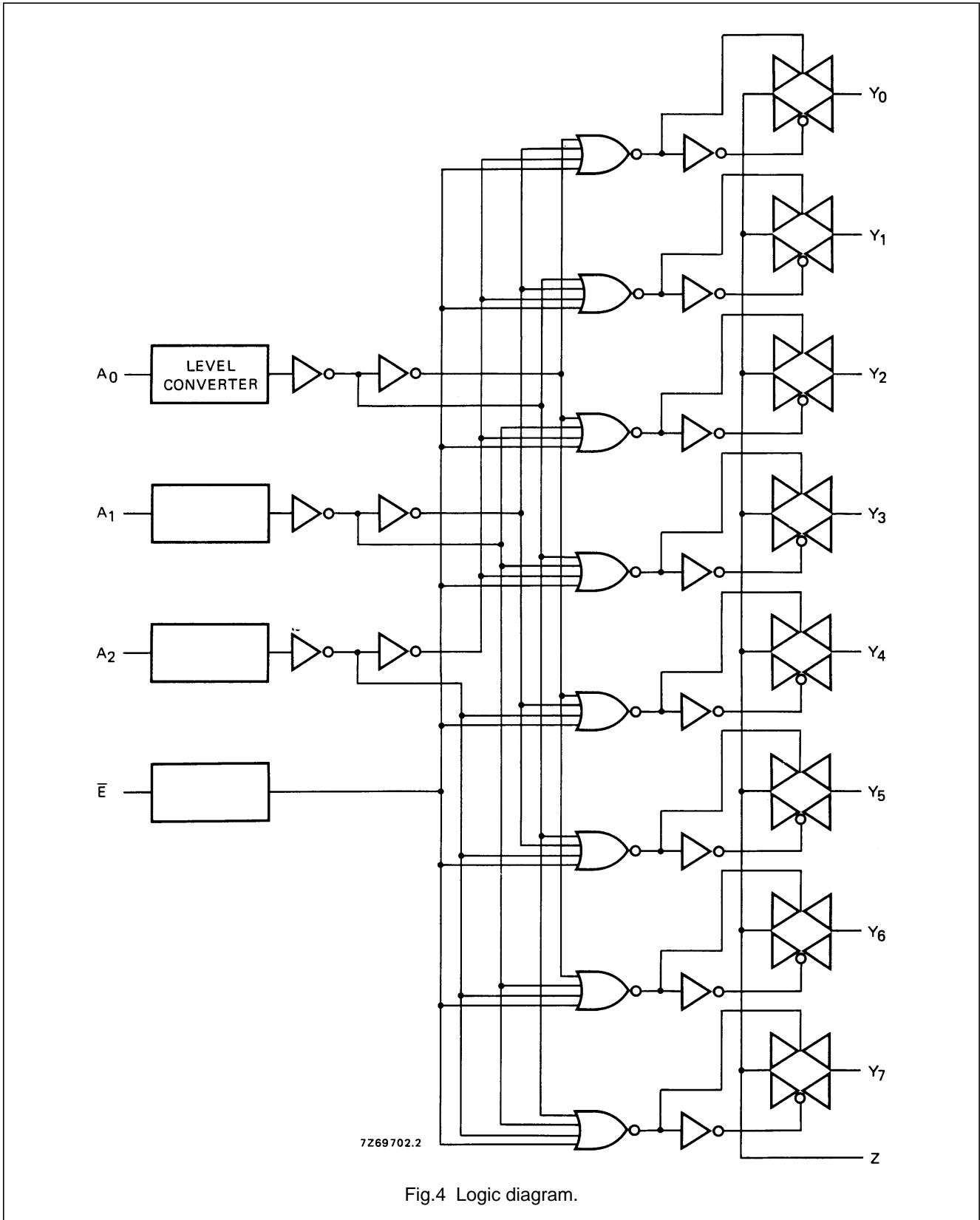

Fig.4 Logic diagram.

8-channel analogue multiplexer/demultiplexer

HEF4051B
MSI

DC CHARACTERISTICS

T_{amb} = 25 °C

	V _{DD} -V _{EE} V	SYMBOL	TYP.	MAX.		CONDITIONS
ON resistance	5	R _{ON}	350	2500	Ω	V _{is} = 0 to V _{DD} -V _{EE} see Fig.6
	10		80	245	Ω	
	15		60	175	Ω	
ON resistance	5	R _{ON}	115	340	Ω	V _{is} = 0 see Fig.6
	10		50	160	Ω	
	15		40	115	Ω	
ON resistance	5	R _{ON}	120	365	Ω	V _{is} = V _{DD} -V _{EE} see Fig.6
	10		65	200	Ω	
	15		50	155	Ω	
'Δ' ON resistance between any two channels	5	ΔR _{ON}	25	-	Ω	V _{is} = 0 to V _{DD} -V _{EE} see Fig.6
	10		10	-	Ω	
	15		5	-	Ω	
OFF-state leakage current, all channels OFF	5	I _{oZZ}	-	-	nA	\bar{E} at V _{DD} V _{SS} = V _{EE}
	10		-	-	nA	
	15		-	1000	nA	
OFF-state leakage current, any channel	5	I _{oZY}	-	-	nA	\bar{E} at V _{SS} V _{SS} = V _{EE}
	10		-	-	nA	
	15		-	200	nA	

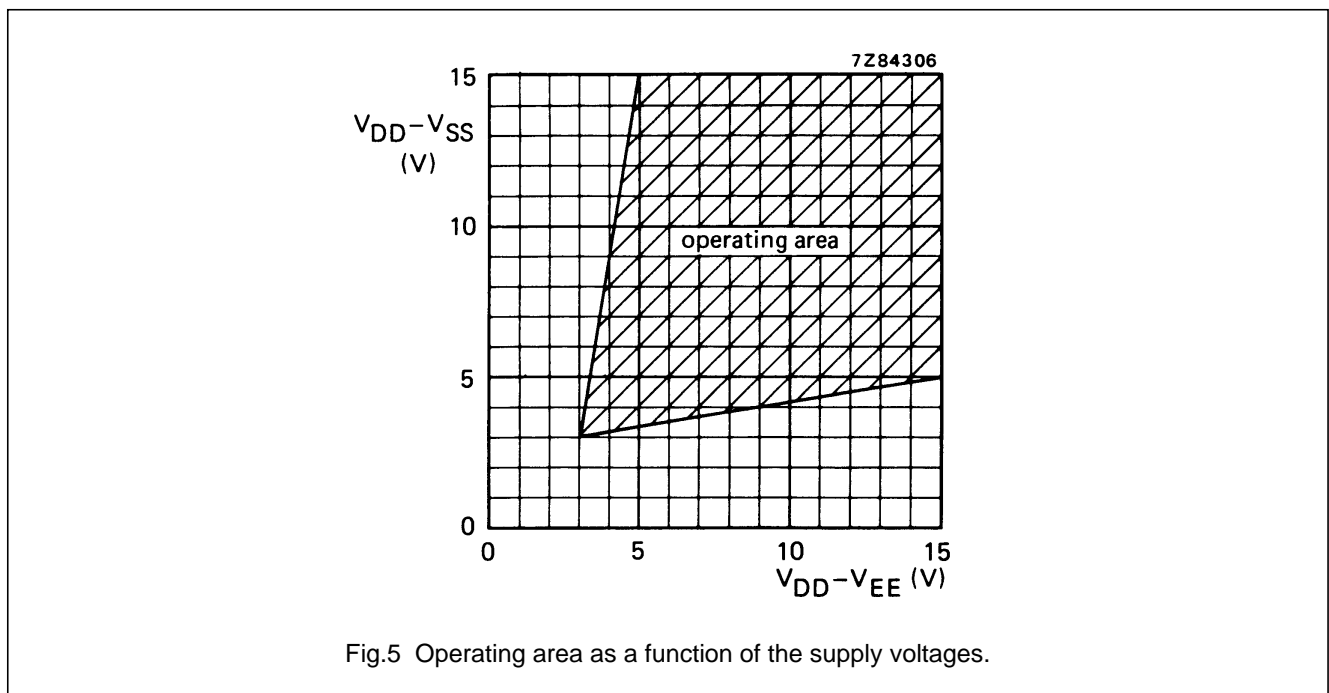

Fig.5 Operating area as a function of the supply voltages.

8-channel analogue multiplexer/demultiplexer

HEF4051B
MSI

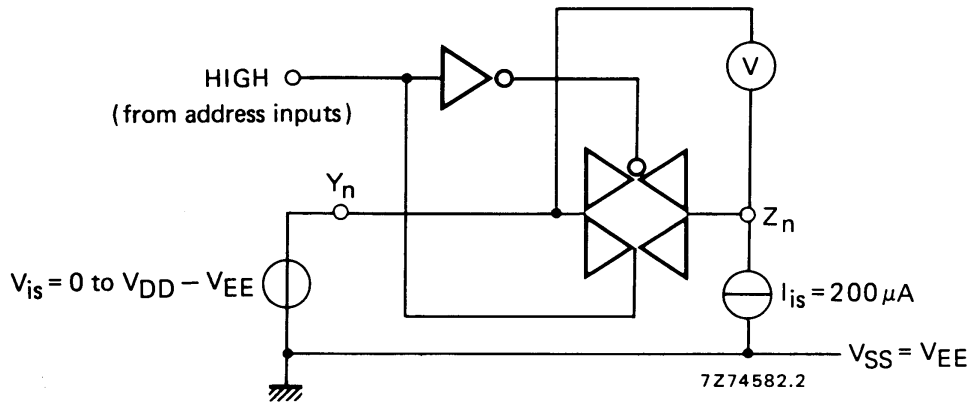
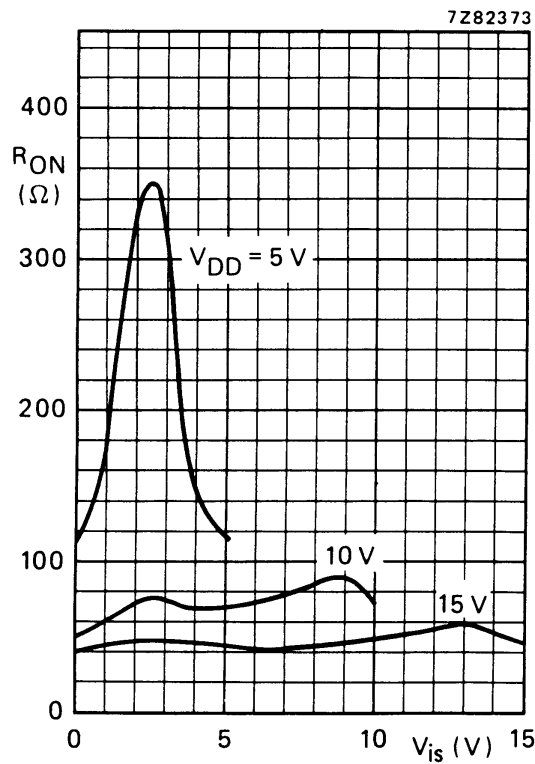

Fig.6 Test set-up for measuring R_{ON} .



$I_{is} = 200 \mu A$
 $V_{SS} = V_{EE} = 0 V$

Fig.7 Typical R_{ON} as a function of input voltage.

8-channel analogue multiplexer/demultiplexer

HEF4051B
MSI**AC CHARACTERISTICS** $V_{EE} = V_{SS} = 0 \text{ V}$; $T_{amb} = 25 \text{ }^\circ\text{C}$; input transition times $\leq 20 \text{ ns}$

	V_{DD} V	TYPICAL FORMULA FOR P (μW)	
Dynamic power dissipation per package (P)	5	$1\,000 f_i + \sum(f_o C_L) \times V_{DD}^2$	where f_i = input freq. (MHz) f_o = output freq. (MHz) C_L = load capacitance (pF) $\sum(f_o C_L)$ = sum of outputs V_{DD} = supply voltage (V)
	10	$5\,500 f_i + \sum(f_o C_L) \times V_{DD}^2$	
	15	$15\,000 f_i + \sum(f_o C_L) \times V_{DD}^2$	

AC CHARACTERISTICS $V_{EE} = V_{SS} = 0 \text{ V}$; $T_{amb} = 25 \text{ }^\circ\text{C}$; input transition times $\leq 20 \text{ ns}$

	V_{DD} V	SYMBOL	TYP.	MAX.			
Propagation delays $V_{is} \rightarrow V_{os}$ HIGH to LOW	5	t_{PHL}	15	30	ns	note 1	
	10		5	10	ns		
	15		5	10	ns		
	LOW to HIGH	5	t_{PLH}	15	30	ns	note 1
		10		5	10	ns	
		15		5	10	ns	
$A_n \rightarrow V_{os}$ HIGH to LOW	5	t_{PHL}	150	300	ns	note 2	
	10		60	120	ns		
	15		45	90	ns		
	LOW to HIGH	5	t_{PLH}	150	300	ns	note 2
		10		65	130	ns	
		15		45	90	ns	
Output disable times $\bar{E} \rightarrow V_{os}$ HIGH	5	t_{PHZ}	120	240	ns	note 3	
	10		90	180	ns		
	15		85	170	ns		
	LOW	5	t_{PLZ}	145	290	ns	note 3
		10		120	240	ns	
		15		115	230	ns	
Output enable times $\bar{E} \rightarrow V_{os}$ HIGH	5	t_{PZH}	140	280	ns	note 3	
	10		55	110	ns		
	15		40	80	ns		
	LOW	5	t_{PZL}	140	280	ns	note 3
		10		55	110	ns	
		15		40	80	ns	

8-channel analogue multiplexer/demultiplexer

HEF4051B
MSI

	V _{DD} V	SYMBOL	TYP.	MAX.	
Distortion, sine-wave response	5		0,25	%	note 4
	10		0,04	%	
	15		0,04	%	
Crosstalk between any two channels	5		–	MHz	note 5
	10		1	MHz	
	15		–	MHz	
Crosstalk; enable or address input to output	5		–	mV	note 6
	10		50	mV	
	15		–	mV	
OFF-state feed-through	5		–	MHz	note 7
	10		1	MHz	
	15		–	MHz	
ON-state frequency response	5		13	MHz	note 8
	10		40	MHz	
	15		70	MHz	

Notes

V_{is} is the input voltage at a Y or Z terminal, whichever is assigned as input.

V_{os} is the output voltage at a Y or Z terminal, whichever is assigned as output.

- R_L = 10 kΩ to V_{EE}; C_L = 50 pF to V_{EE}; $\bar{E} = V_{SS}$; V_{is} = V_{DD} (square-wave); see Fig.8.
- R_L = 10 kΩ; C_L = 50 pF to V_{EE}; $\bar{E} = V_{SS}$; A_n = V_{DD} (square-wave); V_{is} = V_{DD} and R_L to V_{EE} for t_{PLH}; V_{is} = V_{EE} and R_L to V_{DD} for t_{PHL}; see Fig.8.
- R_L = 10 kΩ; C_L = 50 pF to V_{EE}; $\bar{E} = V_{DD}$ (square-wave);
V_{is} = V_{DD} and R_L to V_{EE} for t_{PHZ} and t_{PZH};
V_{is} = V_{EE} and R_L to V_{DD} for t_{PLZ} and t_{PZL}; see Fig.8.
- R_L = 10 kΩ; C_L = 15 pF; channel ON; V_{is} = 1/2 V_{DD (p-p)} (sine-wave, symmetrical about 1/2 V_{DD});
f_{is} = 1 kHz; see Fig.9.
- R_L = 1 kΩ; V_{is} = 1/2 V_{DD (p-p)} (sine-wave, symmetrical about 1/2 V_{DD});
 $20 \log \frac{V_{os}}{V_{is}} = -50 \text{ dB}$; see Fig. 10.
- R_L = 10 kΩ to V_{EE}; C_L = 15 pF to V_{EE}; \bar{E} or A_n = V_{DD} (square-wave); crosstalk is |V_{os}| (peak value); see Fig.8.
- R_L = 1 kΩ; C_L = 5 pF; channel OFF; V_{is} = 1/2 V_{DD (p-p)} (sine-wave, symmetrical about 1/2 V_{DD});
 $20 \log \frac{V_{os}}{V_{is}} = -50 \text{ dB}$; see Fig. 9.
- R_L = 1 kΩ; C_L = 5 pF; channel ON; V_{is} = 1/2 V_{DD (p-p)} (sine-wave, symmetrical about 1/2 V_{DD});
 $20 \log \frac{V_{os}}{V_{is}} = -3 \text{ dB}$; see Fig. 9.

8-channel analogue multiplexer/demultiplexer

HEF4051B
MSI

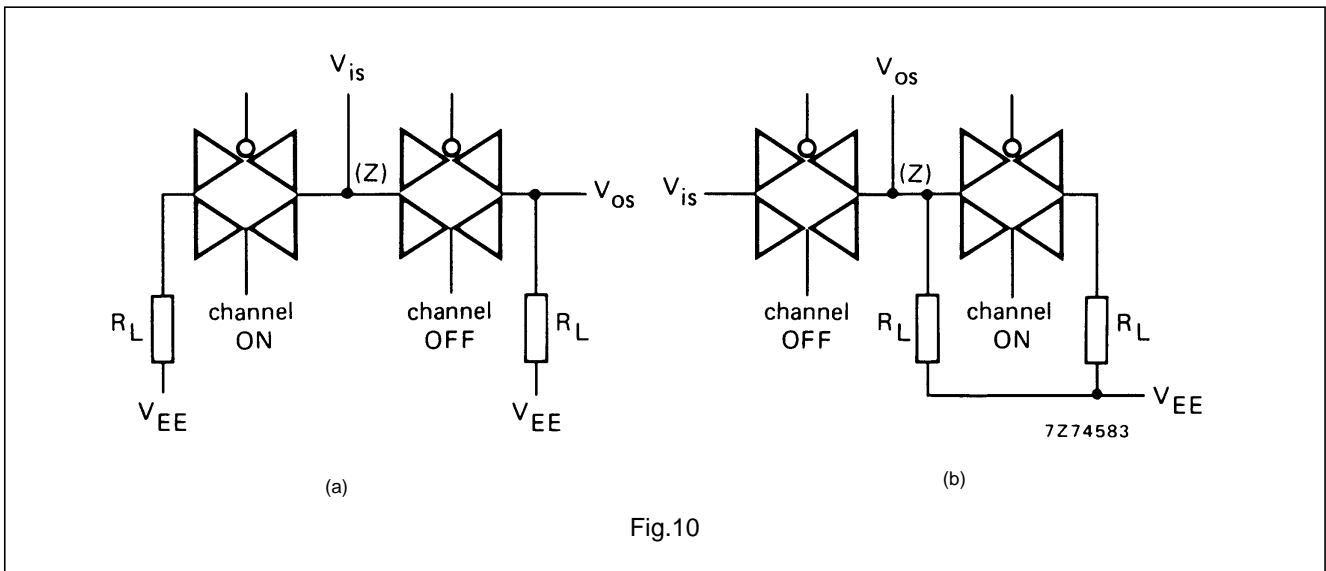
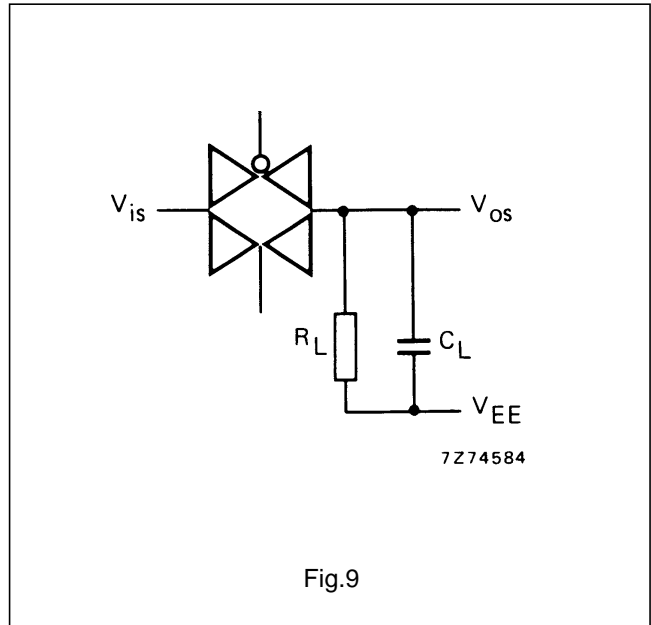
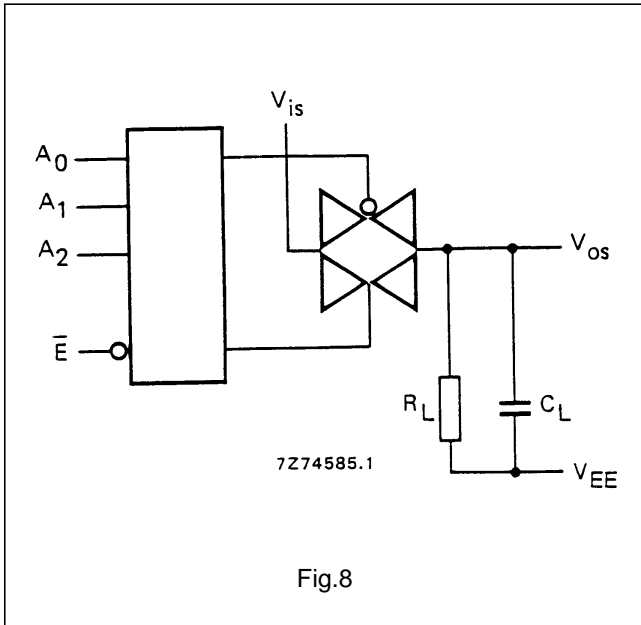

APPLICATION INFORMATION

Some examples of applications for the HEF4051B are:

- Analogue multiplexing and demultiplexing.
- Digital multiplexing and demultiplexing.
- Signal gating.

NOTE

If break before make is needed, then it is necessary to use the enable input.