

NCP1800

Single-Cell Lithium Ion Battery Charge Controller

The NCP1800 is a constant current, constant voltage (CCCV) lithium ion battery charge controller. The external sense resistor sets the full charging current, and the termination current is 10% of the full charge current (0.1 C). The voltage is regulated at $\pm 1\%$ during the final charge stage. There is virtually zero drain on the battery when the input power is removed.

Features

- Integrated Voltage and Programmable Current Regulation
- Integrated Cell Conditioning for Deeply Discharged Cell
- Integrated End of Charge Detection
- Better than 1% Voltage Regulation
- Charger Status Output for LED or Host Processor Interface
- Charge Interrupt Input
- Safety Shutoff for Removal of Battery
- Adjustable Charge Current Limit
- Input Over and Under Voltage Lockout
- Micro8 Package

Applications

- Cellular Phones, PDAs
- Handheld Equipment
- Battery Operated Portable Devices



ON Semiconductor®

<http://onsemi.com>

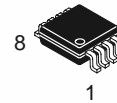

Micro8™
CASE 846A
DM SUFFIX

PIN CONNECTIONS AND MARKING DIAGRAM

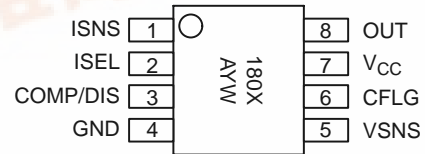

X = A for 41 Device
B for 42 Device

A = Assembly Location
L = Wafer Lot
Y = Year
W = Work Week

ORDERING INFORMATION

| Device | Package | Shipping |
|---------------|---------|-----------------|
| NCP1800DM41R2 | Micro8 | 4000 Units/Reel |
| NCP1800DM42R2 | Micro8 | 4000 Units/Reel |

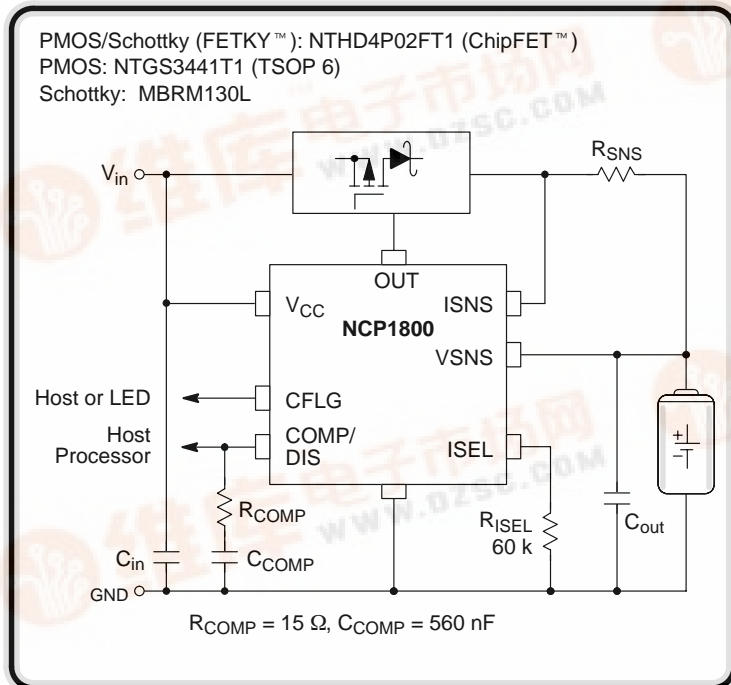

Figure 1. Typical Application



NCP1800

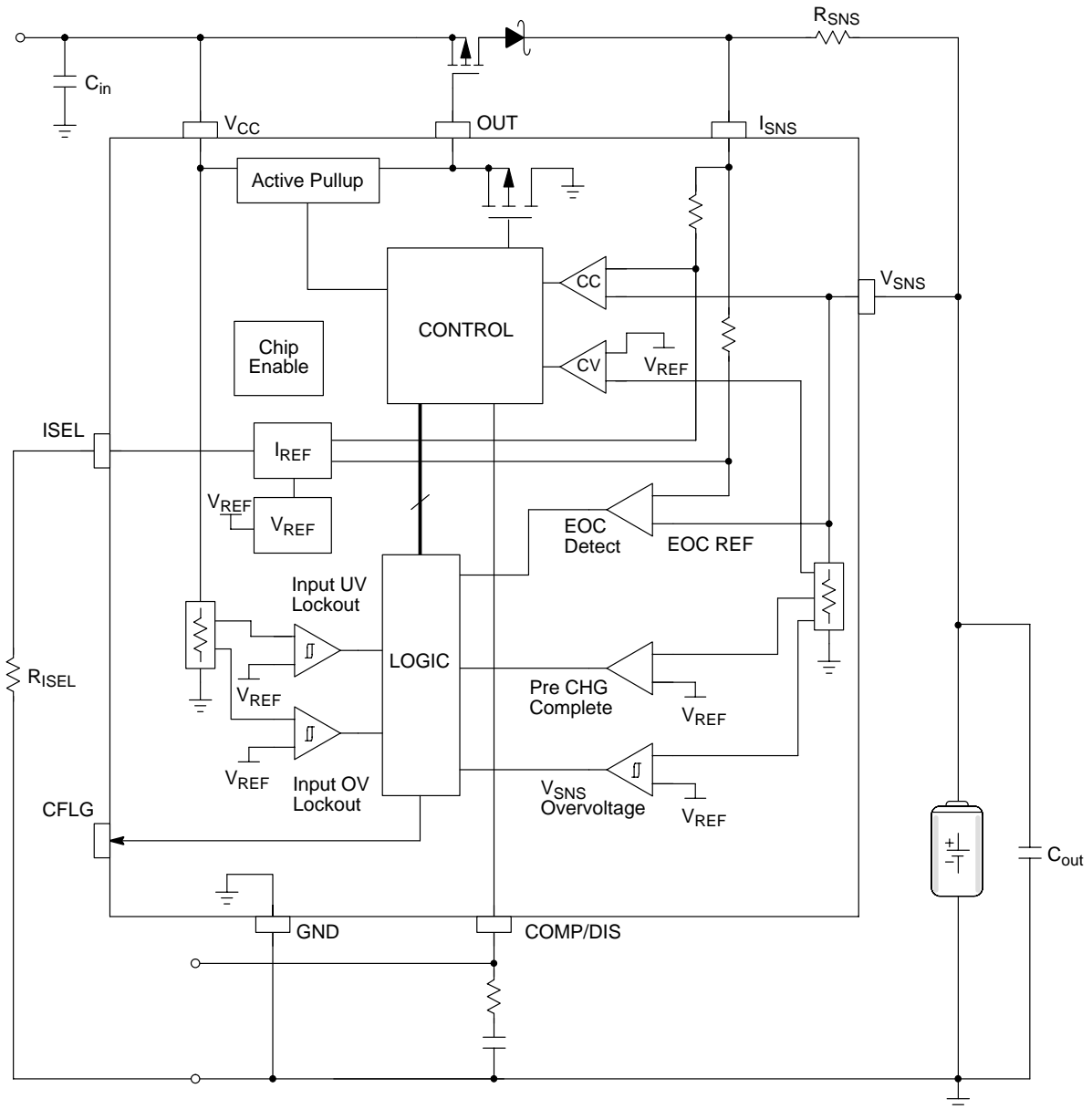

Figure 2. NCP1800 Internal Block Diagram

PIN FUNCTION DESCRIPTIONS

| Pin | Symbol | Description |
|-----|-----------|---|
| 1 | I_{SNS} | This is one of the inputs to the current regulator and the end-of-charge comparator. |
| 2 | ISEL | A resistor from this pin to ground pin sets the full charging current regulation level. |
| 3 | COMP/DIS | This is a multifunctional pin that is used for compensation and can be used to interrupt charge with an open drain/collector output from a microcontroller. When this pin is pulled to ground, the charge current is interrupted. |
| 4 | GND | This is the ground pin of the IC. |
| 5 | V_{SNS} | This is an input that is used to sense battery voltage and is the other input to the current regulator. It also serves as the input to the battery overvoltage comparator. |
| 6 | CFLG | An open drain output that indicates the battery charging status. |
| 7 | V_{CC} | This is a multifunctional pin that powers the device and senses for over and undervoltage conditions. |
| 8 | OUT | This is a current source driver for the pass transistor. |

NCP1800

MAXIMUM RATINGS

| Rating | Symbol | Value | Unit |
|---|-----------------|---|------|
| Supply Voltage | V_{CC} | 16 | V |
| Voltage Range for: VSNS Input ISNS Input COMP/DIS Input ISEL Input CFLG Output Out Output | - | -0.3 to 6.0 -0.3 to 6.0 -0.3 to 6.0 -0.3 to 6.0 -0.3 to 6.0 -0.3 to V_{CC} | V |
| OUT Sink Current | I_o | 20 | mA |
| Thermal Resistance, Junction to Air | $R_{\theta JA}$ | 240 | °C/W |
| Operating Ambient Temperature | T_A | -20 to +85 | °C |
| Operating Junction Temperature | T_J | -20 to +150 | °C |
| Storage Temperature | T_{stg} | -55 to +150 | °C |

ATTRIBUTES

| Characteristic | Value |
|--|-------------------|
| ESD Protection Human Body Model (HBM) per JEDEC standard JESD22-A114 Machine Model (MM) per JEDEC standard JESD22-A114 | ≤ 2 kV ≤ 200 V |
| Moisture Sensitivity, Indefinite Time Out of Drypack (Note 1) | Level 1 |
| Transistor Count | 1015 |
| Latch-up Current Maximum Rating per JEDEC standard JESD78 | ≤ 150 mA |

1. For additional information, see Application Note AND8003/D.

ELECTRICAL CHARACTERISTICS ($T_A = 25^\circ\text{C}$ for typical values, $-20^\circ\text{C} < T_A < 85^\circ\text{C}$ for min/max values, unless otherwise noted.)

| Characteristic | Symbol | Min | Typ | Max | Unit |
|--|--------------|----------------|-------------|----------------|------|
| Input Supply Voltage (Note 2) | V_{CC} | 2.5 | - | 16 | V |
| Input Supply Current | I_{CC} | - | 140 | 250 | μA |
| Regulated Output Voltage | V_{REG} | 4.059 4.158 | 4.1 4.2 | 4.141 4.242 | V |
| Full-Charge Current Reference Voltage $V_{CC} = 6.0\text{ V}$, $3.0\text{ V} < V_{SNS} < 4.2\text{ V}$, $R_{ISEL} = 60\text{ K}\Omega$, $T_A = 25^\circ\text{C}$ | V_{FCHG} | 210 | 240 | 270 | mV |
| Full-Charge Current Reference Voltage Temperature Coefficient $V_{CC} = 6.0\text{ V}$, $3.0\text{ V} < V_{SNS} < 4.2\text{ V}$, $R_{ISEL} = 60\text{ K}\Omega$ | TCV_{FCHG} | - | -0.163 | - | %/°C |
| Pre-Charge Current Reference Voltage $V_{CC} = 6.0\text{ V}$, $V_{SNS} < 3.0\text{ V}$, $R_{ISEL} = 60\text{ K}\Omega$, $T_A = 25^\circ\text{C}$ | V_{PCHG} | 13.2 | 24 | 34.8 | mV |
| Pre-Charge Current Reference Voltage Temperature Coefficient $V_{CC} = 6.0\text{ V}$, $V_{SNS} < 3.0\text{ V}$, $R_{ISEL} = 60\text{ K}\Omega$ | TCV_{PCHG} | - | -0.180 | - | %/°C |
| Pre-Charge Threshold Voltage | V_{PCTH} | 2.78 2.85 | 2.93 3.0 | 3.08 3.15 | V |
| V_{CC} Under Voltage Lockout Voltage | V_{UVLO} | 3.43 | 3.56 | 3.69 | V |
| Hysteresis of V_{CC} Under Voltage Lockout (V_{UVLO}), $T_A = 25^\circ\text{C}$ | - | 90 | 150 | 195 | mV |
| Hysteresis of V_{CC} Under Voltage Lockout Voltage (V_{UVLO}) Temperature Coefficient | - | - | 0.261 | - | %/°C |
| End-of-Charge Voltage Reference $V_{CC} = 6.0\text{ V}$, $V_{SNS} > 4.2\text{ V}$, $R_{ISEL} = 60\text{ K}\Omega$, $T_A = 25^\circ\text{C}$ | V_{EOC} | 20 | 24 | 28 | mV |
| End-of-Charge Voltage Reference Temperature Coefficient $V_{CC} = 6.0\text{ V}$, $V_{SNS} > 4.2\text{ V}$, $R_{ISEL} = 60\text{ K}\Omega$ | TCV_{EOC} | - | -0.160 | - | %/°C |

2. See the "External Adaptor Power Supply Voltage Selection" section of the application note to determine the minimum voltage of the charger power supplies.

NCP1800

ELECTRICAL CHARACTERISTICS (continued)

($T_A = 25^\circ\text{C}$ for typical values, $-20^\circ\text{C} < T_A < 85^\circ\text{C}$ for min/max values, unless otherwise noted.)

| Characteristic | Symbol | Min | Typ | Max | Unit |
|---|--------------------|------------|------------|------------|---------------------|
| Charge Disable Threshold Voltage ($I_{\text{COMP}} = 100 \mu\text{A min.}$) | V_{CDIS} | - | - | 0.08 | V |
| V_{CC} Over Voltage Lockout | V_{OVLO} | 6.95 | 7.20 | 7.45 | V |
| Hysteresis of V_{CC} Over Voltage Lockout (V_{OVLO}), $T_A = 25^\circ\text{C}$ | - | 90 | 150 | 180 | mV |
| Hysteresis of V_{CC} Over Voltage Lockout (V_{OVLO}) Temperature Coefficient | - | - | 0.39 | - | %/ $^\circ\text{C}$ |
| V_{SNS} Over Voltage Lockout NCP1800DM41 NCP1800DM42 | V_{SOVLO} | 4.3 4.4 | 4.4 4.5 | 4.5 4.6 | V |
| Hysteresis of V_{SNS} Over Voltage Lockout (V_{SOVLO}), $T_A = 25^\circ\text{C}$ | - | 40 | 70 | 100 | mV |
| Hysteresis of V_{SNS} Over Voltage Lockout (V_{SOVLO}) Temperature Coefficient $T_A = 25^\circ\text{C}$ | - | - | 0.52 | - | %/ $^\circ\text{C}$ |
| Full Charge Current Range with $R_{\text{SNS}} = 0.4 \Omega$ | I_{REG1} | 600 | - | 1000 | mA |
| Full Charge Current Range with $R_{\text{SNS}} = 0.8 \Omega$ | I_{REG2} | 300 | - | 600 | mA |
| Battery Drain Current ($V_{\text{SNS}} + I_{\text{SNS}}$) $V_{\text{CC}} = \text{Ground}$, $V_{\text{SNS}} = 4.2 \text{ V}$ | I_{BDRN} | - | - | 0.5 | μA |
| CFLG Pin Output Low Voltage (CFLG = LOW, $I_{\text{CFLG}} = 5.0 \text{ mA}$) | V_{CFLGL} | - | - | 0.35 | V |
| CFLG Pin Leakage Current (CFLG = HIGH) | I_{CFLGH} | - | - | 0.1 | μA |

NCP1800

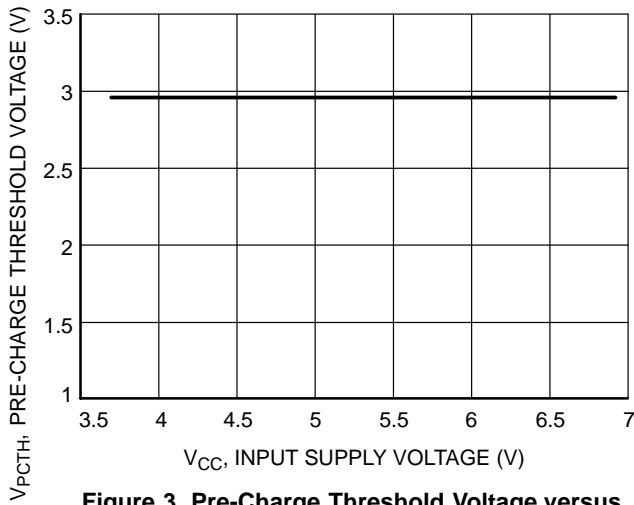

Figure 3. Pre-Charge Threshold Voltage versus Input Supply Voltage

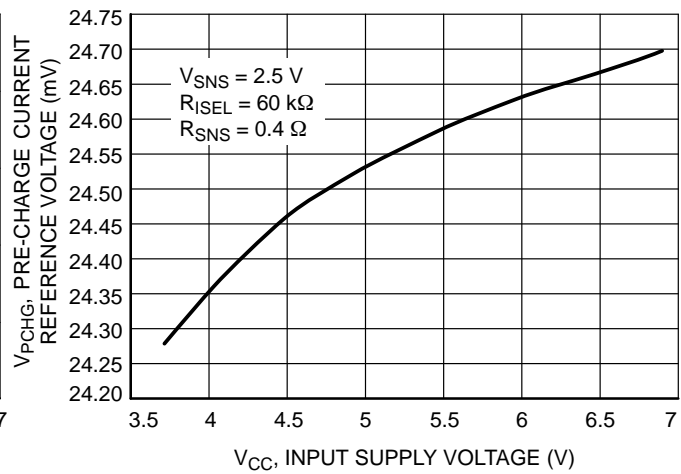

Figure 4. Pre-Charge Current Reference Voltage versus Input Supply Voltage

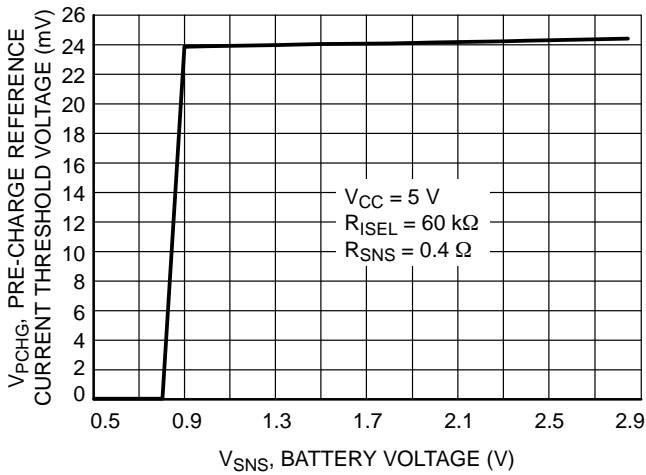

Figure 5. Pre-Charge Current Reference Voltage versus Battery Voltage

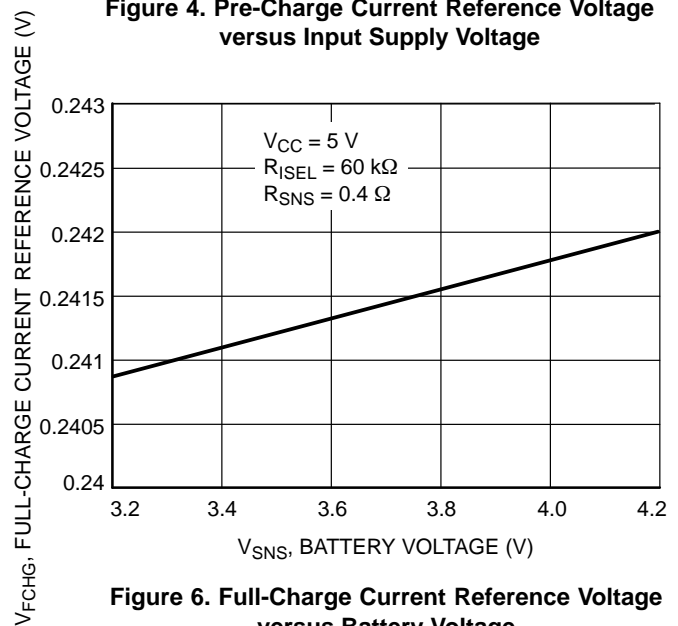

Figure 6. Full-Charge Current Reference Voltage versus Battery Voltage

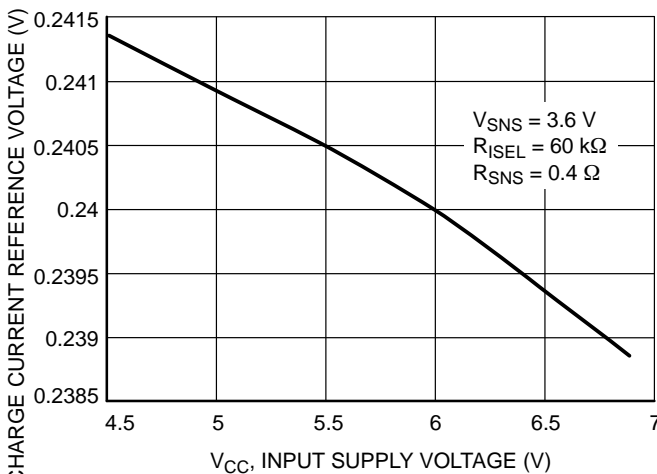

Figure 7. Full-Charge Current Reference Voltage versus Input Supply Voltage

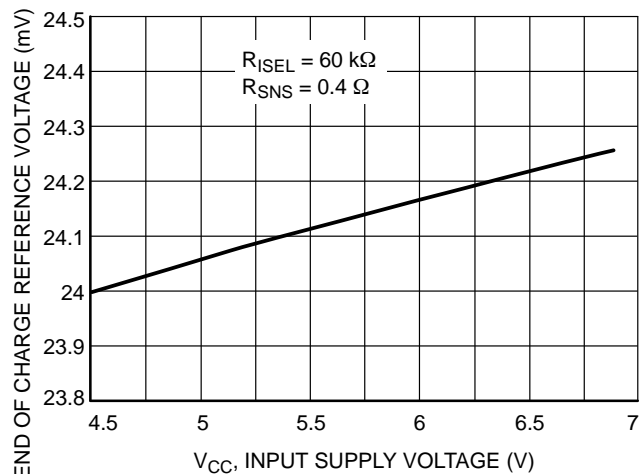

Figure 8. End of Charge Reference Voltage versus Input Supply Voltage

NCP1800

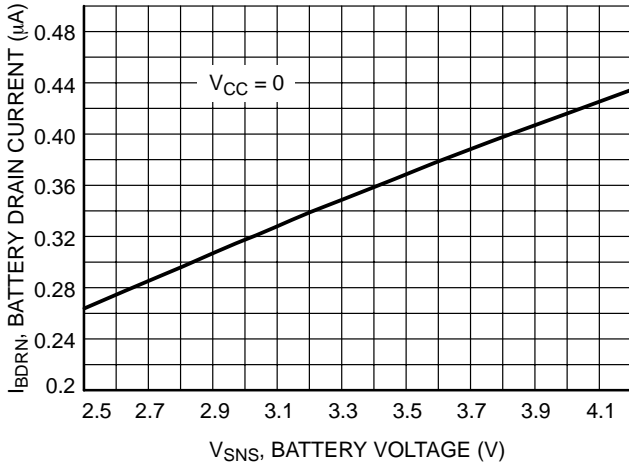

Figure 9. Battery Drain Current versus Battery Voltage

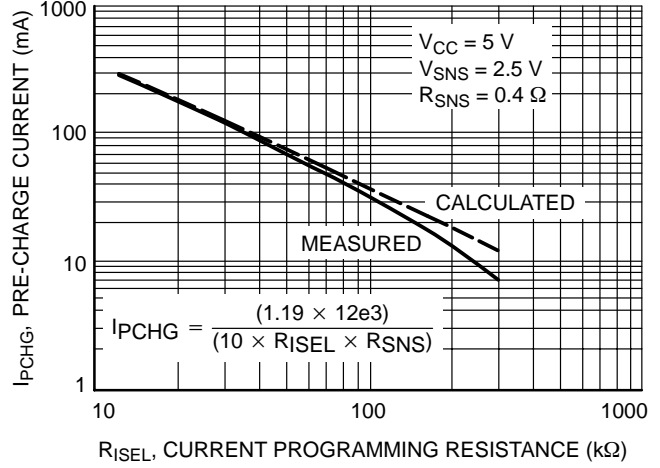

Figure 10. Pre-Charge Current versus Current Programming Resistor

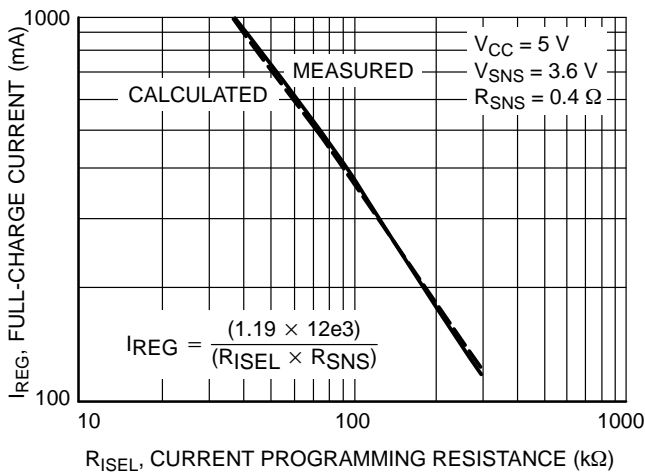

Figure 11. Full-Charge Current versus Current Programming Resistor

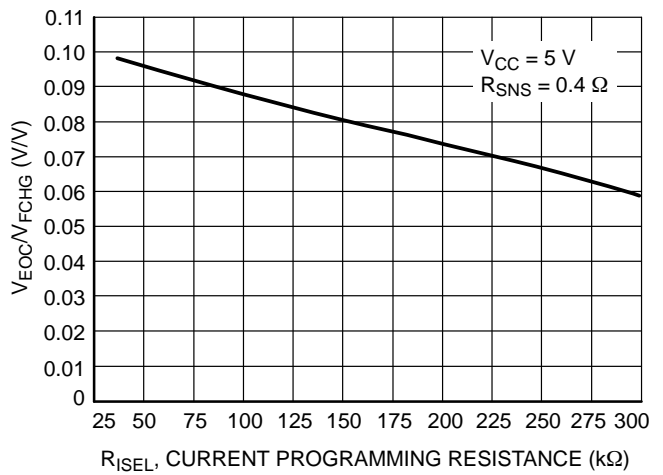

Figure 12. V_{EOC}/V_{FCHG} versus Current Programming Resistor

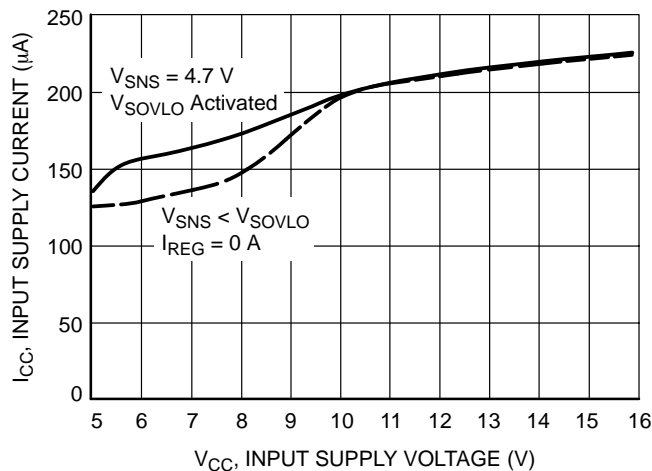

Figure 13. Input Supply Current versus Input Supply Voltage

NCP1800

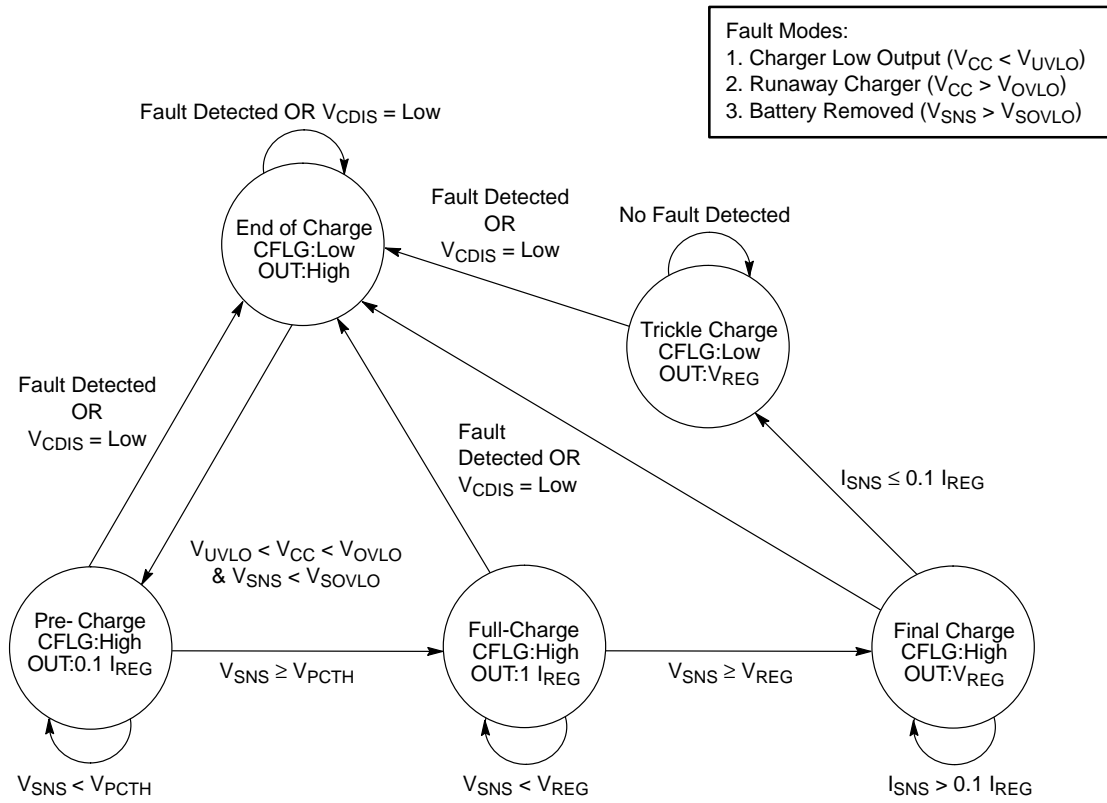

Figure 14. NCP1800 State Machine Diagram

NCP1800

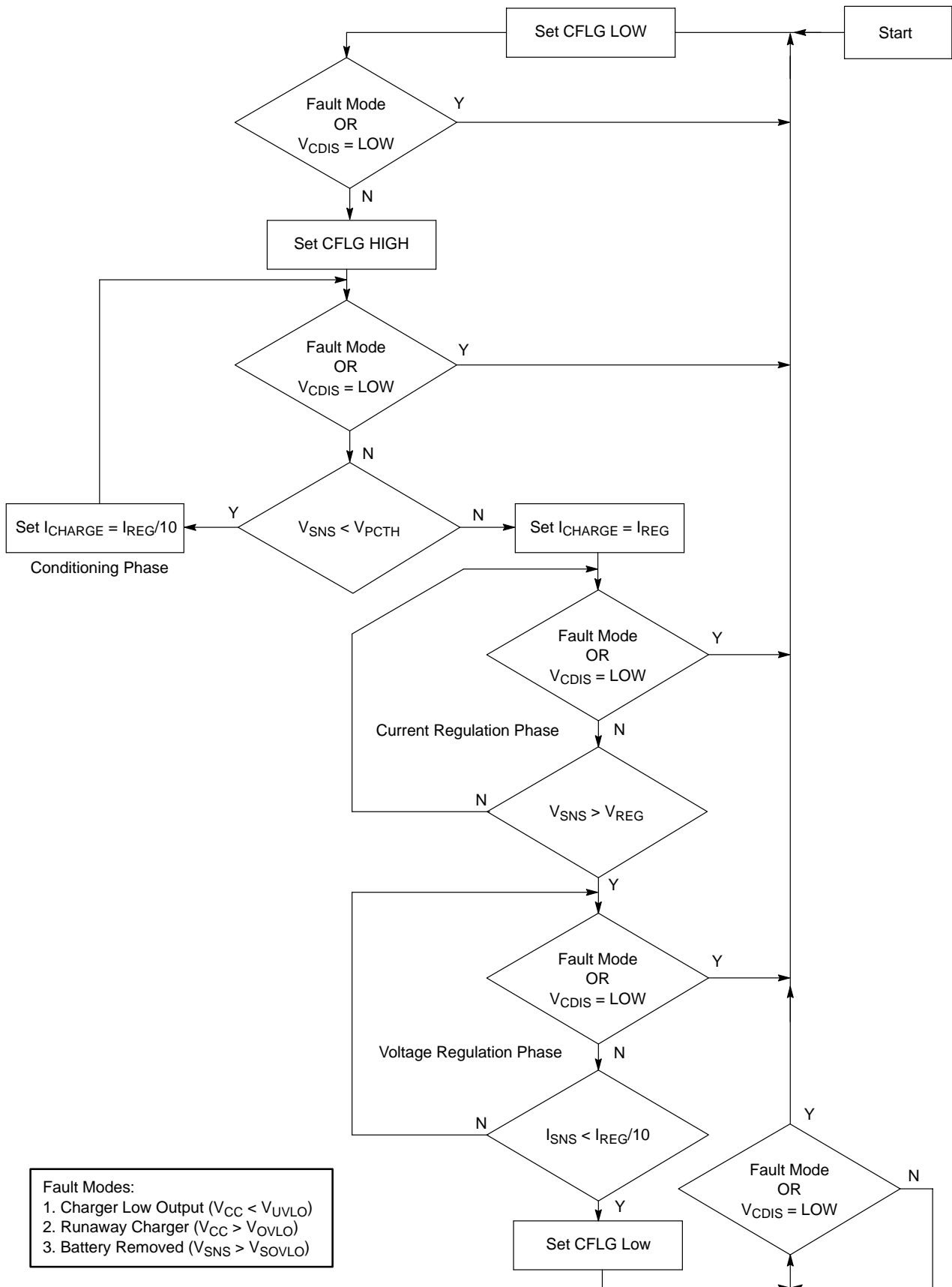

Figure 15. NCP1800 Charging Operational Flow Chart

NCP1800

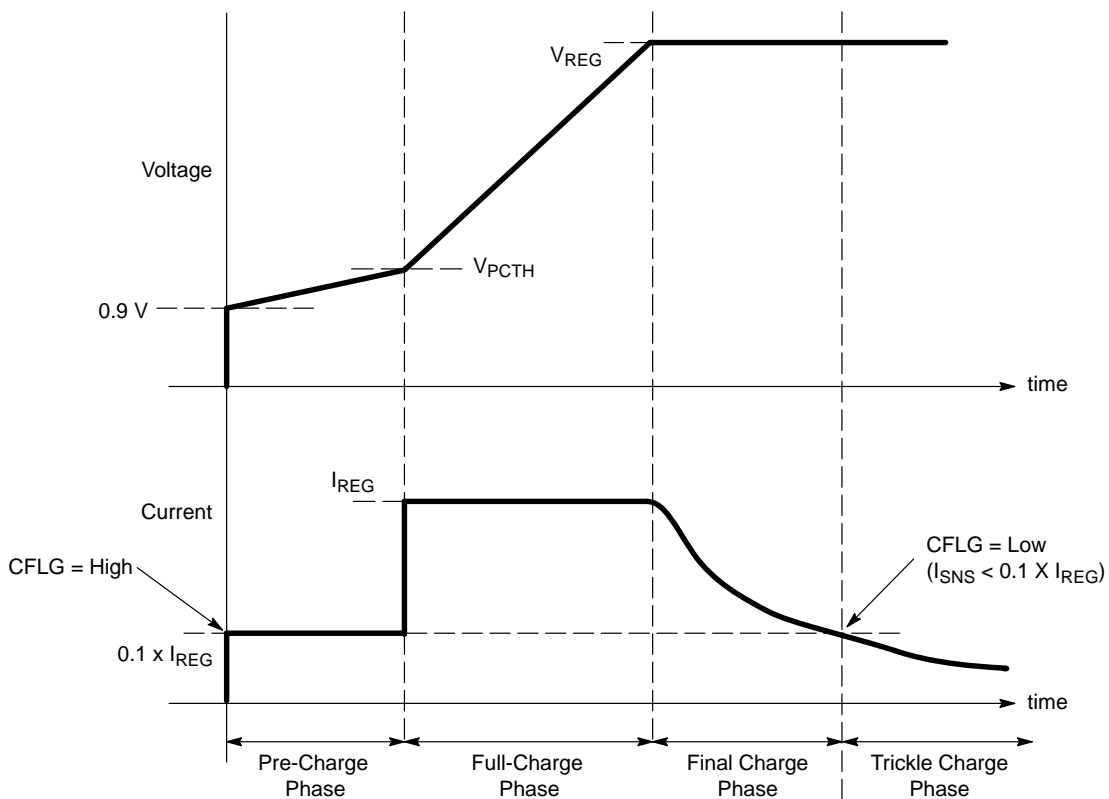

Figure 16. Typical Charging Algorithm

Charge Status

| Conditions | CFLG Pin |
|--|----------|
| Pre-Charge, Full-Charge and Final Charge | High-Z |
| End-of-Charge, Trickle Charge and Faults | Low |

NCP1800

Operation Descriptions

The NCP1800 is a linear lithium ion (Li-ion) battery charge controller and provides the necessary control functions for charging Li-ion batteries precisely and safely. It features the constant current and constant voltage method (CCCV) of charging.

Conditioning and Pre-charge Phase

The NCP1800 initiates a charging cycle upon toggling the COMP/DIS to LOW or application of the valid external power source (i.e. $V_{UVLO} < V_{CC} < V_{OVLO}$) with the Li-ion battery present or when the Li-ion battery is inserted. Before a charge cycle can begin, the battery conditions are verified to be within safe limits. The battery will not be charged when its voltage is less than 0.9 V or higher than V_{SOVLO} .

Li-ion batteries can be easily damaged when fast charged from a completely discharged state. Also, a fully discharged Li-ion battery may indicate an abnormal battery condition. With the built-in safety features of the NCP1800, the Li-ion battery pre-charges (Pre-Charge Phase) at 10% of the full rated charging current (I_{REG}) when the battery voltage is lower than V_{PCTH} and the CFLG pin is HIGH. Typically, the battery voltage reaches V_{PCTH} in a few minutes and then the Full Charge phase begins.

Full Charge (Current Regulation) Phase

When the battery voltage reaches V_{PCTH} , the NCP1800 begins fast charging the battery with full rate charging current I_{REG} . The NCP1800 monitors the charging current at the I_{SNS} input pin by the voltage drop across a current sense resistor, R_{SNS} , and the charging current is maintained at I_{REG} by the pass transistor throughout the full charge phase.

I_{REG} is determined by R_{SNS} and R_{ISEL} with the following formula:

$$I_{REG} = \frac{(1.19 \times 12 \text{ k})}{(R_{ISEL} \times R_{SNS})}$$

And with $R_{ISEL} = 60 \text{ k}$ and $R_{SNS} = 0.4 \Omega$, $I_{REG} = 0.6 \text{ A}$.

Since the external P channel MOSFET is used to regulate the current to charge the battery and operates in linear mode as a linear regulator, power is dissipated in the pass transistor. Designing with a very well regulated external adaptor (e.g. $5.1 \text{ V} \pm 1\%$) can help to minimize the heat dissipation in the pass transistor. Care must be taken in heat sink designing in enclosed environments such as inside the battery operated portables or cellular phones.

The Full Charge phase continues until the battery voltage reaches V_{REG} . The NCP1800 comes in two options with V_{REG} thresholds of 4.1 and 4.2 V.

Final Charge (Voltage Regulation) Phase

Once the battery voltage reaches V_{REG} , the pass transistor is controlled to regulate the voltage across the battery and the Final Charge phase (constant voltage mode) begins. Once the charger is in the Final Charge phase, the charger maintains a regulated voltage and the charging current will begin to decrease and is dependent on the state of the charge of the battery. As the battery approaches a fully charged condition, the charge current falls to a very low value.

Trickle Charge Phase

During the Final Charge phase, the charging current continues to decrease and the NCP1800 monitors the charging current through the current sense resistor R_{SNS} . When the charging current decreases to such a level that $I_{SNS} < 0.1 \times I_{REG}$, the CFLG pin is set to LOW and the Trickle Charge phase begins. The charger stays in the Trickle Charge phase until any fault modes are detected or the COMP/DIS pin is pulled low to start over the charging cycle.

NCP1800

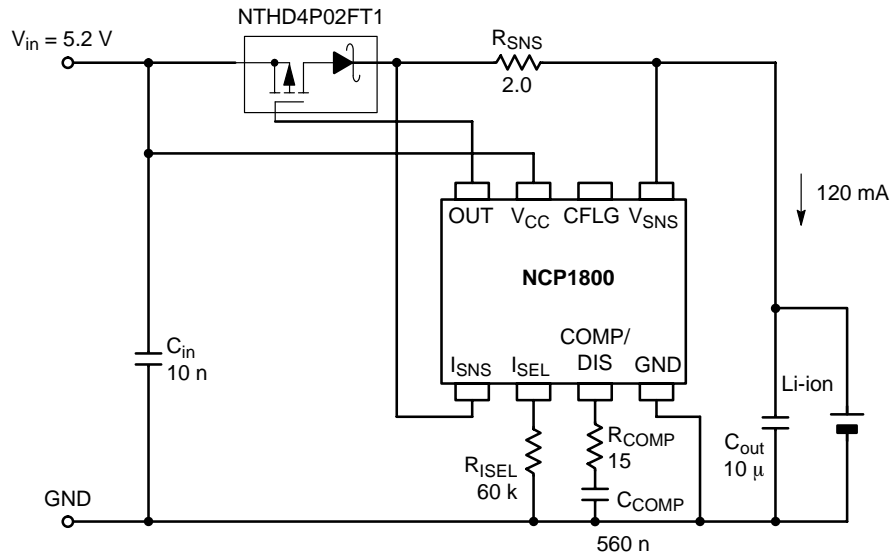

Figure 17. Typical Application Circuit for Lower Capacity Batteries (120 mAh shown here)

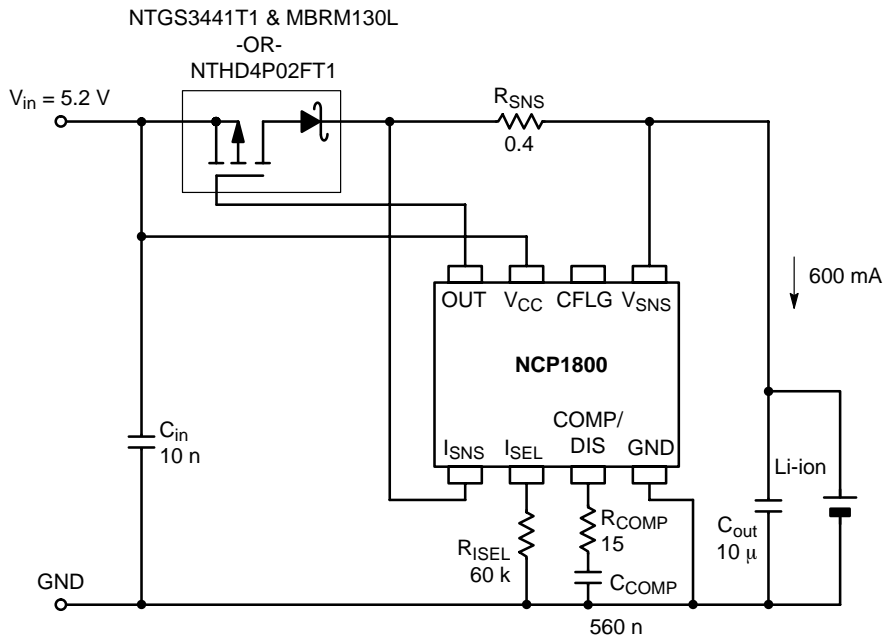

Figure 18. Typical Application Circuit for Higher Capacity Batteries (600 mAh shown here)

NCP1800

Selecting External Components

External Adaptor Power Supply Voltage Selection

Since the NCP1800 is using a linear, charging algorithm, the efficiency is lower. Adaptor voltage selection must be done carefully in order to minimize the heat dissipation. In general, the power supply input voltage should be around 5.0 to 6.0 V. The minimum input voltage should be chosen to minimize the heat dissipation in the system. Excessively high input voltages can cause too much heat dissipation and will complicate the thermal design in applications like cellular phones. With the overvoltage protection feature of the NCP1800, input voltages higher than 7.0 V will activate the overvoltage protection circuit and disconnect the power supply input to the battery and other circuitry.

For the application shown in Figure 18 (assuming NTGS3441 and MBRM130L):

$$\begin{aligned} V_{IN(min)} &> \text{Li-ion regulated voltage,} \\ &V_{REG} + (0.6 \text{ A})(R_{DS(ON)}) \\ &+ V_F \text{ of Schottky Diode} + \text{voltage drop of } R_{SNS} \\ &> 4.2 \text{ V} + (0.6 \text{ A})(100 \text{ m}\Omega) + 0.38 \text{ V} \\ &+ (0.6 \text{ A})(0.4 \Omega) = 4.88 \text{ V} \approx 4.9 \text{ V} \end{aligned}$$

Therefore, for the application shown in Figure 17 (assuming NTHD4P01FT1):

$$\begin{aligned} V_{IN(min)} &> \text{Li-ion regulated voltage} \\ &> 4.2 \text{ V} + (0.12 \text{ A})(130 \text{ m}\Omega) + 0.43 \\ &+ (0.12 \text{ A})(2.0 \Omega) = 4.89 \text{ V} \approx 4.9 \text{ V} \end{aligned}$$

If the output voltage accuracy is 5%, then a typ. 5.2 V \pm 5% output voltage adaptor must be used.

And for a very good regulated adaptor of accuracy 1%, 5.0 V \pm 1% output voltage adaptor can then be used. It is obvious that if tighter tolerance adaptors are used, heat dissipation can be minimized by using lower nominal voltage adaptors.

Pass Element Selection

The type and size of the pass transistor is determined by input-output differential voltage, charging current, current sense resistor and the type of blocking diode used.

The selected pass element must satisfy the following criteria:

Drop across pass element =

$$V_{IN(min)} - \text{Li-ion regulated voltage} - V_F - I_{REG} \times R_{SNS}$$

With:

$$\begin{aligned} V_{IN(min)} &= 5.0 \text{ V} \\ V_{REG} &= 4.2 \text{ V} \\ I_{REG} &= 0.6 \text{ A} \\ R_{SNS} &= 0.4 \Omega \end{aligned}$$

Dropout across pass element =

$$5.0 \text{ V} - 4.2 \text{ V} - 0.38 \text{ V} - (0.6 \text{ A})(0.4 \Omega) = 0.18 \text{ V}$$

Maximum $R_{DS(on)}$ should be less than $(0.18 \text{ V})/(0.6 \text{ A}) = 0.3 \Omega$ at 0.6 A.

$$\begin{aligned} V_{IN(min)} &= 5.0 \text{ V} \\ V_{REG} &= 4.2 \text{ V} \\ I_{REG} &= 0.12 \text{ A} \\ R_{SNS} &= 2.0 \Omega \end{aligned}$$

Dropout across pass element = $5.0 \text{ V} - 4.2 \text{ V} - 0.43 \text{ V} - (0.12)(2.0 \Omega) = 0.13 \text{ V}$.

Therefore, maximum $R_{DS(on)}$ should be less than $(0.13 \text{ V})/(0.12 \text{ A}) = 1.08 \Omega$ at 0.12 A.

External Output Capacitor

Any good quality output filter can be used, independent of the capacitor's minimum ESR. However, a 10 μ F tantalum capacitor or electrolytic capacitor is recommended at the output to suppress fast ramping spikes at the V_{SNS} input and to ensure stability for 1.0 A at full range. The capacitor should be mounted with the shortest possible lead or track length to the V_{SNS} and GND pins.

Current Sense Resistor

The charging current can be set by the value of the current sense resistor as in the previous formula. Proper de-rating is advised when selecting the power dissipation rating of the resistor. If necessary, R_{ISEL} can also be changed for proper selection of the R_{SNS} values. Take note of the recommended full-charge current ranges specified in the electrical characteristics section. Also notice the effect of R_{ISEL} on the accuracy of pre-charge current and end-of-charge detection as noted in Figures 10 and 12, respectively.

NCP1800

PACKAGE DIMENSIONS

Micro8
DM SUFFIX
CASE 846A-02
ISSUE F

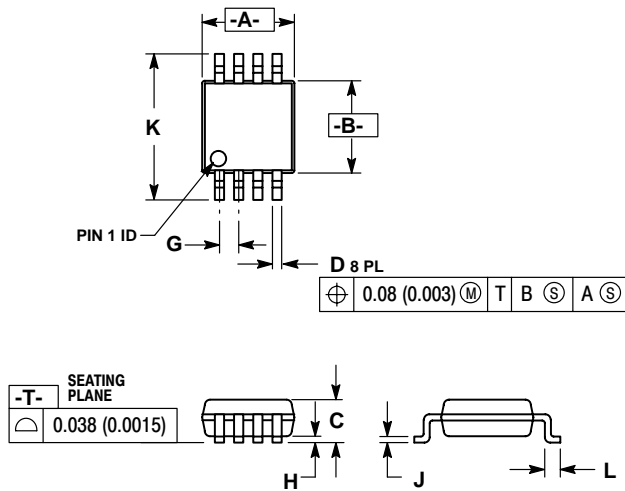

NOTES:

1. DIMENSIONING AND TOLERANCING PER ANSI Y14.5M, 1982.
2. CONTROLLING DIMENSION: MILLIMETER.
3. DIMENSION A DOES NOT INCLUDE MOLD FLASH, PROTRUSIONS OR GATE BURRS. MOLD FLASH, PROTRUSIONS OR GATE BURRS SHALL NOT EXCEED 0.15 (0.006) PER SIDE.
4. DIMENSION B DOES NOT INCLUDE INTERLEAD FLASH OR PROTRUSION. INTERLEAD FLASH OR PROTRUSION SHALL NOT EXCEED 0.25 (0.010) PER SIDE.
5. 846A-01 OBSOLETE, NEW STANDARD 846A-02.

| DIM | MILLIMETERS | | INCHES | |
|-----|-------------|------|-----------|-------|
| | MIN | MAX | MIN | MAX |
| A | 2.90 | 3.10 | 0.114 | 0.122 |
| B | 2.90 | 3.10 | 0.114 | 0.122 |
| C | --- | 1.10 | --- | 0.043 |
| D | 0.25 | 0.40 | 0.010 | 0.016 |
| G | 0.65 BSC | | 0.026 BSC | |
| H | 0.05 | 0.15 | 0.002 | 0.006 |
| J | 0.13 | 0.23 | 0.005 | 0.009 |
| K | 4.75 | 5.05 | 0.187 | 0.199 |
| L | 0.40 | 0.70 | 0.016 | 0.028 |

NCP1800

ChipFET is a trademark of Vishay Siliconix.
FETKY and Micro8 are trademarks of International Rectifier Corporation.

ON Semiconductor and  are registered trademarks of Semiconductor Components Industries, LLC (SCILLC). SCILLC reserves the right to make changes without further notice to any products herein. SCILLC makes no warranty, representation or guarantee regarding the suitability of its products for any particular purpose, nor does SCILLC assume any liability arising out of the application or use of any product or circuit, and specifically disclaims any and all liability, including without limitation special, consequential or incidental damages. "Typical" parameters which may be provided in SCILLC data sheets and/or specifications can and do vary in different applications and actual performance may vary over time. All operating parameters, including "Typicals" must be validated for each customer application by customer's technical experts. SCILLC does not convey any license under its patent rights nor the rights of others. SCILLC products are not designed, intended, or authorized for use as components in systems intended for surgical implant into the body, or other applications intended to support or sustain life, or for any other application in which the failure of the SCILLC product could create a situation where personal injury or death may occur. Should Buyer purchase or use SCILLC products for any such unintended or unauthorized application, Buyer shall indemnify and hold SCILLC and its officers, employees, subsidiaries, affiliates, and distributors harmless against all claims, costs, damages, and expenses, and reasonable attorney fees arising out of, directly or indirectly, any claim of personal injury or death associated with such unintended or unauthorized use, even if such claim alleges that SCILLC was negligent regarding the design or manufacture of the part. SCILLC is an Equal Opportunity/Affirmative Action Employer.

PUBLICATION ORDERING INFORMATION

Literature Fulfillment:

Literature Distribution Center for ON Semiconductor
P.O. Box 5163, Denver, Colorado 80217 USA
Phone: 303-675-2175 or 800-344-3860 Toll Free USA/Canada
Fax: 303-675-2176 or 800-344-3867 Toll Free USA/Canada
Email: ONlit@hibbertco.com

N. American Technical Support: 800-282-9855 Toll Free USA/Canada

JAPAN: ON Semiconductor, Japan Customer Focus Center
2-9-1 Kamimeguro, Meguro-ku, Tokyo, Japan 153-0051
Phone: 81-3-5773-3850

ON Semiconductor Website: <http://onsemi.com>

For additional information, please contact your local
Sales Representative.