

R&E INTERNATIONAL, INC.

4041UB

CMOS QUAD TRUE/COMPLEMENT BUFFER

FEATURES

- ◆ Both True and Complement Outputs Available Simultaneously
- ◆ High Source and Sink Current
- ◆ Diode Protection on All Inputs

DESCRIPTION

The 4041UB Quad True/Complement Buffer is a monolithic integrated circuit constructed with P-Channel and N-Channel enhancement-mode devices. The outputs have low resistance and are capable of sinking or sourcing high currents for use in driver applications where high noise immunity and low power dissipation are required.

This device is useful as a line-driver, CMOS-to-TTL driver, low-power resistor-network driver for A/D and D/A conversion, display and clock drivers.

CONNECTION DIAGRAM (all packages)

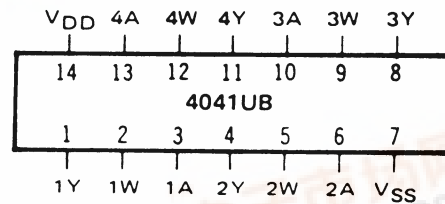

RECOMMENDED OPERATING CONDITIONS

For maximum reliability:

DC Supply Voltage	$V_{DD} - V_{SS}$	3 to 15	Vdc
Operating Temperature	T_A	-55 to +125	°C
		-40 to +85	°C

SCHEMATIC DIAGRAM (one of four buffers)

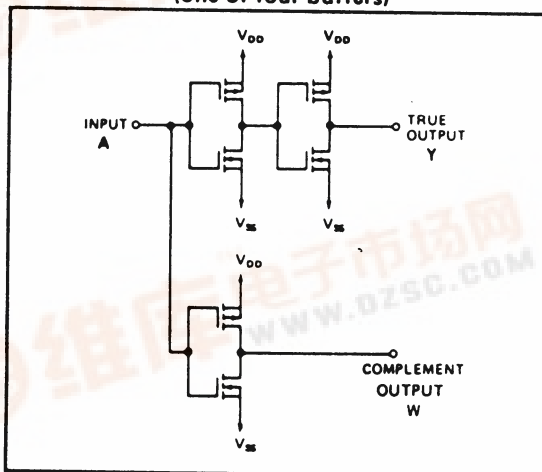

LOGIC DIAGRAM

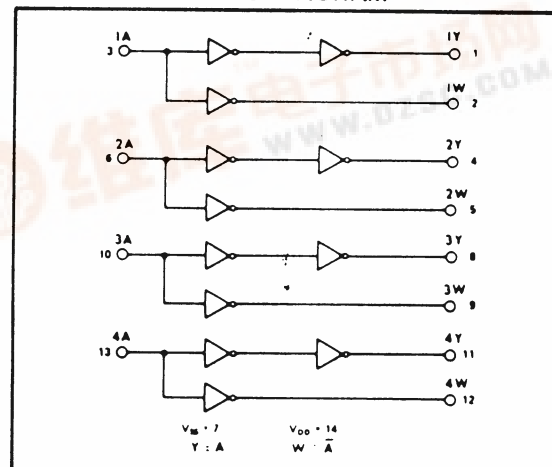

4041UB

ELECTRICAL CHARACTERISTICS

STATIC CHARACTERISTICS¹

PARAMETER	V _{DD} (Vdc)	CONDITIONS	T _{LOW} ²		+25°C			T _{HIGH} ²		Units				
			Min.	Max.	Min.	Typ.	Max.	Min.	Max.					
QUIESCENT DEVICE CURRENT	I _{DD}	5	V _{IN} =V _{SS} or V _{DD}	-	1.0	-	0.005	1.0	-	30	μA _{dc}			
		10	All valid input combinations	-	2.0	-	0.01	2.0	-	60				
		15		-	4.0	-	0.02	4.0	-	120				
MINIMUM INPUT HIGH VOLTAGE	V _{IH}	Non-Inverting Outputs		5	V _{OH} =4.5V	-	3.5	-	2.75	3.5	-	3.5	Vdc	
				10	V _{OH} =9.0V	-	7.0	-	5.5	7.0	-	7.0		
				15	V _{OH} =13.5V	-	11.0	-	8.25	11.0	-	11.0		
		Inverting Outputs		5	V _{OL} =0.5V	-	4.0	-	2.75	4.0	-	4.0		Vdc
				10	V _{OL} =1.0V	-	8.0	-	5.5	8.0	-	8.0		
				15	V _{OL} =1.5V	-	12.0	-	8.25	12.0	-	12.0		
MAXIMUM INPUT LOW VOLTAGE	V _{IL}	Non-Inverting Outputs		5	V _{OL} =0.5V	1.5	-	1.5	2.25	-	1.5	-	Vdc	
				10	V _{OL} =1.0V	3.0	-	3.0	4.5	-	3.0	-		
				15	V _{OL} =1.5V	4.0	-	4.0	6.75	-	4.0	-		
		Inverting Outputs		5	V _{OH} =4.5V	1.0	-	1.0	2.25	-	1.0	-	Vdc	
				10	V _{OH} =9.0V	2.0	-	2.0	4.5	-	2.0	-		
				15	V _{OH} =13.5V	3.0	-	3.0	6.75	-	3.0	-		
OUTPUT HIGH (SOURCE) CURRENT	I _{OH}	Non-Inverting Outputs		5	V _{OH} =4.6V	-1.7	-	-1.4	-2.8	-	-1.0	-	mA _{dc}	
				10	V _{OH} =9.5V	-5.0	-	-4.0	-8.0	-	-2.8	-		
				15	V _{OH} =13.5V	-16	-	-13	-26	-	-9	-		
		Inverting Outputs		5	V _{OH} =4.6V	-0.75	-	-0.6	-1.0	-	-0.42	-	mA _{dc}	
				10	V _{OH} =9.5V	-2.2	-	-1.8	-3.6	-	-1.3	-		
				15	V _{OH} =13.5V	-8.0	-	-6.5	-13	-	-4.5	-		
OUTPUT LOW (SINK) CURRENT	I _{OL}	Non-Inverting Outputs		5	V _{OL} =0.4V	2.0	-	1.6	3.2	-	1.1	-	mA _{dc}	
				10	V _{OL} =0.5V	6.2	-	5.0	10	-	3.5	-		
				15	V _{OL} =1.5V	23	-	18.5	38	-	13	-		
		Inverting Outputs		5	V _{OL} =0.4V	1.0	-	0.8	1.3	-	0.56	-	mA _{dc}	
				10	V _{OL} =0.5V	2.5	-	2.0	4.0	-	1.4	-		
				15	V _{OL} =1.5V	11	-	8.5	17	-	5.8	-		

NOTES: ¹ Remaining Static Electrical Characteristics are listed under "4000B Series Family Specifications".

² T_{LOW} = -55°C for C
= -40°C for E
T_{HIGH} = +125°C for C
= + 85°C for E

ELECTRICAL CHARACTERISTICS (Continued)

DYNAMIC CHARACTERISTICS ($C_L = 50\text{pF}$, $T_A = 25^\circ\text{C}$)

PARAMETER		V_{DD} (Vdc)	Min.	Typ.	Max.	Units
PROPAGATION DELAY TIME Non-Inverting Outputs	t_{PLH}, t_{PHL}	5	—	60	120	ns
		10	—	35	70	
		15	—	25	50	
Inverting Outputs	t_{PLH}, t_{PHL}	5	—	60	120	ns
		10	—	35	70	
		15	—	25	50	
OUTPUT TRANSITION TIME Non-Inverting Outputs	t_{TLH}, t_{THL}	5	—	40	80	ns
		10	—	20	40	
		15	—	15	30	
Inverting Outputs	t_{TLH}, t_{THL}	5	—	35	70	ns
		10	—	20	40	
		15	—	15	30	
INPUT CAPACITANCE	C_{IN}	—	—	10	15	pF

NON-INVERTING (TRUE) OUTPUT

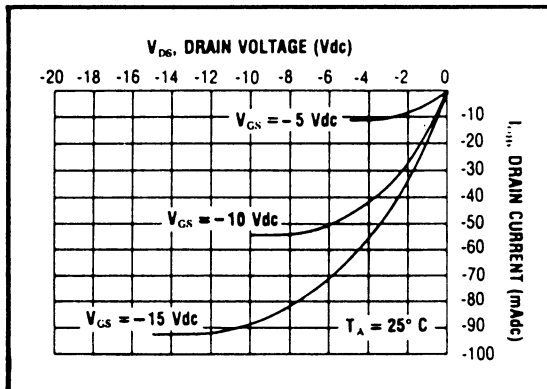

Typical P-Channel
Source Current Characteristics

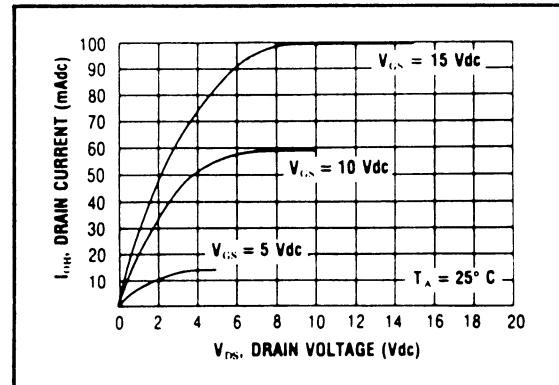

Typical N-Channel
Sink Current Characteristics

INVERTING (COMPLEMENT) OUTPUT

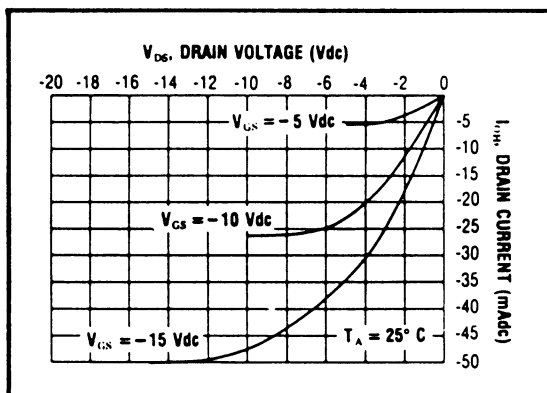

Typical P-Channel
Source Current Characteristics

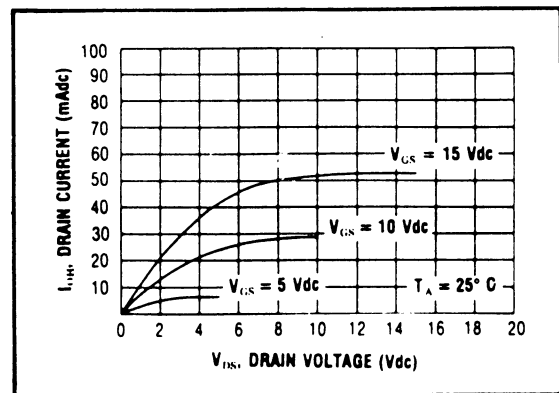

Typical N-Channel
Sink Current Characteristics

4041UB

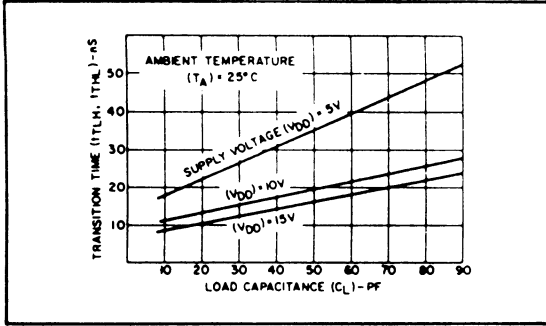

Typical transition time vs. C_L -true output.

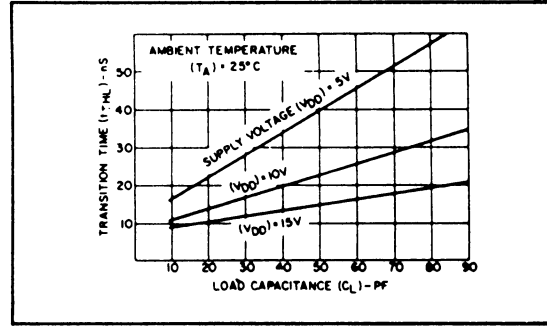

Typical transition time vs. C_L -complement output.

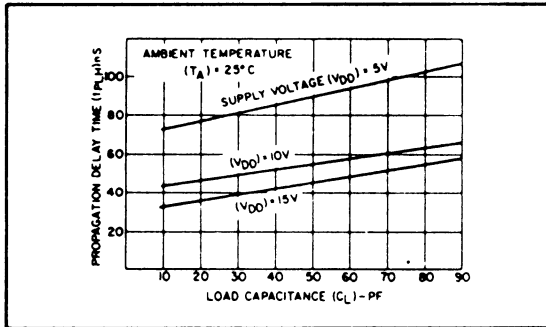

Typical propagation delay time vs. C_L -true output.

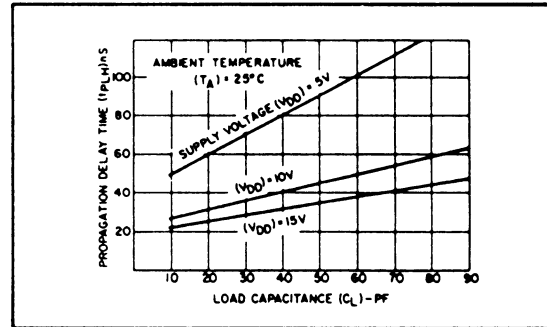

Typical propagation delay time vs. C_L -complement output.

APPLICATIONS INFORMATION

Low Power D/A Converter

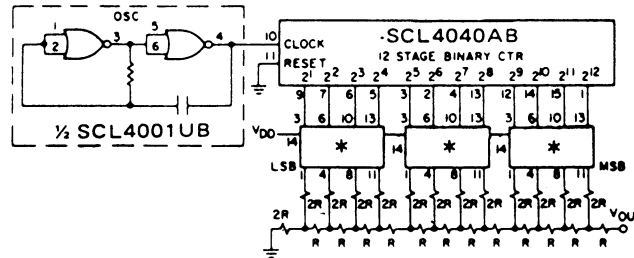

* 4041UB

For resolution and accuracy of $\pm 1/2$ least significant bit (LSB), choose the values for R (shown in Table I) where R equals the value of the external ladder resistor plus the switch source impedance.

The values have been tabulated for $V_{DD} = 5V$ and $V_{SS} = 0V$. For different supply (reference) voltages, the switch source impedance must be computed and added to the value of R shown in Table I).

TABLE I. RESISTANCE VALUES AT $V_{DD}-V_{SS} = 5V$, $T_A = 25^\circ C$

RESOLUTION	ACCURACY OF 1/2 LSB	R_{min} (Ω)
4 bit	$\pm 3.25\%$ of full scale	35 k
6 bit	$\pm 0.8\%$ of full scale	14 k
8 bit	$\pm 0.2\%$ of full scale	56 k
10 bit	$\pm 0.05\%$ of full scale	224 k
12 bit	$\pm 0.0125\%$ of full scale	896 k

TABLE II. ON RESISTANCE VALUES AT $V_{DS} = 0.1V$, $T_A = 25^\circ C$

$V_{DD}-V_{SS}$ (Volts)	R_N (Ω)	R_P (Ω)
5	175 ± 50	200 ± 75
10	75 ± 25	90 ± 30