

# 60 Amp Schottky Rectifier

## SBR6035 — SBR6045

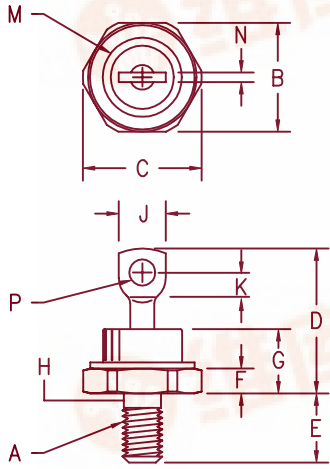

- Notes:
1. Full threads within 2 1/2 threads
  2. Standard Polarity: Stud is Cathode  
Reverse Polarity: Stud is Anode

Dim.	Inches		Millimeter		Notes
	Minimum	Maximum	Minimum	Maximum	
A	---	---	---	---	1/4-28
B	.669	.688	17.00	17.47	
C	---	.794	---	20.16	
D	.750	1.00	19.05	25.40	
E	.422	.453	10.72	11.50	
F	.115	.200	2.93	5.08	
G	---	.450	---	11.43	
H	.220	.249	5.59	6.32	1
J	---	.375	---	9.52	
K	.156	---	3.97	---	
M	---	.510	---	12.95	Dia
N	---	.080	---	2.03	
P	.140	.175	3.56	4.44	Dia

DO-203AB (DO-5)

Microsemi Catalog Number

SBR6035\*  
SBR6040\*  
SBR6045\*

Peak Reverse Voltage

35V  
40V  
45V

\*Add Suffix R For Reverse Polarity

- Schottky Barrier Rectifier
- Low forward voltage
- Guard Ring Protected
- Reverse Energy Tested
- 150°C Junction Temperature
- $V_{RRM}$  -35 to 45 Volts

### Electrical Characteristics

Average forward current per leg	$I_F(AV)$ 60 Amps	$T_C = 102^\circ C$ , Square wave, $R_{\theta JC} = 1.0^\circ C/W$
Maximum surge current per leg	$I_{FSM}$ 1000 Amps	8.3ms, half sine, $T_J = 125^\circ C$
Max repetitive peak reverse current	$I_R(OV)$ 2 Amp	$f = 1$ KHz, $25^\circ C$ , 1 $\mu$ sec Square wave
Max peak forward voltage	$V_{FM}$ .58 Volts	$I_{FM} = 60A: 125^\circ C *$
Max peak reverse voltage	$V_{FM}$ .60 Volts	$I_{FM} = 60A: 25^\circ C *$
Max peak reverse current	$I_{RM}$ 600 mA	$V_{RRM}, T_J = 125^\circ C *$
Max peak reverse current	$I_{RM}$ 2.0 mA	$V_{RRM}, T_J = 25^\circ C$
Typical junction capacitance	$C_J$ 2700 pF	$V_R = 5.0V, T_J = 25^\circ C$

\*Pulse test: Pulse width 300  $\mu$ sec, Duty cycle 2%

### Thermal and Mechanical Characteristics

Storage temp range	$T_{STG}$	-65°C to 175°C
Operating junction temp range	$T_J$	-65°C to 150°C
Max thermal resistance	$R_{\theta JC}$	1.0°C/W Junction to Case
Typical thermal resistance (greased)	$R_{\theta CS}$	0.5°C/W Case to sink
Mounting torque		25-30 inch pounds
Weight		.54 ounces (15.3 grams) typical

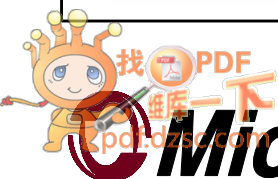

# SBR6035 — SBR6045

Figure 1  
Typical Forward Characteristics

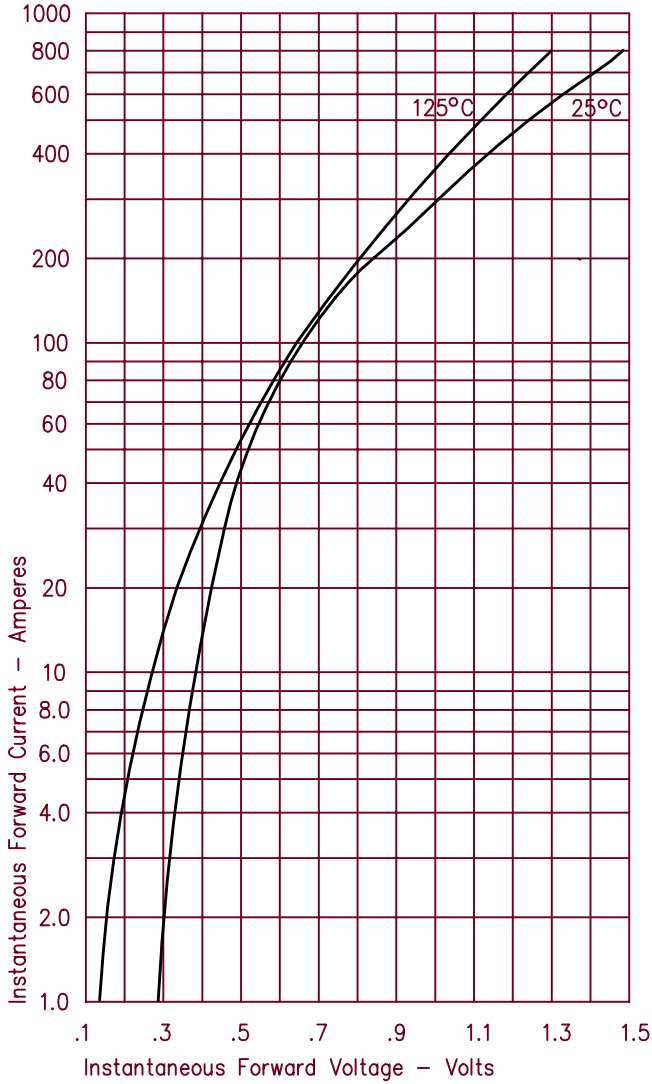

Figure 3  
Typical Junction Capacitance

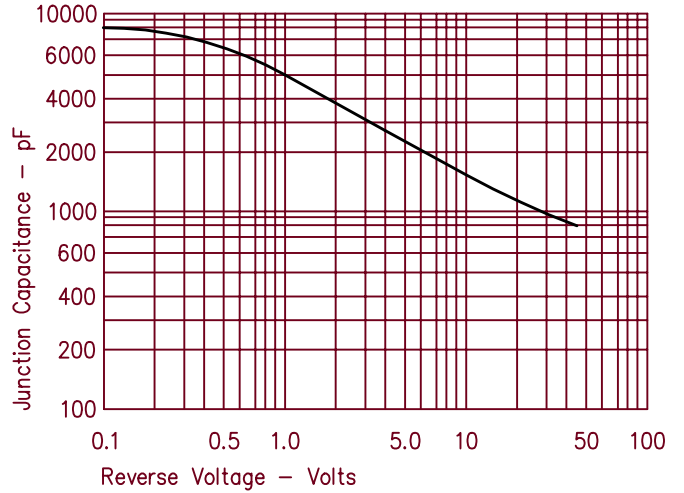

Figure 4  
Forward Current Derating

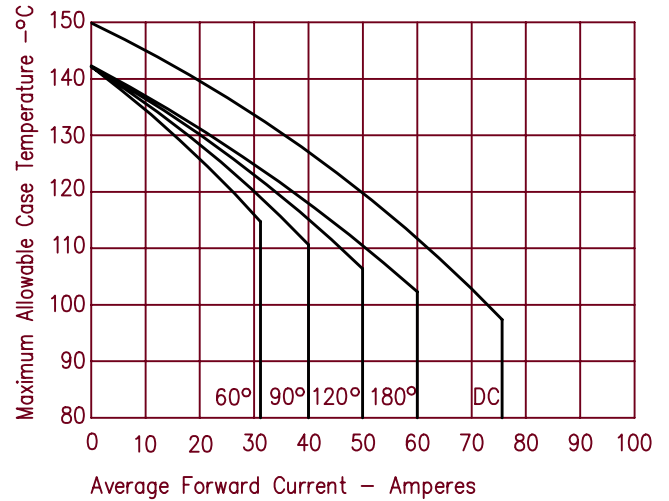

Figure 2  
Typical Reverse Characteristics

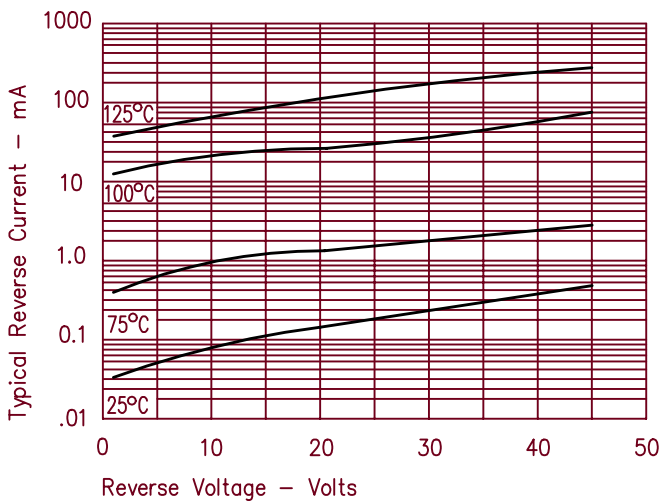

Figure 5  
Maximum Forward Power Dissipation

