



[查询SP2526-1供应商](#)

[捷多邦，专业PCB打样工厂，24小时加](#)

SP2526 [急出货](#)

Evaluation Board Manual

- Easy Evaluation for the **SP2526** USB Compliant Power Control Switch
- **SP2526NEB** contains 2 Independent USB Power Switches with +3.0V to +5.5V Input Range
- Low PC Board Resistance for testing 100mΩ Max On Resistance of **SP2526**
- Evaluation Board complete with all capacitors & ferrite beads to implement a USB Compliant Power Port
- Pin-to-Pin Compatible with Micrel MIC2526

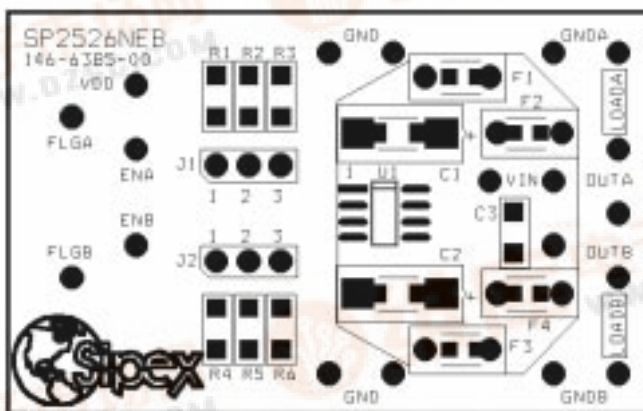

DESCRIPTION

The **SP2526 Evaluation Board** is designed to help the user evaluate the performance of the **SP2526** for use as a dual +3.0V to +5.5V USB Supervisory Control Switch. Each channel of the **SP2526** can be evaluated for its low on-resistance and capacity to supply 500mA output current. The **SP2526 Evaluation Board** is designed with independent V_{DD} and V_{IN} connections to make it easy to measure the very low quiescent current of 100μA maximum, and low PC board resistance for evaluating the very low on-resistance of 100mΩ maximum.

The evaluation board is a completely assembled and tested surface mount board which provides easy probe access points to all **SP2526** Inputs and Outputs so that the user can quickly connect and measure electrical characteristics and waveforms.



SP2526 EVALUATION BOARD

The next two sections describe the **SP2526** Board Layout and Using the **SP2526 Evaluation Boards**. A table of **SP2526** Pin Assignments is also included with details on Input/Output pin function. A **SP2526 Evaluation Board** List of Materials table is provided with some manufacturers part numbers to use as a reference. Finally, a schematic and drawings of the PC Board Layout are included of the **SP2526 Evaluation Board**.

BOARD LAYOUT

The **SP2526 Evaluation Board** has been designed to easily and conveniently provide access to all Inputs and Outputs of the **SP2526** device under test. Position the board with the silkscreen lettering upright (see *Figure 1* Component Layout) and you will see the **SP2526** SOIC labeled U1 in the center right of the board, and around it the Capacitors C1,2,3 and Ferrite Beads F1-4 forming the Dual USB Supervisory Switch.

The **SP2526 Evaluation Board** provides solder pads to connect wires to an external power supply and load, as well as Test Point Posts to monitor the Input and Output Voltages at these connections to the **SP2526**. The **SP2526** PC Board Layout has been designed with low resistance input and output connections of $2\text{m}\Omega$ each to provide the lowest On-Resistance for utilizing the USB Switch.

The PC Layout is given in Figures 1-3 for the user as an aid in designing a low resistance USB switch on a PC board. The PC board used has 1oz Copper with V_{IN} , Ground, V_{OUT} traces of at least 0.1inch width for $5\text{m}\Omega/\text{inch}$ or looked at another way as $0.5\text{m}\Omega/\text{square}$. This means to maintain a trace resistance of only $2\text{m}\Omega$, you need to have only 4 squares of trace from one end to another. Resistance is further reduced by some additional wide V_{IN} , Ground and V_{OUT} connections on the bottom side of the PC board which are connected to the top side with large through-hole connections. For best results with on-resistance in the ferrites used for EMI suppression in the Output and Ground connections, through-hole ferrite beads were used for F1-4, yielding $2\text{m}\Omega$

per input or output connection versus using surface-mount size 0805 ferrite beads which yielded $5\text{m}\Omega$ per input or output connection.

USING THE EVALUATION BOARD

The **SP2526 Evaluation Board** can be connected to a power supply using a pair of wires soldered to the solder pads marked provided “VIN” and “GND”. It is good practice to not switch power on until power connections are made to the evaluation board.

Powering Up & Using the SP2526 Circuit

V_{IN} — U1-7 — Solder wire to VIN solder pad on component side of board and connect to external Power Supply positive. $V_{\text{IN}} = +3.0\text{V}$ to $+5.5\text{V}$. Connect Voltmeter positive or Oscilloscope probe to V_{IN} test point post to monitor actual voltage input to PC board.

GND — U1-6 — Solder wire to GND solder pad on component side of board and connect to external Power Supply negative. Connect Voltmeter negative or Oscilloscope probe ground to GND test point post to monitor actual voltage input to PC board.

OUTA — U1-8 — Solder wire to OUTA solder pad on component side of board and connect to external load. Connect Voltmeter positive or Oscilloscope probe to OUTA test point post to monitor actual voltage output at the PC board.

GNDA — Solder wire to GNDA solder pad on component side of board and connect to external LoadA return. Connect Voltmeter negative or Oscilloscope probe ground to GND test point post to monitor actual voltage input to PC board.

OUTB — U1-5 — Solder wire to OUTB solder pad on component side of board and connect to external load. Connect Voltmeter positive or Oscilloscope probe to OUTB test point post to monitor actual voltage output at the PC board.

GNDB — Solder wire to GNDB solder pad on component side of board and connect to external LoadB return. Connect Voltmeter negative or Oscilloscope probe ground to GND test point post to monitor actual voltage input to PC board.

V_{DD} — Connect to a second Power Supply 5V (or 3.3V) connection – V_{DD} provides the pull-up voltage for Enables ENA & ENB and Flags FLGA & FLGB. This separate supply connection allows the user to separately measure V_{IN} supply current.

GND — Second Power Supply GND Connection – connect to supply return for V_{DD} .

ENA — U1-1 — Enable A Input must be connected High or Low – open produces unstable behavior, so be sure to connect V_{DD} to an external 3.3V or 5V source. See *Table 1* Enable Jumpers for information on Enable Jumper J1 position. The user can actively control Switch A with an external Logic signal.

FLGA — U1-2 — Flag A output is open drain and has a pull-up to V_{DD} (which should be connected to an external source). Connect FLGA to voltmeter or oscilloscope to monitor Switch A for flags when Low if Under-voltage, Over-current or Over-temperature occurs.

ENB — U1-4 — Enable B Input must be connected High or Low – open produces unstable behavior, so be sure to connect V_{DD} to an external 3.3V or 5V source. See *Table 1* Enable Jumpers for information on Enable Jumper J2 position. The user can actively control Switch B with an external Logic signal.

FLGB — U1-3 — Flag B output is open drain and has a pull-up to V_{DD} (which should be connected to an external source). Connect FLGB to voltmeter or oscilloscope to monitor Switch B for flags when Low if Under-voltage, Over-current or Over-temperature occurs.

Using the Enable Jumpers J1 & J2

The jumpers J1 & J2 have 2 positions, as described below. Connecting a logic level to the ENA or ENB test point post will override the pull-up or pull-down to actively control the switch.

| Part Number | Enable | Enable A J1 Position | Enable B J2 Position |
|-------------|-------------|----------------------|----------------------|
| SP2526-1 | Active High | 1-2 Pull-up | 1-2 Pull-up |
| SP2526-2 | Active Low | 2-3 Pull-down | 2-3 Pull-down |

Table 1. Enable Jumpers J1 & J2

Table 2. SP2526EB PIN ASSIGNMENTS

| SP2526EB Pin Assignments | | | |
|---------------------------------|-----------------|--------------------------------|------------------------------|
| Pin # | Pin Name | Pin Function | Input/Output Pin Name |
| SP2526-1 | | | |
| 1 | ENA | Enable A Input Active High | ENA |
| 2 | FLGA | Fault Flag A Output Active Low | FLGA |
| 3 | FLGB | Fault Flag B Output Active Low | FLGB |
| 4 | ENB | Enable B Input Active High | ENB |
| 5 | OUTB | Switch B Output | OUTB |
| 6 | GND | Ground | GND |
| 7 | IN | Supply Input | V _{IN} |
| 8 | OUTA | Switch A Output | OUTA |
| SP2525-2 | | | |
| 1 | ENA | Enable A Input Active Low | ENA |
| 2 | FLGA | Fault Flag A Output Active Low | FLGA |
| 3 | FLGB | Fault Flag B Output Active Low | FLGB |
| 4 | ENB | Enable B Input Active Low | ENB |
| 5 | OUTB | Switch B Output | OUTB |
| 6 | GND | Ground | GND |
| 7 | IN | Supply Input | V _{IN} |
| 8 | OUTA | Switch A Output | OUTA |

Table 3. SP2526EB LIST OF MATERIALS

| SP2526 Evaluation Board List of Materials | | | | | | | |
|---|------|-----------|--------------------|----------------------|-------------|-----------------------|---------------------|
| Ref. Des. | Qty. | Manuf. | Manuf. Part Number | Digi-Key Part Number | Layout Size | Component | Vendor Phone Number |
| PCB | 1 | Sipex | 146-6385-00 | - | 1.2"x1.9" | SP2526 Eval PCB | 978-667-7800 |
| U1 | 1 | Sipex | SP2526XCN | - | SO-8 | Dual USB Switch | |
| C1,2 | 2 | Kemet | T495D157K010AS | - | "D" SM | 6.3V 150uF Low ESR | 864-963-6300 |
| C3 | 1 | Panasonic | ECJ-VB1E104K | PCC1883CT-ND | 1206 SM | X7R 0.1uF 25V | Digi-Key |
| F1-4 | 4 | Panasonic | EXC-ELDR25C | P9819BK-ND | 7.5X2.2mm | EMI Bead | 800-344-4539 |
| F1-4 | 4 | Panasonic | EXC-ELDR35C | P9817BK-ND | 9X2.2mm | EMI Bead | Digi-Key |
| F1-4 | 4 | Panasonic | EXC-L351350 | P9823-ND | 5X3.5mm | EMI Bead | Digi-Key |
| F1-4 | 4 | Panasonic | EXC-ML20A390U | P10191CT-ND | 0805 SM | SM EMI Bead | Digi-Key |
| R1-6 | 6 | Panasonic | ERJ-8GEYJ104 | P100KECT-ND | 1206 SM | 100K ohm 1/8W 5% | Digi-Key |
| TP | 12 | Mill-Max | 3137-3002-10-0080 | ED5009-ND | .042 Dia | Test Point Female Pin | Digi-Key |
| J1,2 | 2 | Sullins | PZC36SAAN | S1011-36-ND | .32x.12 | 36-Pin (3x12) Header | Digi-Key |
| | 2 | Sullins | STC02SYAN | S9000-ND | .2x.1 | Shunt | Digi-Key |

SP2526 Evaluation Board Schematic

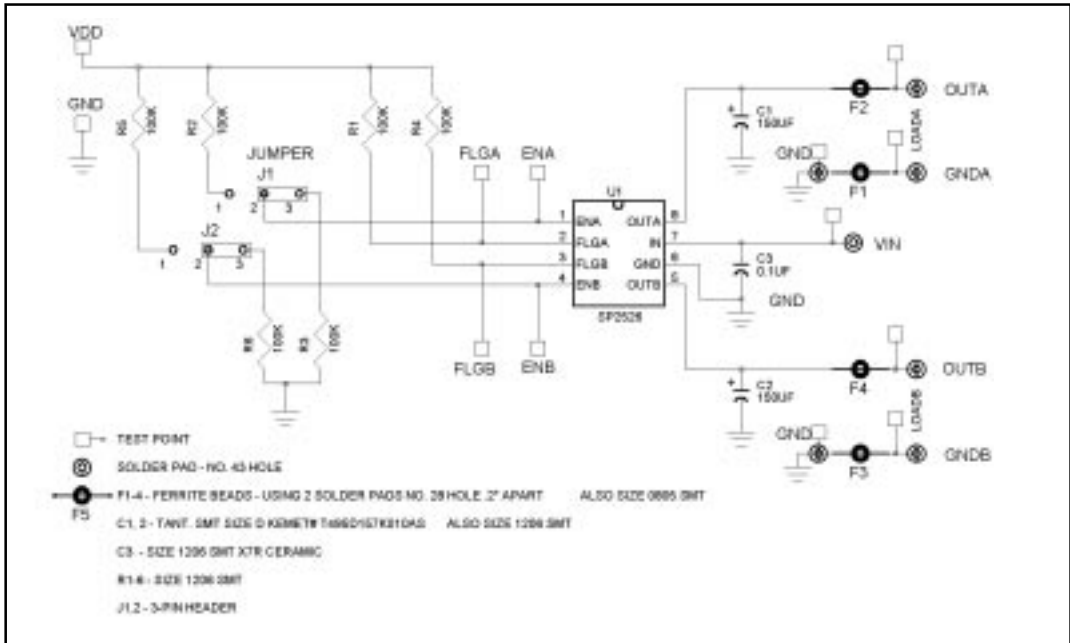

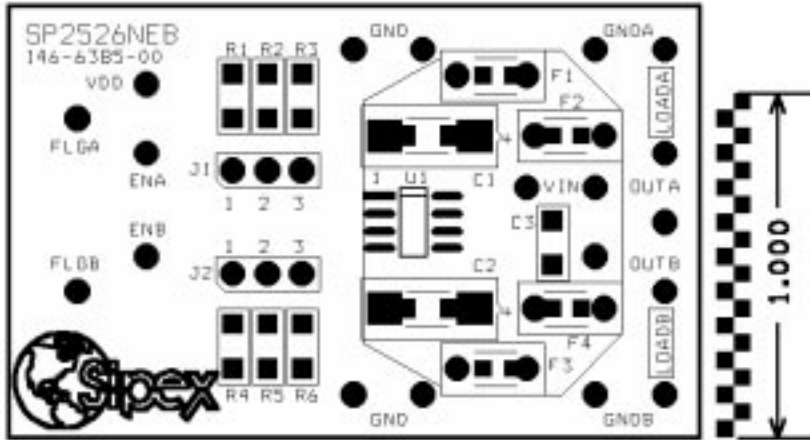

Figure 1. SP2526NEB Component Placement

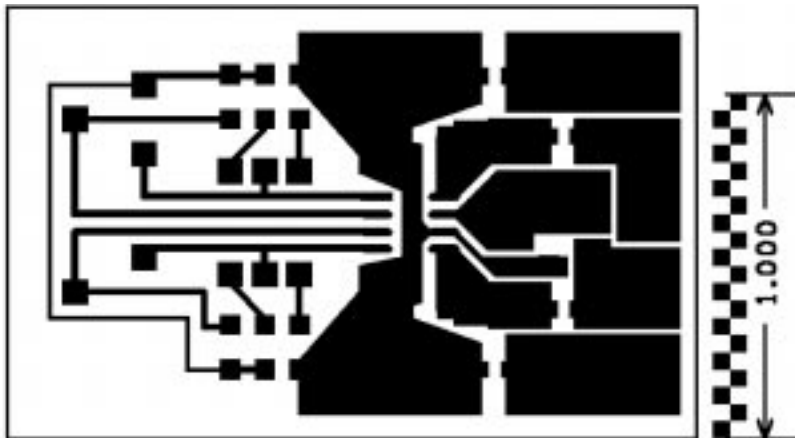

Figure 2. SP2526NEB PC Layout Component Side

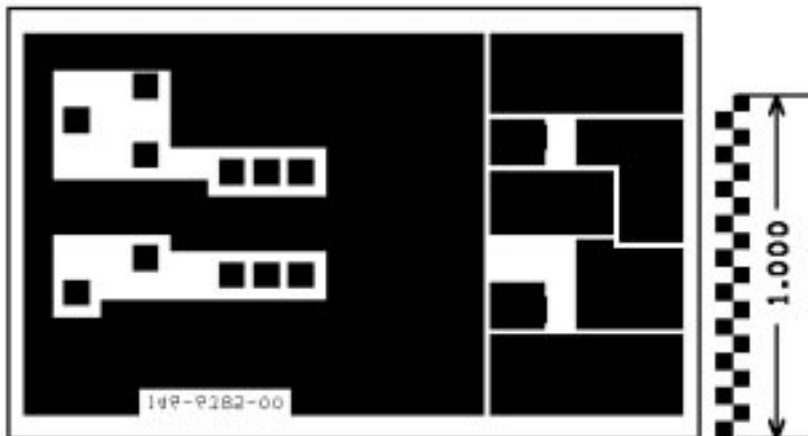

Figure 3. SP2526NEB PC Layout Soldier Side

ORDERING INFORMATION

Model

SP2526-1NEB SP2526EN-1 Evaluation Board
SP2526-2NEB SP2526EN-2 Evaluation Board

Package

SIGNAL PROCESSING EXCELLENCE

Sipex Corporation**Headquarters and Sales Office**

22 Linnell Circle
Billerica, MA 01821
TEL: (978) 667-8700
FAX: (978) 670-9001
e-mail: sales@sipex.com

Sales Office

233 South Hillview Drive
Milpitas, CA 95035
TEL: (408) 934-7500
FAX: (408) 935-7600

European Sales Offices:**GERMANY:**

Sipex GmbH
Gautinger Strasse 10
82319 Starnberg
TEL: 49.81.51.89810
FAX: 49.81.51.29598
e-mail: sipex-starnberg@t-online.de

Far East:**JAPAN:**

Nippon Sipex Corporation
Yahagi No. 2 Building
3-5-3 Uchikanda, Chiyoda-ku
Tokyo 101, Japan
TEL: 011.81.3.3256.0577
FAX: 011.81.3.3256.0621